

September 30, 2022

Version 3

Safety Recall: 2019–20 Civic Fuel Pump MotorSupersedes 21-029, dated July 30, 2021, to revise the information highlighted in **yellow**.**AFFECTED VEHICLES**

Year	Model	Trim Level	VIN Range
2019	Civic 2-Door	All except Si (HCM, HMIN)	Check the iN VIN status for eligibility.
2019	Civic 4-Door	All except Si (HCM, HMIN)	Check the iN VIN status for eligibility.
2019-20	Civic 5-Door	All except Type R (HUM)	Check the iN VIN status for eligibility.

REVISION SUMMARYUnder **REPAIR PROCEDURE**, step 46 was revised.**BACKGROUND**

Due to swelling of the fuel pump motor impeller, the fuel pump may seize and stop working. If this occurs, the check engine light may be displayed with DTC P0087 (Fuel Rail Pressure Too Low) stored, the engine may not start, or the engine could stall while driving, increasing the risk of a crash.

CUSTOMER NOTIFICATION

Owners of affected vehicles will be sent a notification of this campaign.

Do an iN VIN status inquiry to make sure the vehicle is shown as eligible.

Some vehicles affected by this campaign may be in your new or used vehicle inventory.

Failure to repair a vehicle subject to a recall or campaign may subject your dealership to claims or lawsuits from the customer or anyone else harmed as a result of such failure. To see if a vehicle in inventory is affected by this safety recall, do a VIN status inquiry before selling it.

CORRECTIVE ACTION

Replace the fuel pump motor.

NOTE: If the vehicle has any of the symptoms listed in **BACKGROUND**, you must apply this bulletin before attempting any other repairs. If the symptoms remain after the recall repair is complete, only attempt further repairs (such as replacing the high pressure fuel pump) after authorized troubleshooting.

CUSTOMER INFORMATION: The information in this bulletin is intended for use only by skilled technicians who have the proper tools, equipment, and training to correctly and safely maintain your vehicle. These procedures should not be attempted by “do-it-yourselfers,” and you should not assume this bulletin applies to your vehicle, or that your vehicle has the condition described. To determine whether this information applies, contact an authorized Honda automobile dealer.

PARTS INFORMATION

NOTE: Due to limited supply, this is a controlled part and will require a valid VIN when ordering.

Part Name	Part Number	Quantity
Fuel Pump Motor Kit	06170-TBA-306	1

For dealers experiencing a strong fuel smell from storing a fuel pump motor replaced under this service bulletin, the fuel pump motor may be disposed of immediately in accordance with local regulations. This only applies to the fuel pump motor replaced under this service bulletin. The published retention policy remains in effect for all other parts.

If you have any questions about this exception or other parts retention issues, contact the WPI Administrative Office at **937-642-2737**.

TOOL INFORMATION

Tool Name	Part Number	Quantity
Fuel Sender Wrench	07AAA-TBAA100	1
ORVR Service Plug	07AAK-TBAA100	1

WARRANTY CLAIM INFORMATION

Operation Number	Description	Flat Rate Time	Defect Code	Symptom Code	Template ID	Failed Part Number
3101HK	2- and 4-door - Replace the fuel pump motor, and do the VSA sensor neutral position memorization procedure.	1.3 hr	6FE00	AAE00	A21029A	17045-TBA-A00
	5-door - Replace the fuel pump motor, and do the VSA sensor neutral position memorization procedure.	1.4 hr			A21029B	

Skill Level: Repair Technician

REPAIR PROCEDURE

⚠ WARNING

Fuel pump motor removal exposes fuel, which can ignite, causing a fire or explosion.

This can cause serious injury or death.

Always work in a well-ventilated area and keep sparks or open flames away.

1. Insert the emergency fuel fill funnel into the fuel filler neck to relieve the pressure in the fuel tank.

NOTE: The emergency fuel fill funnel is in the trunk tool box.

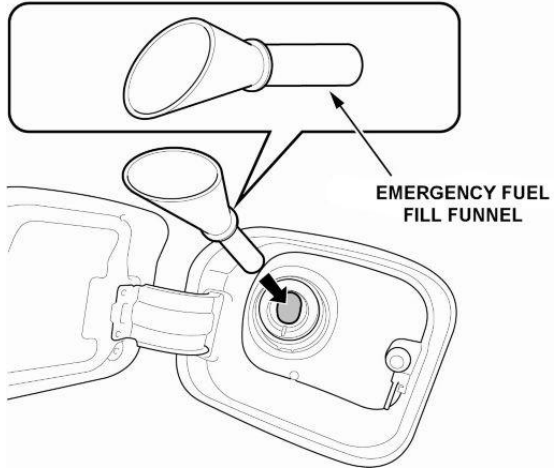

2. Remove the PGM-FI main relay 2.

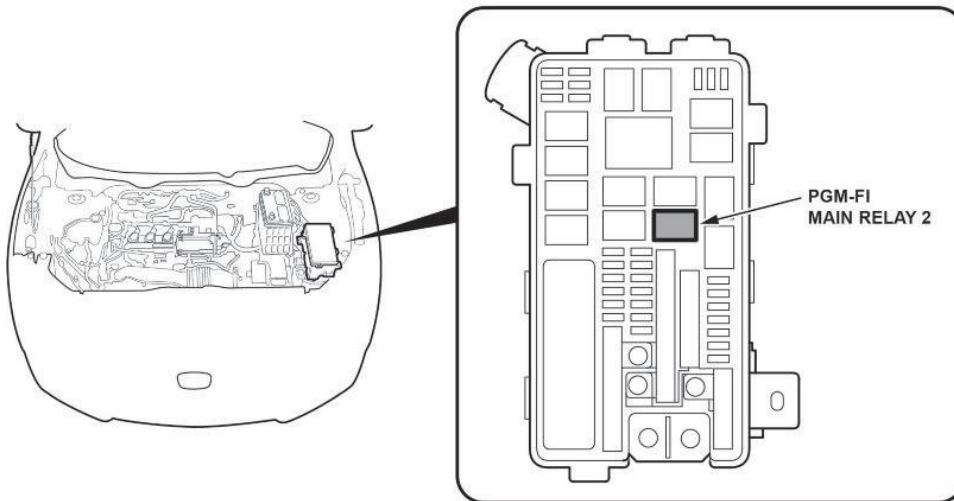

3. Start the engine, and let it idle until it stalls.
4. Turn the ignition to OFF.
5. Install the PGM-FI main relay 2.

6. Disconnect both 12-volt battery terminals.

NOTICE

To protect the terminal connector from damage, do not hold it when removing the negative terminal.

NOTE:

- Always disconnect the negative terminal first.
- Do not disconnect the 12-volt battery sensor from the cable.

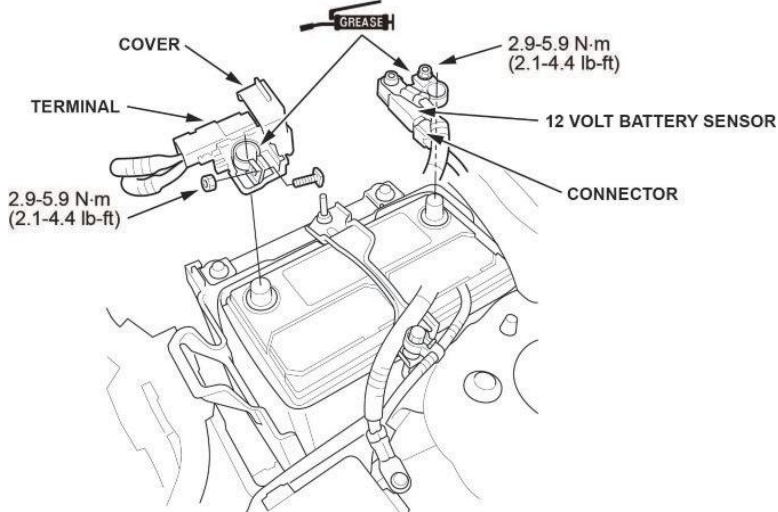

7. Remove the rear seat cushion bolt.

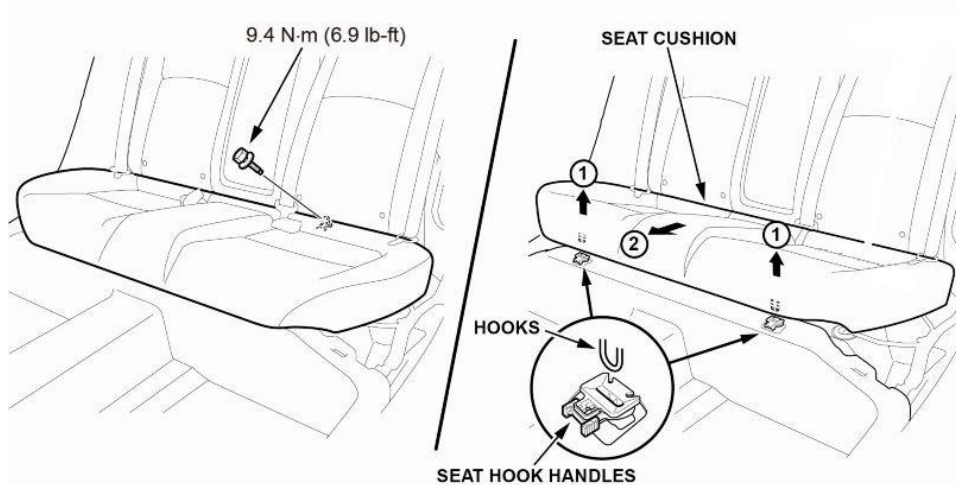

8. While pushing down on the seat cushion, pull the seat hook handles to release the hooks.

9. Remove the rear seat cushion.

10. *5-door models*: Remove both tie down hooks, then release the two clips by pulling up on the front edge of the cargo floor cover.

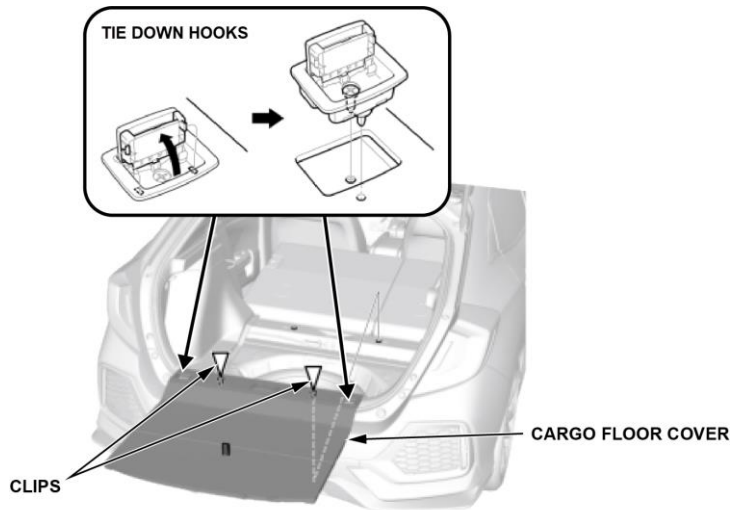

11. Fold down the right-rear seat-back.

12. Turn over the bottom of the right-rear seat-back cover, then remove the bolts.

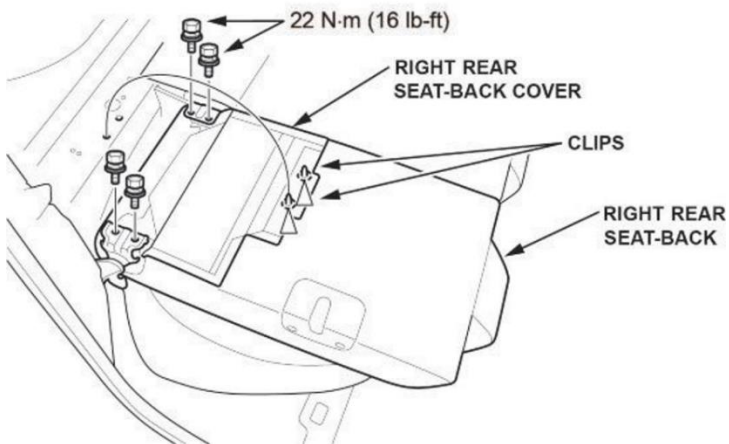

13. Remove the right-rear seat-back.

14. Fold down the left-rear seat-back.

15. Turn over the bottom of the left-rear seat-back cover, then remove the bolts.

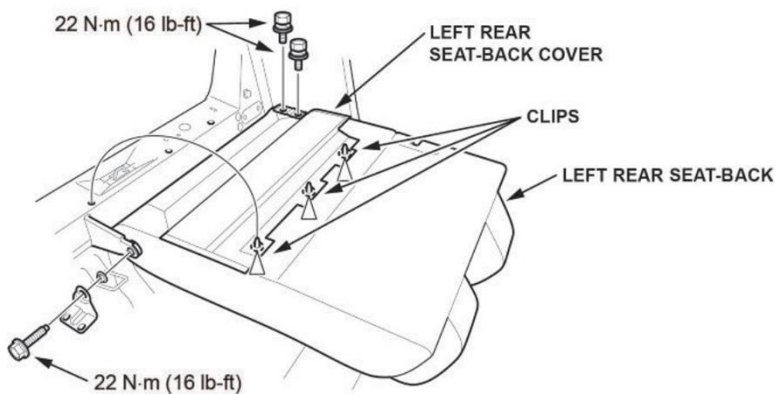

16. Remove the left rear seat-back.
17. Remove the center rear seat belt lower anchor bolt.

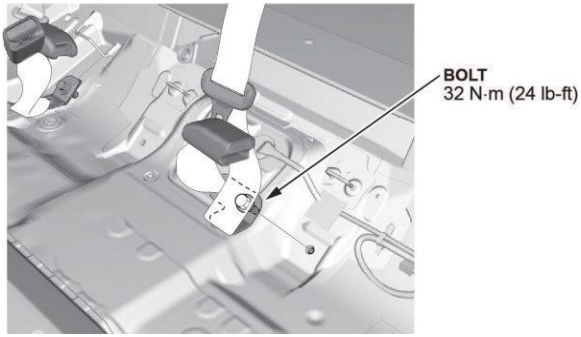

18. Remove the fuel tank unit access panel, and disconnect the connector.

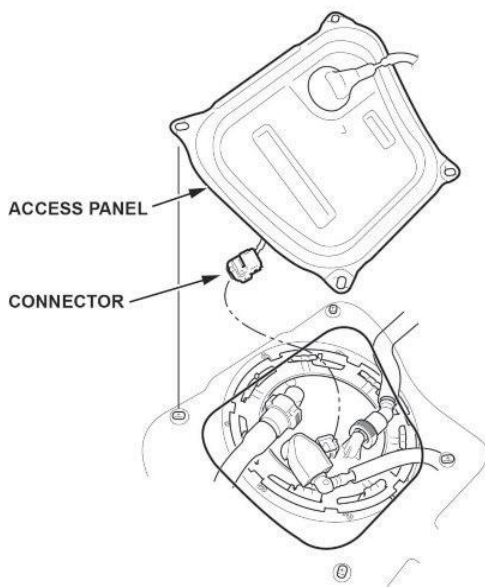

19. Lift the front of the vehicle.

NOTICE

If the fuel level is showing **90%** or more, the front of the vehicle must be raised more than **345 mm (13.58 in)** as shown to prevent fuel spillage when the fuel tank unit is removed. Make sure the vehicle is securely supported when raised.

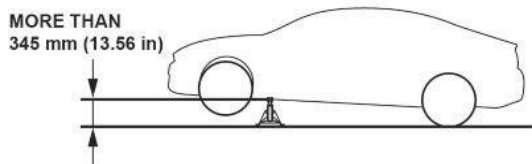

20. Disconnect the quick-connect fitting from the fuel tank unit.

NOTE: Remove the fuel connector cover if necessary.

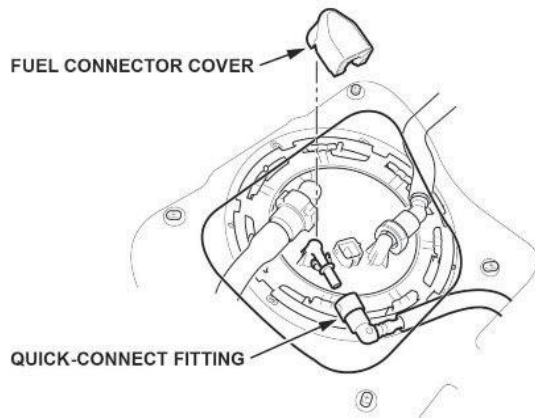

21. Unlock the fuel tank unit cam lock ring using the fuel sender wrench (T/N 07AAA-TBAA100).

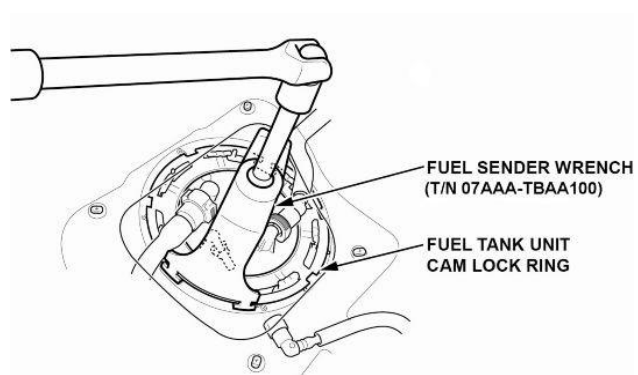

22. Set the fuel sender wrench as shown, and make sure it does not float while turning.

23. Turn the fuel tank unit cam lock ring counterclockwise.

24. Disconnect the fuel vent tube and fuel tank vapor recirculation tube.

NOTE:

- Do not bend the fuel vent tube and fuel tank vapor recirculation tube excessively. After disconnecting both tubes, rotate the fuel tank unit clockwise to fully remove them.
- Do not forcibly remove the fuel vent tube and fuel tank vapor recirculation tube. The tubes are fragile; be careful when removing them.

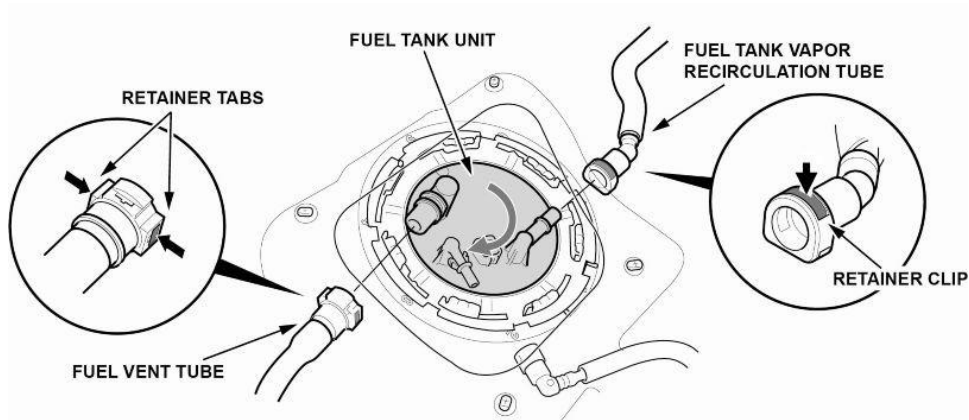

25. Hold the fuel vent tube with one hand, push the retainer tabs in **all the way** with the other hand, then disconnect the tube.

26. Push in the fuel tank vapor recirculation tube toward the fuel tank unit, push down on the retainer clip, then disconnect the tube.

27. Pull the tubes off by slightly rotating the fuel tank unit clockwise.

28. Remove the fuel tank unit cam lock ring.

NOTE: After unlocking the fuel tank unit cam lock ring, clean the top of the fuel pump flange and adjacent areas to make sure it's free of dirt, dust, and debris.

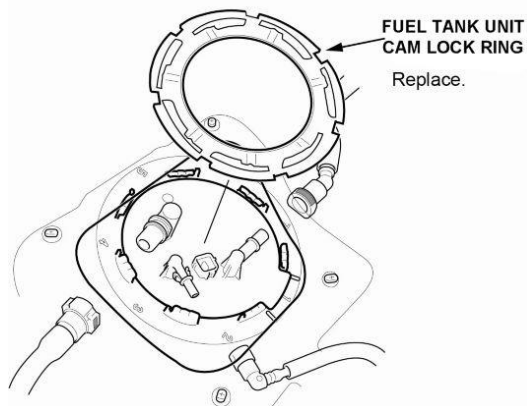

29. Partially remove the fuel tank unit.

30. Hook the clip end of the ORVR service plug (T/N 07AAK-TBAA100) lanyard on to the child safety seat hook as shown. Then, place the ORVR service plug near the fuel tank unit opening.

NOTE:

- The fuel pump motor kit includes a ORVR plug without the lanyard. It can be used in place of the ORVR service plug (T/N 07AAK-TBAA100), but only use it if ORVR service plug (T/N 07AAK-TBAA100) is unavailable or damaged. If using the ORVR plug without the lanyard, tie a wire to it so it can be tied to the child safety seat hook.
- Avoid damaging any part of the ORVR service plug's surface. Damage to the service plug may cause fuel leaks into the inner fuel vent tube. Use the provided protective cap when the ORVR service plug is not in use. If there is damage, throw away the ORVR service plug and order a new one.

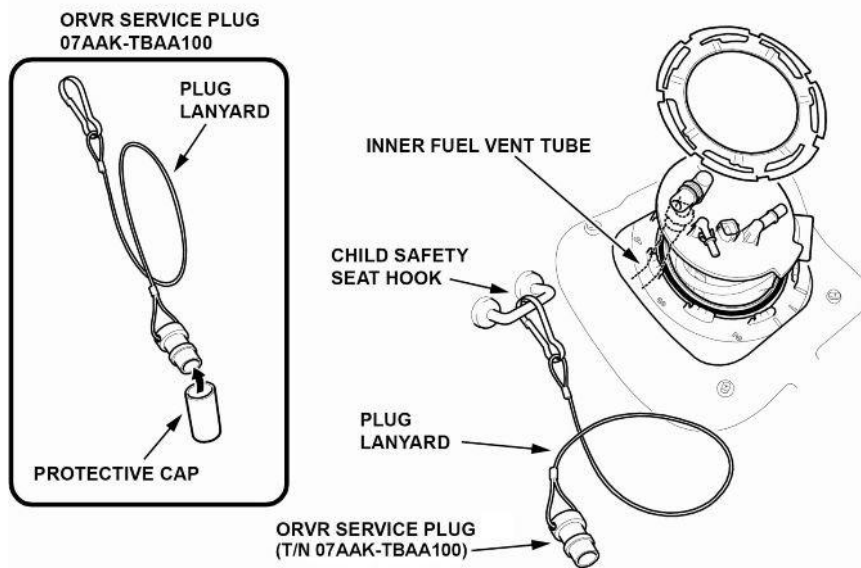

31. Disconnect the inner fuel vent tube from the fuel tank unit, and hold it.

NOTICE

Do not allow the inner fuel vent tube to fall inside the fuel tank before installing the ORVR service plug to it. If fuel enters the inner fuel vent tube, a DTC will set and the inner fuel vent tube will need to be replaced.

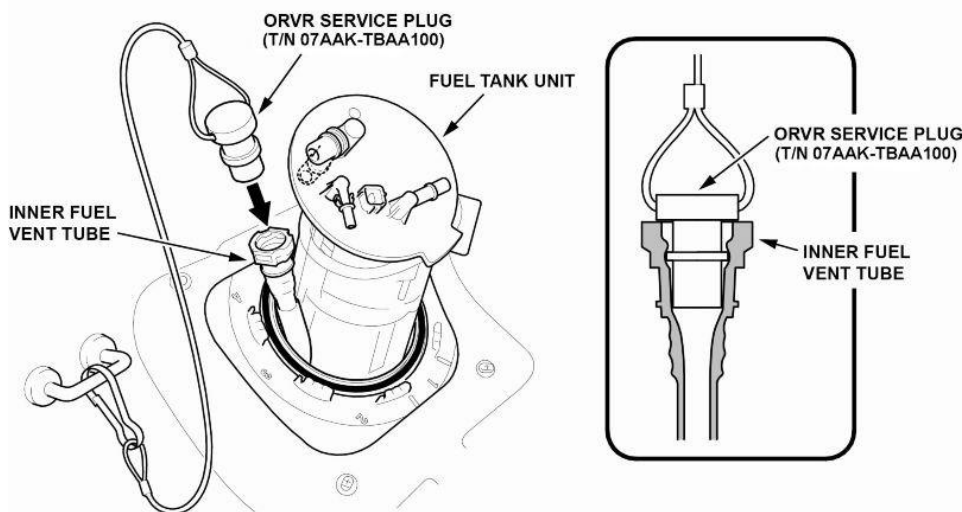

32. Install the ORVR service plug to the inner fuel vent tube. Make sure the ORVR service plug is fully seated by holding the inner fuel vent tube and gently pulling on the plug's lanyard.

NOTE: The ORVR service plug should not come off.

33. Carefully lower the inner fuel vent tube into the fuel tank while making sure the plug lanyard is free and away from the fuel tank unit.

NOTE: It is OK for the plugged tube to be submerged in the fuel.

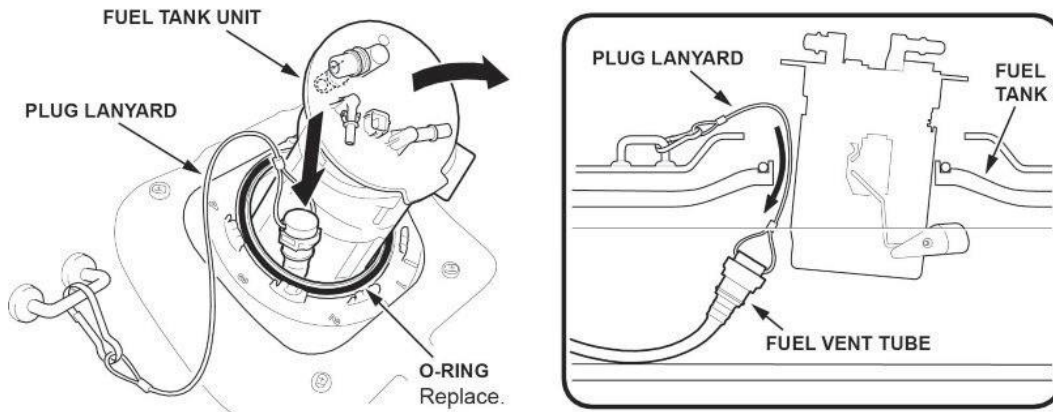

34. Remove the fuel tank unit with the O-ring.

NOTICE

Do not to bend or twist the fuel level sensor arm excessively. This may damage the fuel level sensor or cause it to send inaccurate readings.

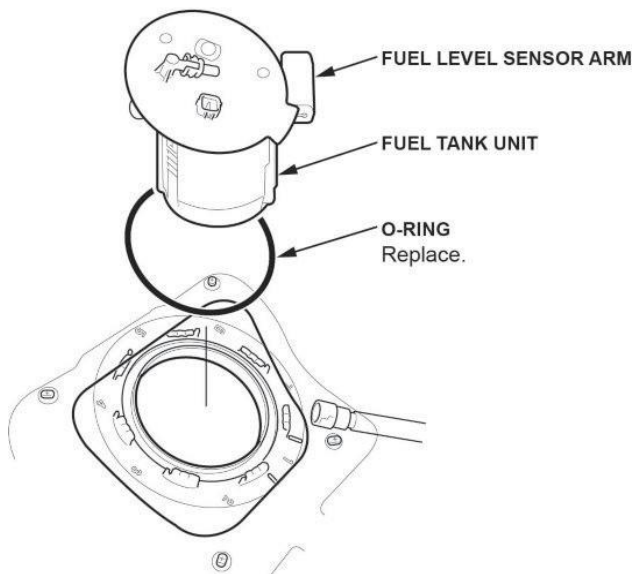

35. Prepare the fuel tank unit and parts to be replaced.

NOTE: Take a photo of the fuel tube and wire harness, and note their routing for assembly. There are various types of routing.

36. Spread the wire harness clamps, and remove the wire harness. Make sure not to damage the wire harness.

NOTICE

Do not spread the clamps too wide. Spreading them too wide may damage them.

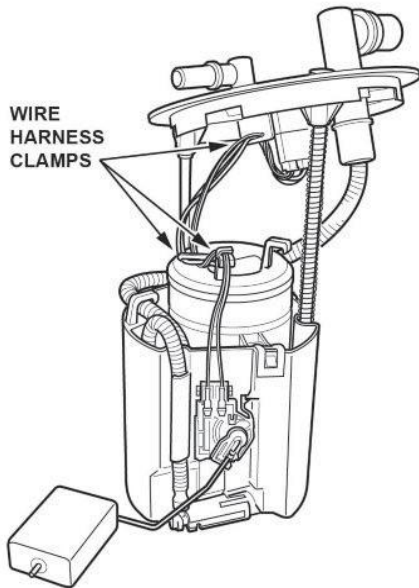

37. Press the tab on the fuel level sensor to release the lock. Then, push up on the fuel level sensor.

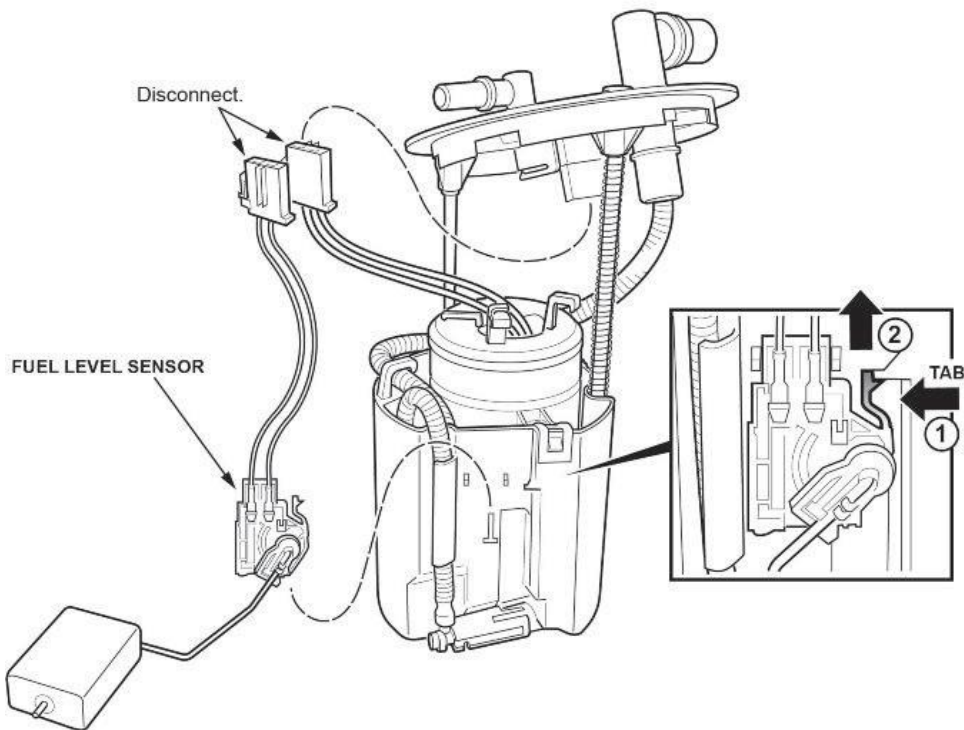

38. Disconnect the fuel level sensor harness and remove the fuel level sensor from the fuel tank unit.

39. Remove the E-ring, and discard it.

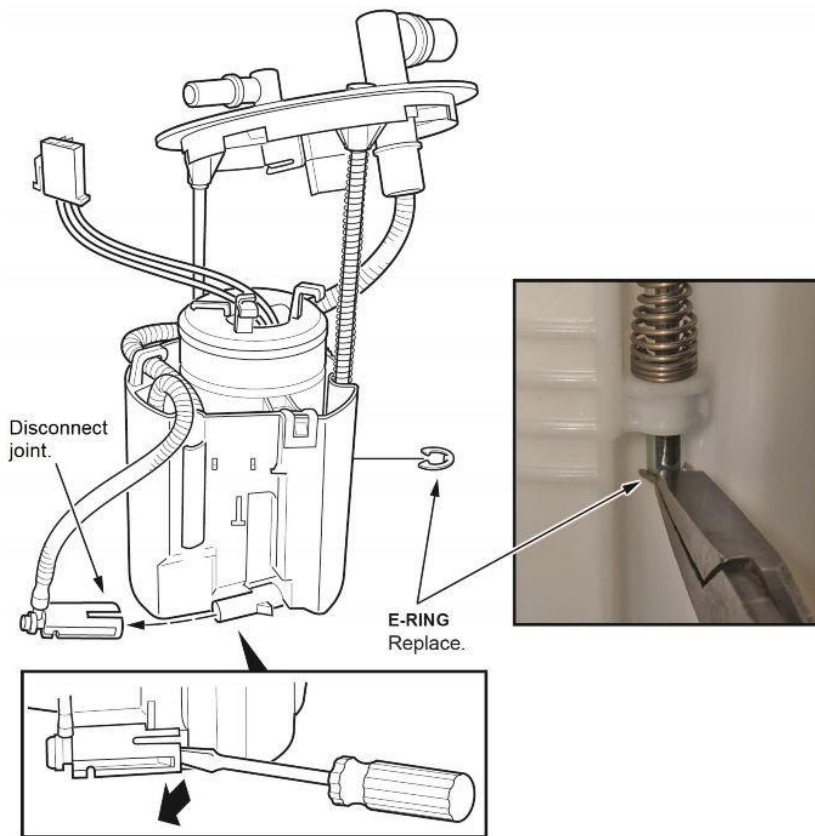

40. Disconnect the joint at the bottom of the reservoir.

41. Remove the fuel filter assembly from the reservoir by releasing the three clips.

NOTICE

Do not spread the clips too wide. Spreading them too wide may damage them.

NOTE: The spring may slide off the sliding shaft. Retain this spring. It will be used during assembly.

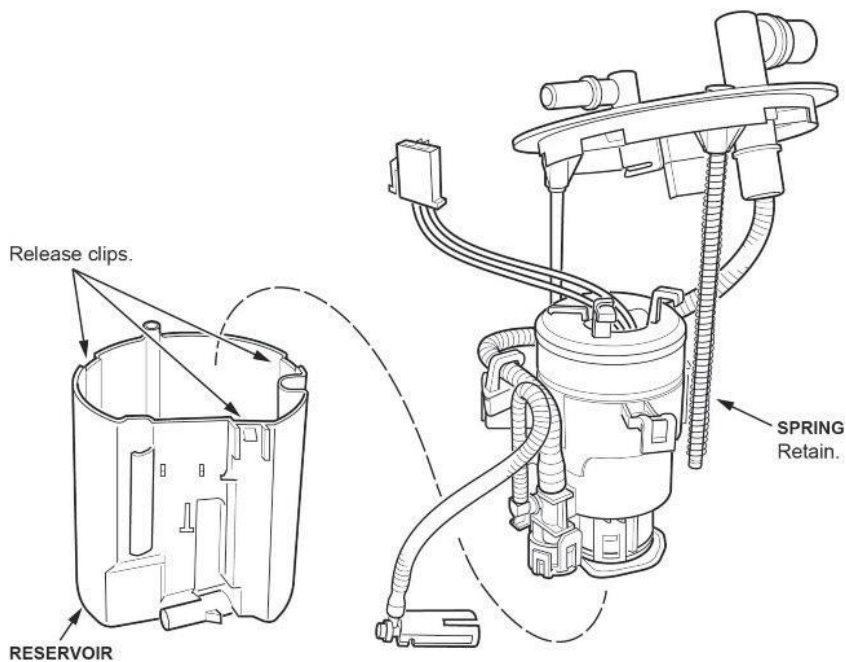

42. Release the three clips at the base of the fuel pump assembly and remove it from the fuel filter.

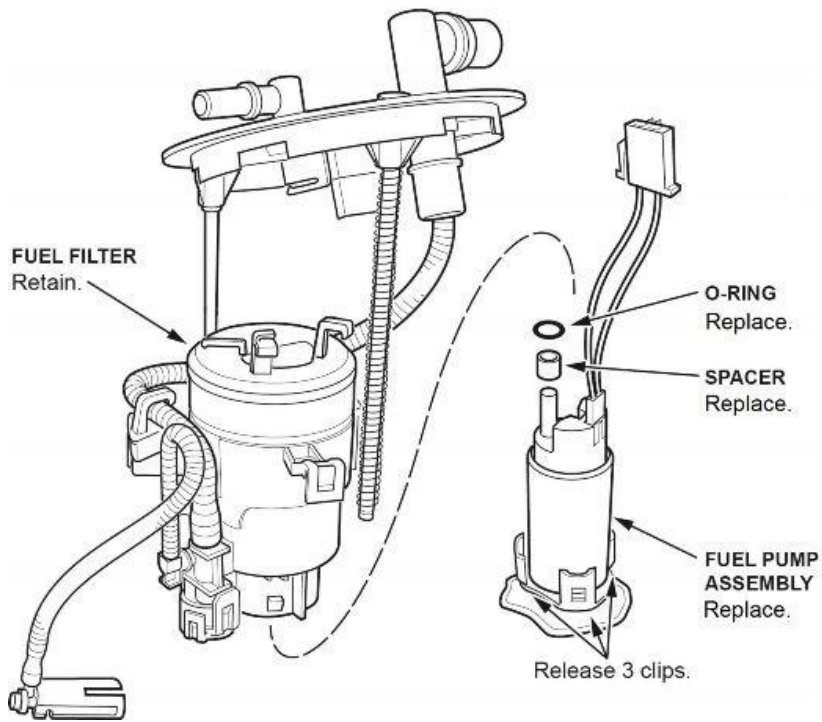

43. Install the new spacer on the new fuel pump motor.

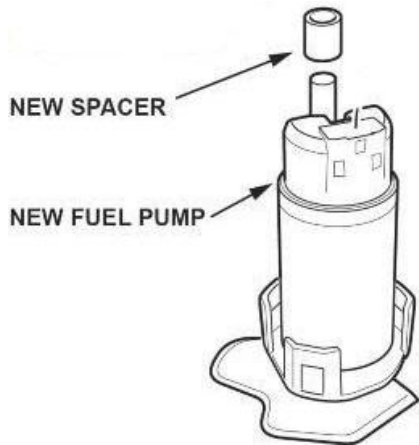

44. Install the new O-ring, then lubricate the outside edge of it, using only clean engine oil.

NOTE: Do not pinch the O-ring during installation.

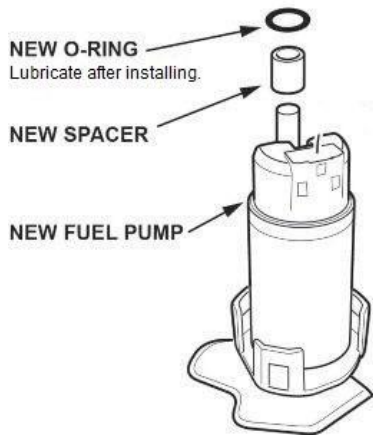

45. Install the new harness and make sure the connection is secure and the connectors are firmly locked into place.

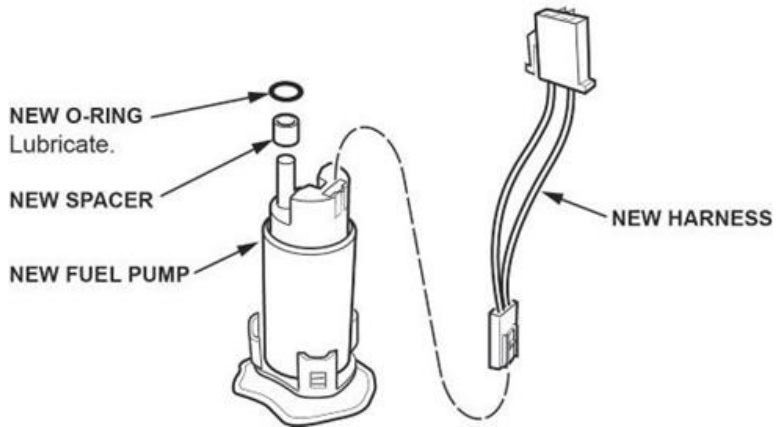

46. Install the fuel pump into the fuel filter.

- Be careful inserting the suction filter so it doesn't break. Use the palm of your hand to push in the entire surface of the suction filter into the module.
- After installing the fuel pump to the strainer, move the lock part of the suction filter back and forth to make sure there is no rattling.
- If installation with a single push is not accompanied by a click, remove all of the parts, reset the O-ring, then assemble again.
- The O-ring cannot be reused once assembled. Replace it with a new one, then reassemble.
- Make sure the flange does not hit other items, because this may lead to a fuel leak.

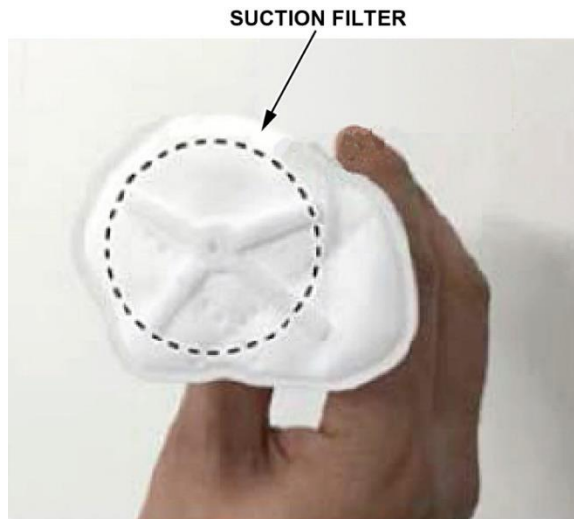

GOOD



NO GOOD

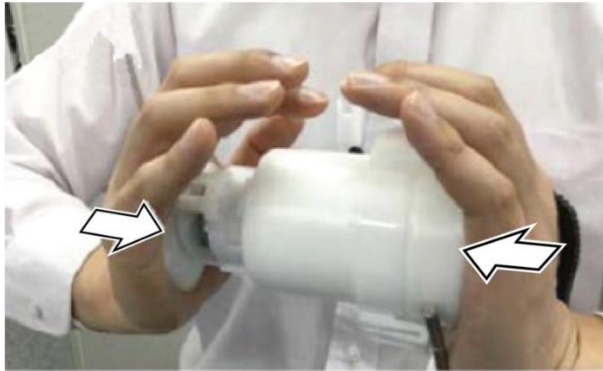

47. Install the fuel filter assembly to the reservoir.

NOTE:

- Insert the spring into the sliding shaft, and make sure it is lined up when installing the fuel filter.
- Make sure to route the fuel tube **exactly** as shown in the photo taken before disassembly.
- Make sure the three clips are fully engaged.

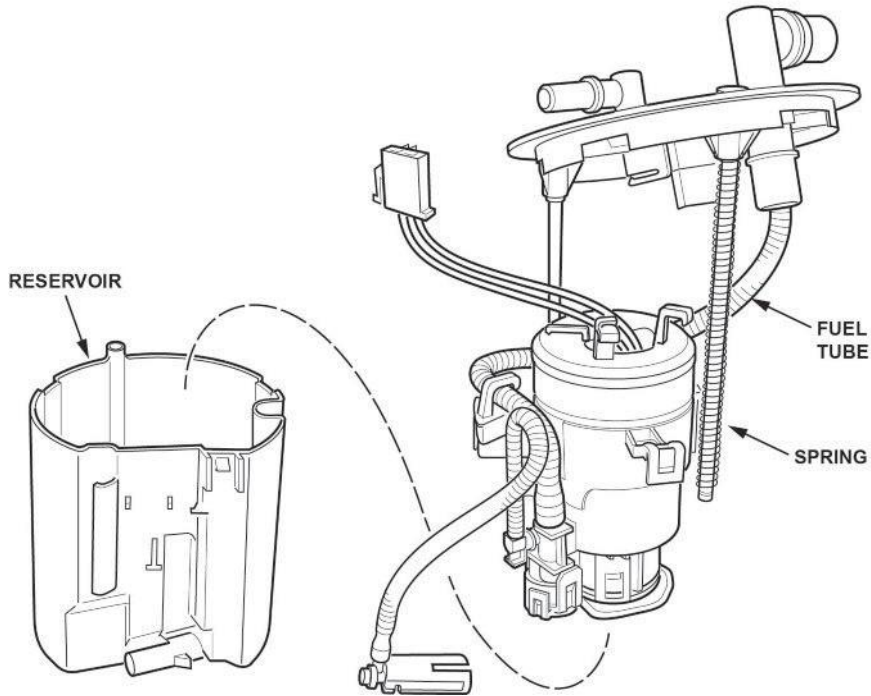

48. Install the new E-ring.

NOTE: After installation, make sure the E-ring can be rotated with your finger. If it cannot be rotated, the E-ring may not be fully seated or may be incorrectly installed.

49. Install the fuel level sensor to the reservoir. Make sure the lock is engaged and the connection is secure.

NOTICE

Do not to bend or twist the fuel level sensor arm excessively. This may damage the fuel level sensor or cause it to send inaccurate readings.

50. Install the wiring harness to the clamps.

NOTICE

Do not spread the clips too wide. Spreading them too wide may damage them.

NOTE:

- Clip in the smaller harness wires followed by the larger wires.
- Make sure not to damage the wire harness.
- Make sure to route the wire harness **exactly** as shown in the photo taken before disassembly.

HARNES ROUTING:

Clip in the smaller harness wires followed by the larger wires.

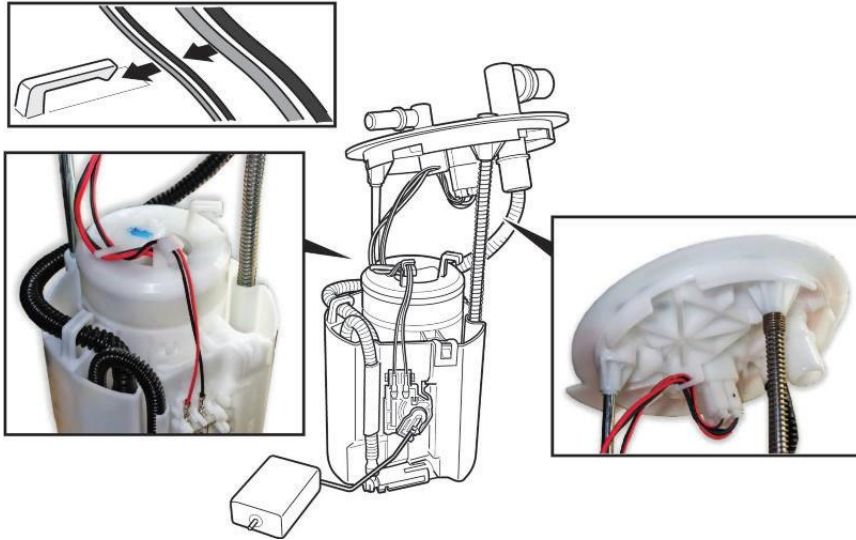

51. While compressing the fuel tank unit, make sure the movement is smooth and the fuel tube and wiring harness do not stretch, pinch, or bind.

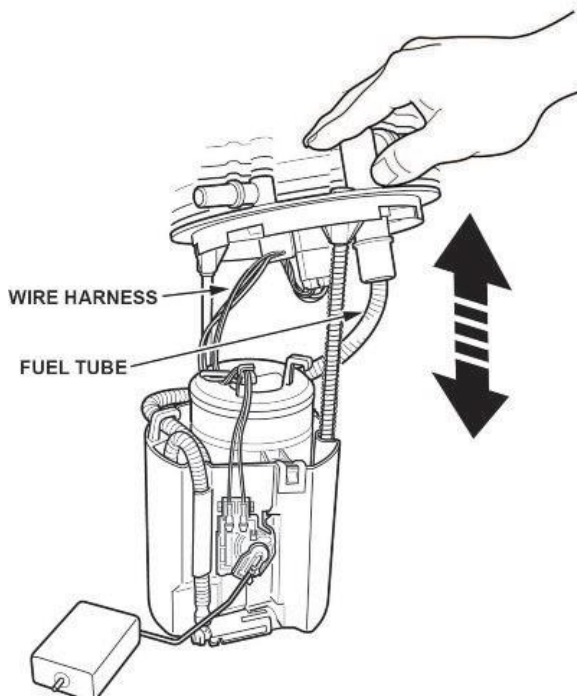

52. Install a new O-ring on the fuel tank.

NOTE:

- Before installing the new O-ring, clean the fuel tank around the fuel pump opening where the O-ring will seat. The tank opening must be free of dirt, dust, and debris.
- Be careful not to damage the O-ring.
- Do not coat the O-ring with any oil.

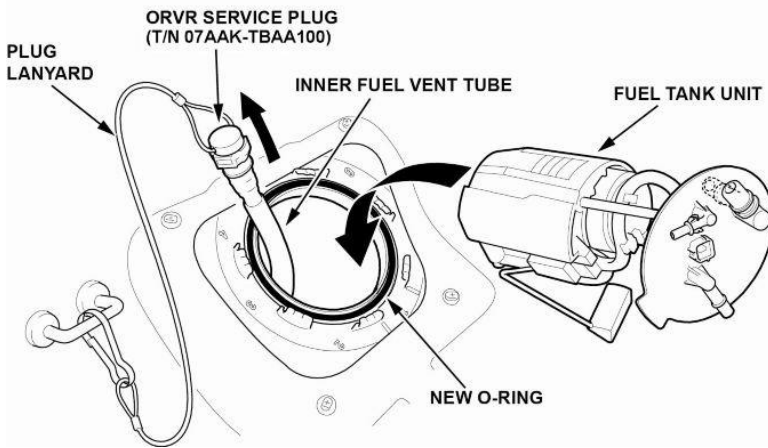

53. Grab the plug lanyard, and pull the inner fuel vent tube up until it is close to the fuel tank opening. Hold the tube while installing the fuel tank unit.

54. Move the fuel tank unit aside, and remove the ORVR service plug from the inner fuel vent tube.

NOTICE

Do not allow the inner fuel vent tube to fall inside the fuel tank before installing the ORVR service plug to it. If fuel enters the inner fuel vent tube, a DTC will set and the inner fuel vent tube will need to be replaced.

55. Move the ORVR service plug away from the tank opening, and connect the inner fuel vent tube to the fuel tank unit.

NOTICE

Do not to bend or twist the fuel level sensor arm excessively. This may damage the fuel level sensor or cause it to send inaccurate readings.

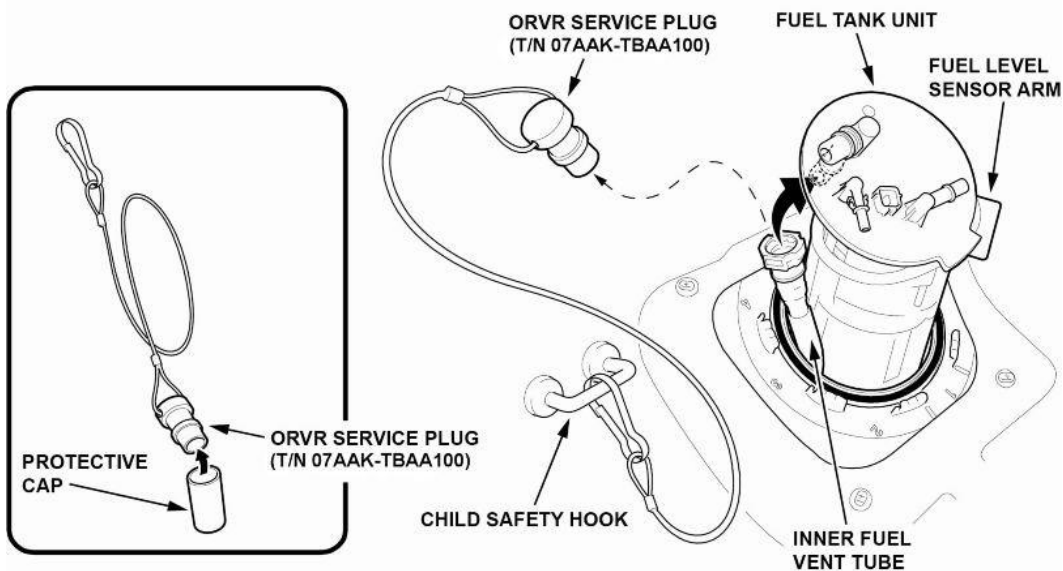

56. Remove the ORVR service plug from the child safety seat hook, and install the provided protective cap.

57. Line up the tab of the fuel tank unit as shown, and partially install the new fuel tank unit cam lock ring with a new O-ring.

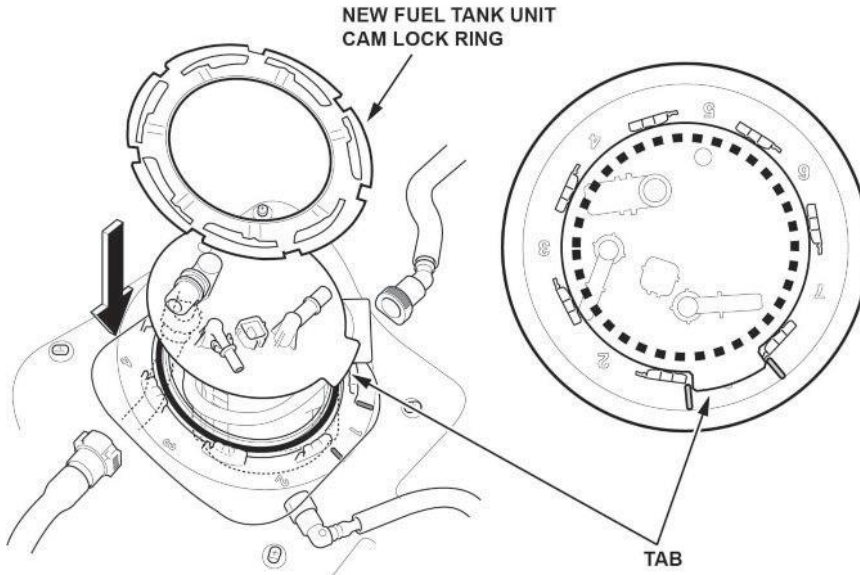

58. Connect the fuel vent tube and fuel tank vapor recirculation tube by slightly turning the fuel tank unit counterclockwise.
NOTE: Do not bend the fuel vent tube and fuel tank vapor recirculation tube excessively.

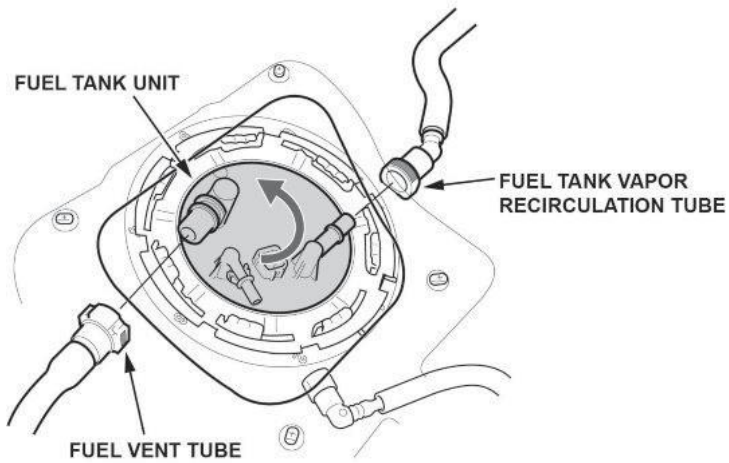

59. Turn the fuel tank unit cam lock ring by hand, and slide the fuel tank unit cam lock tabs to the positioning edge as shown.

NOTICE

Make sure the fuel cam lock ring is not floating. If the cam lock ring is not properly installed, the fuel tank can be damaged and will require replacement.

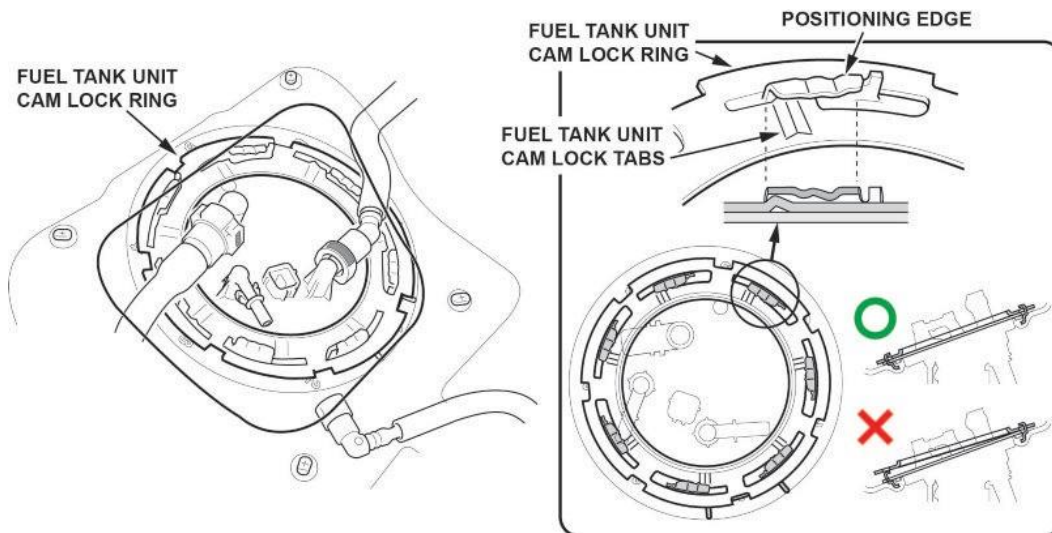

60. Tighten the fuel tank unit cam lock ring by turning clockwise using the fuel sender wrench.

NOTE:

- Keep the fuel sender wrench from floating.
- Securely set the positioning edge of the fuel tank to the tabs on the cam lock ring as shown.

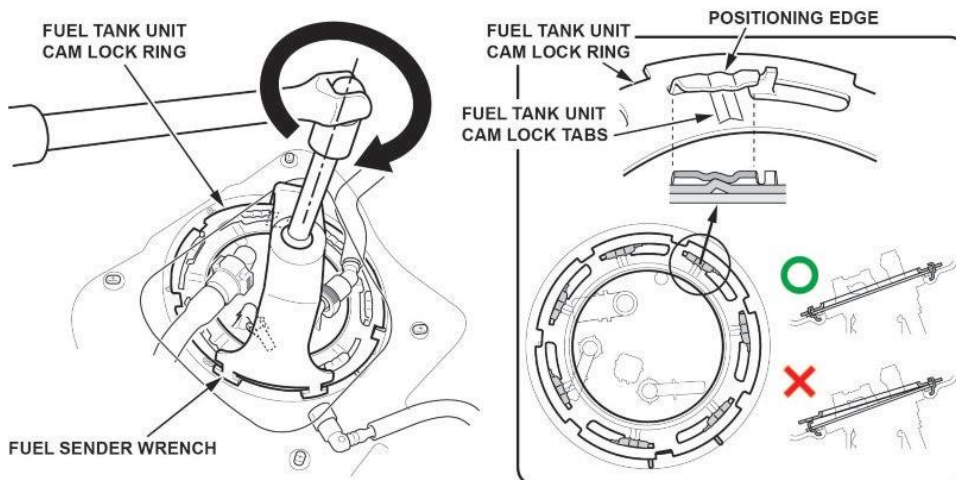

61. Remove the quick-connect fitting retainer from the fuel tank unit, then install a new retainer onto the quick-connect fitting.

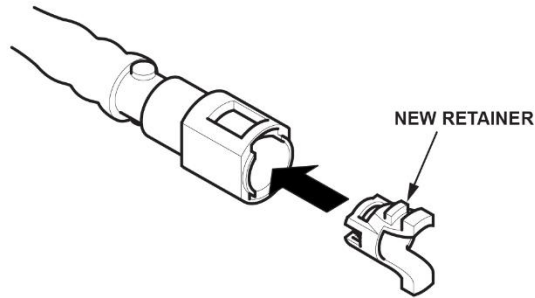

62. Connect the fuel line quick-connect fitting and connector.

NOTE: Install the connector cover if it was removed.

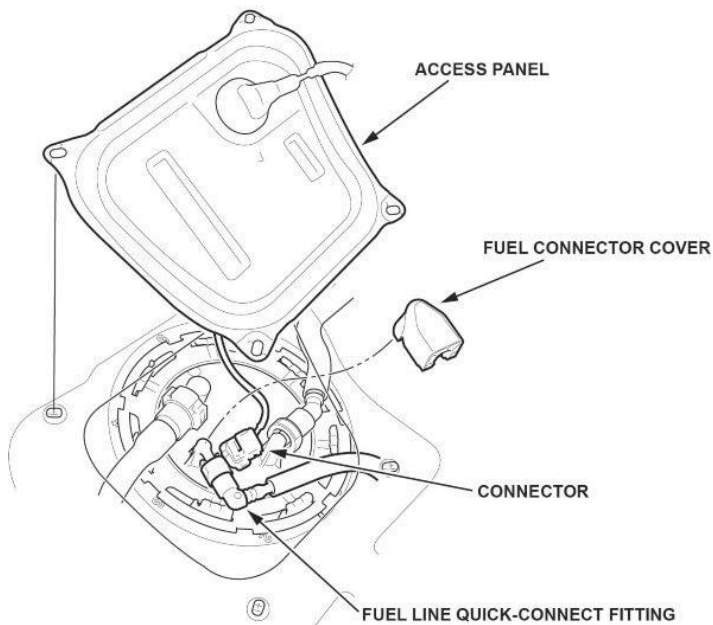

63. Connect the 12-volt battery terminals.
64. Turn the ignition to ON, but do not turn the engine on. After the fuel pump runs for about **2 seconds**, the fuel line will be pressurized. Repeat this two or three times, then make sure there is no fuel leakage.
65. Install the fuel tank unit access panel.
66. Install the remaining parts in the reverse order of removal.
67. Clear all DTCs using an i-HDS.
68. Do the VSA sensor neutral position memorization procedure.

