

September 30, 2022

Version 3

Safety Recall: 2019 HR-V (AWD) Fuel Pump MotorSupersedes 21-025, dated July 30, 2021, to revise the information highlighted in **yellow****AFFECTED VEHICLES**

Year	Model	Trim Level	VIN Range
2019	HR-V (AWD)	ALL	Check the iN VIN status for eligibility.

REVISION SUMMARY

Under REPAIR PROCEDURE, step 29 was revised.

BACKGROUND

Due to swelling of the fuel pump motor impeller, the fuel pump may seize and stop working. If this occurs, the check engine light may be displayed with DTC P0087 (Fuel Rail Pressure Too Low) stored, the engine may not start, or the engine could stall while driving, increasing the risk of a crash.

CUSTOMER NOTIFICATION

Owners of affected vehicles will be sent a notification of this campaign.

Do an iN VIN status inquiry to make sure the vehicle is shown as eligible.

Failure to repair a vehicle subject to a recall or campaign may subject your dealership to claims or lawsuits from the customer or anyone else harmed as a result of such failure. To see if a vehicle in inventory is affected by this safety recall, do a VIN status inquiry before selling it.

CORRECTIVE ACTION

Replace the fuel pump motor.

NOTE: If the vehicle has any of the symptoms listed in BACKGROUND, you must apply this bulletin before attempting any other repairs. If the symptoms remain after the recall repair is complete, only attempt further repairs (such as replacing the high pressure fuel pump) after authorized troubleshooting.

CUSTOMER INFORMATION: The information in this bulletin is intended for use only by skilled technicians who have the proper tools, equipment, and training to correctly and safely maintain your vehicle. These procedures should not be attempted by "do-it-yourselfers," and you should not assume this bulletin applies to your vehicle, or that your vehicle has the condition described. To determine whether this information applies, contact an authorized Honda automobile dealer.

PARTS INFORMATION

NOTE: Due to limited supply, this is a controlled part and will require a valid VIN when ordering.

Part Name	Part Number	Quantity
Fuel Pump Motor Kit	06170-T7L-305	1

For dealers experiencing a strong fuel smell from storing a fuel pump motor replaced under this service bulletin, the fuel pump motor may be disposed of immediately in accordance with local regulations. This only applies to the fuel pump motor replaced under this service bulletin. The published retention policy remains in effect for all other parts.

If you have any questions about this exception or other parts retention issues, contact the WPI Administrative Office at **937-642-2737**.

TOOL INFORMATION

Tool Name	Part Number	Quantity
Fuel Nut Wrench (Fuel Sender Wrench)	070AA-T0AA100 or 07AAA-T0AA100	1

WARRANTY CLAIM INFORMATION

Operation Number	Description	Flat Rate Time	Defect Code	Symptom Code	Template ID	Failed Part Number
3101HK	Replace the fuel pump motor.	1.2 hr	6FE00	WAC00	A21025A	17045-T7X-A01

Skill Level: Repair Technician

REPAIR PROCEDURE

⚠ WARNING

Fuel pump motor removal exposes fuel, which can ignite, causing a fire or explosion.

This can cause serious injury or death.

Always work in a well-ventilated area, and keep sparks or open flames away.

1. Remove the fuel fill cap to relieve the pressure in the fuel tank.
2. Remove the PGM-FI main relay 2 from the under-dash fuse/relay box.

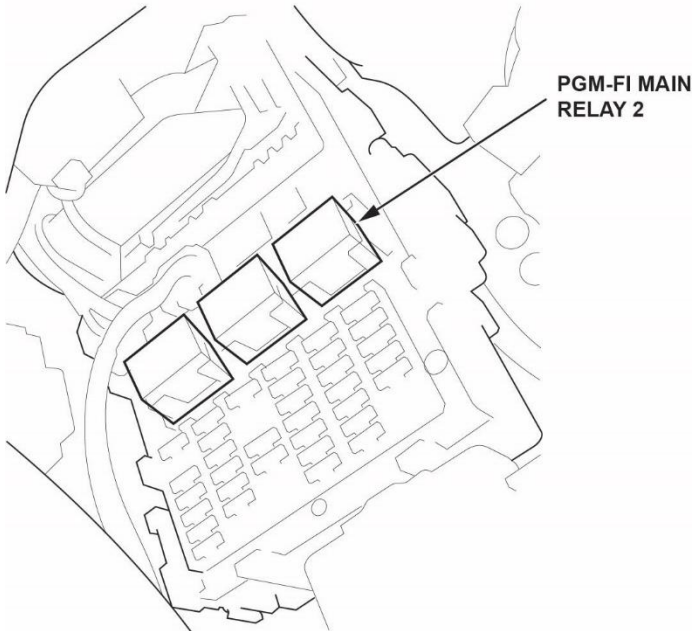

3. Start the engine and let it idle until it stalls.
4. Turn the ignition to OFF.
5. Install the PGM-FI main relay 2.

6. Remove the driver's seat front foot covers (if equipped).

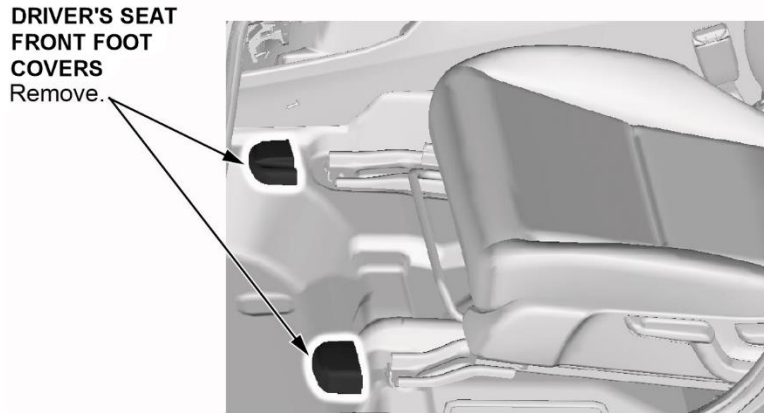

7. Remove the driver's seat rear foot covers (if equipped).

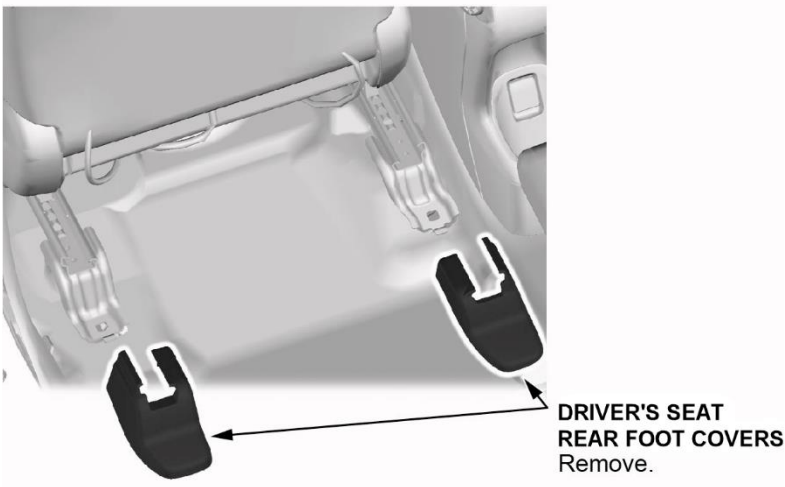

8. Remove the driver's seat mounting bolts.

REAR SIDE

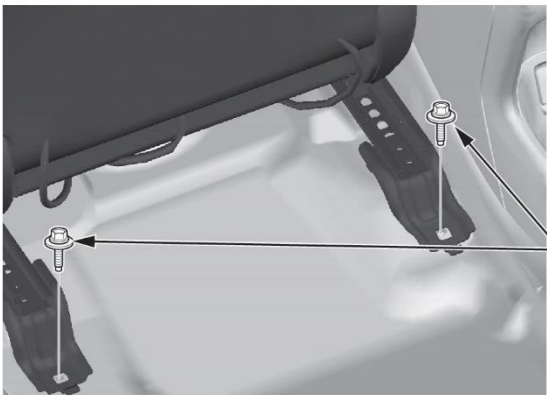

FRONT SIDE

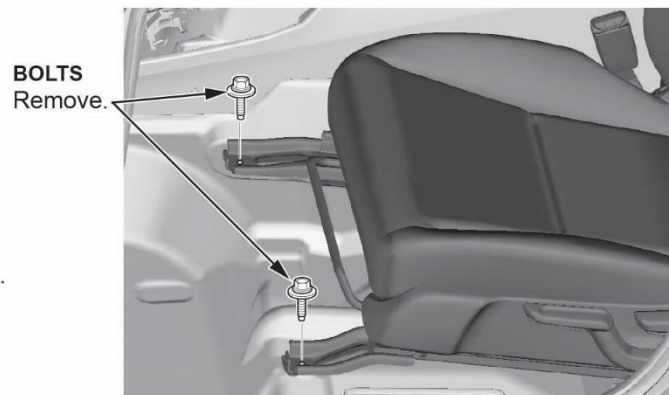

9. Disconnect both 12-volt battery terminals.

NOTICE

To protect the terminal connector from damage, do not hold it when removing the negative terminal.

NOTE:

- Always disconnect the negative terminal first.
- Do not disconnect the 12-volt battery sensor from the cable.

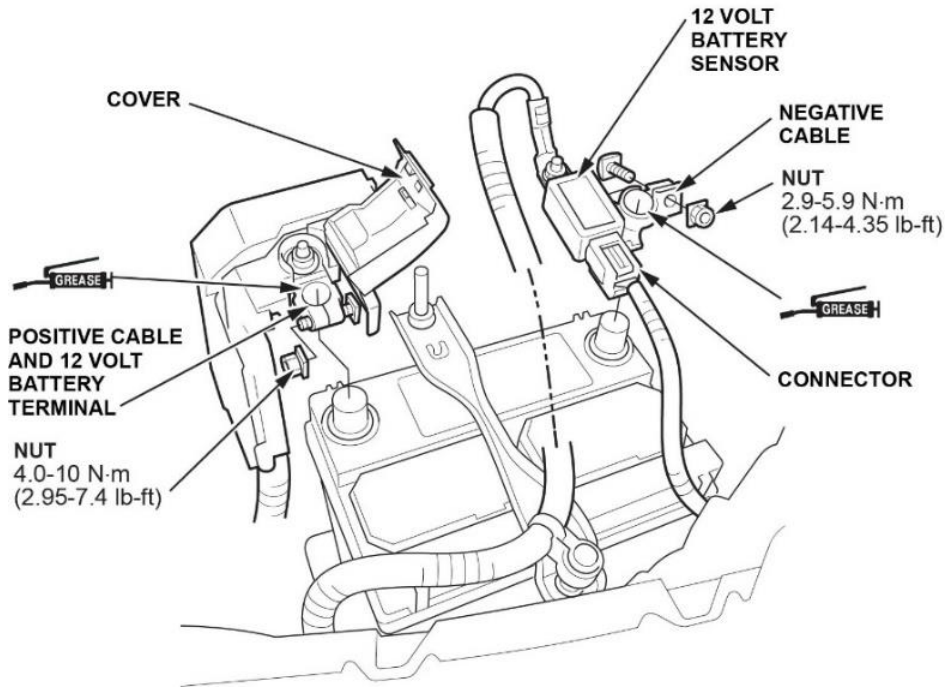

10. Remove the harness clip and connectors as shown.

NOTE: The manual seat is shown below, the power seat is similar.

DRIVER'S SEAT (WITHOUT SEAT POSITION SENSOR)

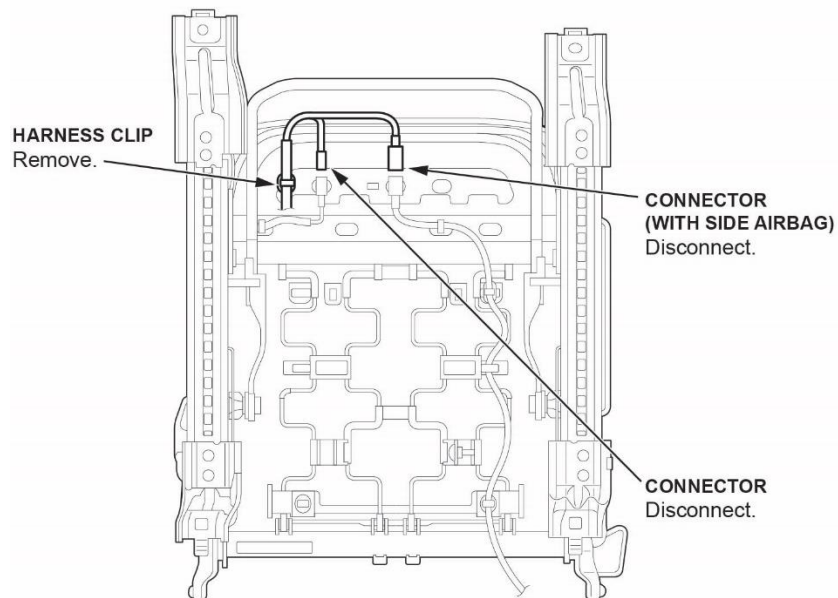

DRIVER'S SEAT (WITH SEAT POSITION SENSOR)

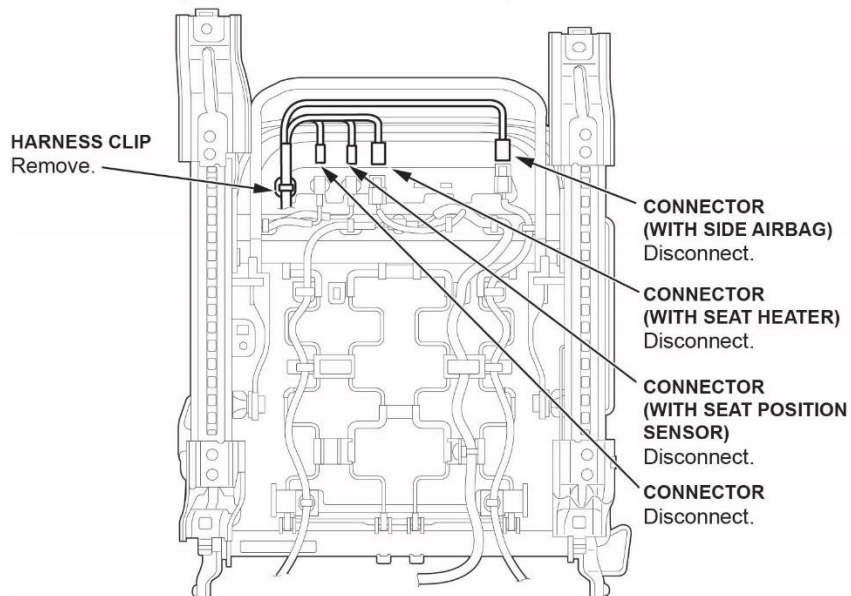

11. Remove the rear heater duct.

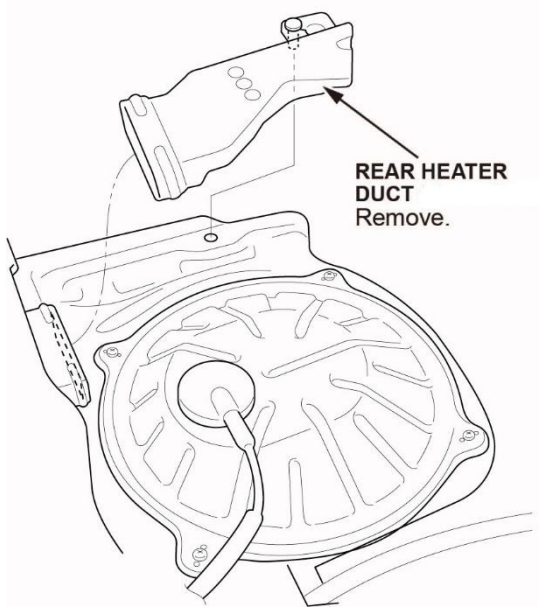

12. Remove the fuel tank unit access panel, and disconnect the connector.

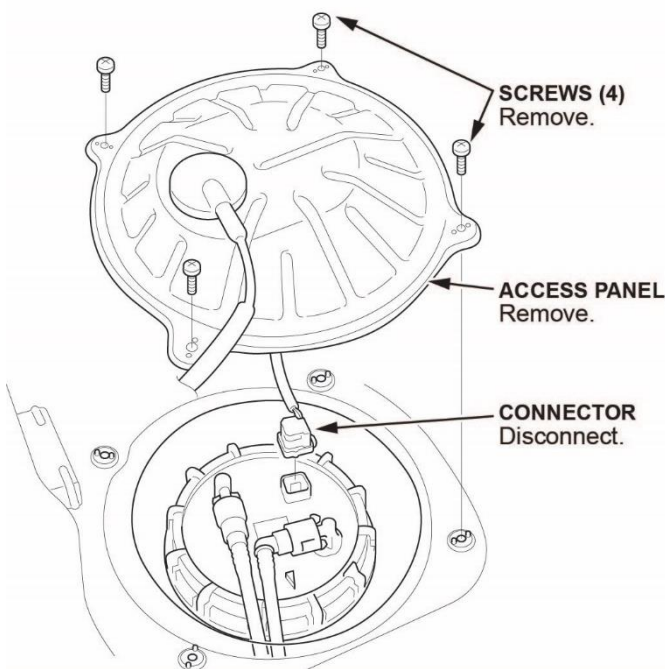

13. Place a rag or shop towel over the quick-connect fittings, and disconnect them.

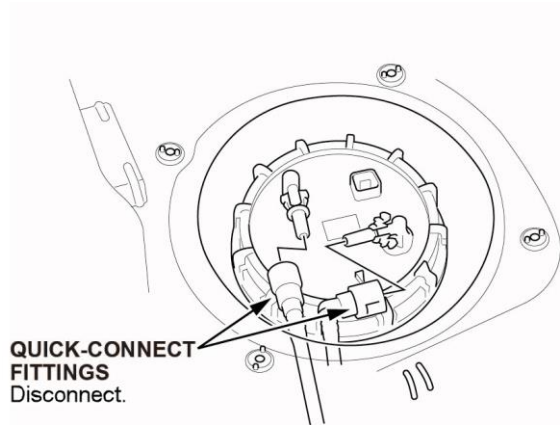

14. Loosen the fuel tank unit locknut using the Fuel Sender Wrench (T/N 070AA-T0AA100 or 07AAA-T0AA100), then remove it.

NOTE: After unlocking the fuel tank unit cam lock ring, clean the top of the fuel pump flange and adjacent areas to make sure it's free of dirt, dust, and debris.

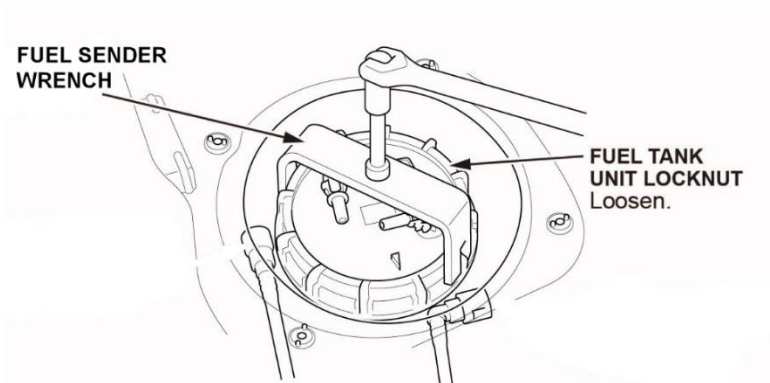

15. Lift the fuel tank unit, and disconnect the transfer tube. Then, remove the fuel tank unit.

NOTICE

Do not bend or twist the fuel level sensor arm excessively. This may damage the fuel level sensor or cause it to send inaccurate readings.

NOTE:

- After removing the fuel pump unit, clean the fuel tank around the fuel pump opening.
- After removing the fuel pump base gasket, clean the fuel tank around the base gasket opening and make sure it's free of dirt, dust, and debris

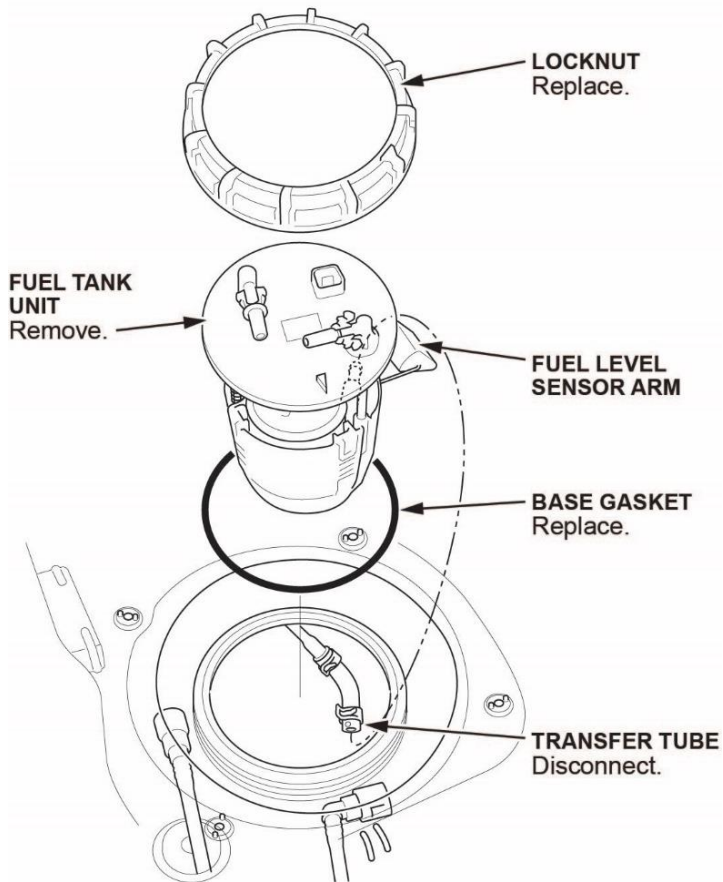

16. Prepare the fuel pump and parts to be replaced.

NOTE: Take a photo of the fuel tube and wire harness, and note their routing for assembly. There are various types of routing.

17. Spread the wire harness clamps, and remove the wire harness. Make sure not to damage the wire harness.

NOTICE

Do not spread the clamps too wide. Spreading them too wide may damage them.

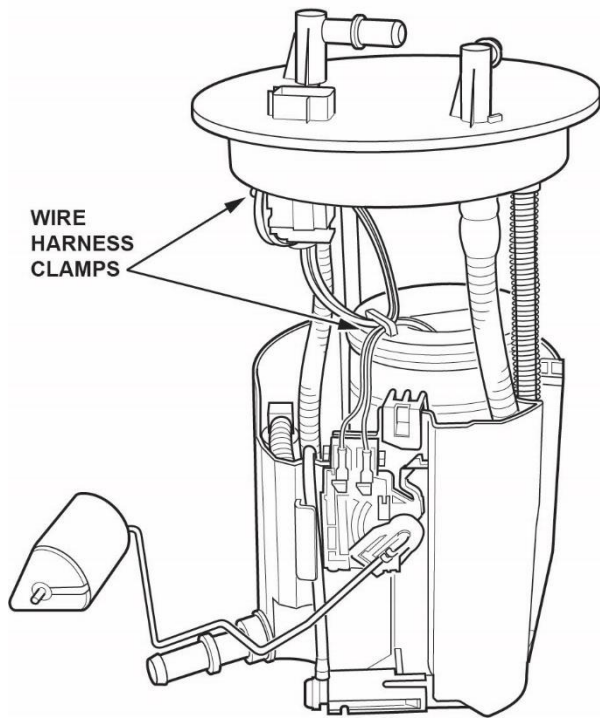

18. Press the tab on the fuel level sensor to release the lock. Then, push up on the fuel level sensor.

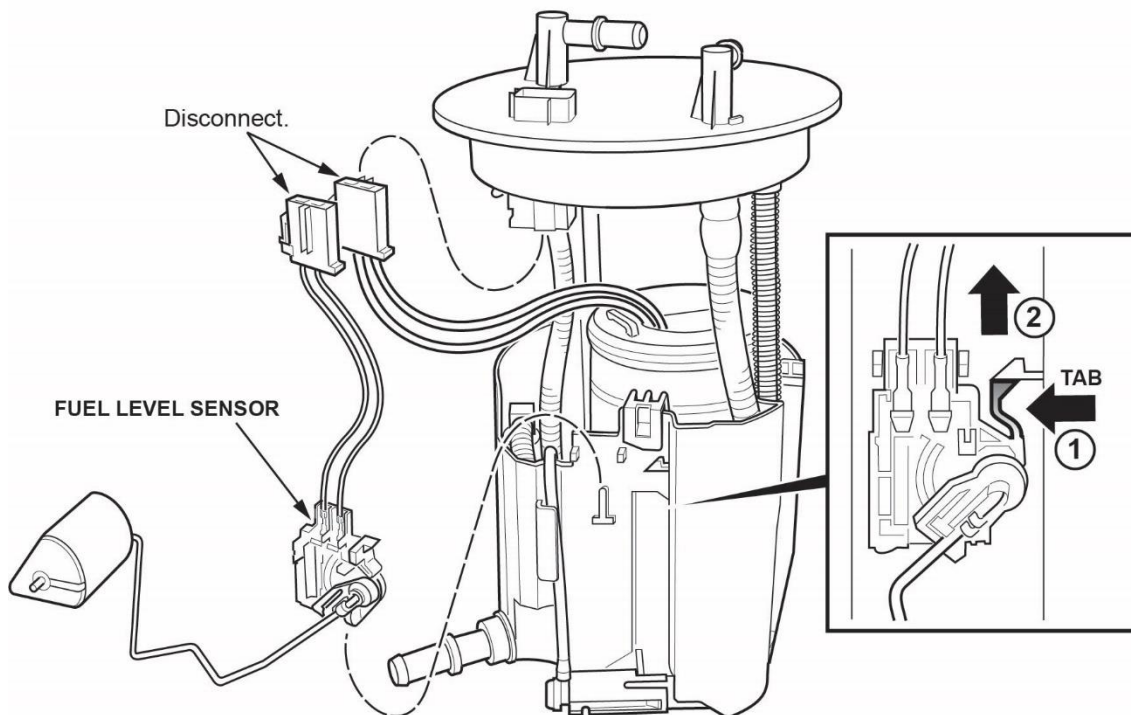

19. Disconnect the fuel level sensor harness and remove the fuel level sensor from the fuel tank unit.

20. Remove the E-ring and discard it.

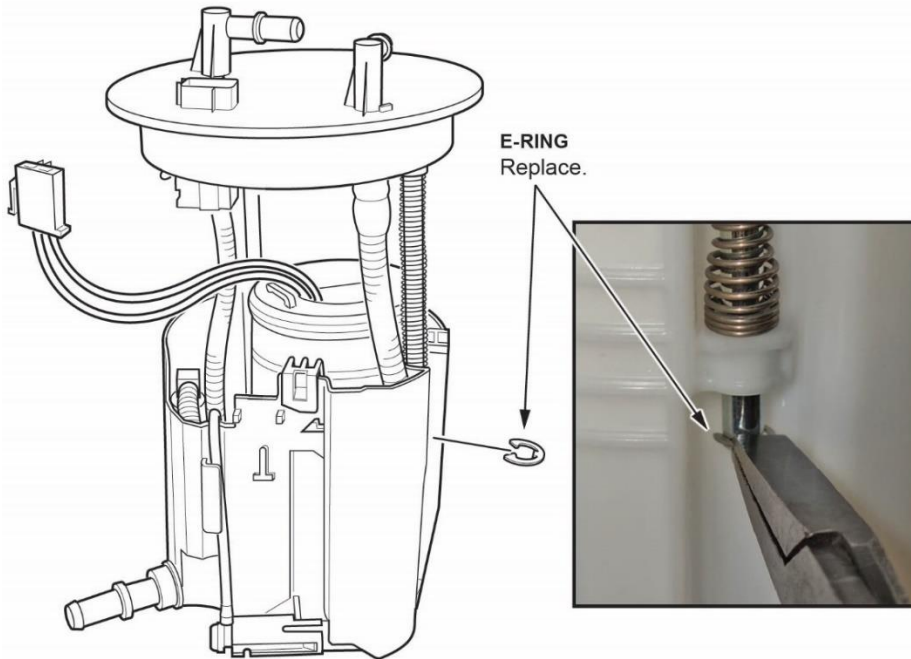

21. Use an O-ring pick to disconnect joint A inside the reservoir.

NOTE: If the O-ring remains inside the joint, use a flat-tip screwdriver wrapped in protective tape to remove it. Take care not to damage the O-ring seat section.

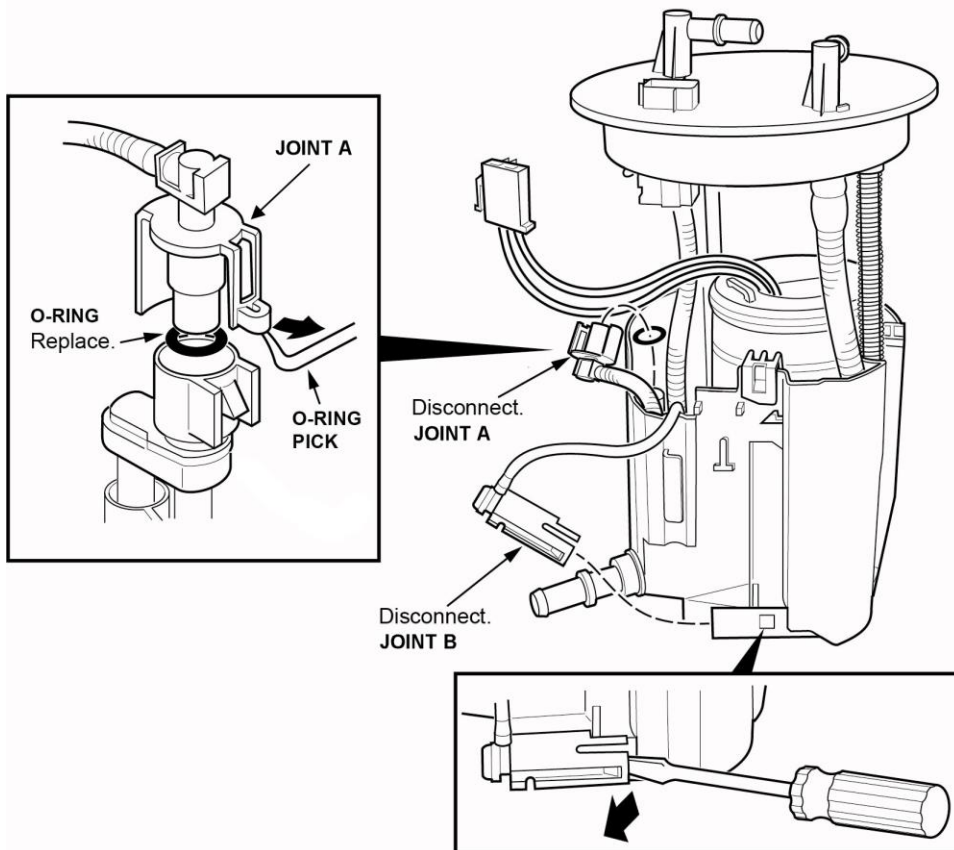

22. Disconnect joint B from the bottom of the reservoir.

23. Remove the fuel filter assembly from the reservoir by releasing the three clips.

NOTE: The spring may slide off the sliding shaft. Retain this spring. It will be used during assembly.

NOTICE

Do not spread the clips too wide. Spreading them too wide may damage them.

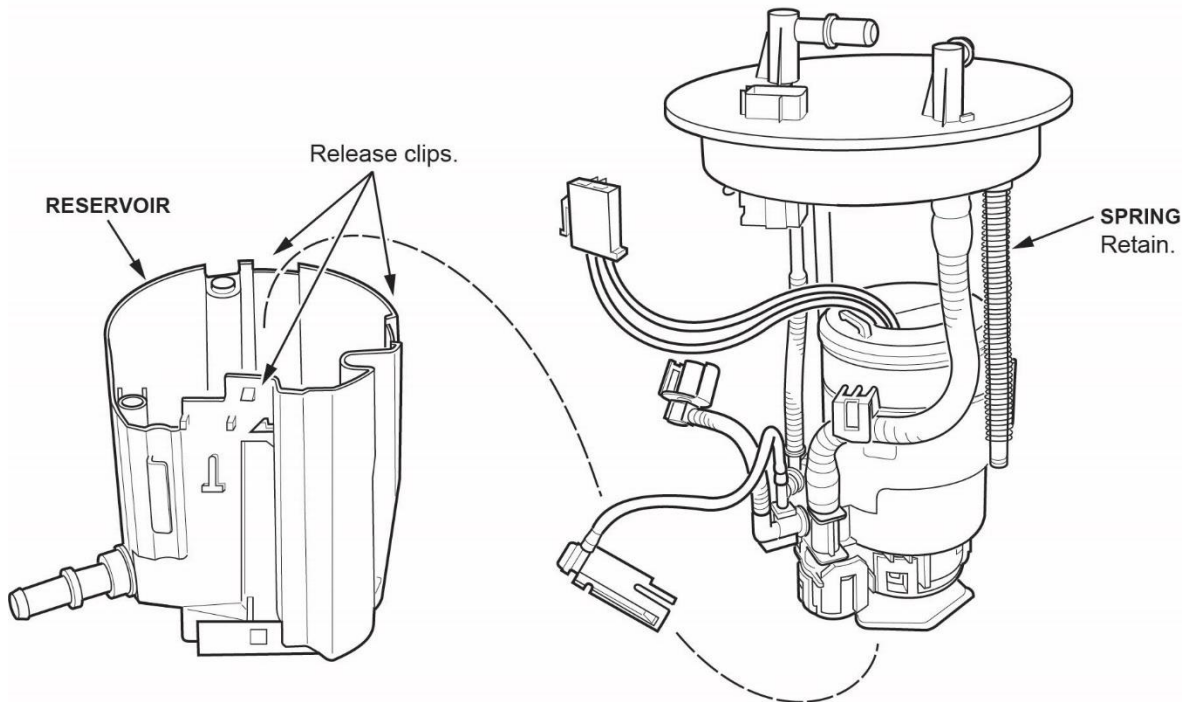

24. Release the three clips at the base of the fuel pump assembly and remove it from the fuel filter.

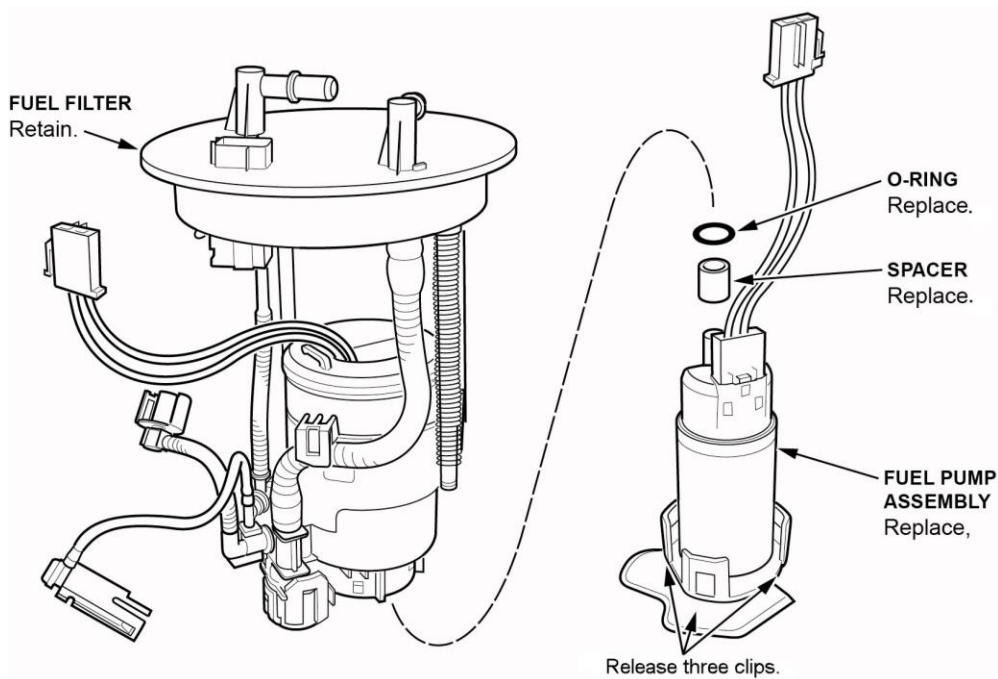

25. Pull the fuel pump assembly out of the fuel filter.

NOTE: If the O-ring remains on the fuel filter, use a flat-tip screwdriver wrapped in protective tape to remove it. Make sure not to damage the O-ring seat section.

26. Install the new spacer on the new fuel pump motor.

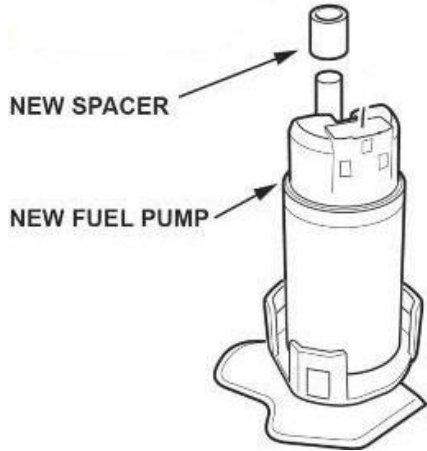

27. Install the new O-ring, then lubricate the outside edge of it, using only clean engine oil.

NOTE: Do not pinch the O-ring during installation.

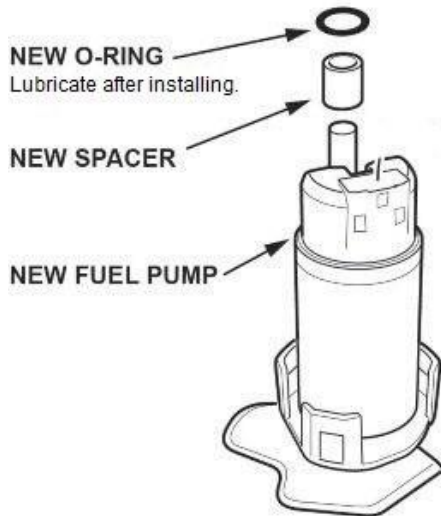

28. Install the new harness and make sure the connection is secure and the connectors are firmly locked into place.

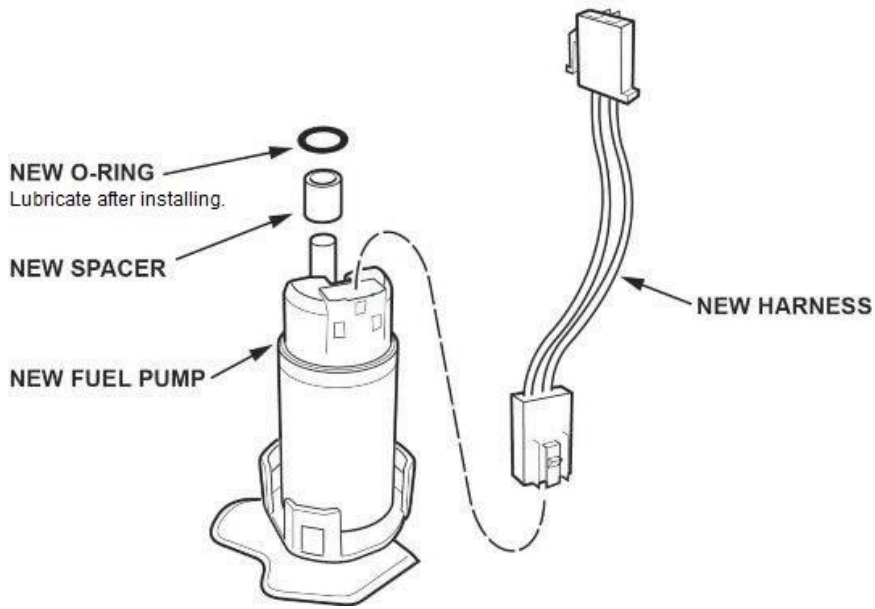

29. Install the fuel pump into the fuel filter.

- Be careful inserting the suction filter so it doesn't break. Use the palm of your hand to push in the entire surface of the suction filter into the module.
- After installing the fuel pump to the strainer, move the lock part of the suction filter back and forth to make sure there is no rattling.
- If installation with a single push is not accompanied by a click, remove all of the parts, reset the O-ring, then assemble again.
- The O-ring cannot be reused once assembled. Replace it with a new one, then reassemble.
- Make sure the flange does not hit other items, because this may lead to a fuel leak.

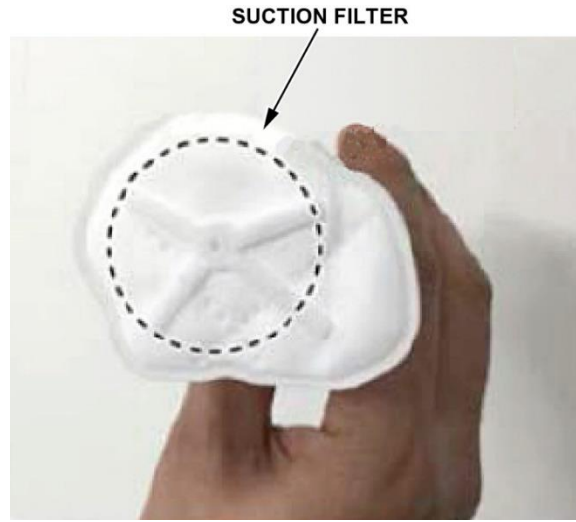

GOOD



NO GOOD

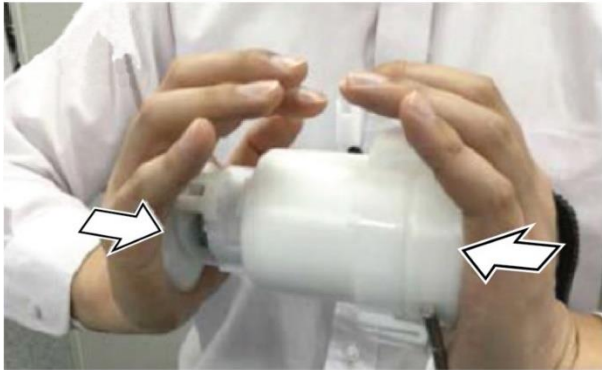

30. Install the fuel filter assembly to the reservoir.

NOTE:

- Install a new O-ring on joint A before connecting it.
- Coat the O-ring with clean engine oil; do not use any other oil or fluid.
- Do not pinch the O-ring during installation.
- Insert the spring into the sliding shaft, and make sure it is lined up when installing the fuel filter.
- Make sure the fuel tube is routed **exactly** as shown in the photo taken before disassembly.
- Make sure the three clips are fully engaged.

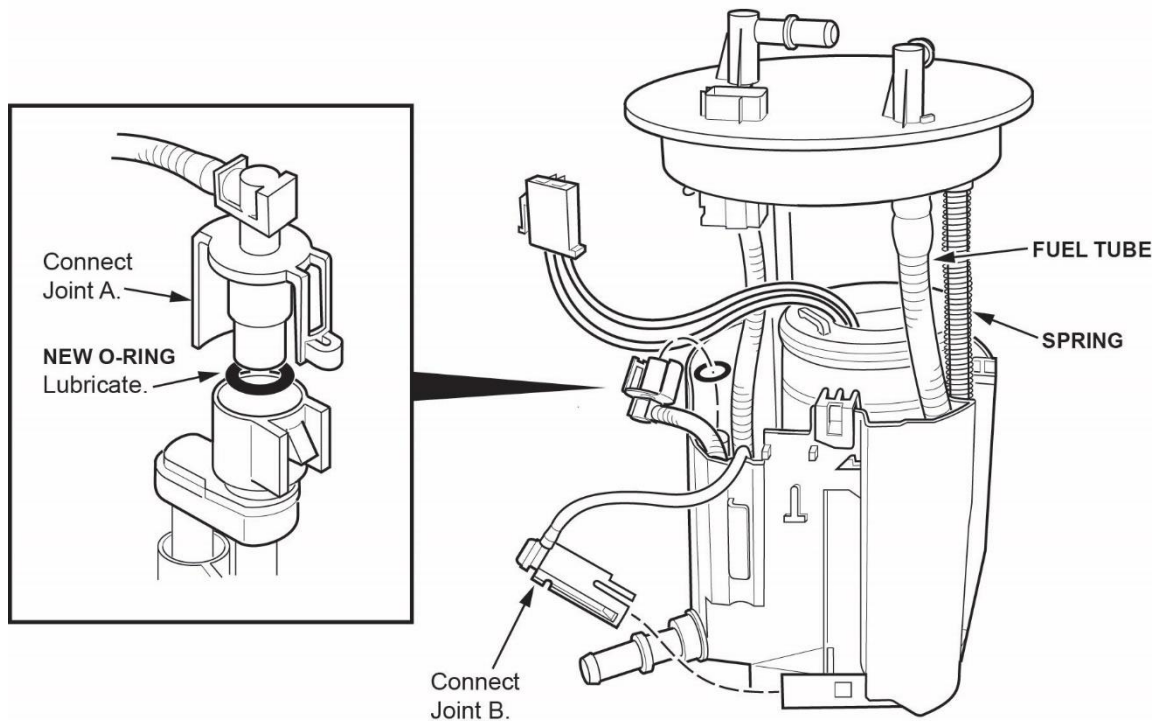

31. Connect joint B.

32. Install the new E-ring.

NOTE: After installation, make sure the E-ring can be rotated with your finger. If it cannot be rotated, the E-ring may not be fully seated or may be incorrectly installed.

33. Install the fuel level sensor to the reservoir. Make sure the lock is engaged and the connection is secure.

NOTICE

Do not bend or twist the fuel level sensor arm excessively. This may damage the fuel level sensor or cause it to send inaccurate readings.

32. Install the wiring harness to the clamps.

NOTICE

Do not spread the clamps too wide. Spreading them too wide may damage them.

NOTE:

- Clip in the smaller harness wires followed by the larger wires.
- Make sure not to damage the wire harness.
- Make sure to route the wire harness **exactly** as shown in the photo taken before disassembly.

HARNESS ROUTING

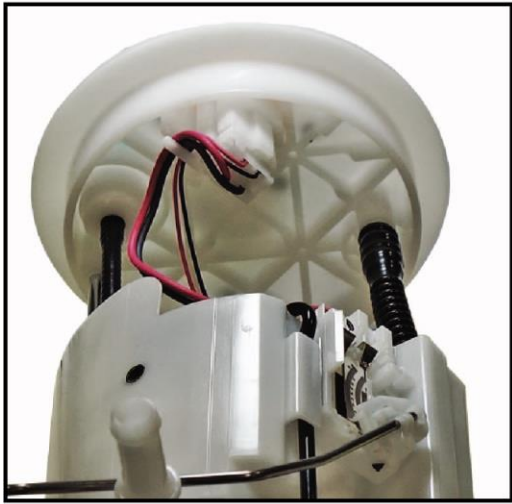

Clip in the smaller harness wires followed by the larger wires.

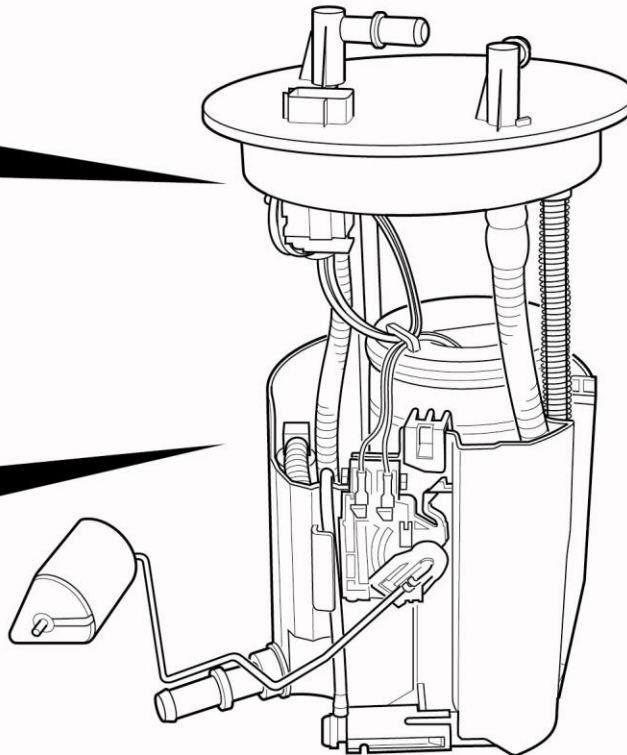
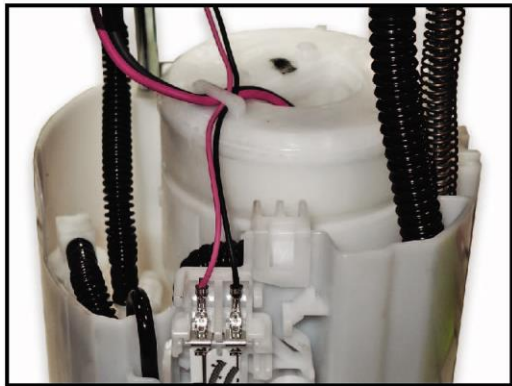
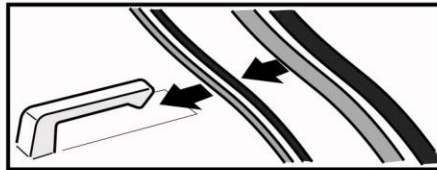

33. While compressing the fuel tank unit, make sure the movement is smooth and the fuel tube and wiring harness do not stretch, pinch, or bind.

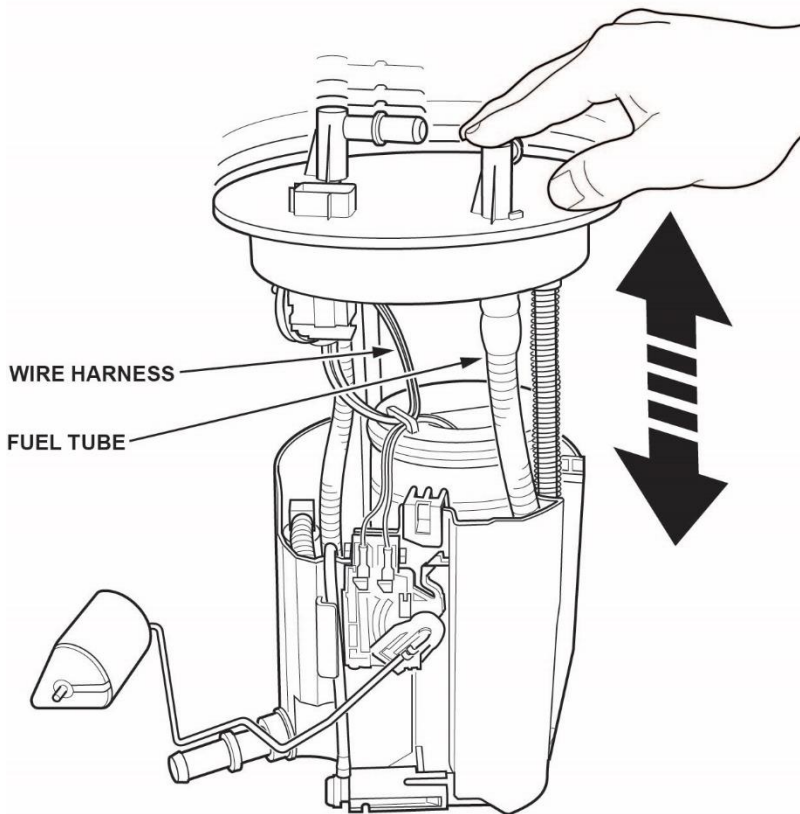

34. Clean the seal surfaces on the fuel tank unit and gasket groove on the fuel tank.

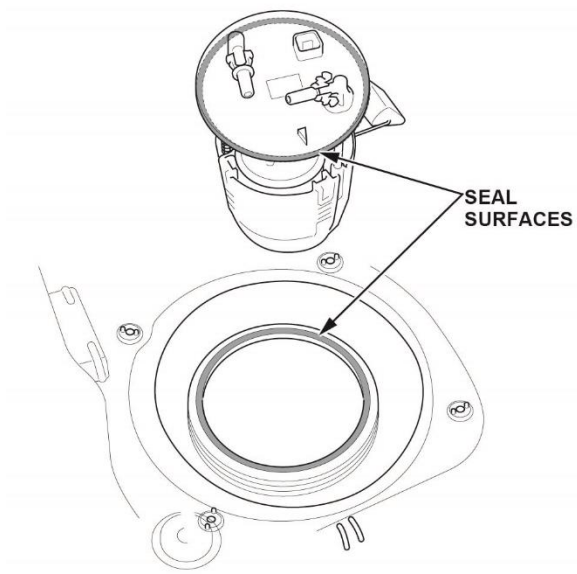

35. Carefully install a new base gasket to the gasket groove on the fuel tank as shown.



36. Connect the transfer tube to the fuel tank unit.

NOTE: Make sure the transfer tube clamp is positioned as shown.

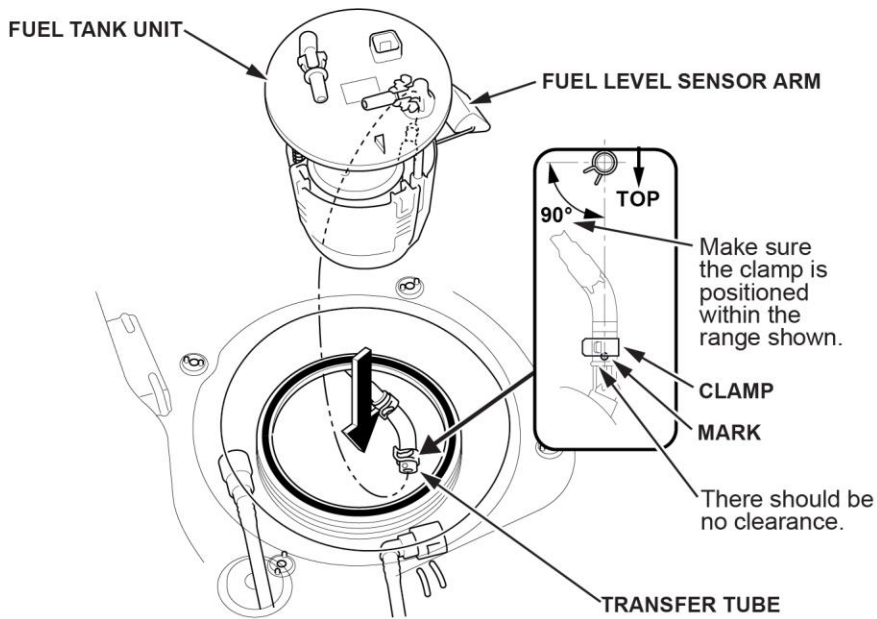

37. Line up the mark on the fuel tank unit to the marks on the fuel tank, then insert the fuel tank unit into the fuel tank.

NOTE: To avoid any leaks, check the O-ring, either visually or by hand, to make sure it is not pinched.

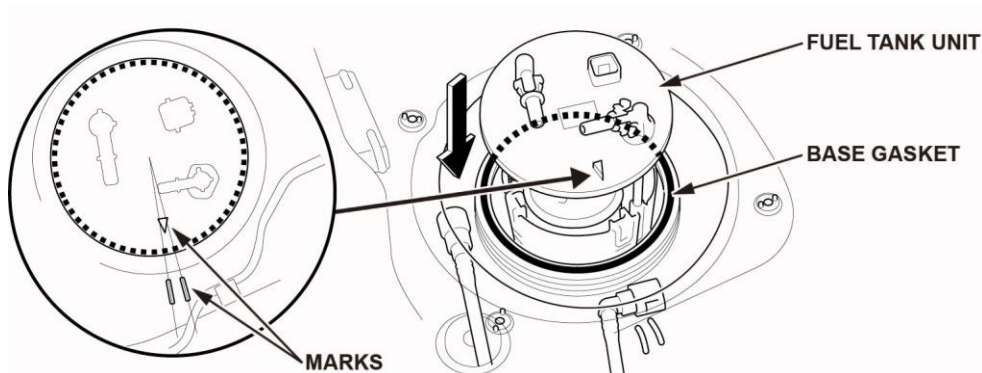

38. While pushing down on the fuel tank unit, make sure the fuel tank unit is flat against the base gasket. To avoid a leak and/or damaging the gasket, make sure the gasket is not pinched. Do this either visually and/or by hand.

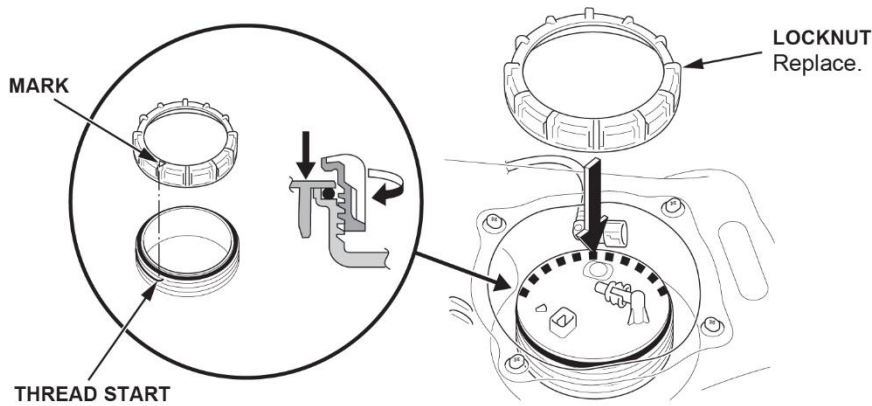

39. Line up the mark on the new locknut to the start of the thread on the fuel tank.

40. Push down firmly on the locknut at the 3 o'clock mark to make sure the threads on the fuel tank opening are properly engaged.

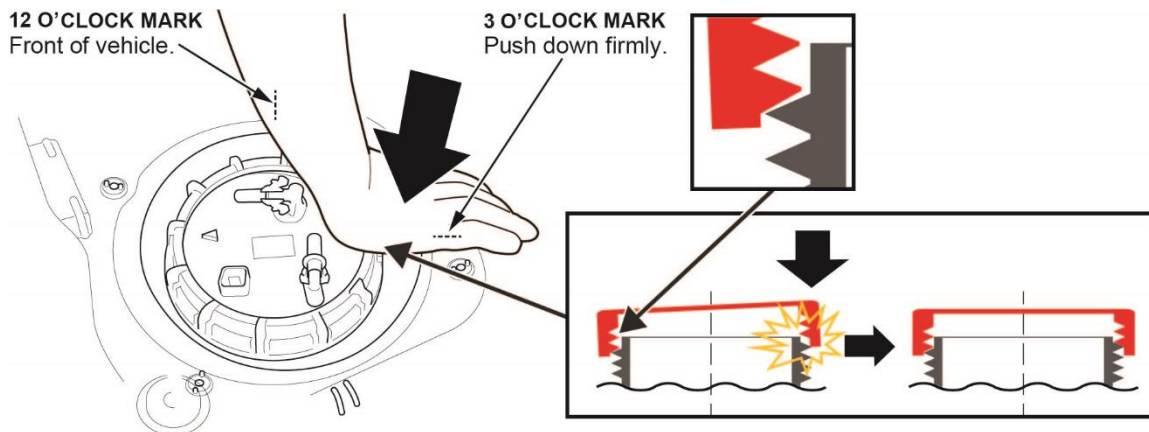

41. Rotate the locknut clockwise 195 degrees from the thread starting point.

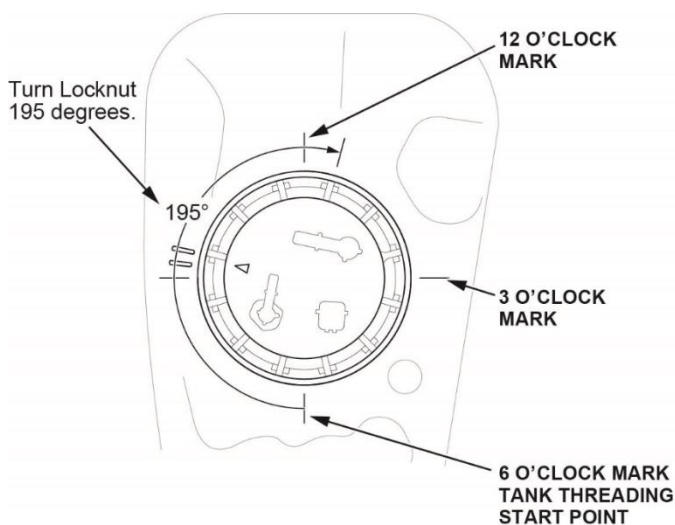

42. To keep the fuel tank unit parallel to the opening in the fuel tank, push down at the 3 o'clock mark while turning the locknut clockwise by hand.

NOTE: During installation, check the O-ring, either visually or by hand, to make sure it is not pinched.

43. Using the fuel nut wrench, tighten the locknut to **100 N·m (74 lb-ft)**.

NOTE: After tightening, make sure the mark on the fuel tank unit is still lined up with the marks on the fuel tank.

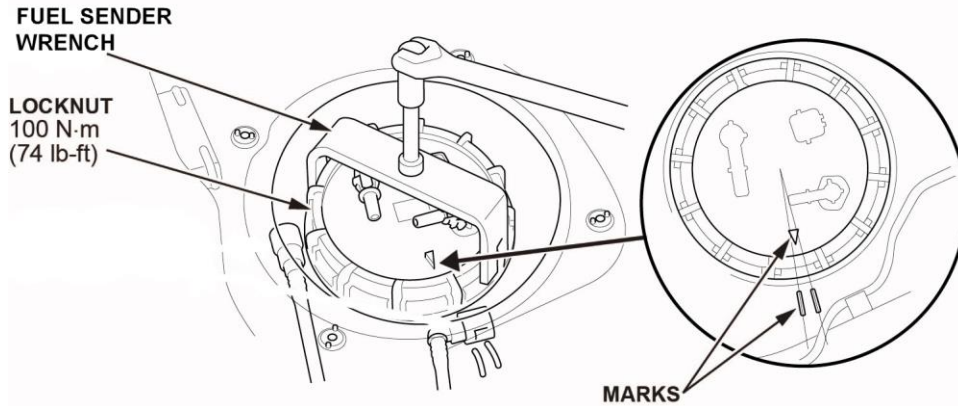

44. *If the marks do not line up*, friction between the fuel tank unit and the locknut may cause the fuel tank unit to turn while tightening. Observe the difference (shaded area), and loosen the locknut until the fuel tank unit can be rotated. Rotate the fuel tank unit **counter-clockwise** by the same amount, and repeat the tightening process.

NOTE: Repeat this step as necessary until the marks are lined up when the locknut is tightened to the specified torque.

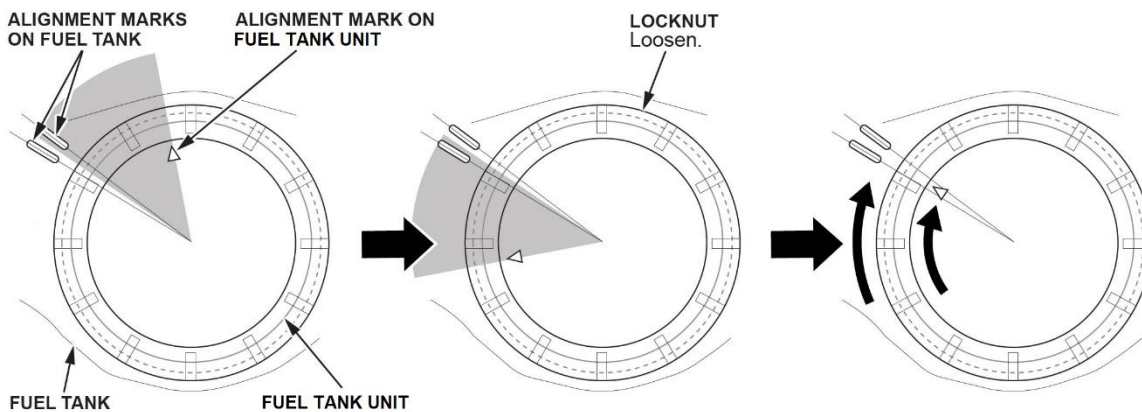

45. Remove the quick-connect fitting retainers from the fuel tank unit, then install the new retainers onto the quick-connect fittings as shown.

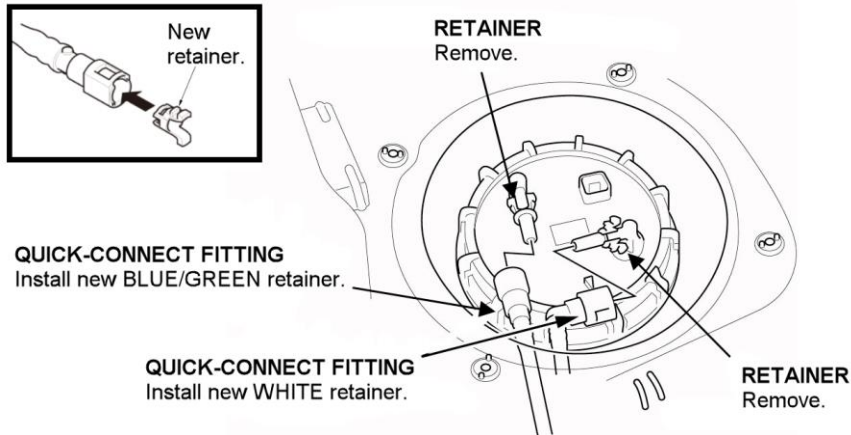

46. Connect the fuel line quick-connect fittings to the fuel tank unit.

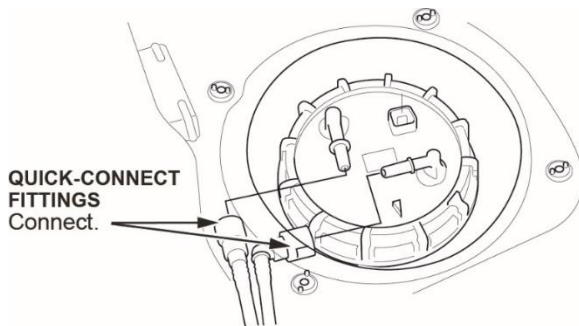

47. Connect the fuel tank unit connector.

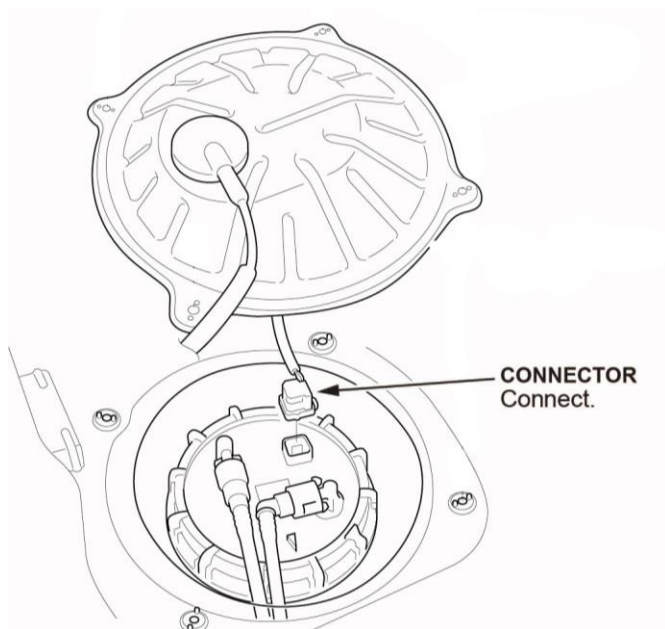

48. Connect the 12-volt battery terminals.

49. Turn the ignition to ON, but do not turn the engine on. After the fuel pump runs for about **2 seconds**, the fuel line will be pressurized. Repeat this two or three times, then make sure there is no fuel leakage.
50. Install the fuel tank unit access panel.
51. Install the remaining parts in the reverse order of removal.
52. Clear all DTCs using an i-HDS.
53. *California residents only:* Fill out a Vehicle Emissions Recall – Proof of Correction certificate, and use **WAC** as the recall number. Have the service advisor give the certificate to your customer, and advise him or her to keep it as proof that the recall was completed. Your customer will need to submit this certificate to the DMV only if the DMV requests it. If you need more certificates, use reorder number **Y0657**.

Vehicle Emission Recall - Proof of Correction				
License Number	Make	Year Model	Body Type	Vehicle Identification Number <div style="border: 1px solid black; display: flex; justify-content: space-between; padding: 2px;"> 1234567891011121314151617181920 </div>
Manufacturer _____			Recall Number WAC	
<p style="font-size: small;">The above described vehicle has been repaired, modified and/or equipped with new emission control devices to meet applicable California Emission Control Laws.</p>				
Dealer's Name _____		Address, City, State and Zip _____		
Date _____	Dealership's Authorized Signature _____			
X				
Return this certificate to DMV only when required - otherwise retain for your records.				

Y0657 ACL 24832 (0212)

END