

ATTENTION:

- GENERAL MANAGER
- PARTS MANAGER
- CLAIMS PERSONNEL
- SERVICE MANAGER

IMPORTANT - All Service Personnel Should Read and Initial in the boxes provided, right.

© 2022 Subaru of America, Inc. All rights reserved.



QUALITY DRIVEN® SERVICE

PRODUCT CAMPAIGN BULLETIN

APPLICABILITY: 2015-2021 MY WRX STI

NUMBER: WRE-22

SUBJECT: Safety Recall – Back-Up Lamp Switch Failure

DATE: 09/02/22

NHTSA: 22V-522

Subaru of America, Inc. (Subaru) is initiating a new safety recall for certain 2015-2021 model year WRX STI vehicles, which may contain a defective back-up lamp switch.

DESCRIPTION OF THE DEFECT AND SAFETY RISK

The operating environment of the back-up lamp switch may expose the internal switch contacts to heated oil. When heated, sulfur in the oil may cause a chemical reaction with the materials used on the switch terminal contact surfaces and plate spring. This chemical reaction may cause corrosion and a non-conductive film to form on the contacts resulting in poor electrical conductivity.

Over time, the back-up lamp switch may become inoperative which may result in the back-up lamps not illuminating when in reverse gear, the rear-view camera (if equipped) not displaying an image, and the select lever/gear position indicator in the combination meter not displaying ‘R’ for reverse gear.

If the back-up lamps do not illuminate when the vehicle is in reverse gear, this may reduce the awareness of other motorists or road users of the driver’s intention to operate the vehicle in reverse, increasing the risk of a crash. Additionally, a rear-view camera (if equipped) that does not display an image can reduce the driver’s view of what is behind the vehicle, increasing the risk of a crash.

REMEDY

For all potentially affected vehicles, Subaru retailers will conduct an inspection and replace the back-up lamp switch with improved one, if necessary, at no cost to the customer.

AFFECTED VEHICLES

A total of 59,934 U.S. WRX STI vehicles will be affected by this recall, as listed below:

Model Year	Carline	Production Date Range
2015-2021	WRX STI	November 14, 2013 – October 21, 2021

Not all vehicles in the production range listed above are affected by this recall. Coverage must be confirmed by using the Vehicle Coverage Inquiry function on subarunet.com prior to repair.

CAUTION: VEHICLE SERVICING PERFORMED BY UNTRAINED PERSONS COULD RESULT IN SERIOUS INJURY TO THOSE PERSONS OR TO OTHERS.

Subaru Service Bulletins are intended for use by professional technicians ONLY. They are written to inform those technicians of conditions that may occur in some vehicles, or to provide information that could assist in the proper servicing of the vehicle. Properly trained technicians have the equipment, tools, safety instructions, and know-how to do the job correctly and safely. If a condition is described, DO NOT assume that this Service Bulletin applies to your vehicle, or that your vehicle will have that condition.

Subaru of America, Inc. is ISO 14001 Compliant

ISO 14001 is the international standard for excellence in Environmental Management Systems. Please recycle or dispose of automotive products in a manner that is friendly to our environment and in accordance with all local, state and federal laws and regulations.

Continued...

RETAILER RESPONSIBILITY

Any vehicles listed in any recall/campaign that are in retailer stock must be:

- Immediately identified
- Tagged or otherwise marked to prevent their delivery or use prior to repair
- Repaired in accordance with the repair procedures outlined in the Product Campaign Bulletin

Retailers are to promptly perform the applicable service procedures, to correct all affected vehicles in their inventory (used, demo & SSLP). Whenever a vehicle subject to this recall is taken into retailer inventory necessary steps should be taken to ensure the recall correction has been made before selling or releasing the vehicle.

OWNER NOTIFICATION

Subaru will notify affected vehicle owners by first class mail on September 16, 2022.



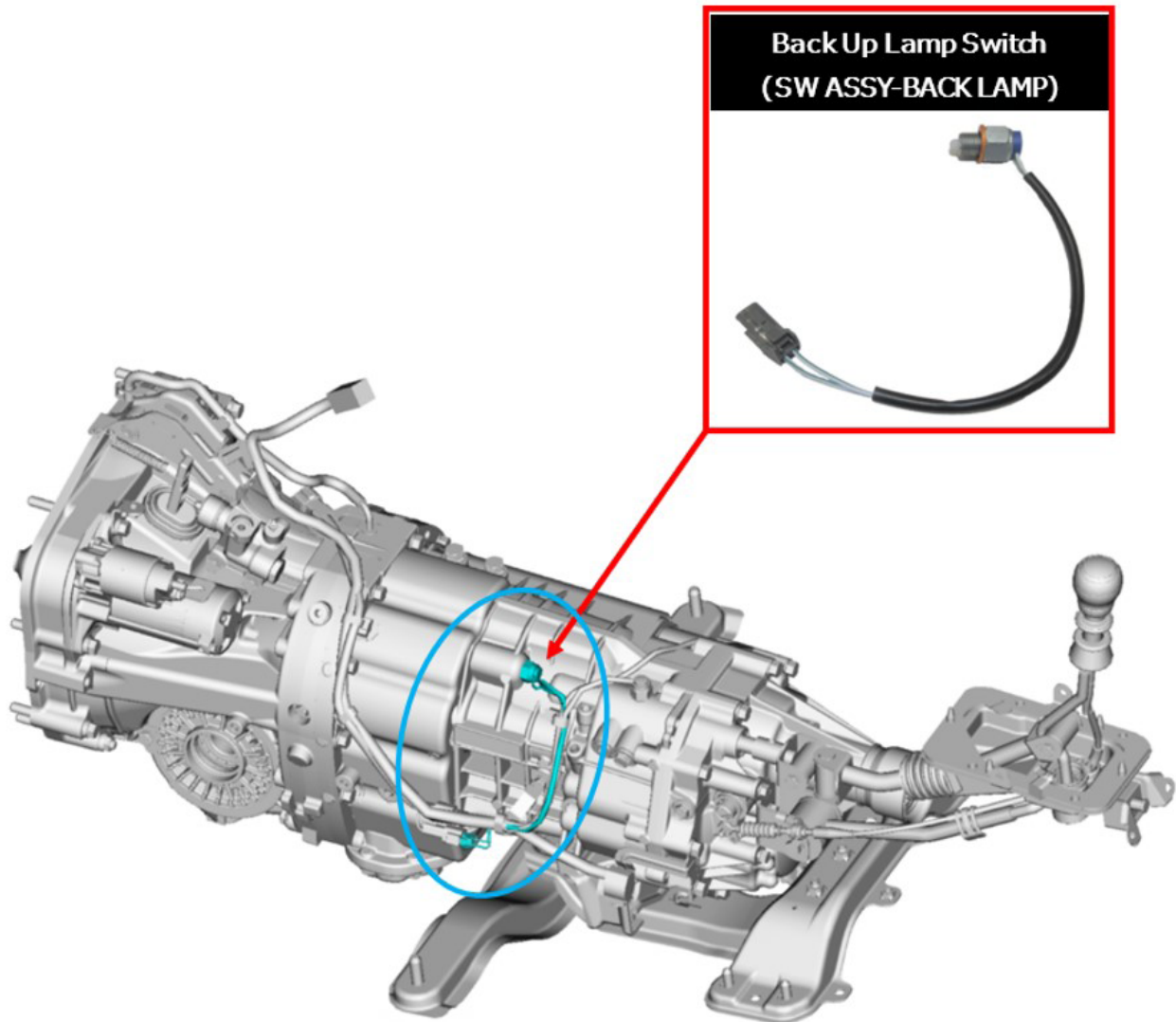







COMPONENT DESCRIPTION:

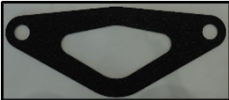

Continued...

PART INFORMATION:

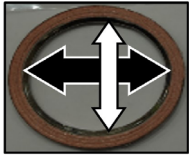
IMPORTANT: BACK-UP LAMP SWITCH KIT A (p.n. X3200AA220) and BACK-UP SWITCH KIT B (p.n. X3200AA330) MUST be ordered through PRIME.

2015 MY- 2018 MY except 2018MY Type RA				
Part Description	Part Number	Qty	Identification Label	
BACK LAMP SW KIT A	X3200AA220	1		
KIT Component Breakdown				
	Part Description	Part Number	Qty	Details
(1)	SW ASSY-BACK LAMP (Back lamp switch)	32005AA1139R	1	 Gasket is in the Package
(2)	GSKT-INTER COOLER	21896AA0729R	1	
(3)	GASKET(CR)	44022AA1239R	1	
(4)	SPRING PIN UN,G/S	6330460209R	1	
(5)	SELF LOCK NUT M10	9023300119R	4	
(6)	NUT FLG M8	9023800159R	6	
(7)	GSKT	44011AG0019R	1	
(8)	GASKET	44011SG0109R	2	  Major axis: 45.7 mm  Minor axis: 41.7 mm

Continued...

North America: 2019 MY - 2021 MY and 2018MY Type RA

Part Description	Part Number	Qty	Identification Label
BACK LAMP SW KIT B	X3200AA330	1	



KIT Component Breakdown



	Part Description	Part Number	Qty	Details	
(1)	SW ASSY-BACK LAMP (Back lamp switch)	32005AA1139R	1		Gasket Included
(2)	GSKT-INTER COOLER	21896AA0729R	1		
(3)	GASKET(CR)	44022AA1239R	1		
(4)	SPRING PIN UN,G/S	6330460209R	1		
(5)	SELF LOCK NUT M10	9023300119R	4		See Additional Note
(6)	NUT FLG M8	9023800159R	6		
(7)	GSKT	44011AG0019R	1		
(8)	GASKET	44011SG0009R	2		Major axis: 53.8 mm Minor axis: 49.8 mm
(9)	SELF LOCK NUT	0235080009R	12		STI draw Stiffener fixing nut Discard if these are not used.

Continued...

ADDITIONAL PARTS NOTES:

IMPORTANT: (5) SELF LOCK NUT M10 (p.n. 9023300119R) and (6) NUT FLG M8 (p.n. 9023800159R) supplied in the kit may be different from the nuts installed in the affected vehicle. These parts are interchangeable and can be used for this recall work.

(5) SELF LOCK NUT M10			
Part Application	Part Number	Details	
Replacement Part	9023300119R		Nut is exclusive for this recall
Vehicles Produced up to April 2016	902350001		Original installation nut & normal repair part
Vehicles Produced After April 2016	902330011		

(6) NUT FLG M8			
Part Application	Part Number	Details	
Replacement Part	9023800159R	 No Crimping	Nut is exclusive for this recall
Vehicles Produced up to July 2014	902350028	 Crimping	Original installation nut & normal repair part
Vehicles Produced After July 2014	902380015	 No Crimping	

Required Tools:

A Pin Punch with an 8mm Diameter and recommended length of 200mm or more. This is used for the removal and installation of the shift rod locking spring.

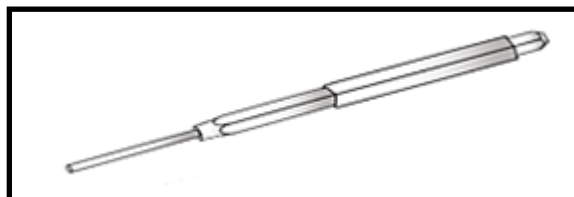

Continued...

IMPORTANT: The following tools framed in **BLUE** will be included in WRE-22 Tool Kit (p.n. SOA635173). This kit will be shipped to all retailers.

The Extended Universal Socket (p.n. 18270AA090) is used for removing and installing the back-up lamp switch.



The Extension Cap (p.n. 18678AA010) is used to prevent any unwanted oil loss during work procedures.

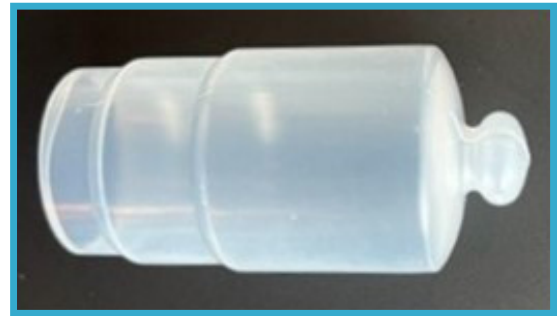

The **Green** Clip Pin D8.5X10 (p.n. 909130096) is used for positioning the shift rod and shift lever are when installing the locking spring.



Component Details:

The configuration images below outline the part application, part numbers, and torque information of the components involved when performing this work procedure. A **black star (★)** in the component breakdown illustrations is used to indicate one-time use parts.

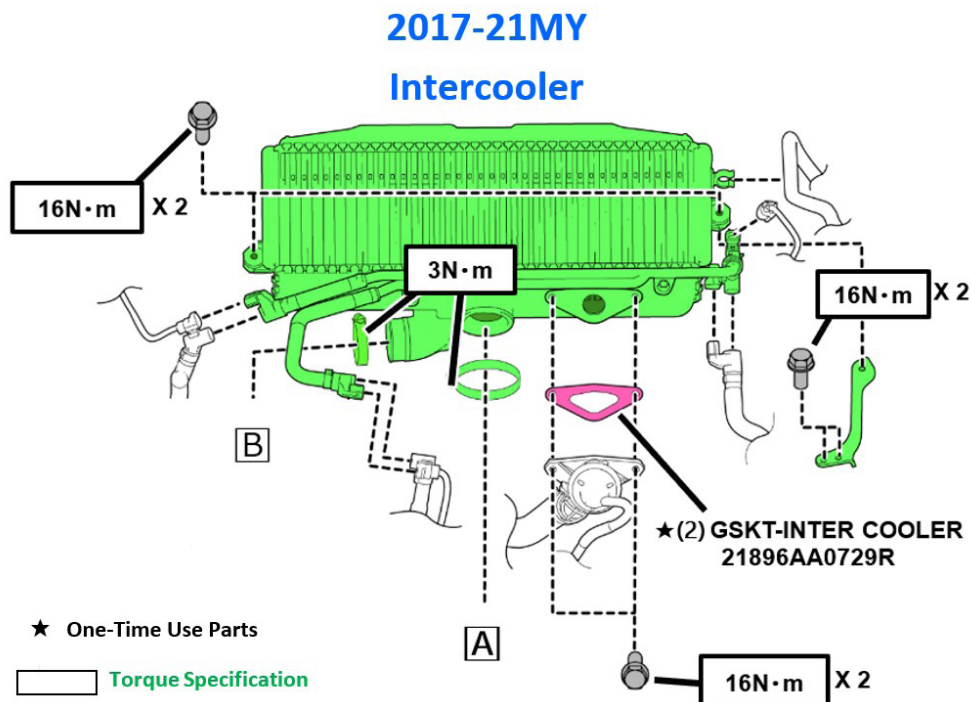

Continued...

2015-16MY Intercooler

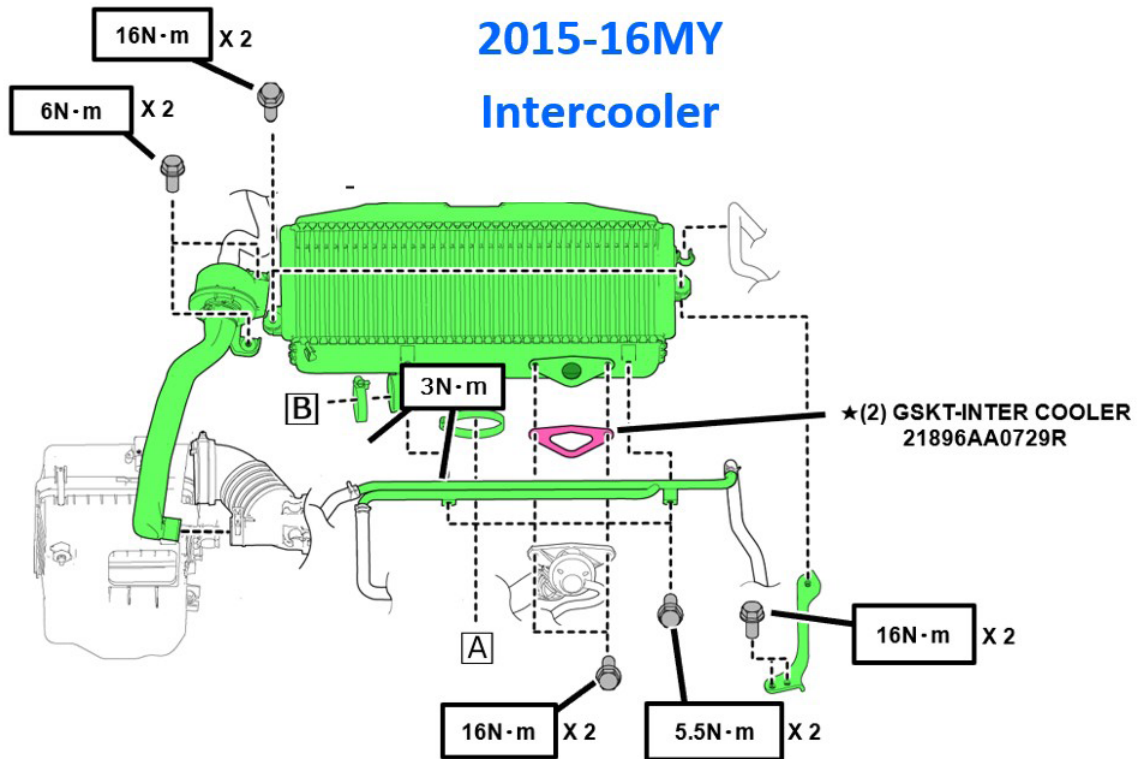

2015-21MY Engine Area

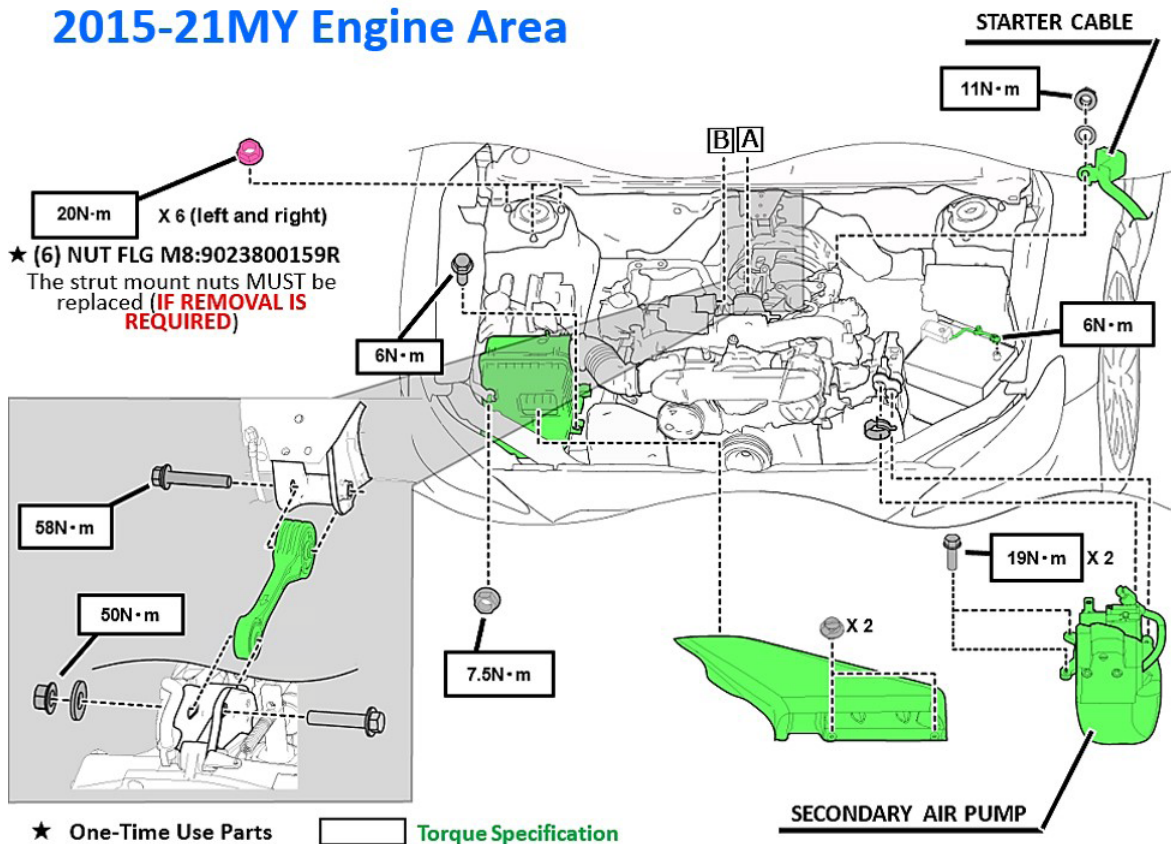

Continued...

2015-21MY Drive Shaft / Exhaust

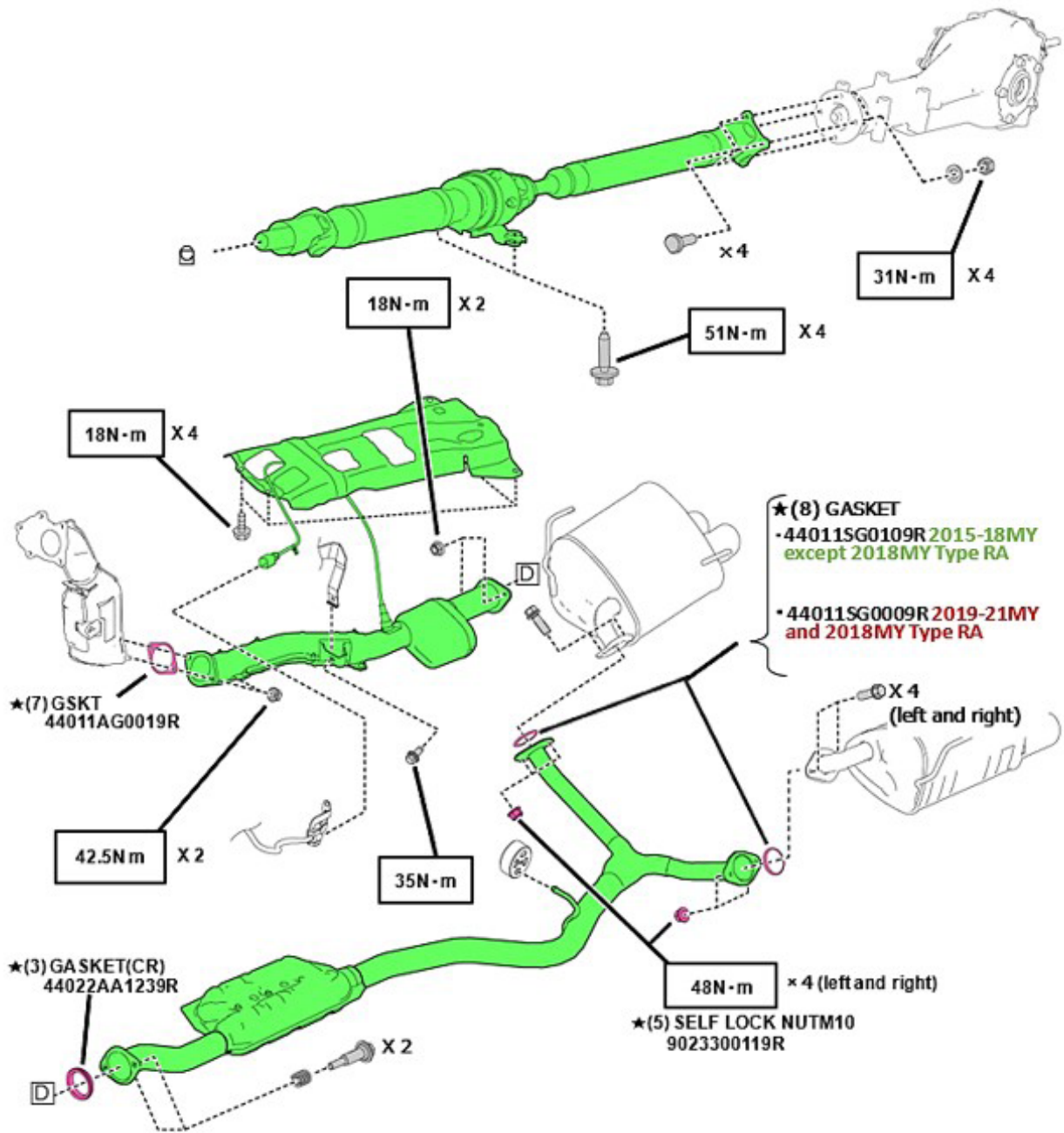

★ One-Time Use Parts

Torque Specification

Continued...

2015-21MY Manual Transmission

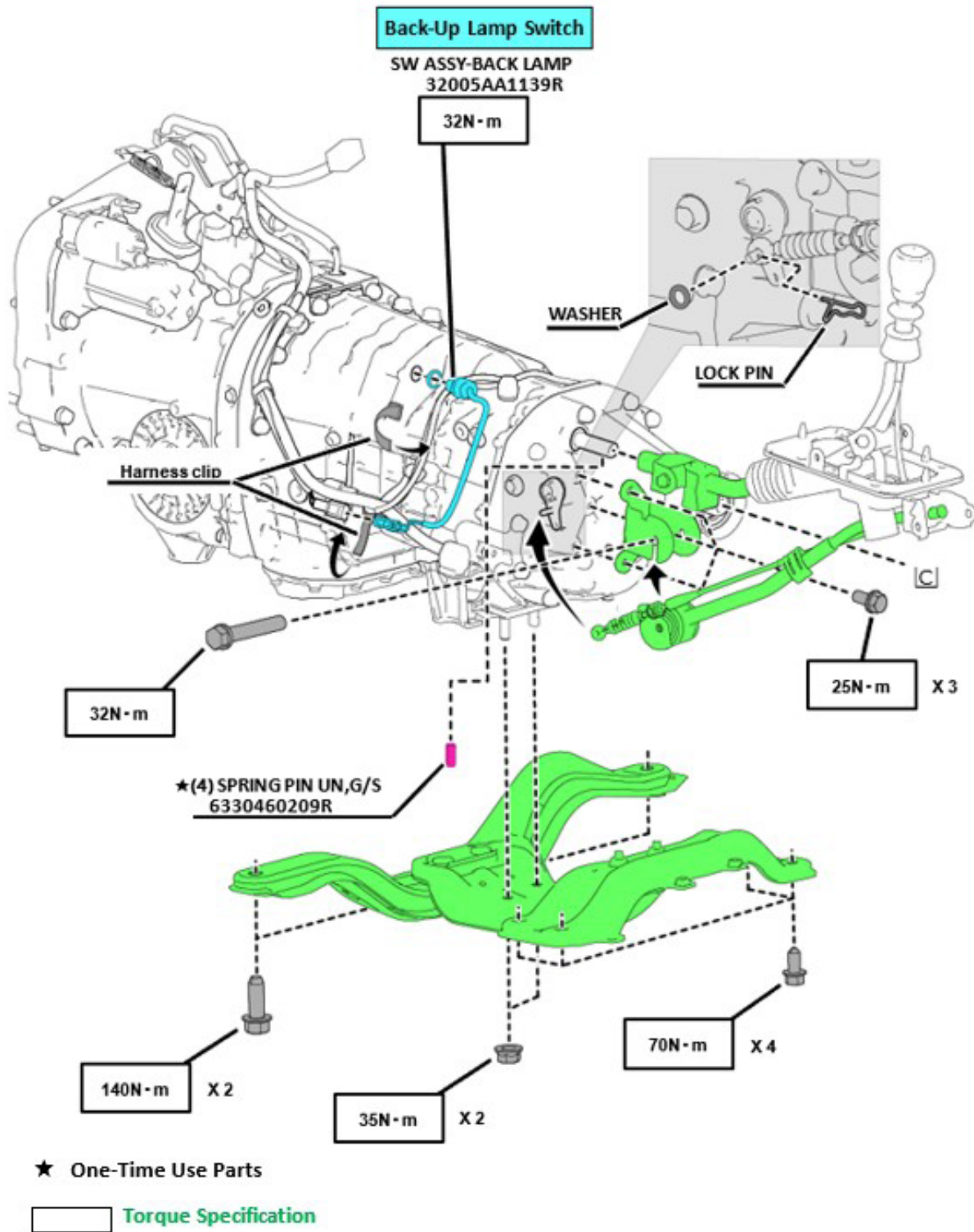

Continued...

Service Procedure Overview Flowchart:

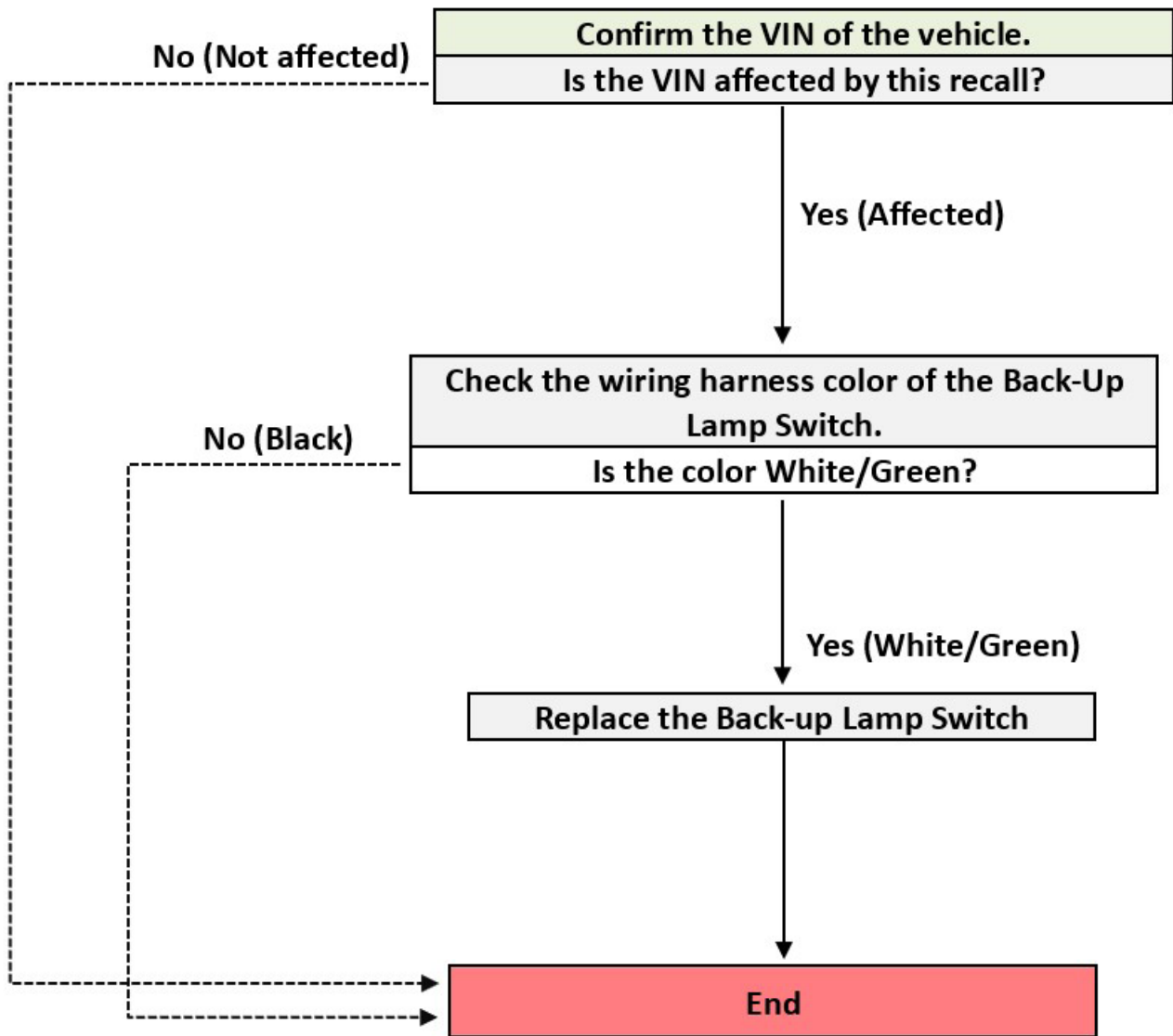

SERVICE PROCEDURE / INFORMATION:

STEP 1: Lift up the vehicle.

STEP 2: For 2019MY S209 model, remove the STI flexible draw stiffener. Refer to the [S209 Service Manual](#)

Continued...

STEP 3: Remove clip (A), the two bolts (B), the two clips (C) and clip (D). The lower transmission cover can then be removed.

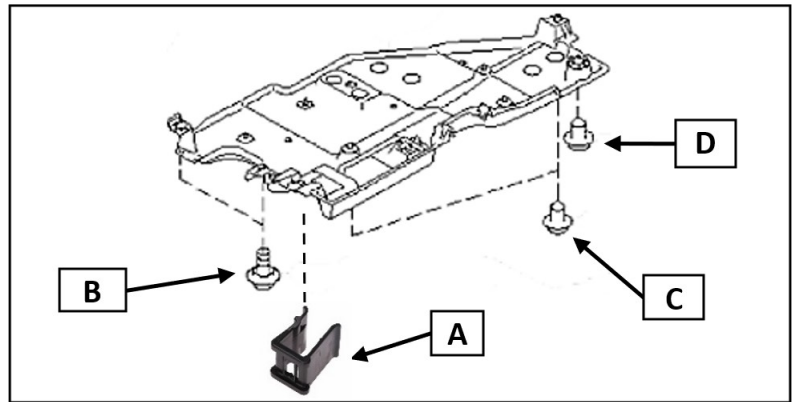

STEP 4: Perform a visual inspection of the wiring harness colors on the back-up lamp switch.

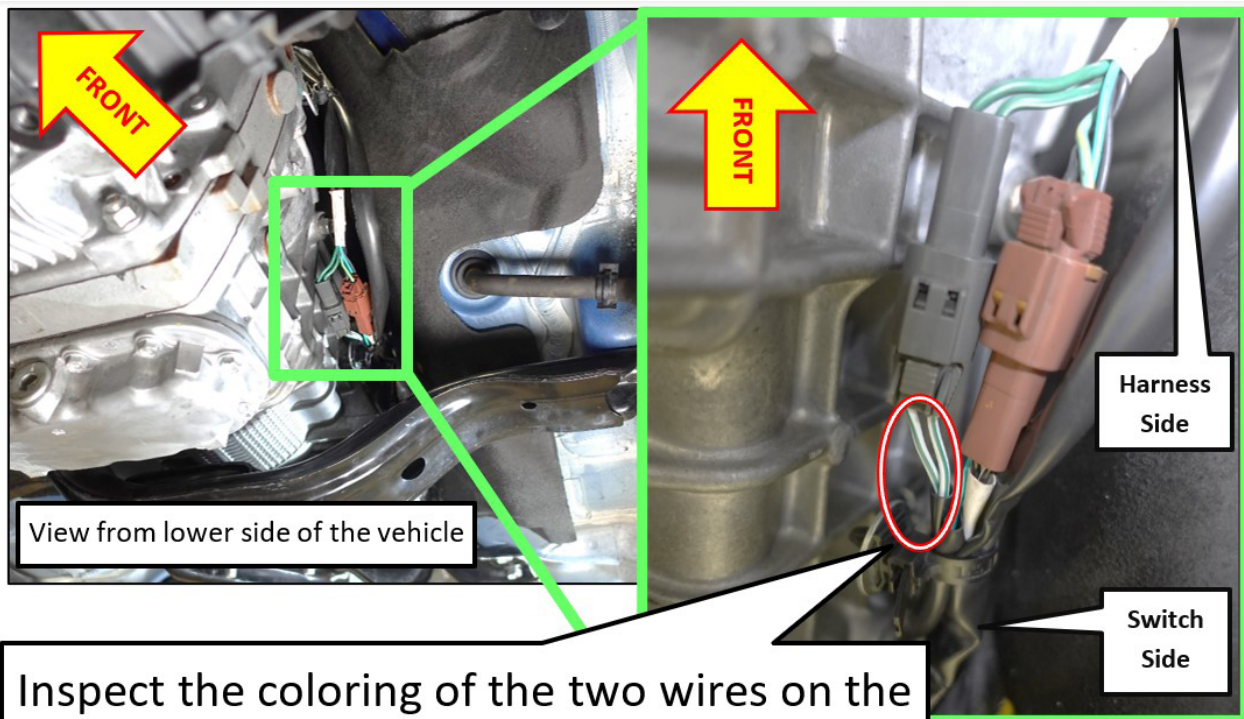



Inspect the coloring of the two wires on the switch side of the gray connector

The black protection tube can be pulled back for inspection

Continued...

STEP 5: Apply the visual inspection results from **STEP 4** to the table below to verify the next course of action.

Wiring Harness Color	WHITE/GREEN 	BLACK 
Back-Up Lamp Switch Version	OLD	NEW
Back-Up Lamp Switch Replacement	REQUIRED	<u>NOT</u> REQUIRED
Next Step	Proceed to STEP 6	No further action is required. Reinstall the removed parts in the reverse order of disassembly.

STEP 6: Refer to the applicable Service Manual and review: General Description > Repair Contents > Action required before & after Battery Disconnect. Additionally, record any stored seat position(s) before proceeding. Relearn any seat position memory after work is complete. Confirm that the shift lever is in the Neutral position. Confirm the parking brake is released. Depress the brake pedal several times to remove any pressure in the brake booster. **CAREFULLY** remove the ground terminal from the battery.

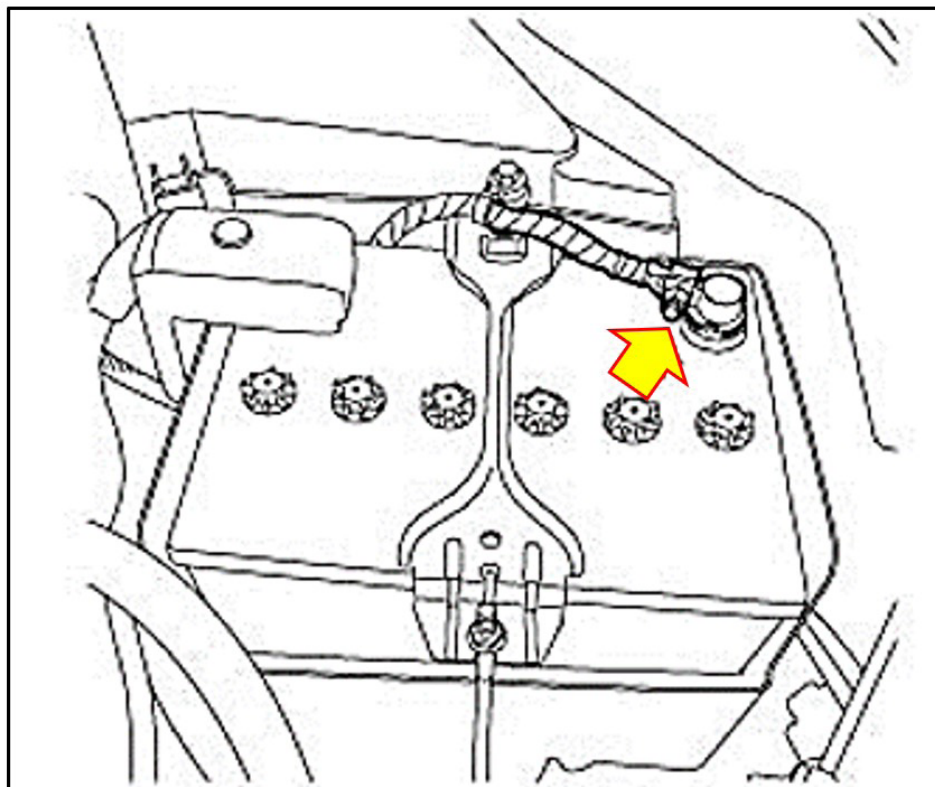

Continued...

STEP 7: Remove the intercooler in accordance with the applicable Service Manual.

NOTE: S209 models will require the removal of the STI Flexible Tower Bar. The strut mounting nuts are one-time use parts. Refer to the [S209 Service Manual](#).

CAUTION: Be mindful not to deform or damage the intercooler fins. Tape and cardboard can be used for added protection.



STEP 8: Remove the pitching stopper. Take note of the hardware positioning for reassembly. This will allow the transmission to be tilted in order to provide the necessary clearance for back-up lamp switch replacement.

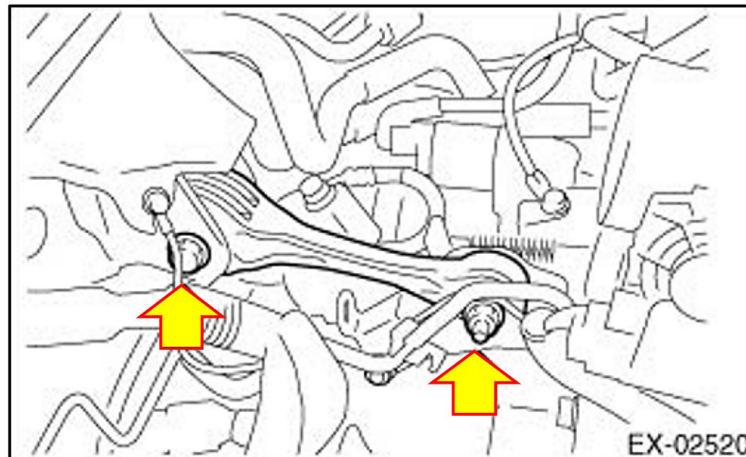

STEP 9: Remove the nut and lock washer at the starter B connection to the starter motor. This will eliminate any unwanted tension while tilting the transmission assembly.

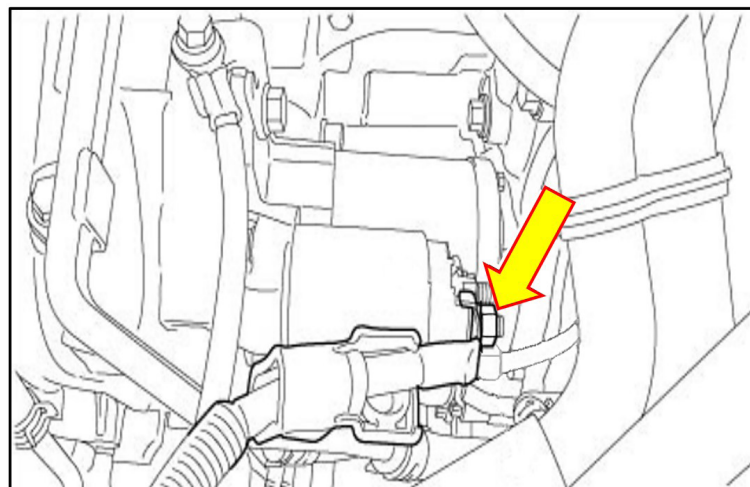

Continued...

STEP 10: Disconnect the two engine coolant hoses from the holding clamps. This will eliminate any unwanted tension during the tilting of the transmission assembly. The hoses do not require removal.

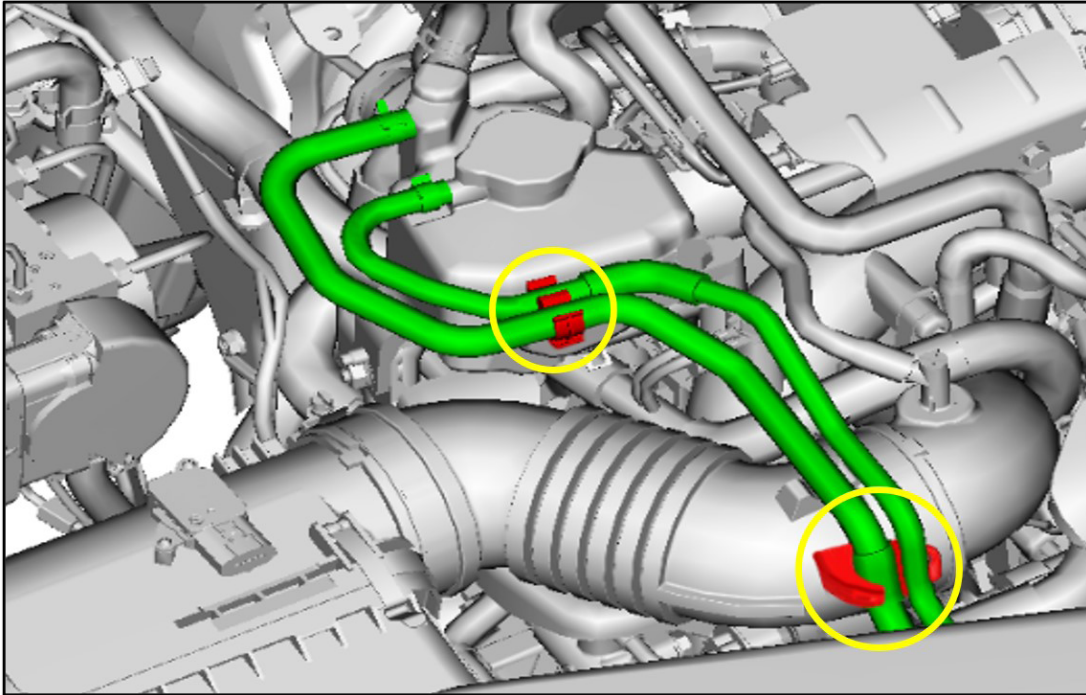

STEP 11: Remove the two clips retaining the air intake duct and removed the air intake duct. This will prevent the duct from interfering with the injector cover.

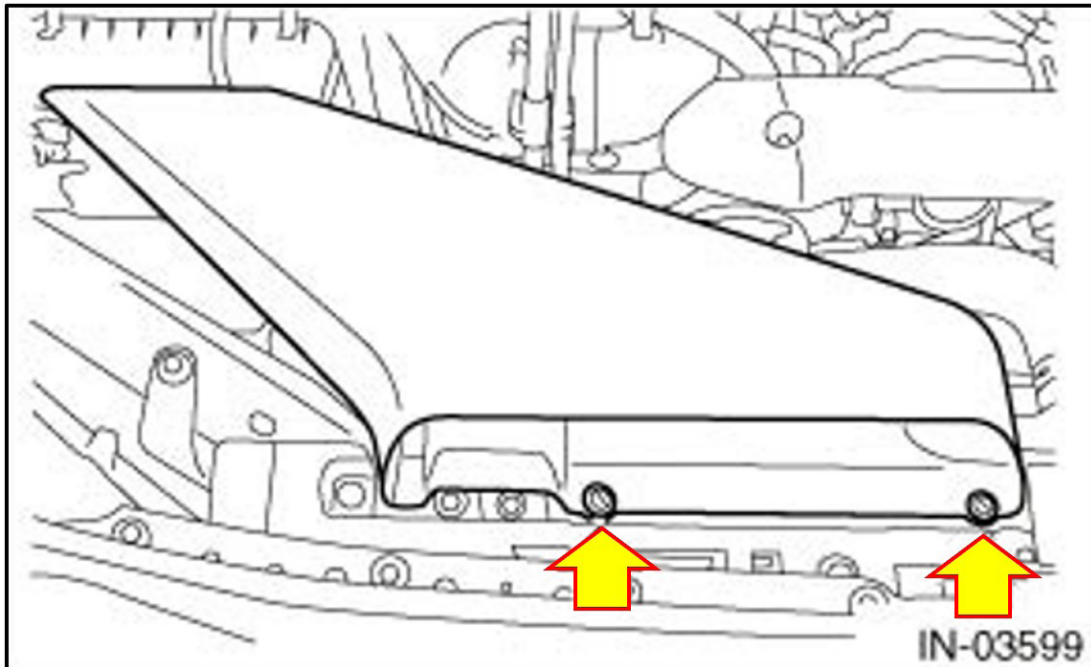

Continued...

STEP 12: Remove the two air cleaner case mounting bolts. Slightly move the case toward the rear of the vehicle so the mounting stud is clear. This will prevent any contact between the air conditioning hose and the secondary air pump.

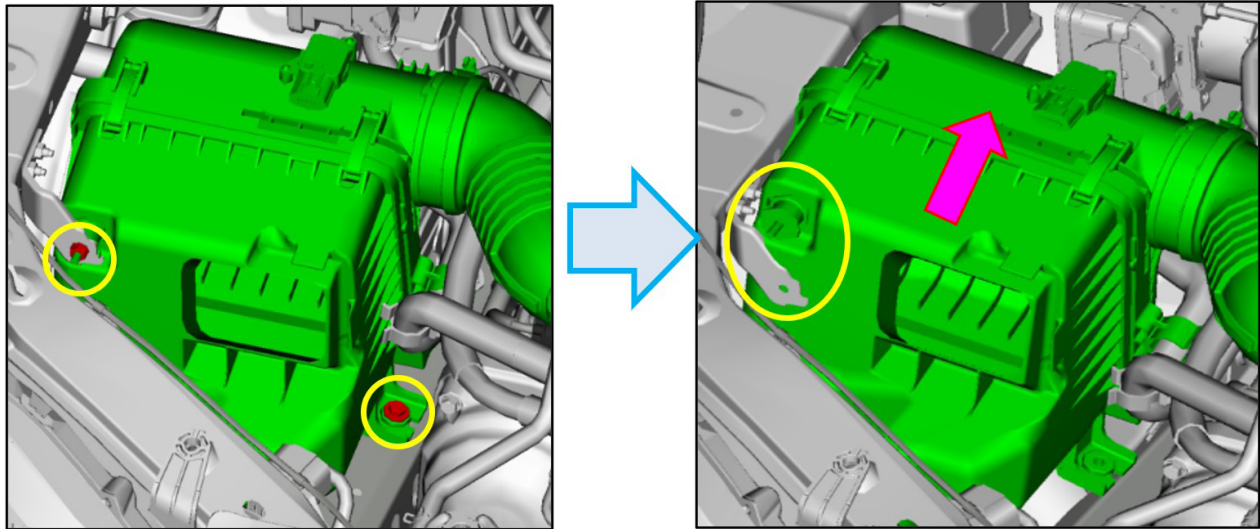

STEP 13: Remove the center exhaust pipe and the rear exhaust pipe. Refer to the applicable Service Manual: Engine > EXHAUST > Center Exhaust Pipe & Rear Exhaust Pipe

STEP 14: Remove the secondary air pump as per the applicable Subaru Service Manual: Engine > EMISSION CONTROL (AUX. EMISSION CONTROL DEVICES) (STI)

STEP 15: Remove the propeller shaft. Refer to the applicable Service Manual: Driveline/Axle > DRIVE SHAFT SYSTEM > Propeller Shaft

IMPORTANT: When the propeller shaft is removed, the supplied extension cap must be installed into the transmission to prevent any unwanted fluid loss. A small amount of gear oil can be used as an installation lubricant.

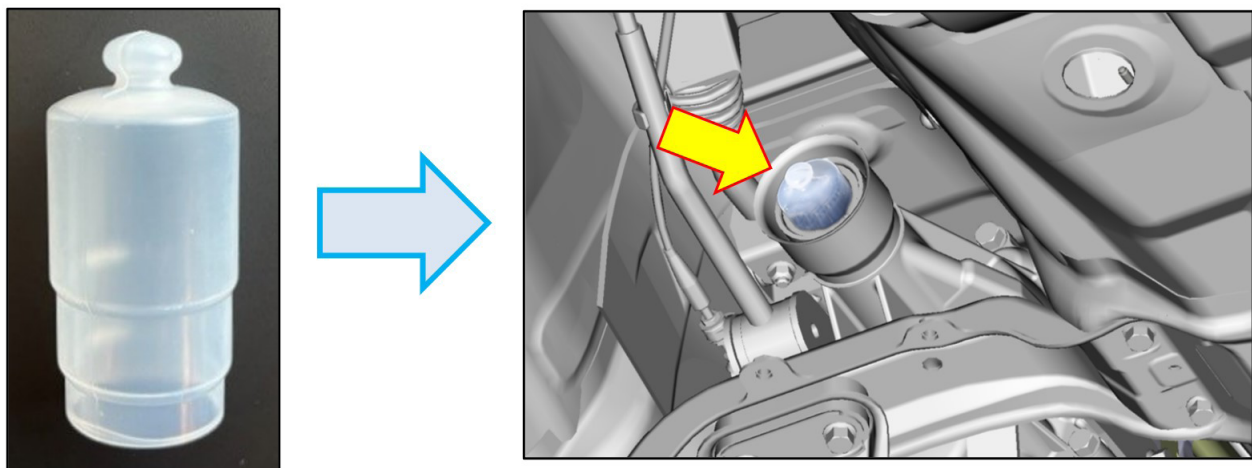

Continued...

STEP 16: Set the transmission jack in a position that will allow clearance for the crossmember removal.

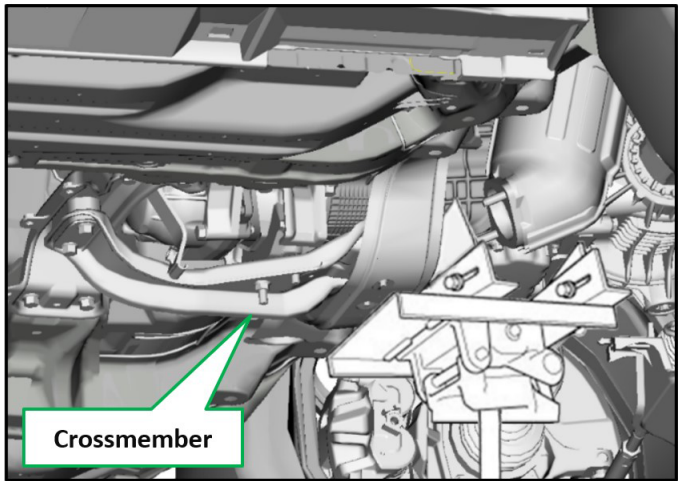

Remove the six mounting bolts and two mounting nuts. Remove the crossmember.

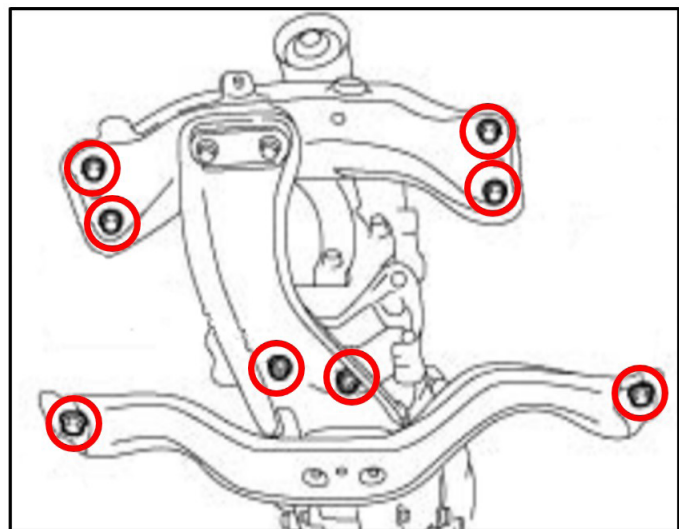

STEP 17: Remove the snap pin and washer from the reverse check cable. These parts will be reused and should be stored securely. Once removed, disconnect the cable from the reverse check lever.

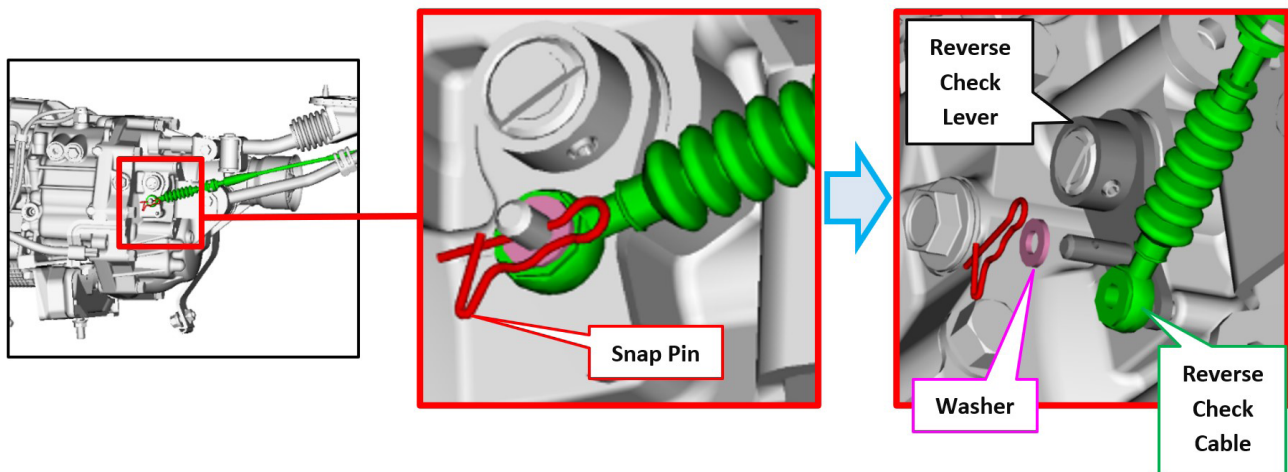

Continued...

STEP 18: Loosen the stay bolt. Remove the stay, stay bolt, and reverse check bracket by moving it in a downward direction away from the shift bracket.

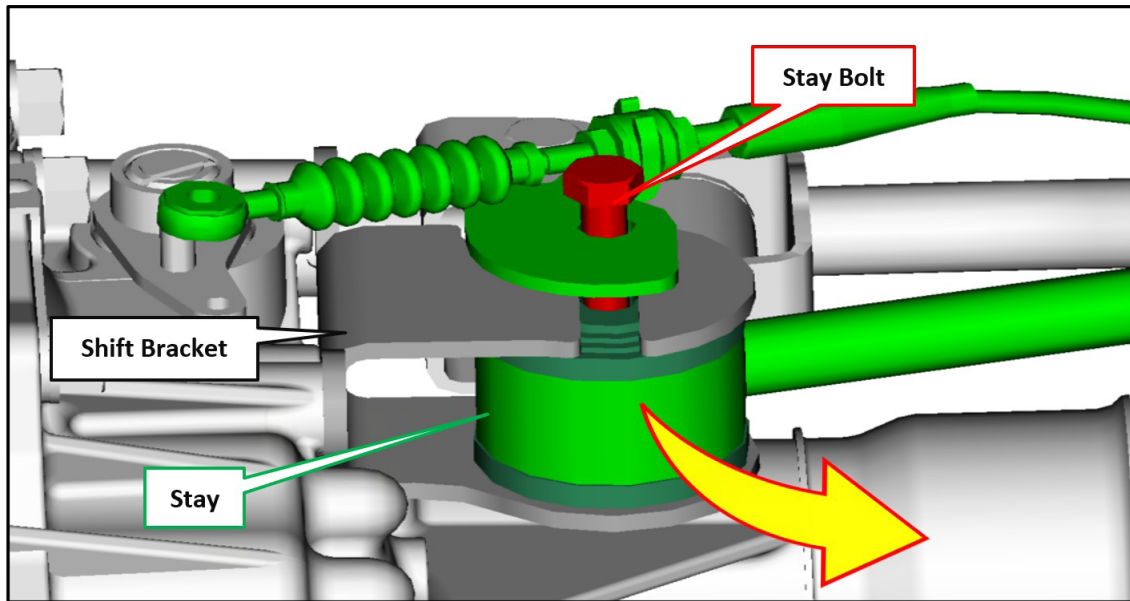

STEP 19: Remove the three bracket mounting bolts then remove the shift bracket.

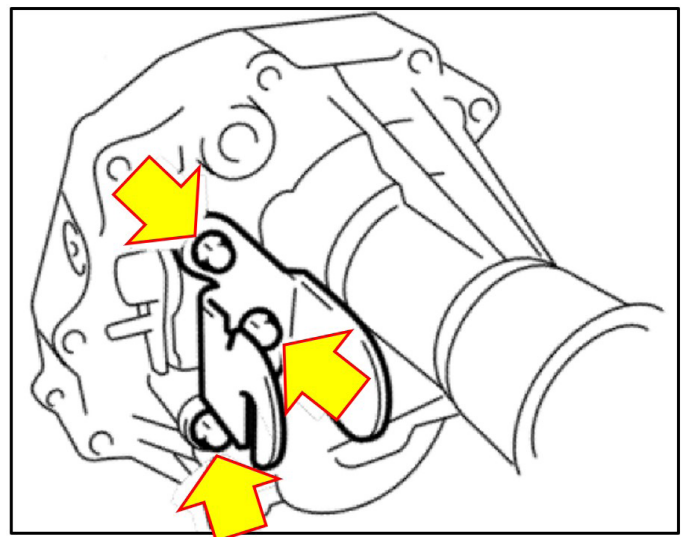

STEP 20: Position the shift rod in fourth gear (towards the rear of the vehicle). This will be the optimum position for removal of the spring pin.

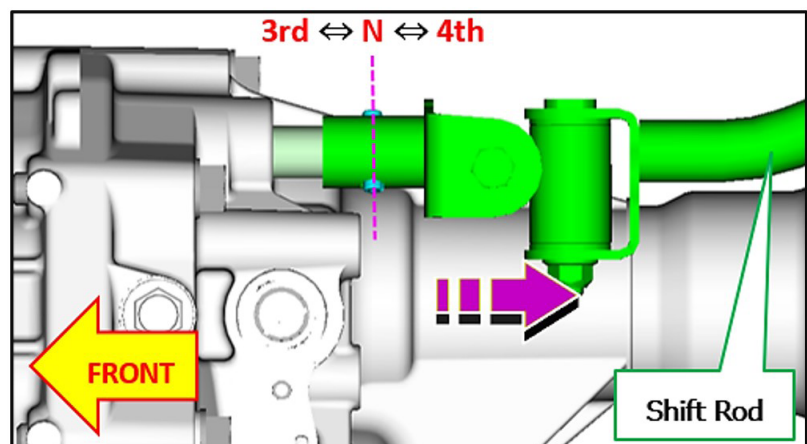

Continued...

STEP 21: Using a punch with a diameter of 8mm and a length of at least 8 inches (200mm), drive out the spring pin.

CAUTION: Take particular care to not hit or damage the surrounding areas while performing.

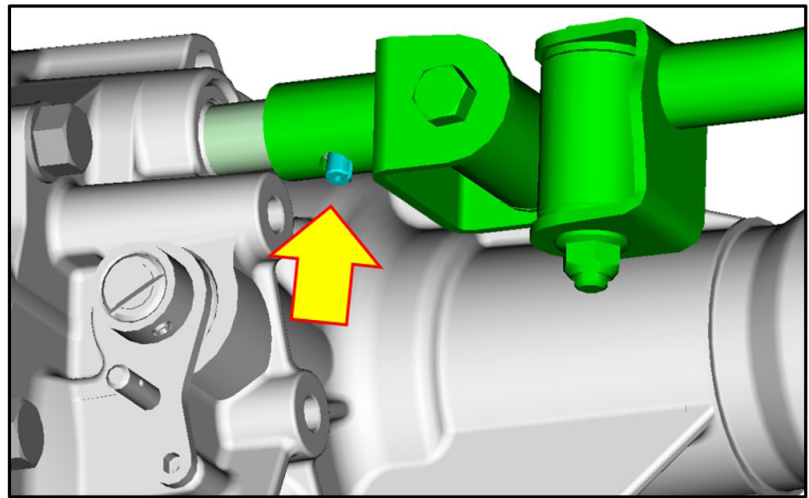

STEP 22: Once the spring pin is removed, the shift rod can then be positioned in the third gear (toward the front of the vehicle).

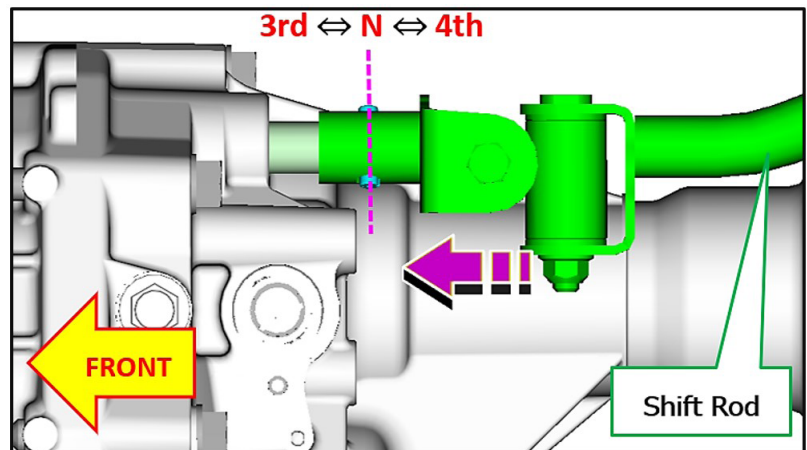

STEP 23: Separate the shift rod from the shifter arm shaft. Moving the shift rod in a twisting motion can make this process easier.

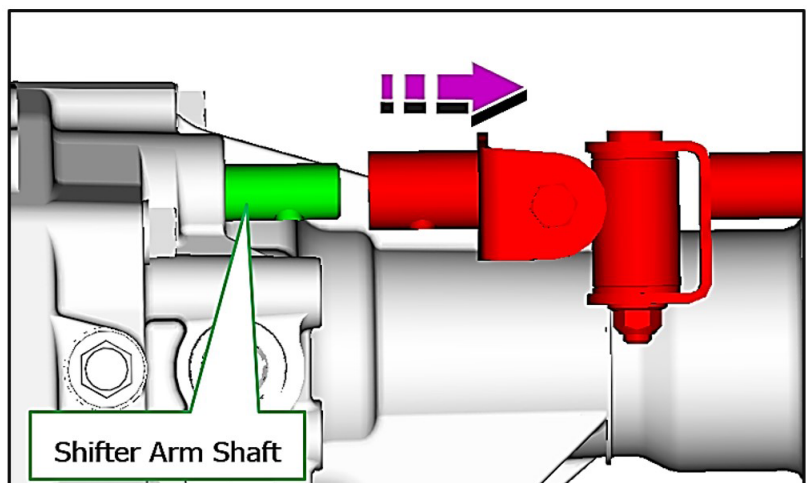

Continued...

STEP 24: Lower the transmission assembly approximately 6 inches (150mm) from the floor pan to the upper edge of the transmission output dust cover.

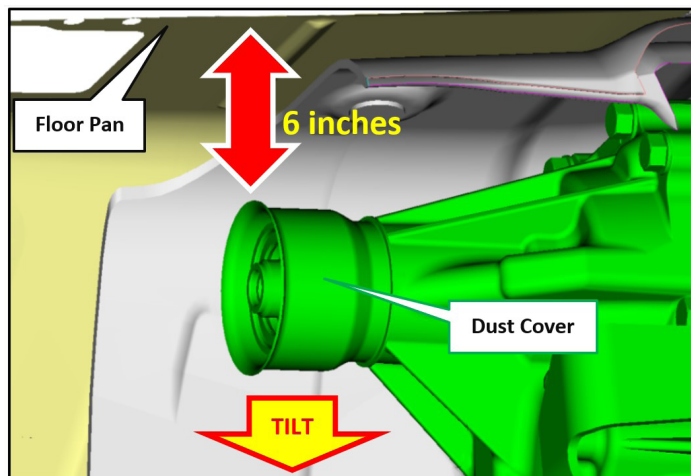

STEP 25: Release the retaining bands holding the back-up switch harness.

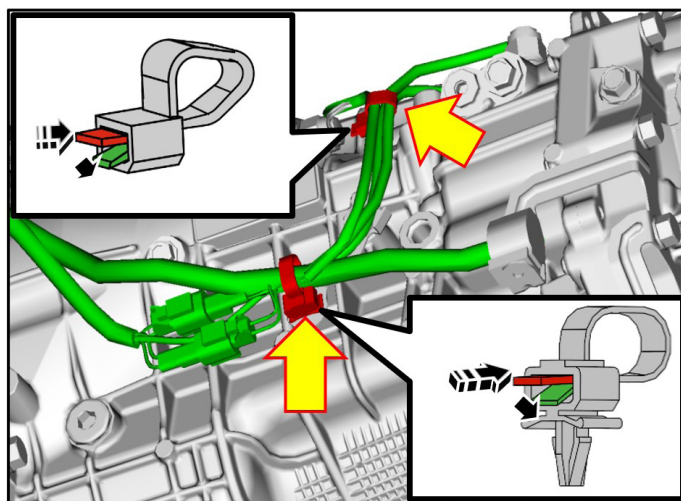

STEP 26: Disconnect the gray two-pin connector on the back-up switch harness.

STEP 27: Using compressed air, clear any debris from the back-up switch. This will help prevent any contamination.

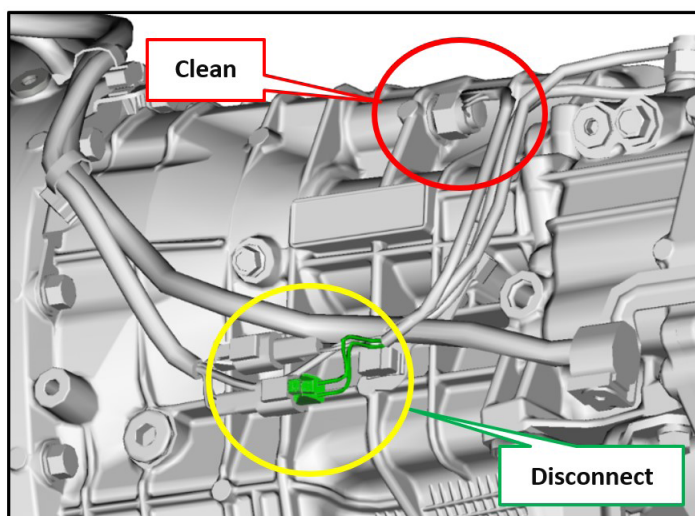

Continued...

STEP 28: Install the special tool (p.n. 18270AA090) onto the back-up switch with the wires aligned with the socket recess. Make sure the tool is passed under the switch harness. A suitable extension (approximately 8 inch) can be used in conjunction with the special tool.

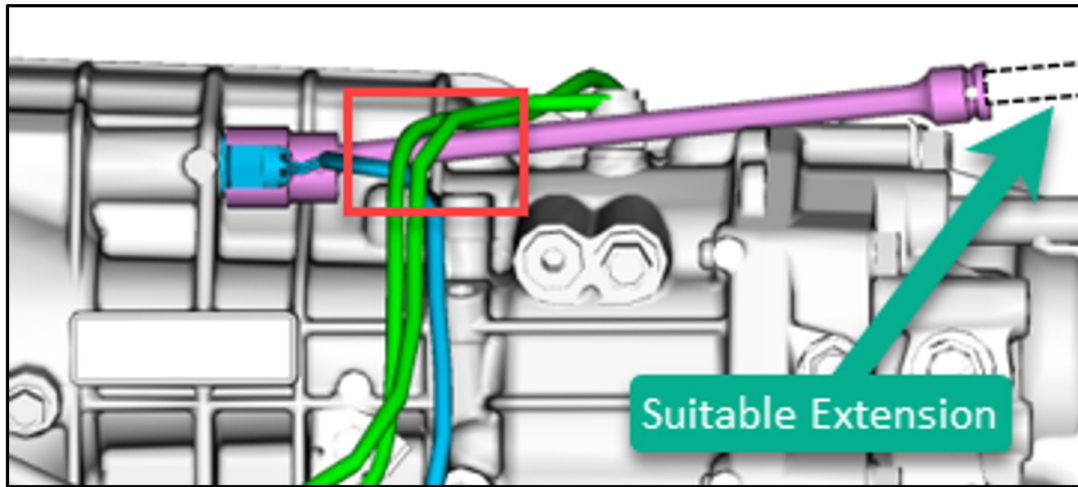

CAUTION: Confirm the socket is fully seated onto the back-up switch. Confirm the wires are not damaged by the socket.

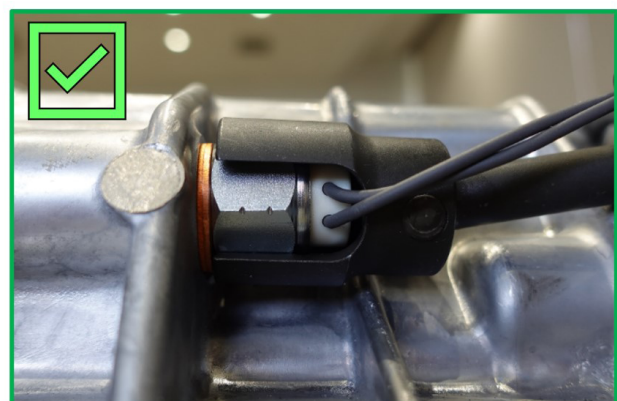
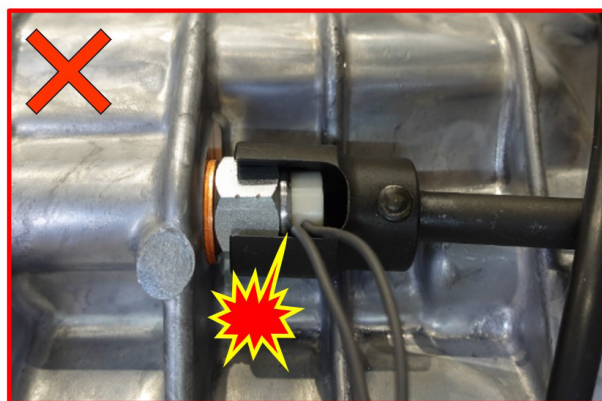
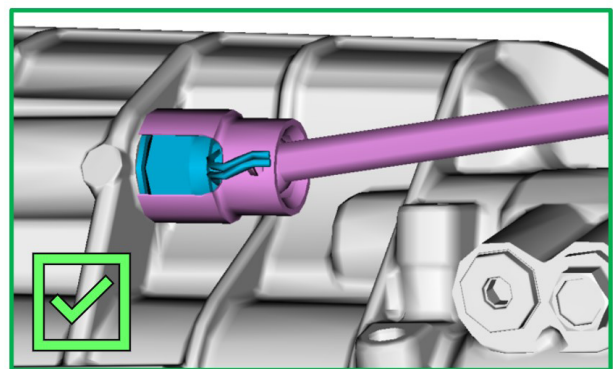
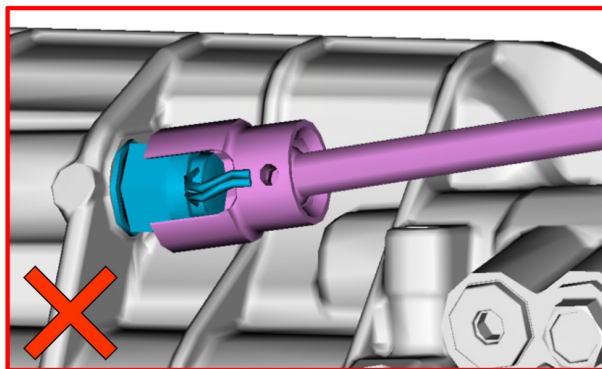

Continued...

CAUTION: Take particular care not to damage the neutral position switch with the special tool.

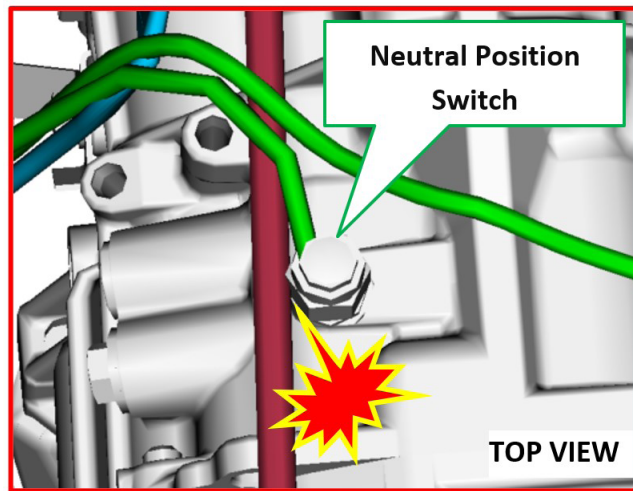

STEP 29: Loosen the back-up switch from the transmission case. Rotate the switch harness while turning the socket to prevent any excessive tension. The switch and the special tool cannot be removed together due to interference with the transmission case. Remove the tool before removing the switch.

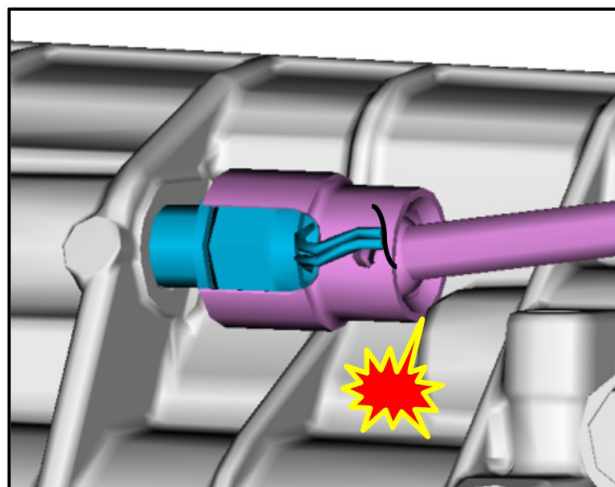

STEP 30: Install the new back-up switch with the new gasket. Rotate the switch by hand while turning its connector in order to avoid any twisting of the harness.

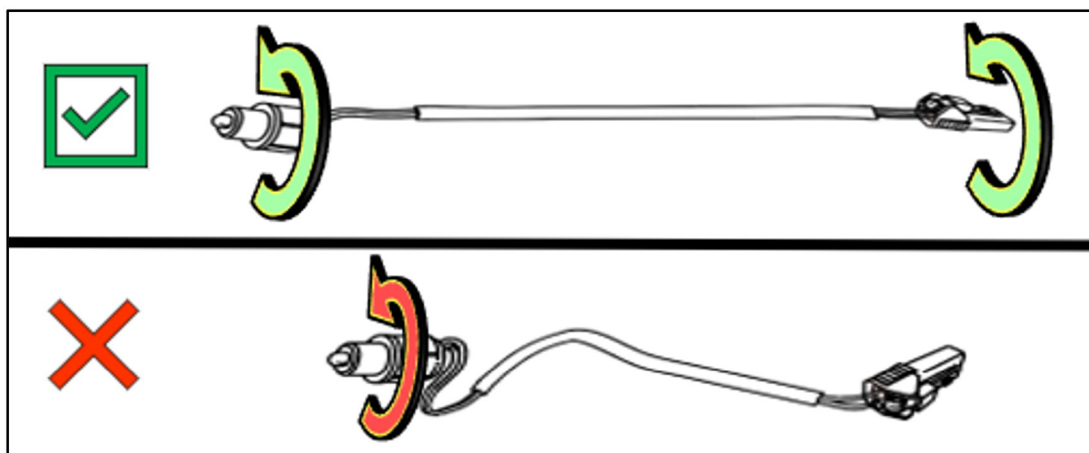

Continued...

STEP 31: Using the same precautions practiced in the switch removal, tighten the new switch and set the torque to **32Nm (23.6 ft-lb)**.

STEP 32: Connect the new back-up switch connector. Secure the wiring harness to the associated retaining bands.

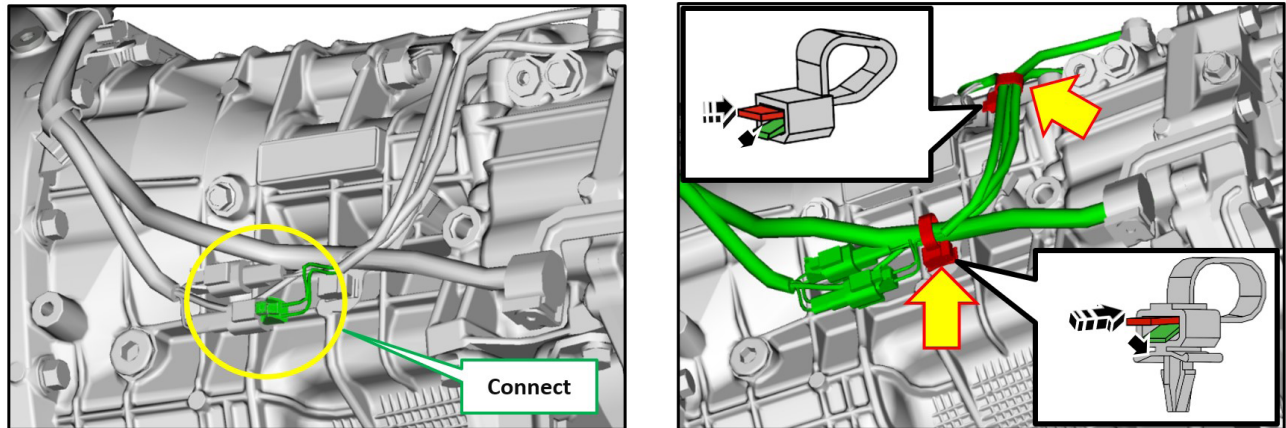

STEP 33: Lift the transmission with the jack and set gap between the upper edge of the dust cover and the floor pan to approximately 3 inches (70mm).

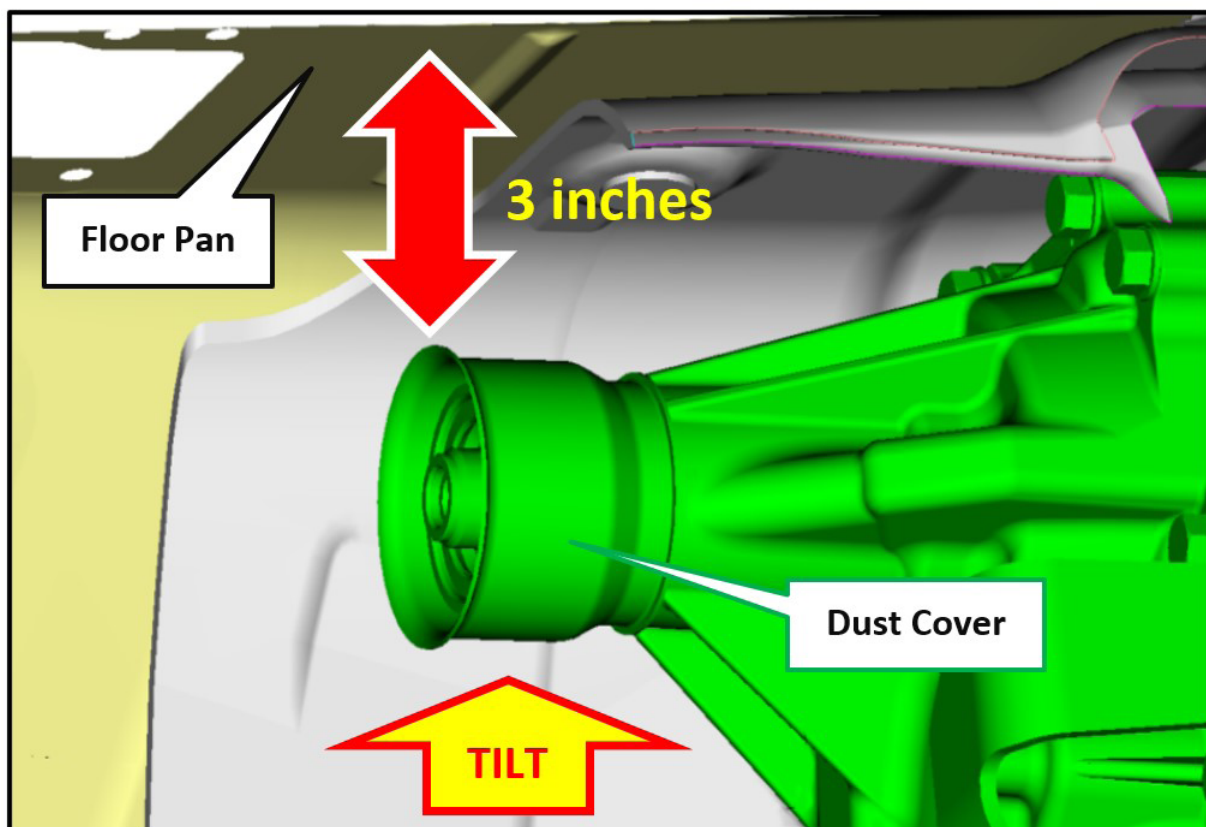

Continued...

STEP 34: Install the shift rod onto the shifter arm. Confirm that the holes are aligned.

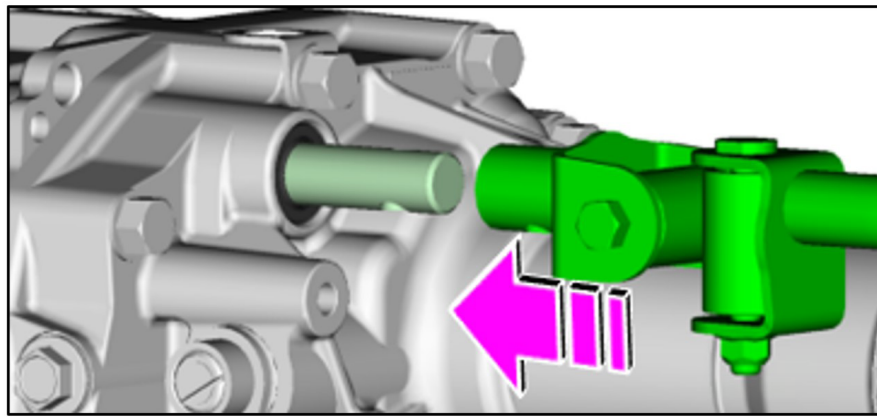

Tip: To prevent losing the positioning clip, attach a lead using string or wire.

Using Wire:

(1) Pre-cut an 18-19 gauge wire to 16 inches in length.

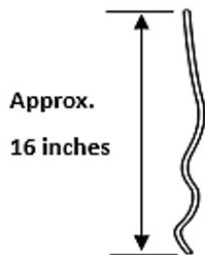

(2) Tie the wire to the clip.



(3) Insert the clip and hang the wire.

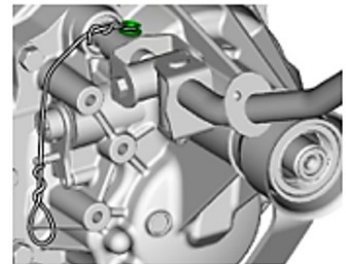

Using String:

(1) Pre-cut a string approx. 24 inches in length.

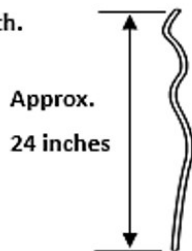

(2) Tie the string to the clip.



(3) Insert the clip and tie the string to the muffler bracket.

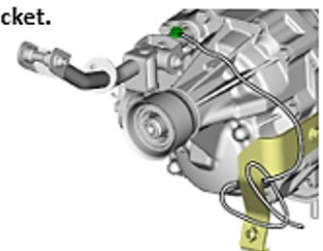

STEP 35: From the top side, insert the supplied positioning clip (p.n. 909130096) in the hole until the clip flange is fully seated.

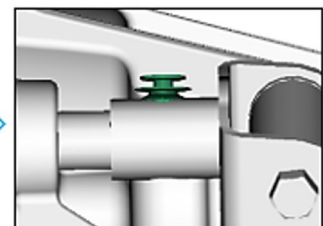
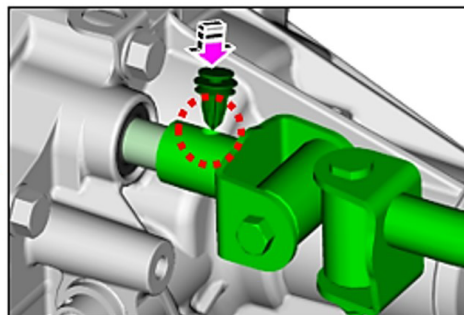
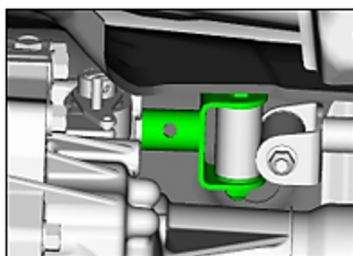

Continued...

STEP 36: With the clip installed, Position the shift rod in fourth gear (towards the rear of the vehicle). This will be the optimum position for installation of the spring pin.

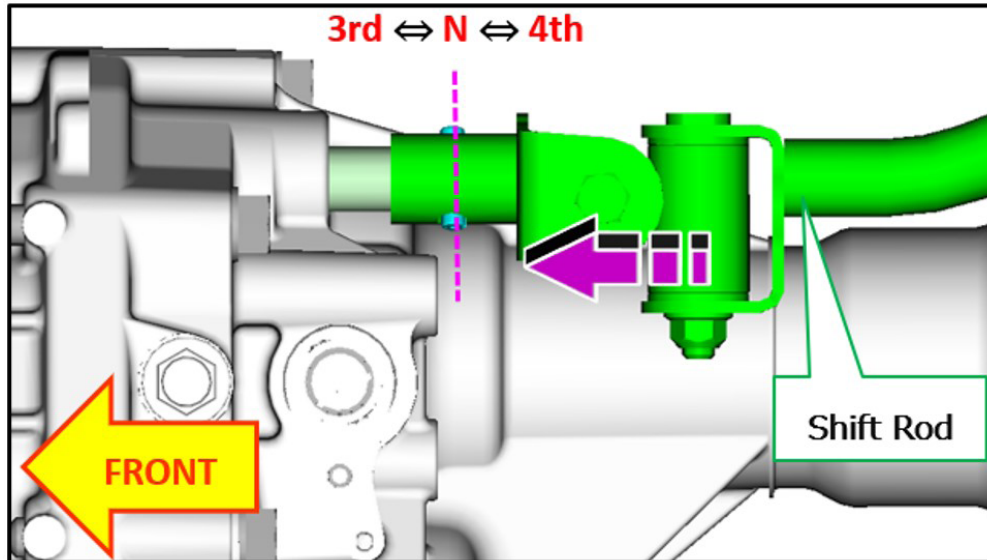

STEP 37: Attach the new spring pin to the tip of the 8mm punch with tape or rubber tubing. This will provide a more stable installation and help prevent any loss of the spring pin.

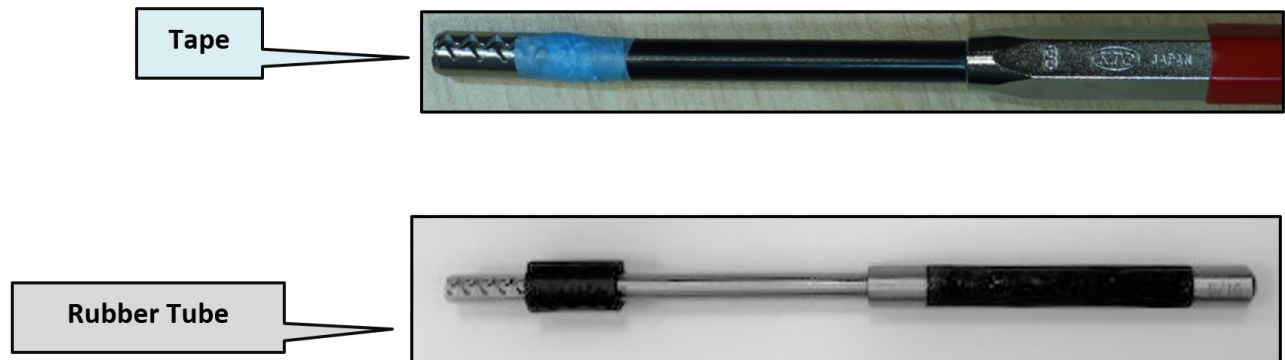

STEP 38: Install the new spring pin until the protruding portion of the spring pin is the same on both sides (approximately 1/8 inch (3mm)).

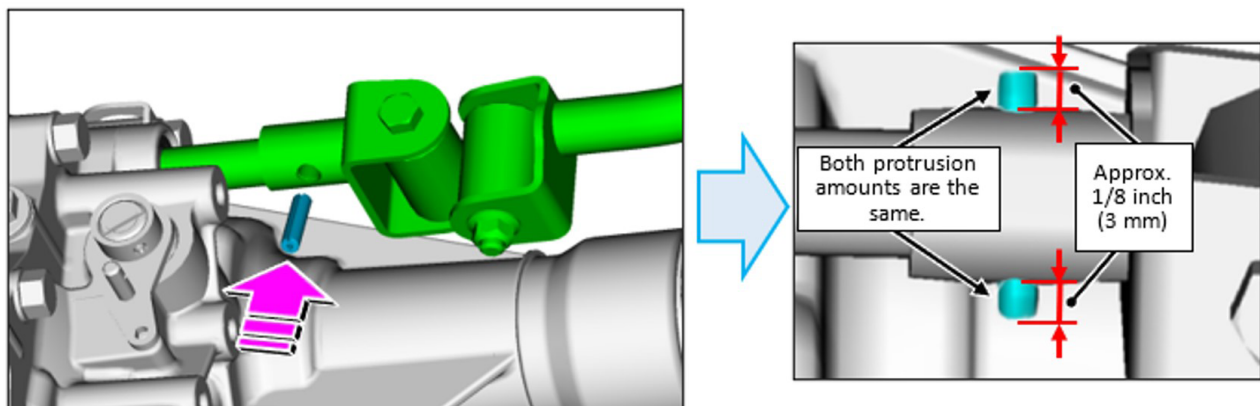

Continued...

CAUTION: The positioning clip will be driven out while installing the spring pin. Take particular care to not lose the positioning clip.

STEP 39: Position the shift rod into the neutral position (toward the front of the vehicle).

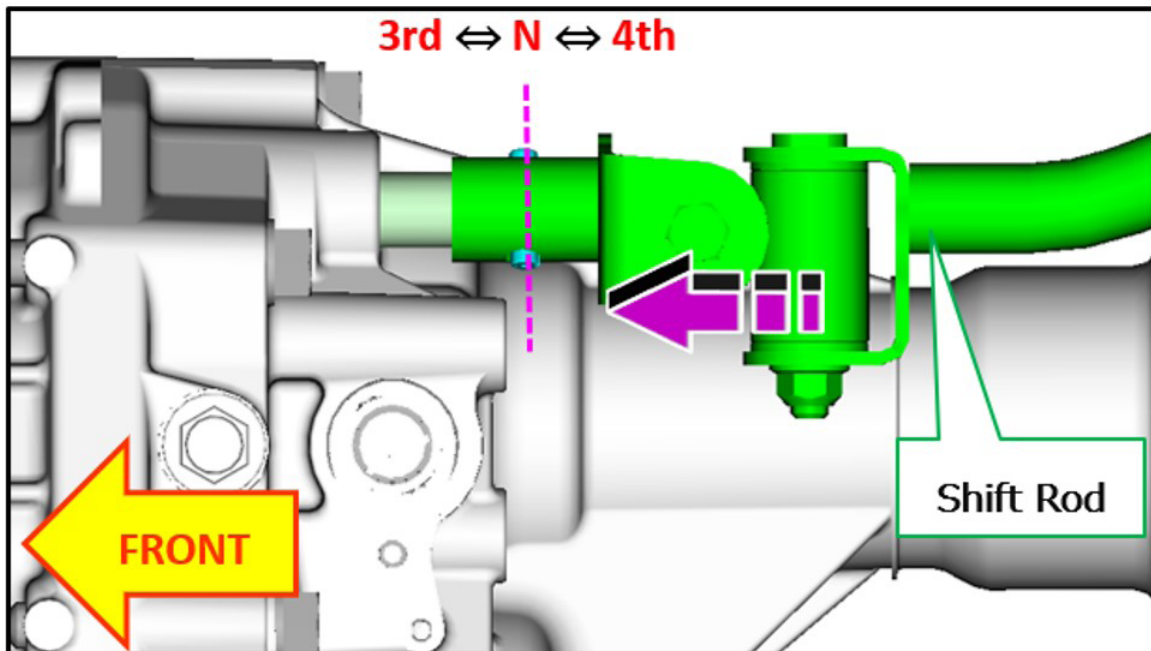

STEP 40: Install the shift bracket with the three mounting bolts torqued to **25Nm (18.4ft-lb)**.

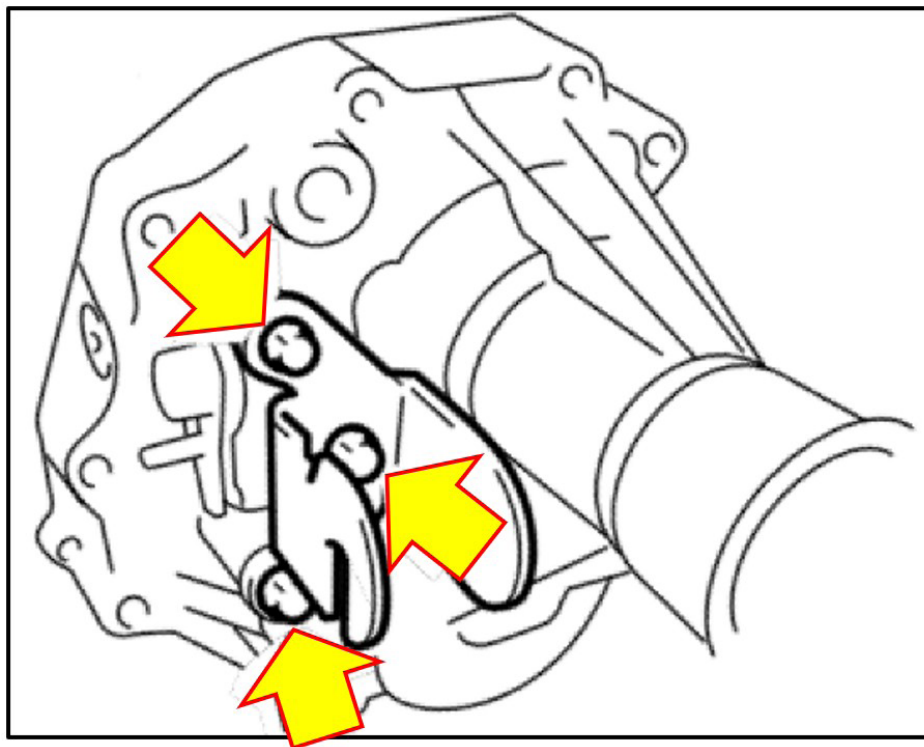

Continued...

STEP 41: Apply a thin layer of Conoco Philips Multiplex Red #2 (p.n. 000041000) to the contact portions between the shift bracket and stay bushing. This will help assist the installation.

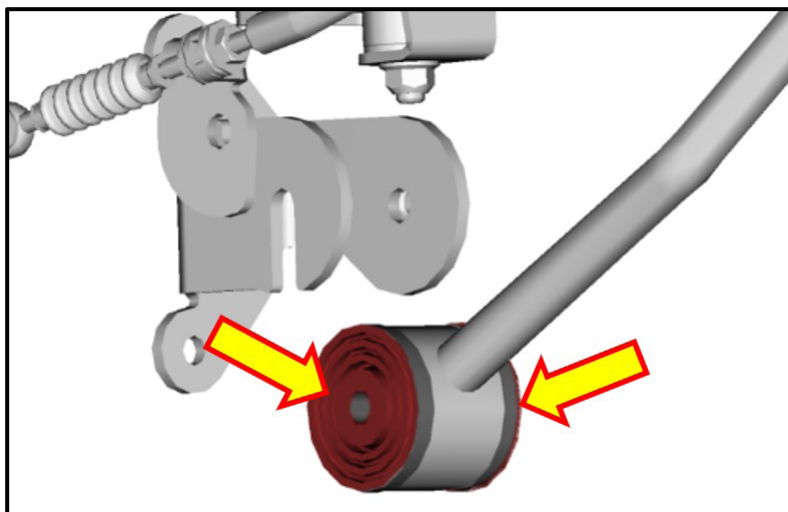

STEP 42: Apply a thin layer of Conoco Philips Multiplex Red #2 (p.n. 000041000) to the bushing of the reverse check cable its associated contact point.

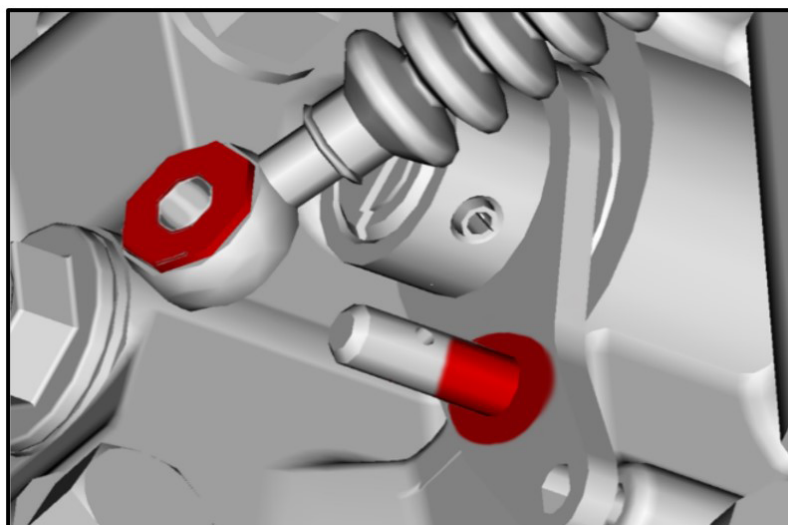

STEP 43: Install the stay, stay bolt, and cable plate into the shift bracket and tighten the bolt to 32Nm (23.6ft-lb).

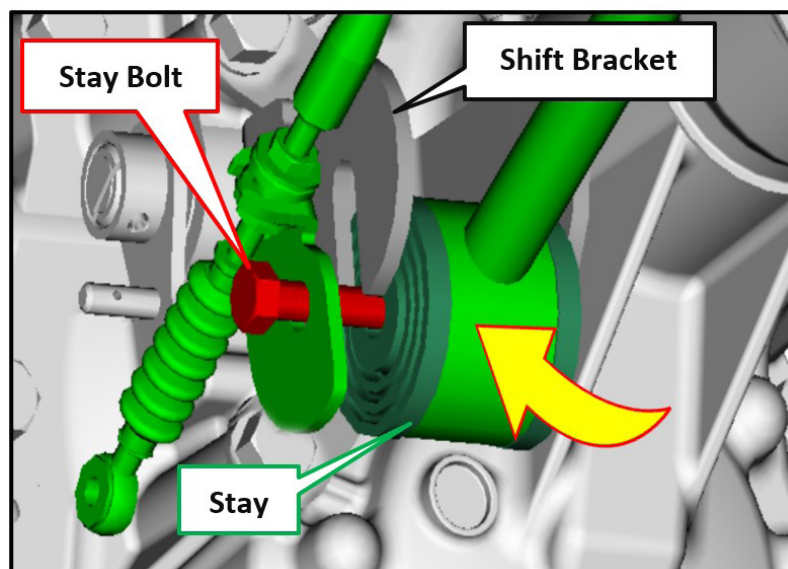

Continued...

CAUTION: Carefully align the claw for the cable plate with the groove of the shift bracket before tightening the stay bolt. If the bolt is tightened without this alignment, the plate can be damaged.

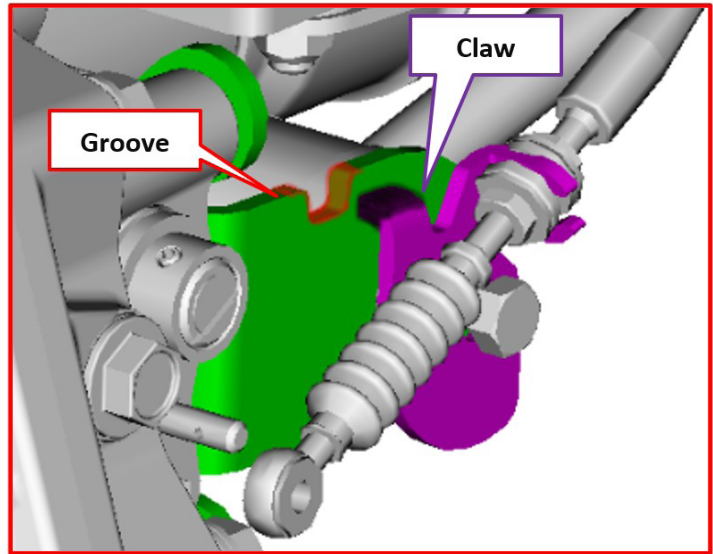

STEP 44: Install the reverse check cable to the reverse check lever. Secure the connection with the washer and locking snap pin.

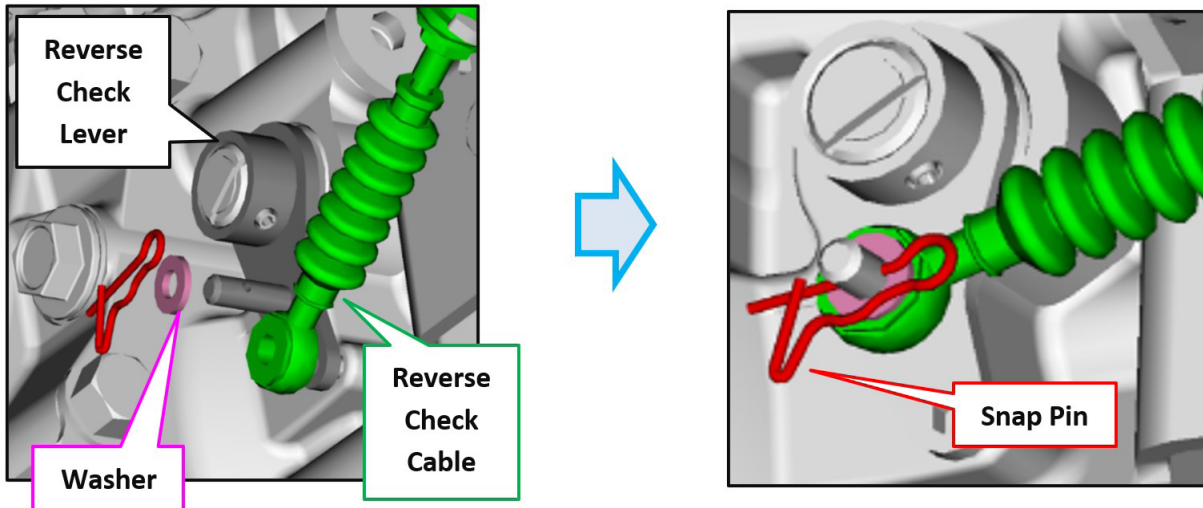

STEP 45: Install the cross member to the transmission with the two mounting nuts. Confirm the alignment is sufficient by adjusting the transmission jack if needed. Install the cross member to the vehicle body with the six mounting bolts. Torque all the mounting bolts. Once the torque procedure is complete, the transmission jack can be removed.

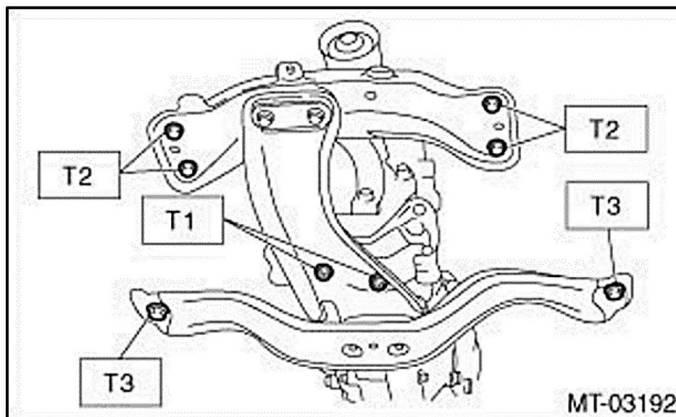

Torque Specification
T1: 35Nm (25.8ft-lb)
T2: 70Nm (51.6ft-lb)
T3: 140Nm (103ft-lb)

Continued...

STEP 46: Install the propeller shaft. Refer to the applicable Service Manual: [Driveline/Axle > DRIVE SHAFT SYSTEM > Propeller Shaft](#)

STEP 47: Install the center exhaust pipe and the rear exhaust pipe. Refer to the applicable Service Manual: [Engine > EXHAUST > Center Exhaust Pipe & Rear Exhaust Pipe](#)

NOTE: The Service Manual uses a **black star (★)** in the component breakdown illustrations to indicate one-time use parts. These parts have been supplied in the WRE-22 parts kit.

STEP 48: Install the lower transmission cover using clip (A), the two clips (C) and clip (D). Torque the two bolts (B) to **18Nm (13.3ft-lb)**.

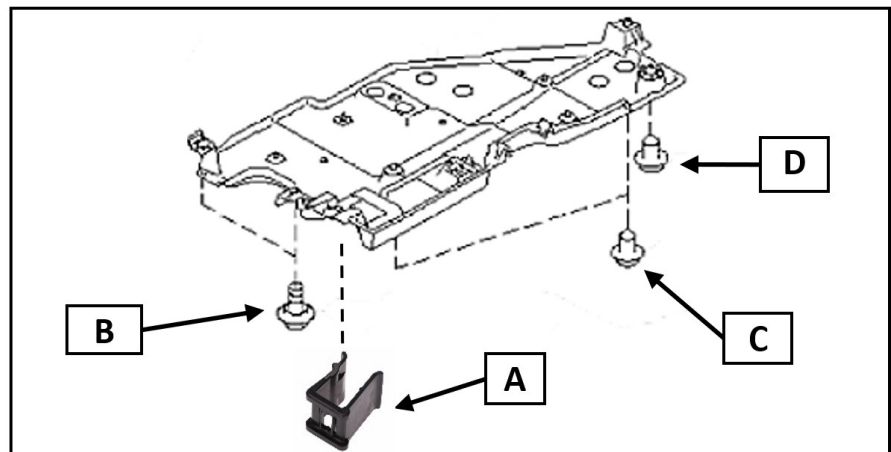

STEP 49: Lower the vehicle and confirm the parking brake is applied. 2019MY S209 models, install the STI flexible draw stiffener. Refer to the [S209 Service Manual](#).

Service Manual.

STEP 50: Install the pitching stopper with the two mounting bolts. Torque the vehicle body side bolt to **58Nm (42.8ft-lb)**. Torque the engine side mounting bolt to **50Nm (36.9ft-lb)**.

Continued...

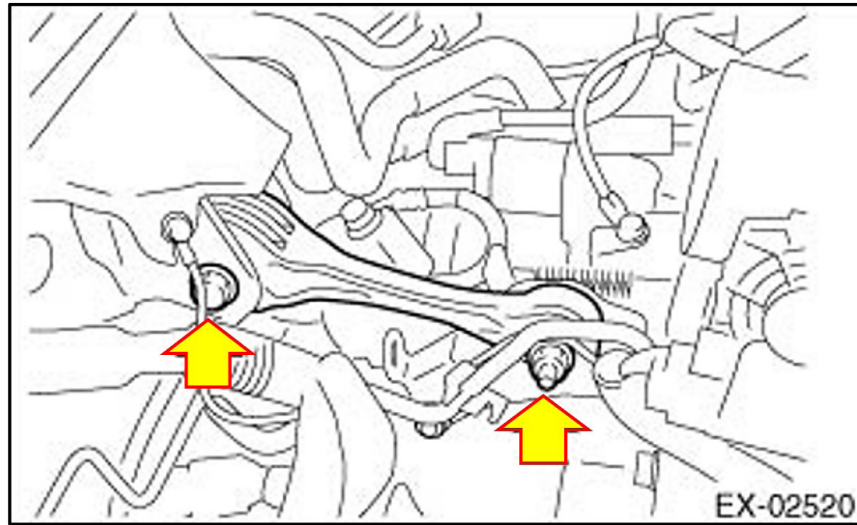

STEP 51: Install the nut and lock washer at the starter B connection to the starter motor and torque to **11Nm (8.1ft-lb)**.

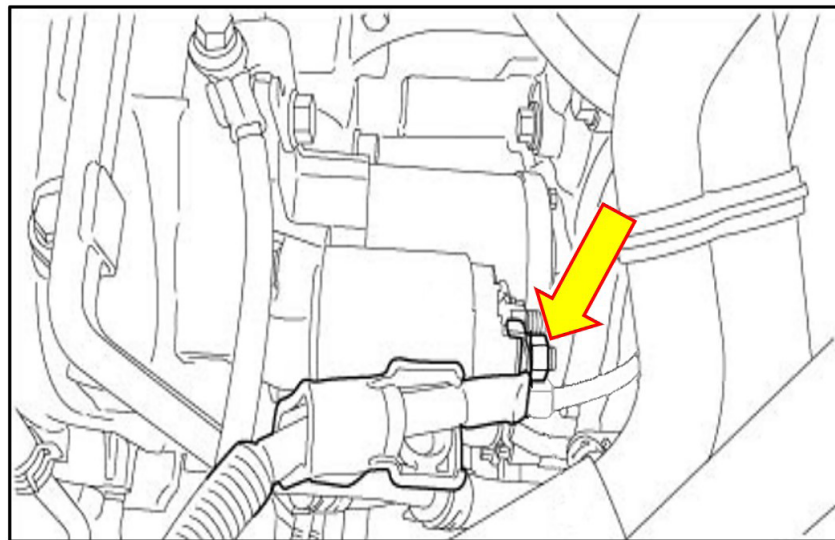

STEP 52: Reinstall the intercooler in accordance with the applicable Service Manual. Be mindful not to deform or damage the intercooler fins. For 2019MY S209 models, install the STI flexible Tower Bar. Refer to the [S209 Service Manual](#).

STEP 53: Install the secondary air pump as per the applicable Subaru Service Manual: [Engine > EMISSION CONTROL \(AUX. EMISSION CONTROL DEVICES\) \(STI\)](#)

STEP 54: Reconnect the engine coolant hoses to their associated holding clamps.

Continued...

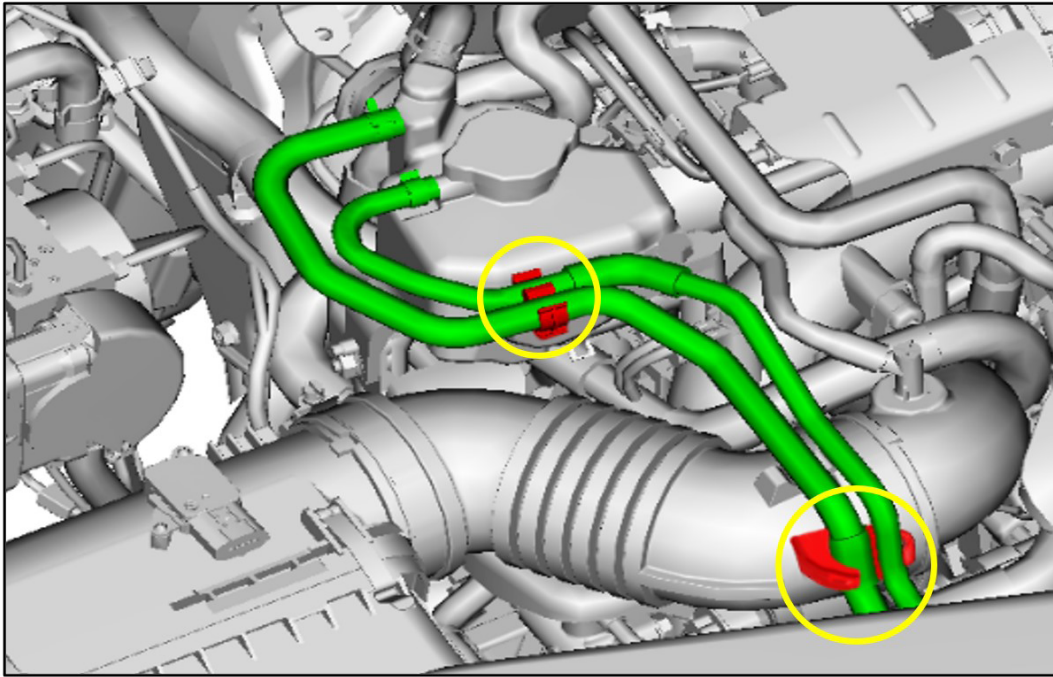

STEP 55: Install the air cleaner case. Tighten mounting nut A to **7.5Nm (5.5ft-lb)** and tighten mounting bolt B to **6Nm (4.4ft-lb)**.

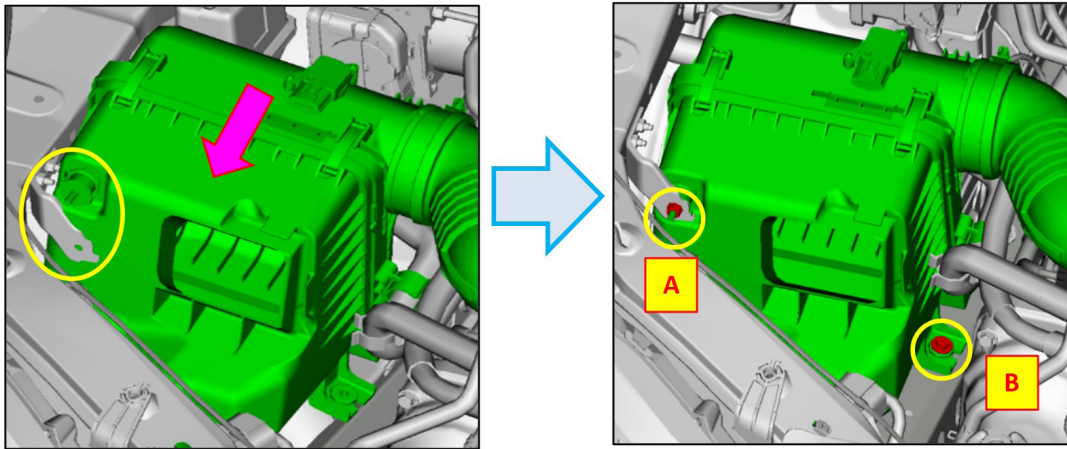

STEP 56: Install the air intake duct with the two mounting clips.

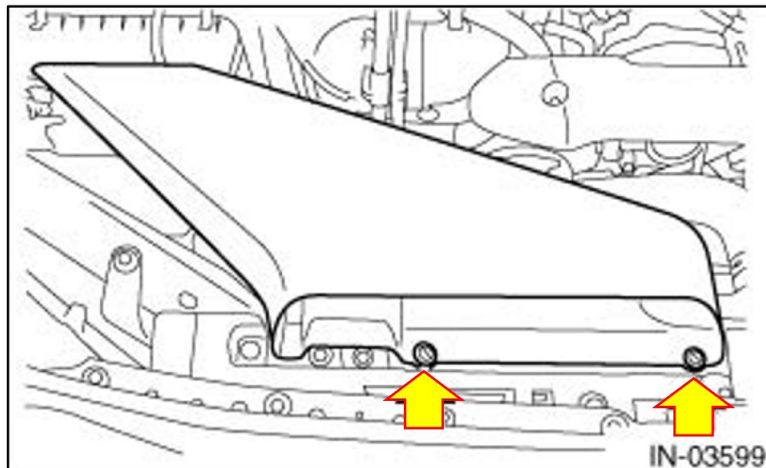

Continued...

STEP 57: Reconnect the ground cable terminal to the battery sensor, torque to 7.5Nm (5.5ft.-lbs. or 66inch-lbs.) while supporting the sensor with the other hand.

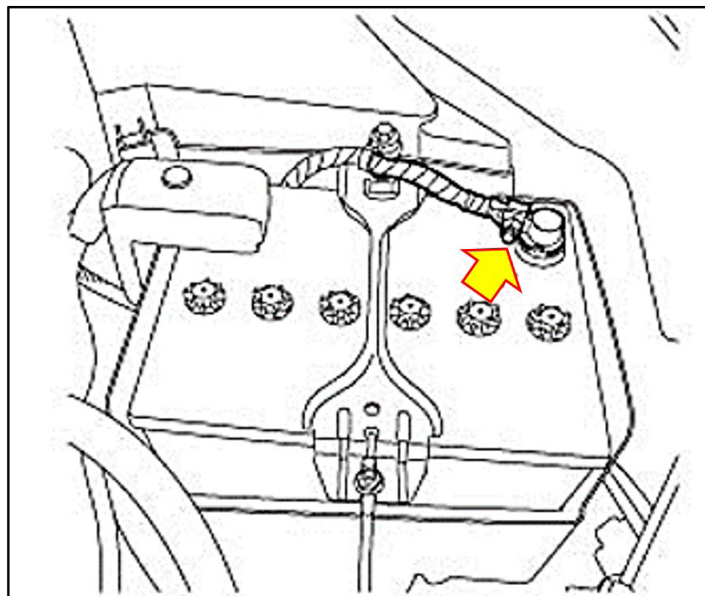

NOTE: If needed, clean the battery cable terminals and apply the approved protectant.

STEP 58: Perform and function test of the back-up switch by moving the shift lever into the reverse position and confirm the lamp illuminates when required.

CLAIM REIMBURSEMENT AND ENTRY PROCEDURES:

Credit to perform this recall will be based on properly completed repair order information. Retailers may submit claims through Subarunet.com.

Labor Description	Labor Operation #	Labor Time	Fail Code
WIRE HARNESS INSPECTION ONLY	A168-428	0.2	WRE-22
NON-S209 ISNECTION & BACKUP LAMP SWITCH REPLACEMENT	A168-421	1.7	
S209 INSPECTION & BACKUP LAMP SWITCH REPLACEMENT	A168-422	2.0	

Up to 10 cents can be claimed in sublet for Conoco Philips Multiplex Red #2 (p.n. 000041000).

IMPORTANT REMINDERS:

- SOA strongly discourages the printing and/or local storage of service information as previously released information and electronic publications may be updated at any time.
- Always check for any open recalls or campaigns anytime a vehicle is in for servicing.
- Always refer to STIS for the latest service information before performing any repairs.

Continued...

**URGENT
IMPORTANT SAFETY RECALL**



PO Box 9103
Camden, NJ 08101-9877
844-373-6614
www.subaru.com

**Subaru Safety Recall WRE-22
NHTSA ID 22V-522
September 2022**

SERVICE PROGRAM IDENTIFICATION LABEL:

Type or print the necessary information on a Campaign Identification Label. The completed label should be attached to the vehicle's upper radiator support. Additional labels are available through normal parts ordering channels. The part number is MSA6P1302, which comes as one sheet of 20 labels.

Part Number	Applicability	Description	Order Quantity
MSA6P1302	All Models	Campaign Completion Labels (contains one sheet of 20 labels)	1

SUBARU
Campaign Code
WRE-22
COMPLETED
DIST./DEALER NO.
SERIAL NO.
DO NOT REMOVE

Dear Subaru Owner:

This notice is sent to you in accordance with the National Traffic and Motor Vehicle Safety Act.

SUBARU OF AMERICA, INC. has decided that a defect, which relates to motor vehicle safety, exists in certain 2015-2021 model year WRX STI vehicles.

You received this notice because our records indicate that you currently own one of these vehicles.

DESCRIPTION OF THE DEFECT

Your vehicle may contain a defective back-up lamp switch, which may cause the back-up lamps to not illuminate, the rear-view camera (if equipped) to not display an image, and the select lever/gear position indicator in the combination meter to not display 'R' when driving in reverse.

SAFETY RISK

If the back-up lamps do not illuminate when the vehicle is in reverse gear, this may reduce

the awareness of other motorists or road users of the driver's intention to operate the vehicle in reverse, increasing the risk of a crash. Additionally, a rear-view camera that does not display an image can reduce the driver's view of what is behind the vehicle, increasing the risk of a crash.

WHAT SUBARU WILL DO

Subaru will conduct an inspection and replace the back-up lamp switch with improved one, if necessary, at no cost to you.

WHAT YOU SHOULD DO

Please contact your Subaru retailer (dealer) immediately for an appointment to have this repair performed, at no cost to you.

Until this repair is performed, please use caution when driving in reverse. You should always check the rear view and the surrounding area by turning your head rearward and/or using the mirrors and move backward at a slow speed.

HOW LONG WILL THE REPAIR TAKE?

The time it will take to inspect your vehicle is less than fifteen minutes. If it is found that the switch needs to be replaced, the time for this repair is approximately two hours. However, it may be necessary to leave your vehicle for a longer period of time on the day of your scheduled appointment to allow your Subaru retailer flexibility in scheduling.

OWNER INFORMATION

Government regulations require that recall notifications be sent to the last known owner of record. That information is based primarily on state registration and title data. If you are a lessor of this vehicle, federal regulations require you to forward this notice to your lessee within ten days.

If you have moved or sold your vehicle, please go to <https://www.subaru.com/support/customer-support.html> to send us your information.

IF YOU HAVE PREVIOUSLY PAID FOR A REPAIR

If you have already paid for repairs associated with this condition, you may be eligible for reimbursement. Reimbursement consideration will be based on the amount an authorized Subaru retailer in your area would charge for the same repair.

Please send the original service repair order, which has the name of the repair facility, date of repair, mileage at the time of repair, complete 17-digit vehicle identification number (VIN), and your name, with correct mailing address and telephone number to the address listed below.

Subaru of America, Inc.
Customer Advocacy Department, Attention: WRE-22 Recall
P.O. Box 9103, Camden, NJ 08101-9877

Continued...

Please send original receipts only and retain a photocopy for your records. Please be assured that we will attempt to process your reimbursement request as quickly as possible, but it may take up to 60 days for this process to be completed.

IF YOU NEED FURTHER ASSISTANCE:

To locate the nearest Subaru retailer, you can access our website at www.subaru.com and select 'Find a Retailer.'

For additional information, please go to: <http://www.wre22.service-campaign.com>.

If you need additional assistance, please contact us directly:

- By e-mail: Go to www.subaru.com and select "Customer Support"
- By telephone: 1-844-373-6614
Monday through Friday between 8:00 a.m. and 7:00 p.m. ET
- By U.S. Postal mail: Write us at Subaru of America, Inc.
Attn: Customer Advocacy Department
P.O. Box 9103, Camden, NJ 08101-9877

To subscribe to the NHTSA Recall Notification email System, please go to: <https://www-odi.nhtsa.dot.gov/nhtsa/subscriptions>.

Please contact us immediately if the Subaru retailer fails or is unable to make the necessary repairs free of charge.

You may also contact the Administrator, National Highway Traffic Safety Administration (NHTSA), 1200 New Jersey Ave., SE, Washington, DC 20590 or call the toll-free Vehicle Safety Hotline at 1-888-327-4236 (TTY: 1-800-424-9153) or go to <http://www.NHTSA.gov> if you believe the Subaru retailer has failed or is unable to remedy your vehicle without charge within a reasonable amount of time.

Your continued satisfaction with your Subaru is important to us. Please understand that we have taken this action in the interest of your safety and your vehicle's proper operation. We sincerely apologize for any inconvenience this matter may cause and urge you to schedule an appointment as soon as possible.

Sincerely,

Subaru of America, Inc.

A subsidiary of SUBARU CORPORATION