

Technical Service Bulletin

Topic	Seat Belt Presenter - Intermittent Operation
Market area	Bentley: worldwide (2WBE)
Brand	Bentley
Transaction No.	2034323/7
Level	EH
Status	Released for publishing
Release date	Sep 19, 2022

New customer code

Object of complaint	Complaint type	Position
occupant protection, passenger protection -> seat belts	functionality	

Vehicle data

Continental GT and GTC

Sales types

Type	MY	Brand	Designation	Engine code	Gearbox code	Final drive code
393*	2012	E		*	*	*
393*	2013	E		*	*	*
394*	2012	E		*	*	*
394*	2013	E		*	*	*

Chassis numbers

Manufacturer	Filler	Type	Filler	MY	Factory	From	To	Prod from	Prod to
SCB	**	*	*	*	C	069713	086182		

Documents

Document name
master.xml

Condition

Front seat belt system presenter intermittent in operation

Technical Background

The front seat cushions occupancy sensor may intermittently, dependant on occupant size and posture, fail to deploy the seat belt presenter. This can be attributed to changes in the sensor status from occupant present to occupant not present during the process of entering the car, closing the door and shifting load applied onto the seat

Production Solution

A new control module fitted from VIN SCBFK63W0DC086182 has increased hysteresis in respect to its response to the occupancy status input. In effect the control module will maintain an occupied status for a maximum of 3 seconds, after the sensor changes to an unoccupied state

Service

In the event of a customer reporting front seat belt presenter intermittent operation then the following procedure should be considered as part of your diagnosis

1. If the fault occurs with a petite, low percentile person (approximately 5th percentile) then only Operation 2 is valid for a system improvement
Note: The following details the process for the right hand front seat the same procedure should be performed on the left hand front seat at the same time even if the presenter function is not suspect on the adjacent seat
2. Endeavour to qualify the customer concern ensure that the concern fits the criteria for this TPI

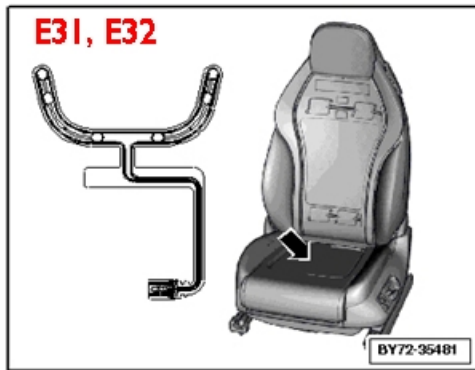

Figure 1

3. First check the occupancy sensor, E31, is function correctly (see Figure 1)



Figure 2

- Disconnect connector T2ge at the occupancy sensor (E31 Drivers, E32 Passengers). The 2 way connection can be identified by its blue connector housing located under the seat frame adjacent to the inboard seat runner (see Figure 2)

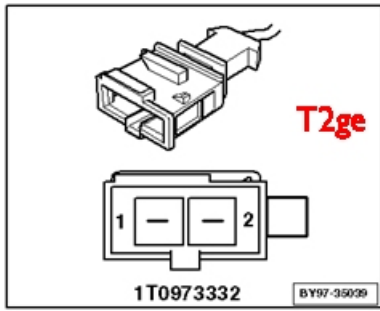

Figure 3

- With T2ge connector disconnected and an occupant sat in a natural position on the seat, with their back against the backrest, measure the resistance through the occupancy sensor (see Figure 3)

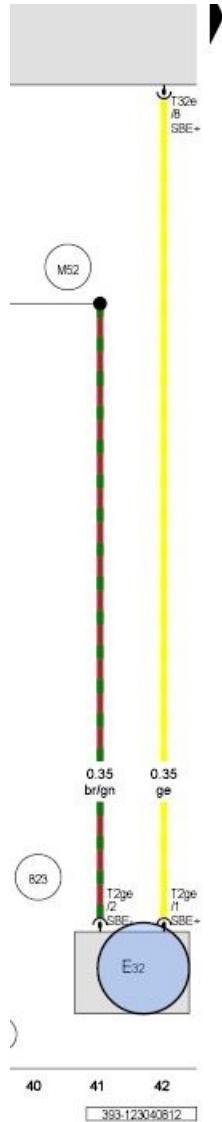

Figure 4

- If the resistance of the sensor with the seat occupied is greater than 90 Ohms then the sensor is faulty and should be replaced
- Once the occupancy sensor is known to function to specification (operation 2) then remove and discard the original seat adjustment control unit with memory (J136 Drivers, J521 passengers) and replace with the latest level part (part number 4W0.959.760)
 - The J136, J521 seat control unit is located under the seat frame reference workshop manual Rep. Gr.72 Front seat control unit (J136,J521) – To remove and fit

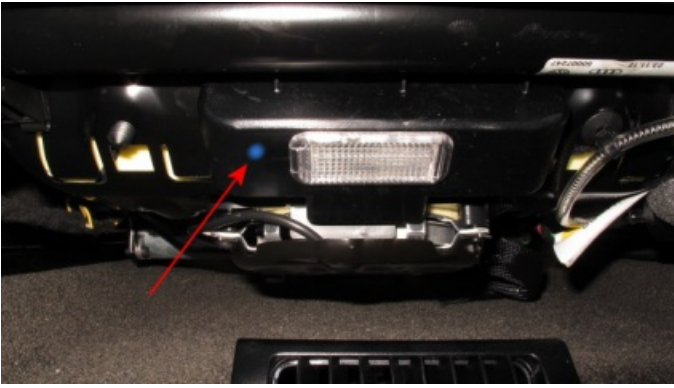

Figure 5

6. Once both seat control modules have been change to part number 4W0.959.760 then apply a blue paint spot to each seat base adjacent to the rear footwell lamp (see Figure 5)

Warranty

To replace the seat occupancy sensor

Warranty Type	110 or 910
Labour Operation Code	69 56 49 00
Damage Service Number	69 56
Damage Code	00 40
Time	140 TU

To replace the seat control module

Warranty Type	110 or 910
Labour Operation Code	72 93 49 00
Damage Service Number	72 93
Damage Code	00 40
Time	50 TU

Required Parts and Tools

Original part number	Replacement part number
3W3.959.760	4W0.959.760