

Technical product information

Topic	Fitment of rear brake caliper carriers for complaints relating to 3.4 KHz rear brake squeal
Market area	Bentley; worldwide (2WBE)
Brand	Bentley
Transaction No.	2066143/4
Level	EH
Status	Approval
Release date	

New customer code

Object of complaint	Complaint type	Position
running gear -> brakes, brake control	noise, vibration	
running gear -> brakes, brake control -> service brake	noise, vibration -> noise	
running gear -> brakes, brake control	component / consumables	

Vehicle data

Bentayga series

Sales types

Type	MY	Brand	Designation	Engine code	Gearbox code	Final drive code
4V1*	2017	E		*	*	*
4V1*	2018	E		*	*	*
4V1*	2019	E		*	*	*
4V1*	2020	E		*	*	*
4V1*	2021	E		*	*	*
4V1*	2022	E		*	*	*

Documents

Document name
master.xml

Customer statement / workshop findings

Rear brake squeal (3.4 KHz) during brake application at low speed

Refer to the Brake Noise Identification TPI 2052785/- to confirm the frequency, ensure the operative attaches all applicable information including sound files/photos and videos to the DISS query

Technical background

Revision History 2066143/2

- Header data revised
- Steps 9 and 11 added

2066143/3

- Addition of Figures 1,2,3,4 and 6
- Note added after Figure 6 requesting the operative to check to confirm the brake calliper carriers have been fitted to specification

Production change

-

Measure

-

Left and right hand side orientation is referred to within this document

The left and right hand should be determined as viewed by the operative when standing on the underside of the vehicle and looking/facing towards the front

NOTE: Within the Rep.Gr procedures quoted within this document there are single use items which must be replaced and not reused. Ensure that new replacements are available prior to starting this procedure

1) Remove the left and right hand rear brake discs including the rear carriers as per Rep.Gr 46

-

The rear brake discs should be replaced in the event that the discs are not to specification as per Rep.Gr 46 - Brake discs - Checking condition and run-out

- Discard all previously removed parts as per all local environmental guidelines

-

Ensure all mating surfaces and brake components which are to be refitted (including rear brake callipers and the piston faces) are clean before reassembly

2) Referring to Rep.Gr 46 - Fit the left and right hand rear brake discs

3) Referring to Rep.Gr 46 - Fit the left and right hand rear carriers as follows:

Black

- 36A698425 - Left hand side (Figures 1 and 2)
- 36A698426 - Right hand side (Figures 3 and 4)

Red

- 36A698425A - Left hand side (Figures 1 and 2)
- 36A698426A - Right hand side (Figures 3 and 4)



Figure 1

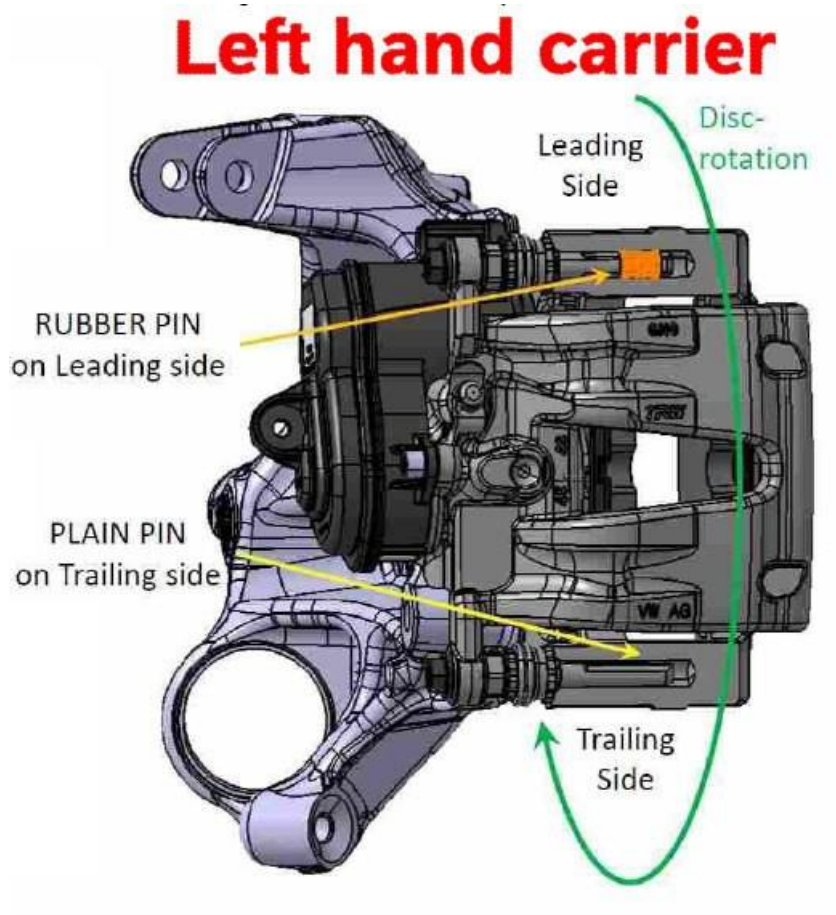

Figure 2



Figure 3

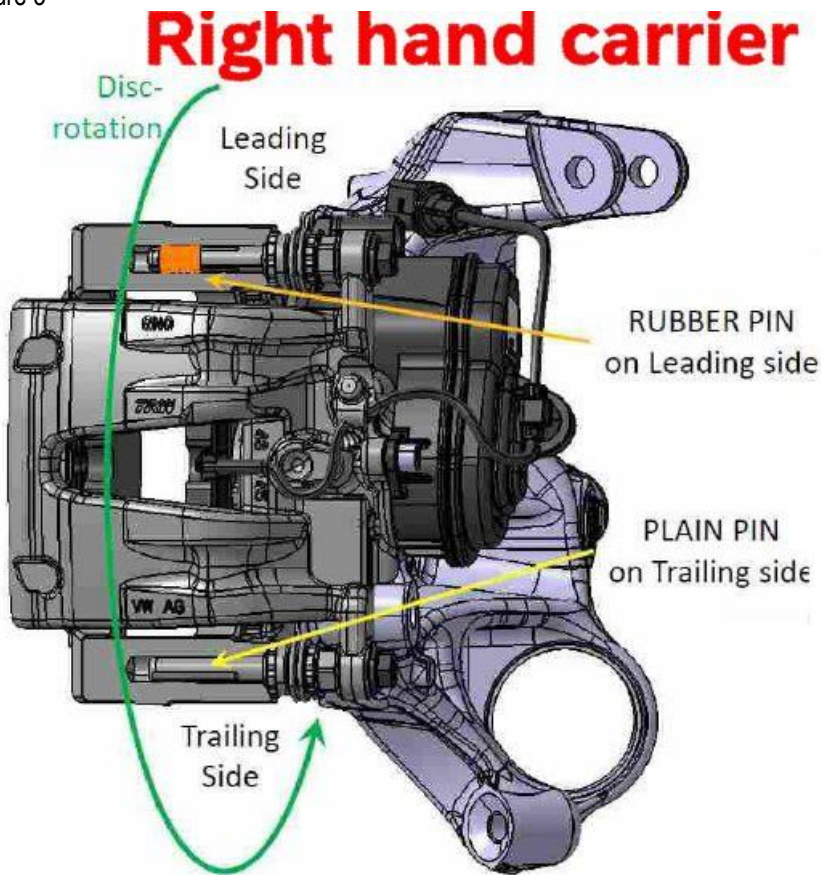

Figure 4

VERY IMPORTANT: Do not under any circumstances remove the rubber guide pins (Figure 5) from the new carriers as they have a predetermined level of grease applied that MUST not be disturbed

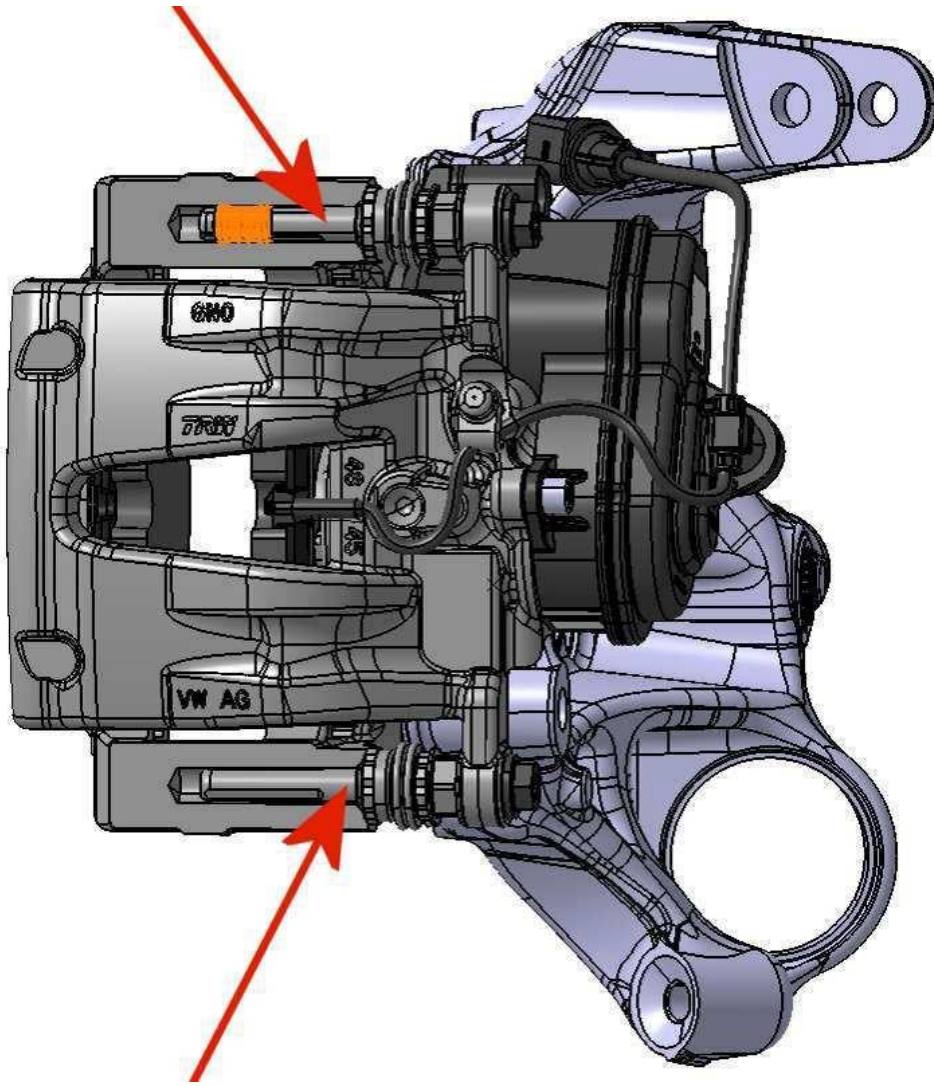

Figure 5

VERY IMPORTANT: Figure 6 shows the location in which the rubber pins should be positioned once the callipers have been fitted to specification

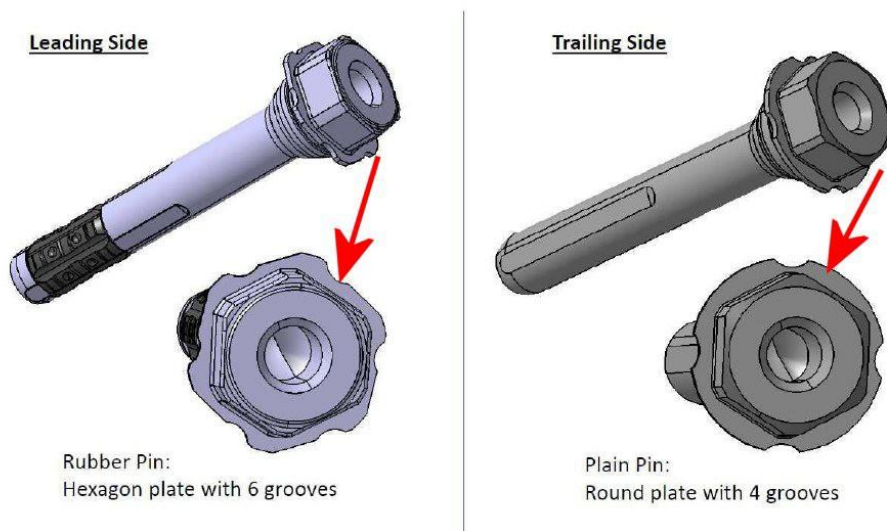

Figure 6

NOTE: The next part of the process details brake pad shim fitment - Follow the remaining steps until completion

4) Install one shim to each rear brake pad as detailed below

▪

VERY IMPORTANT: Referring to Figure 7, the design of the shims (A and B) are different in appearance from the shims (C and D)

A - 36A 698 219 B

B - 36A 698 219 A

C and D - 36A 698 219

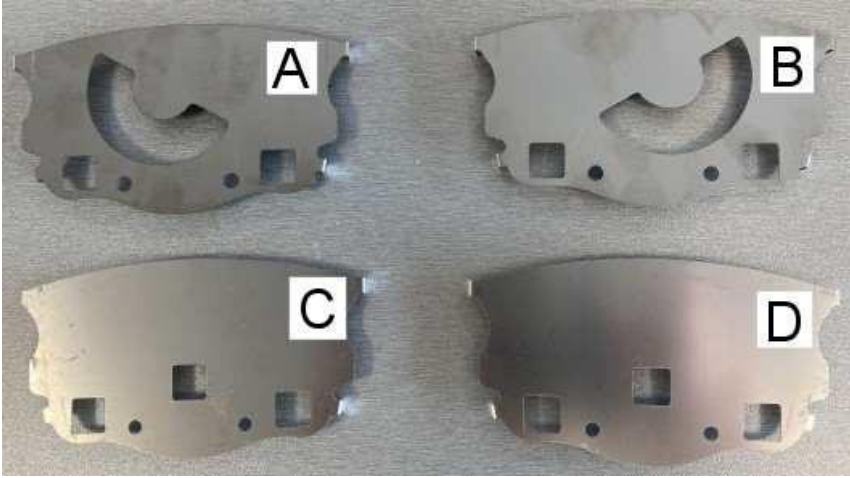

Figure 7

5) Referring to Figure 8 - Apply 6 dots of grease (<1.0g in total) to the inside face of the clip on each shim (x4 in total)

TIP: Grease application is the same process regardless of shim design



Figure 8

- Referring to Figure 9 - Using a suitable spatula spread the grease to an even layer condition (x4 shims in total)



Figure 9

6) Referring to Figure 10 - Assemble the clip-on shim onto each pad, the pads **MUST** be fitted in the positions as detailed:

- 1 - Lefthand outer pad
- 2 - Left hand inner pad
- 3 - Righthand inner pad
- 4 - Righthand outer pad



Figure 10

7) Once each shim has been assembled to each pad - Squeeze together firmly to remove any excess grease which comes out from between the new shim and the brake pad bonded shim

IMPORTANT: Ensure ALL excess grease is removed prior to fitting the brake pads

NOTE: Ensure the new shim is seated flat against the brake pad bonded shim

8) Referring to Figures 11 and 12 - Apply a small dot of grease to the pad abutments and the springs of each pad



Figure 11



Figure 12

- Wipe the face of the piston to remove any brake dust or dirt
- Refit the rear brake pads as per Repair manual Rep.Gr 46 - Rear Brake Pads - To Remove and Fit, taking care not to dis-lodge the grease/shims before the pads are in position

For clarity once fitted the brake pads MUST be positioned as shown in Figure 13 (with reference to Figure 10)



Figure 13

9) Once the vehicle has been assembled check to confirm the shims have been fitted correctly (as per previous instructions)

CAUTION: if visibility of the shim from the exterior is as shown in Figure 12 the shims are NOT positioned correctly, in this scenario please refer back to the previous instructions to ensure the shims are fitted correctly

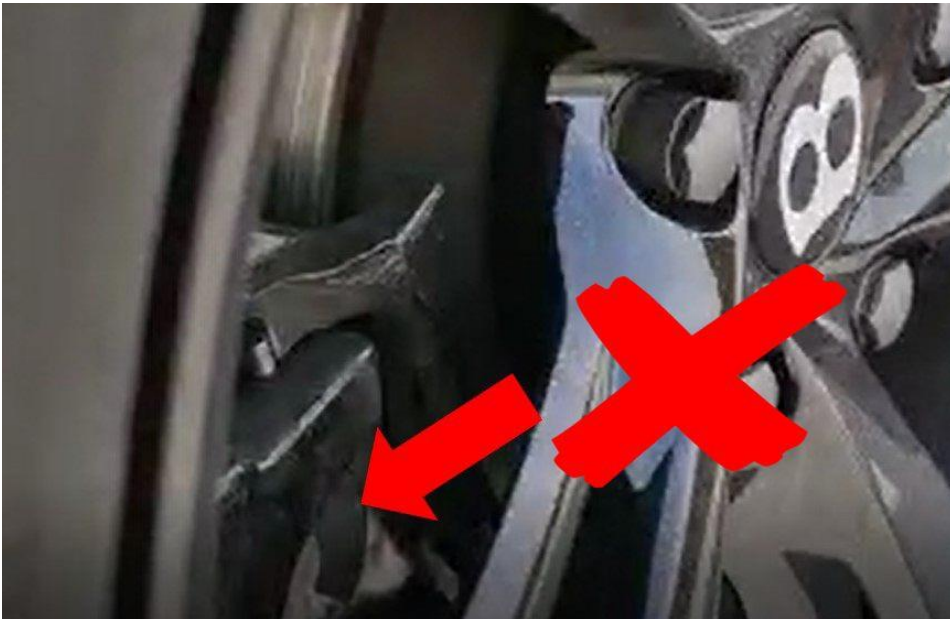

Figure 14

10) Carry out a Road test

VERY IMPORTANT: On return from road test, visually check for any excess grease which may have come out from between the shims/pads - Remove any excess grease immediately with a suitable cleaner/cloth

11) Raise a Non-technical DISSquery confirming the following:

- The issue is no longer evident
- The instructions were followed as detailed
- The shims were installed as per the instructions

Warranty accounting instructions

Time to install shim set

WarrantyType 110 or 910

Damage Service Number 46 38

Damage Code 00 20

Labour

Labouroperationcode 46384250

Time 20 TU

Time to replace the rear brake pads and discs (If discs are required)

Labouroperationcode 46382050

Time 50 TU

Time to remove and refit rear wheels

Labouroperationcode 44052000

Time 10 TU

Time to replace the rear carriers

Labouroperationcode 46151950

Time 10 TU

Road test

Labouroperationcode 01210000

Time 50 TU

Parts information

Part number	Description	Quantity
G 052 560 A2 (See note below)	Vary Bond grease	1 = 1 x 100 gram
36A 698 147	Service kit (Black)	1
36A 698 147A	Service kit (Red)	1
<i>Refer to ETKA (To be sourced by retailer if required)</i>	Rear brake discs (Left)	1 (As required)
<i>Refer to ETKA (To be sourced by retailer if required)</i>	Rear brake disc (Right)	1 (As required)
<i>Refer to ETKA (To be sourced by retailer)</i>	Carrier fixings	4
<i>Refer to ETKA (To be sourced by retailer)</i>	Carrier to Caliper fixings	4

IMPORTANT: 1 tube of vary bond grease can be used on multiple vehicles (approximately x1 tube can be used on up to a maximum of 20 vehicles)

Do Not order more grease in the event that you already have stock