



A/C ELECTRICAL CONNECTION INSTRUCTIONS

Bulletin Type:	TSB	Publication Date:	September 2022
Bulletin #(s):	22-075	Make(s):	Jayco & Entegra Coach
Job Code(s):	9803579	Model(s):	Launch (19Y, 19L) Terrain (19Y, 19L) Ethos LI (20AL, 20TL) Swift LI (20AL, 20TL)
Flat Rate(s):	9803579A - .20 Inspection 9803579B - .50 Inspection and Repair		Model Year(s):

Incident:	Wago connector installed instead of Blue wing-nut connector
Affected Units:	Certain 2021-2023 Jayco Terrain and Swift LI; Certain 2021-2023 Entegra Coach Launch and Ethos LI
Parts List:	2 - CONNECTOR,WIRE NUT W/WG BLU (Jayco Part #0011265) (Purchase Locally)
Misc. Tools & Supplies:	Screwgun with Square Bit Wire Strippers
Parts Return Information:	N/A

A/C BLUE WING-NUT CONNECTOR INSPECTION

1. Begin by lowering bed to access the rear A/C.
2. Remove the air conditioner plenum.
 - a. Remove both grills and filters, set aside for reinstall. (Figure 1)
 - b. Remove (4) fasteners and plenum, set aside for reinstall. (Figure 1)

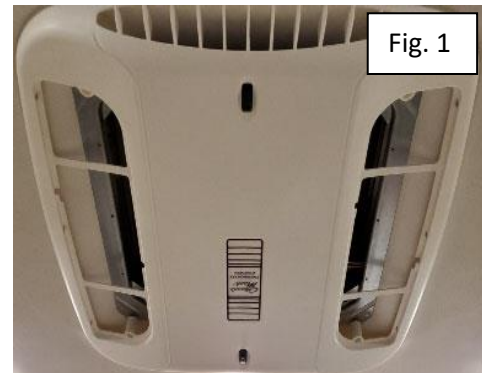

3. Remove (6) fasteners from internal blower cover and set aside for reinstall. (Figure 2)
4. Complete the repair instructions below to replace the wago connectors with blue wing nut connectors within the A/C electrical connections. (Figure 3) File claim for inspection only if the installation of blue wing nut connectors is completed.

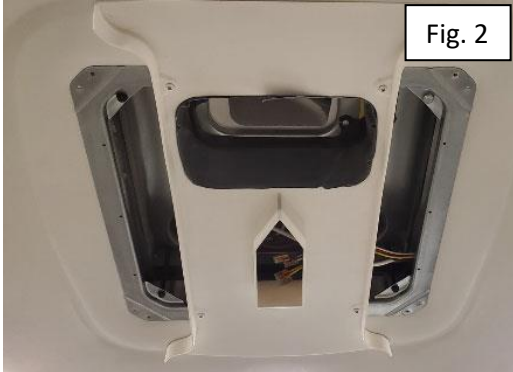

Fig. 2

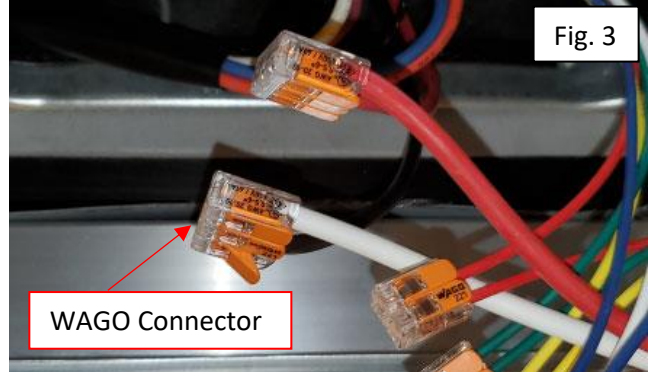

Fig. 3

WAGO Connector

A/C BLUE WING-NUT CONNECTOR REPAIR INSTRUCTIONS

1. Turn off all charging sources, including the engine, shore power, rooftop solar, and any external solar prior to using the self-locking button.
2. Turn off the lithium battery before making any electrical changes.
3. Begin by locating the Lithium Battery Self-Locking Button to turn off the battery.
 - a. Ethos Li and Swift Li – the Self-locking Button is located under the bed base access near the battery. (Figure 4)
 - b. Launch and Terrain – the Self-Locking Button is either located on the front wall (Figure 5) or in the rear lithium battery access (Figure 6).

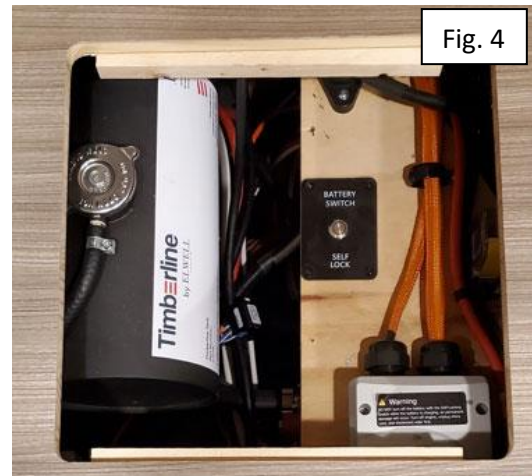

Fig. 4



Fig. 5

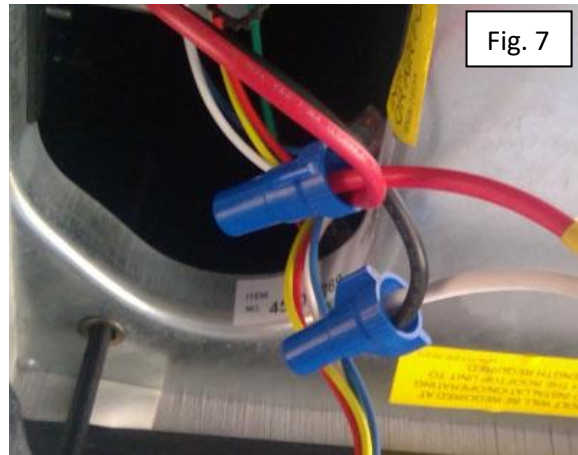

Fig. 6

4. Decompress the Self-Locking Button to turn off the lithium battery system.

5. Replace WAGO connector with Blue Wing-Nut Connector: Red to Red wiring (Fig. 7)

- a. Remove WAGO connector for the Red to Red wire connection
- b. Using wire cutters, cut ends of exposed wiring on both Red wires.
- c. Using wire strippers, strip wire 5/8" (15.9 mm).
- d. Pre-twisting wiring is unnecessary. Hold stripped wires together with ends even.
- e. Align any frayed strands or conductors.
- f. Push wires firmly into connector and screw on connector.



6. Replace WAGO connector with Blue Wing-Nut Connector: Black to White wiring (Fig. 7)

- a. Remove WAGO connector for the Black to White wire connection.
- b. Using wire cutters, cut ends of exposed wiring on the Black and White wires.
- c. Using wire strippers, strip wire 5/8" (15.9 mm).
- d. Pre-twisting wiring is unnecessary. Hold stripped wires together with ends even.
- e. Align any frayed strands or conductors.
- f. Push wires firmly into connector and screw on connector.

7. Re-install air conditioner plenum.

- a. Install internal blower cover with (6) fasteners previously removed.
- b. Install the plenum with (4) fasteners previously removed.
- c. Install both filters and grills.

8. Turn on the lithium battery system:

- a. Press and release the self-locking switch.
- b. Next press and hold the self-resetting switch for 3 to 5 seconds to turn on the battery.
- c. To turn on 12V power, press and release the momentary switch located on the left side of the step riser by the sliding door. Note that the red light by switch illuminates when the 12V power is active.
- d. Turn on Inverter by pushing button on Inverter remote switch. Green light will turn on the remote switch when inverter is on.
- e. Repair is complete.

Jayco's sole obligation under our limited warranty is to repair or replace defective materials and/or workmanship deemed our responsibility as determined by Jayco in our sole discretion. Jayco reserves the right to use new and/or remanufactured parts or materials of similar quality to complete any work, and to make parts and/or design changes as appropriate without notice to anyone. Jayco designs and/or materials changes are done without obligation to incorporate such changes in previously manufactured product. Jayco makes every reasonable effort to ensure field remedies will not adversely affect performance and/or safety of the unit. This field remedy is not intended to extend to future performance of this RV, or any of its materials, components or parts beyond the standard warranty period. The RV owner's obligation to notify Jayco, or one of its independent, authorized dealers, of a claimed defect does not modify any obligation placed on the RV owner to contact Jayco directly when attempting to pursue remedies under state or federal law.

903 South Main Street • P.O. Box 460 • Middlebury, IN 46540