



Revision 1 June 2022

Dealer Service Instructions for:

Customer Satisfaction Notification Y54 Missing Options

NOTE: Revised LOP in the time allowance section

Remedy Available

2020 - 2021 (DT) Ram 1500 Pickup

NOTE: Some vehicles above may have been identified as not involved in this campaign and therefore have been excluded from this campaign.

IMPORTANT: Some of the involved vehicles may be in dealer new vehicle inventory. Dealers should complete this campaign service on these vehicles before retail delivery. Dealers should also perform this repair on vehicles in used vehicle inventory and those vehicles in for service. Involved vehicles can be determined by using the VIP inquiry process.

Subject

Various vehicle options on about 151 of the above vehicles may not have been installed during the manufacturing process.

Repair

Locate the VIN on page numbers 4 - 8 to identify which sales code options need to be installed.

Repair [Continued]

Please reference the I-Sheet that is included with the part for the installation procedure on parts not mentioned below.

1. Graphics Installation

Please reference the section below for the specific installation instructions.

A. Rebel Quarter Panel Decals Installation Procedure**B. Rebel Hood Decal Installation Procedure****C. Built to Serve Flag Decals Installation Procedure****2. Spray-in Bedliner Process**

The vehicle will be sent to a LINE-X dealer for installation of a LINE-X Premium spray-in bedliner. LINE-X is the only supplier of bedliner material authorized by FCA US LLC to properly remedy the vehicles in this campaign.

Dealers will sublet the installation of a LINE-X Premium spray-in bedliner to their nearest LINE-X dealer. FCA has determined that the LINE-X Premium product meets FCA standards for materials and spray thickness.

Note: The Premium LINE-X product is the only one approved by FCA, regardless of other products that LINE-X offers.

The dealer will coordinate the installation date with the vehicle owner and LINE-X dealer. The installation will take 24 hours, and alternate transportation for the vehicle owner should be provided. If the distance to the nearest LINE-X dealer is beyond what the FCA dealer can reasonably provide transportation for, the vehicle may be towed.

Alternate Transportation

Dealers should attempt to minimize customer inconvenience by placing the owner in a loaner vehicle if inspection determines that installation of a spray-in bedliner is required. The LINE-X process takes approximately 24 hours to complete.

CSN Y54 DT Missing Upfit Option:

VIN List	Spray-in Bedliner	Under Rail Box Bedliner	Cargo Tie Down (5'7" Box)	Cargo Tie Down (6'4" Box)	Chrome Bodyside Moldings (5'7" Box)	Chrome Bodyside Moldings (6'4" Box)	Rebel Hood Decal	Rebel Exterior Side Graphics	Lockable Storage Console	US Flag Decal	Bed Step	Mopar Trailer Camera Wiring (No Camera)
	XMF	XME	CL2 5'7"	CL2 6'4"	MJB 5'7"	MJB 6'4"	MYA	MPC	CNA	MPQ	MD1	XFQ
1C6RREFT9LN404974	X		X								X	
1C6RREHM0MN502637	X				X							
1C6RREHM8MN501459	X				X							
1C6RREHMXLN405413	X				X							
1C6RREHT3LN406376	X				X							
1C6RREHT8LN373469	X				X							
1C6RREHT8LN398369	X		X		X							
1C6RREHT9LN373903	X				X							
1C6RREHT9MN502904	X				X							
1C6RREHT9MN503521	X				X							
1C6RREHTXLN406505	X				X							
1C6RREJT3LN401852	X		X								X	
1C6RREMM9MN673439												X
1C6SRECG1LN386009		X										
1C6SRECG1LN386124		X										
1C6SRECG1LN386205		X										
1C6SRECG2LN386391		X										
1C6SRECG4LN386215		X										
1C6SRECG5LN385977		X										
1C6SRECG6LN386023		X										
1C6SRECG6LN386149		X										
1C6SRECG7LN386225		X										
1C6SRECG8LN386086		X										
1C6SRFBT6LN403360	X			X							X	
1C6SRFEM0MN653862							X	X				
1C6SRFET5LN418668							X					
1C6SRFFT0LN366543	X								X	X		
1C6SRFFT0MN559082									X	X		
1C6SRFFT3LN365998	X									X		
1C6SRFFT4LN368098	X		X						X	X		
1C6SRFFT6LN366529										X		
1C6SRFFT6LN408407	X		X						X	X		
1C6SRFFT7LN410716	X		X						X	X		
1C6SRFFT8LN366659	X								X	X		

CSN Y54 DT Missing Upfit Options

	Spray-in Bedliner	Under Rail Box Bedliner	Cargo Tie Down (5'7" Box)	Cargo Tie Down (6'4" Box)	Chrome Bodyside Moldings (5'7" Box)	Chrome Bodyside Moldings (6'4" Box)	Rebel Hood Decal	Rebel Exterior Side Graphics	Lockable Storage Console	US Flag Decal	Bed Step	Mopar Trailer Camera Wiring (No Camera)
VIN List	XMF	XME	CL2 5'7"	CL2 6'4"	MJB 5'7"	MJB 6'4"	MYA	MPC	CNA	MPQ	MD1	XFQ
1C6SRFHTXMN505382	X		X		X							
1C6SRFHTXMN525163	X				X							
1C6SRFHTXMN558227	X				X						X	
1C6SRFJM9LN404822	X										X	
1C6SRFJT0MN508463									X			
1C6SRFJT1LN415630	X										X	
1C6SRFJT2MN508271									X			
1C6SRFJT6MN509763									X			
1C6SRFJT7MN530704									X			
1C6SRFJT7MN548572									X			
1C6SRFJT8MN583265	X		X									
1C6SRFJT9MN508851									X			
1C6SRFJTXLN402973	X		X								X	
1C6SRFJTXMN506977									X			
1C6SRFKM7MN688886												X
1C6SRFKT1LN412371	X										X	
1C6SRFKT2LN412718	X		X								X	
1C6SRFKT2MN684123												X
1C6SRFKT4MN673074												X
1C6SRFKT4MN673236												X
1C6SRFKT7MN673313												X
1C6SRFKT8MN658271												X
1C6SRFLM2LN419630	X						X					
1C6SRFLM5MN704498							X	X				
1C6SRFLM7LN418912	X						X					
1C6SRFLT0LN413624	X										X	
1C6SRFLT0MN766981							X	X				
1C6SRFLT2MN684248												X
1C6SRFLT3LN408353	X						X	X				
1C6SRFLT3MN657866												X
1C6SRFLT3MN813064								X				
1C6SRFLT5LN420665	X						X					
1C6SRFLT6MN568678	X											
1C6SRFLT7LN407450	X						X				X	
1C6SRFLT7LN411059	X						X	X				
1C6SRFLT7LN412244	X										X	
1C6SRFLT7MN525953							X	X				

CSN Y54 DT Missing Upfit Options

	Spray-in Bedliner	Under Rail Box Bedliner	Cargo Tie Down (5'7" Box)	Cargo Tie Down (6'4" Box)	Chrome Bodyside Moldings (5'7" Box)	Chrome Bodyside Moldings (6'4" Box)	Rebel Hood Decal	Rebel Exterior Side Graphics	Lockable Storage Console	US Flag Decal	Bed Step	Mopar Trailer Camera Wiring (No Camera)
VIN List	XMF	XME	CL2 5'7"	CL2 6'4"	MJB 5'7"	MJB 6'4"	MYA	MPC	CNA	MPQ	MD1	XFQ
1C6SRFMT5MN556911									X	X		
1C6SRFPT0MN541437	X					X						
1C6SRFPT4LN387684	X			X		X						
1C6SRFPT6LN388416	X					X						
1C6SRFPT6MN627724												X
1C6SRFPT7MN658254												X
1C6SRFPT8LN388742	X					X						
1C6SRFPT9MN684192												X
1C6SRFPTXLN388712	X			X		X						
1C6SRFRT2MN568135	X			X								
1C6SRFSM8MN658277												X
1C6SRFLT9MN657886							X	X				
1C6SRFLTXLN414800	X						X					

Service Procedure**A. Rebel Quarter Panel Decals Installation Procedure**

1. Remove any dirt and debris, Prep install area with isopropyl alcohol. Ensure to wipe down entire quarter panel area. From taillight to gas cap.
2. After prepping hood, Utilize a infrared temperature gun to record the hood temperature. This temperature must be between 70-98 degrees Farenheit.



3. Retrieve rebel conventional bed quarter panel graphic.
4. Peel rear (non-see-through) carrier off with a partner and spray entire graphic area with soap and water mixture.
5. Ensure full coverage of graphic.



Service Procedure [Continued]

6. Cover panel install area with soap and water mixture.
7. Mock up graphic to quarter panel, Carrier will net to the wheel flare. And off the bottom character line.



8. Ensure that the carrier follows the bottom unit character line, and the character line around the taillight.



Service Procedure [Continued]

9. Add a layer of soap and water mixture to the entirety of graphic. Ensure to “Lock Down” graphic by squeegeeing across the top portion first.
10. Begin the squeegeeing process from the center of the graphic. Ensure to work water fully outwards. Repeat squeegee process three times total.

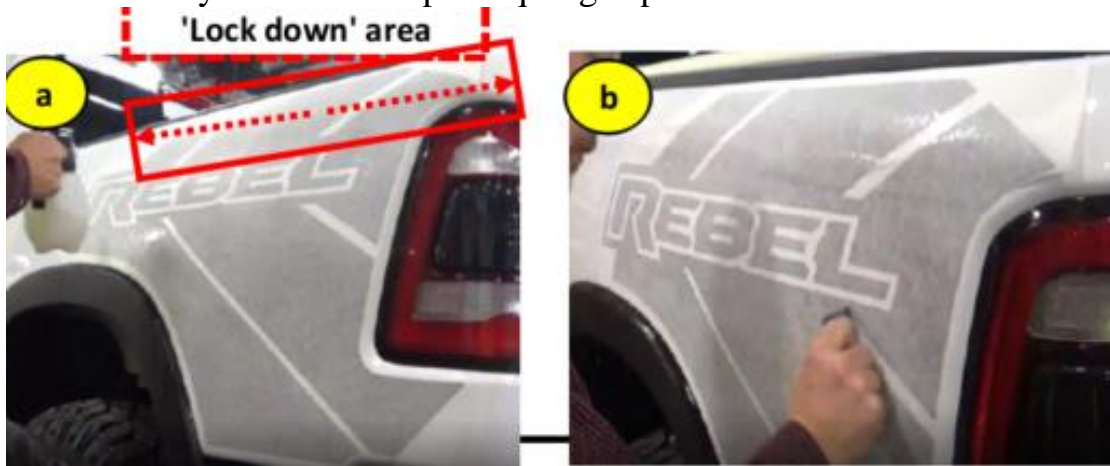

11. Beginning on the side closer to the front end of the bedding. Carefully fully remove carrier. Check install area for any water bubbles or lifts.



Service Procedure [Continued]

12. Complete graphic post-heating process per hood graphic post-heating process. (WI 1552).
13. Ensure to squeegee/bleed out any water bubbles. And squeegee down any lifts.

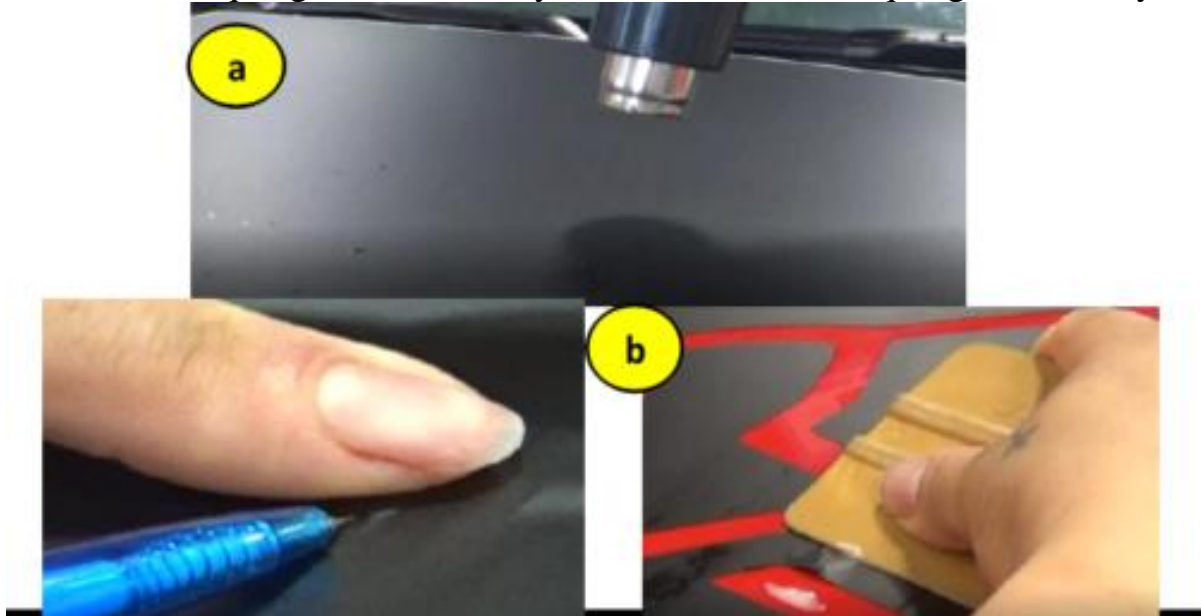

14. The Rambox style quarter panel decal will be separated before install.
15. The separated top edge will be placed on the “Box” covering.

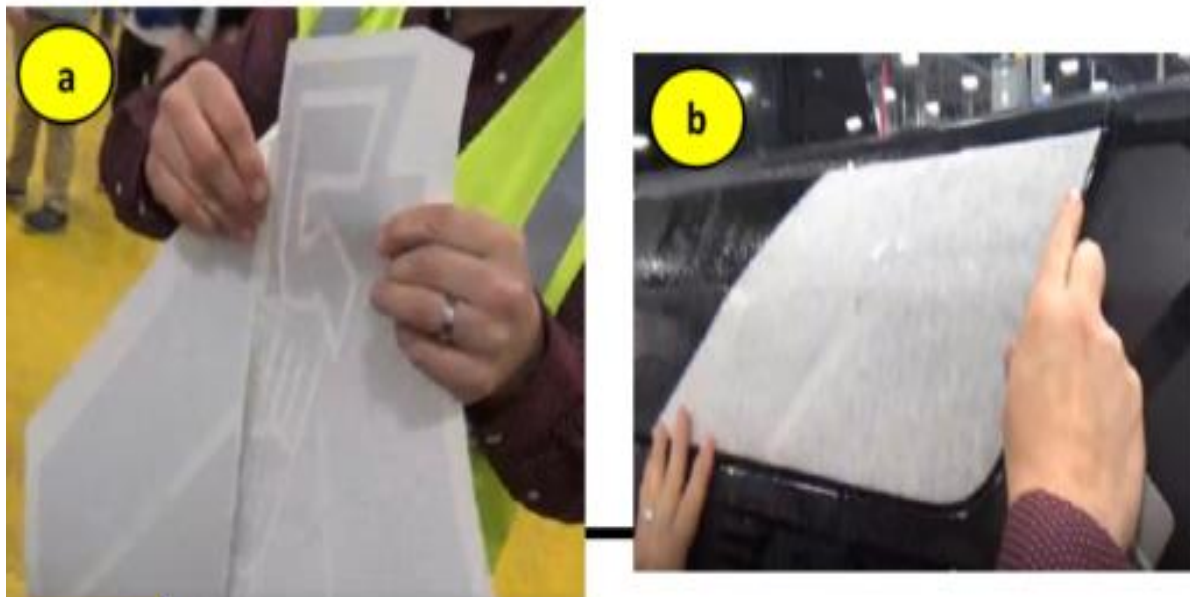

Service Procedure [Continued]

16. Align separated rambox graphic section by utilizing the squeegee between the box edging. Graphic will follow the rambox corner edge.
17. Follow graphic process for squeegeeing, post-heating and final install steps.



18. After post-heating is completed. Wipe down the graphic with isopropyl alcohol. Inspect both driver and passenger side for any defects.



Service Procedure [Continued]

B. Rebel Hood Decal Installation Procedure

1. To remove dirt and debris. Prep install area with 72/25 alcohol mixture.
2. After prepping hood. Utilize a infrared temperature gun to record the hood temperature. This temperature must be between 70-90 degrees Fahrenheit.

a



b



Service Procedure [Continued]

3. The hood graphic locating templates will now be placed on the hood. Netting off of the rebel plastic trim.
4. Ensure that the templates are flush with the rebel hood scoops.

a



b



5. After confirming that the template is in the correct position. 1” masking tape will be utilized to ensure templates stay in place.

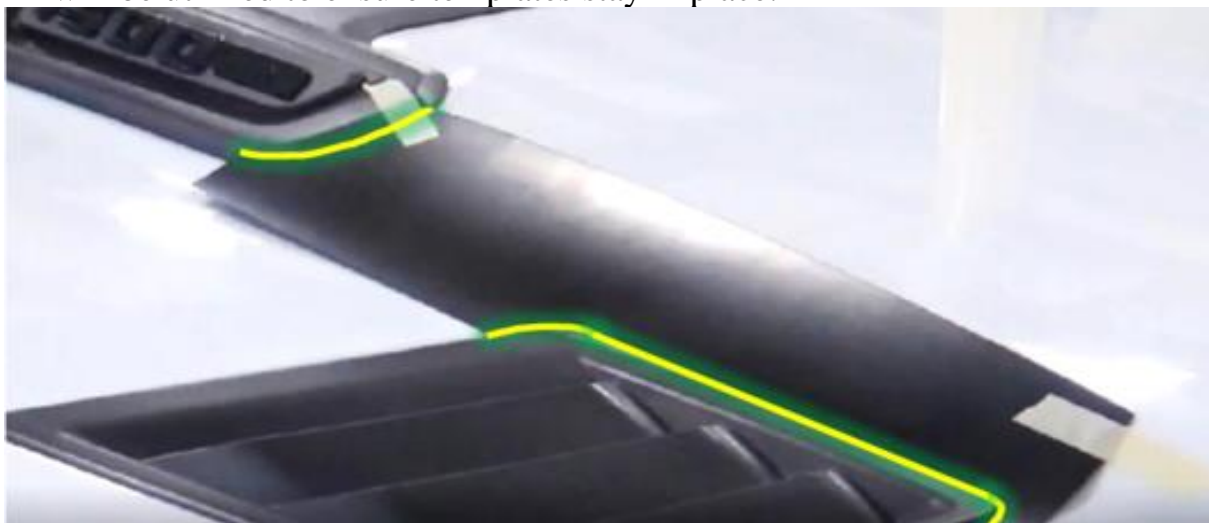

Service Procedure [Continued]

6. Retrieve rebel hood graphic, peel rear (non-see-through) carrier off with a partner, and spray entire graphic area with soap and water mixture. Ensure full coverage of graphic.



7. Cover install area of hood with soap and water mixture.
8. With partner carefully place graphic on hood with the see-through carrier faced up.



Service Procedure [Continued]

9. Graphic will be aligned to the front scoop trim edges.
10. Ensure graphic is also parallel with the inner edges of the hood locating fixtures.



11. Add a layer of soap and water mixture to entirety of graphic.
12. Follow Rebel graphic squeegee methodology for “Lock Down Process.”



Service Procedure [Continued]

13. Once you work your way to the bottom half of the graphic. There will be two striations to tear on both sides.
14. This is done to be able to shift the bottom half of the graphic to ensure alignment.



15. Repeat “Lock Down” process two more times (Three in total) Ensure to re-apply soap and water mixture between each step.
ALERT: Always press towards the edges of the graphics when squeegeeing. Failure to do so can cause water bubble build-up under the graphic. Ensure to NOT squeegee past the edges of the carrier.



Service Procedure [Continued]

- 16. With partner slowly begin peeling off the top layer of the carrier.
- 17. Inspect graphic for any water bubbles trapped.
- 18. On larger clusters of water bubbles, utilize the bubble-pricking tool to release the water, and squeegee out the water.



1&2) Follow Graphic handheld heat gun post-heat process requirements for squeegeeing, post-heating, and final install steps.



Service Procedure [Continued]**C. US Flag Decals Installation Procedure****Instruction Sheet Built to Serve Flag Decals for DT Ram Trucks Left-hand 68500061AA and Right-hand 6800062AA**

1. **Defect Removal.** Remove any dirt nibs or defects in the paint that would result in objectionable read-through defects after decal is applied.
2. **Body Surface.** Body surface temperature must be a minimum of 70°F during decal application to ensure conformability and initial adhesive bond.
3. **Alcohol Wipe.** Wipe the same body surface with a clean lint-free cloth moistened with isopropyl alcohol to remove contaminants.
4. **Dry Wipe.** Wipe the same body surfaces as in step 3 with a clean, dry lint-free cloth to remove remaining haze.
5. **Wetting Solution.** Mix three or four drops of liquid soap (Unscented Joy dish detergent or Johnson's Baby Shampoo) in spray bottle full of clean water.
6. **Placing Tape to Locate the Decal.** Tape along the top of decal and place it using the dimensions on pages 2-4 according to the box size and style.
7. **Liner Removal.** Flip decal up and remove carefully the liner. Avoid contact with decal adhesive surface. Do not let the decal touch the body surface. Spray exposed adhesive and body surface with the setting solution.
8. **First Squeegee.** Squeegee entire premask surface with a plastic squeegee. Start at center and fan out to the edges using firm, overlapping.
9. **Premask Removal.** Slowly remove premask at 180° directions, (flat to surface). Do not snap it off or remove in a 90° direction, (perpendicular to the surface).
If the decal comes up while removing the premask, there may be too much soap in the wetting solution or the temperature may be below 70°F. Pressurize again with squeegee over the entire decal. Then wait a few minute to allow the adhesive of the decal to increase before removing premask.

Service Procedure [Continued]

10. **Second Squeegee.** Squeegeeing after premask removal may be necessary in certain areas. Work bubbles out to the nearest edge or use air release tool or pin and re-squeegee that area to ensure proper adhesion.
11. **Inspection.** Dry off vehicle and inspect for any remaining bubbles. Repeat on opposite side.
12. **Postal Application.** Allow the vehicle to remain 70°F for at least fifteen minutes before taking outside in freezing conditions, Do not power wash decal area for 72 hours.

Service Procedure [Continued]

DT BUILT TO SERVE DECALS POSITION *NOTE STARS ARE TOWARDS THE FRONT OF THE VEHICLE

5'7" BOX LH

5'7" BOX RH

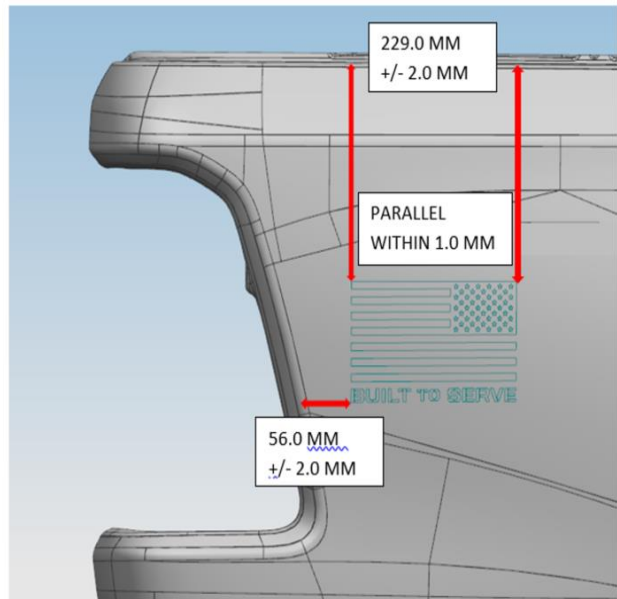
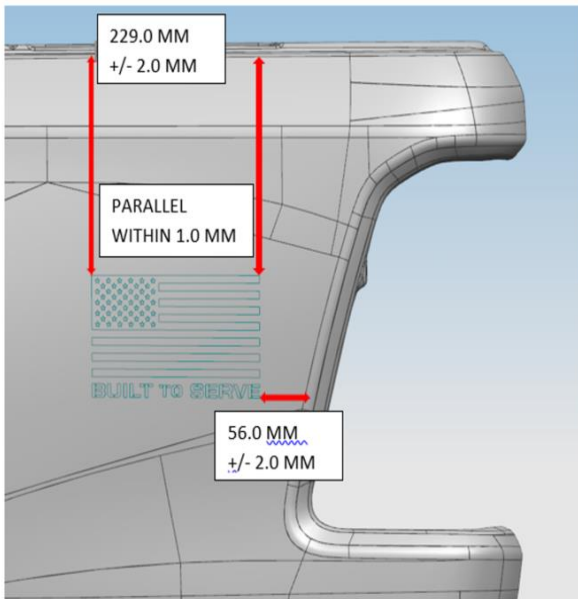

DT BUILT TO SERVE DECALS POSITION *NOTE STARS ARE TOWARDS THE FRONT OF THE VEHICLE

5'7" BOX W/RAM BOX LH

5'7" BOX W/RAM BOX RH

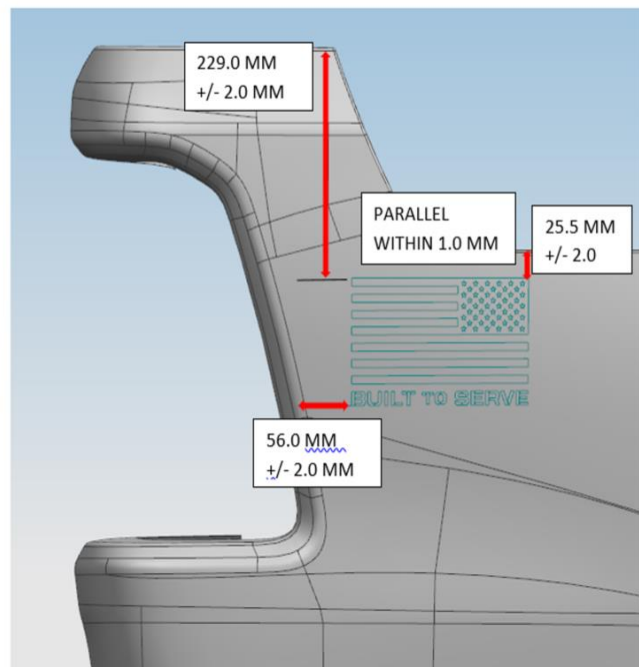
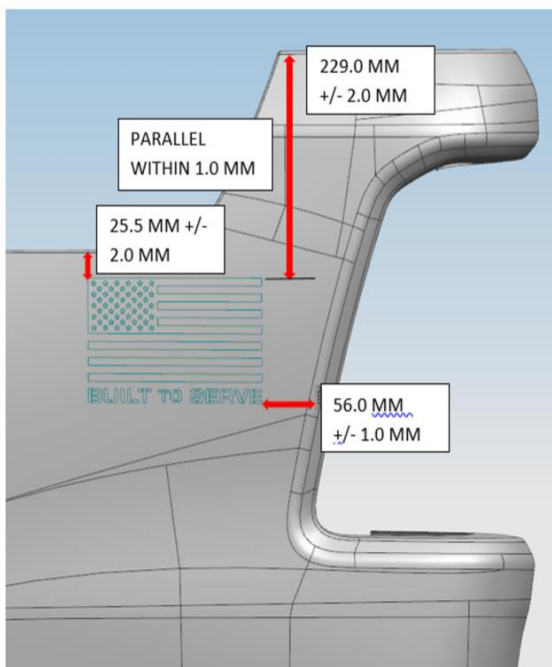

Service Procedure [Continued]

DT BUILT TO SERVE DECALS POSITION *NOTE STARS ARE TOWARDS THE FRONT OF THE VEHICLE

6'4" BOX LH

6'4" BOX RH

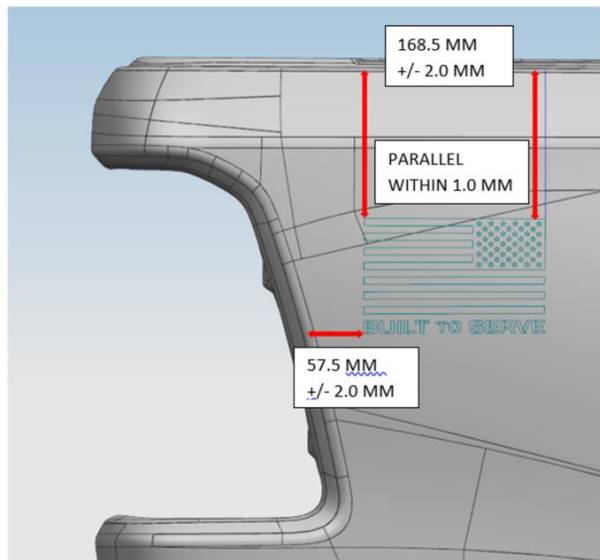
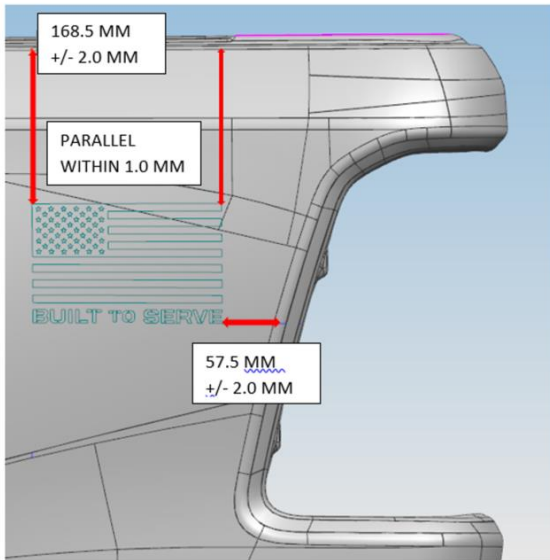

Completion Reporting and Reimbursement

Claims for vehicles that have been serviced must be submitted on the DealerCONNECT Claim Entry Screen located on the Service tab. Claims paid will be used by FCA to record Customer Satisfaction Notification service completions and provide dealer payments.

Use the following labor operation numbers and time allowances:

	<u>Labor Operation Number</u>	<u>Time Allowance</u>
*Installation of LINE-X Premium spray-in Bedliner	23-Y5-41-82	0.0 hours
*Sublet Process Allowance	85-33-33-33	0.3 hours
	<u>Labor Operation Number</u>	<u>Dollar Allowance Up to:</u>
<u>*Sublet Operations</u>		
*Sublet to LINE-X for Premium spray-in bedliner - labor and materials	97-75-65-55	\$475.00
*Towing allowance	95-23-86-51	\$1000.00
Install Mopar Under Rail Box Bedliner	23-Y5-41-83	0.3 hours
Install Mopar 4 Adjust Cargo Tie Hooks	23-Y5-41-84	0.3 hours
Install Chrome Bodyside Moldings	23-Y5-41-85	0.4 hours
Install “Rebel” Hood Decal	23-Y5-41-86	0.5 hours
Install ‘Rebel” Exterior Graphics	23-Y5-41-87	0.3 hours
Install Lockable Console Storage	23-Y5-41-88	0.7 hours
Install US Flag Decal (Left & Right)	23-Y5-41-89	0.5 hours
Install Bed Step	23-Y5-41-8A	0.4 hours
Install Trailer Camera Wiring	23-Y5-41-8B	0.7 hours

NOTE: See the Warranty Administration Manual, Recall Claim Processing Section, for complete claim processing instructions.

Dealer Notification

To view this notification on DealerCONNECT, select “Global Recall System” on the Service tab, then click on the description of this notification.

Owner Notification and Service Scheduling

All involved vehicle owners known to FCA are being notified of the service requirement by mail. They are requested to schedule appointments for this service with their dealers. A generic copy of the owner letter is attached.

Vehicle Lists, Global Recall System, VIP and Dealer Follow Up

All involved vehicles have been entered into the DealerCONNECT Global Recall System (GRS) and Vehicle Information Plus (VIP) for dealer inquiry as needed.

GRS provides involved dealers with an updated VIN list of their incomplete vehicles. The owner’s name, address and phone number are listed if known. Completed vehicles are removed from GRS within several days of repair claim submission.

To use this system, click on the “**Service**” tab and then click on “**Global Recall System.**” Your dealer’s VIN list for each campaign displayed can be sorted by: those vehicles that were unsold at campaign launch, those with a phone number, city, zip code, or VIN sequence.

Dealers should perform this repair on all unsold vehicles before retail delivery. Dealers should also use the VIN list to follow up with all owners to schedule appointments for this repair.

VIN lists may contain confidential, restricted owner name and address information that was obtained from the Department of Motor Vehicles of various states. Use of this information is permitted for this notification only and is strictly prohibited from all other use.

Additional Information

If you have any questions or need assistance in completing this action, please contact your Service and Parts District Manager.

Customer Service / Field Operations
FCA US LLC

This notice applies to your vehicle,

[Model Year and Model]

VIN XXXXXXXXXXXXXXXXXXXX

Y54

LOGO

VEHICLE PICTURE

YOUR SCHEDULING OPTIONS

- 1. RECOMMENDED OPTION**
Call your authorized Chrysler / Dodge / Jeep® / RAM Dealership
- 2. Call the FCA Recall Assistance Center at 1-800-853-1403.** An agent can confirm part availability and help schedule an appointment
- 3. Visit recalls.mopar.com, scan the QR code below, or download the Mopar Owner's Companion App.**

QR Code

Get access to recall notifications, locate your nearest dealer, and more through this website or Mopar Owner's Companion App. You will be asked to provide your Vehicle Identification Number (VIN) to protect and verify your identity.

DEALERSHIP INSTRUCTIONS

Please reference CSN Y54.

CUSTOMER SATISFACTION NOTIFICATION

Missing Options

Dear [Name],

At FCA US LLC, we recognize that the success of our business depends on the satisfaction of our customers. We are constantly monitoring the quality of our products and looking for opportunities to improve our vehicles even after they are sold. Because your long-term satisfaction is important to us, we are contacting you on important improvements we would like to make to your vehicle ^[1]. This will be done at no charge to you.

We are recommending the following improvements be performed on certain [2020 and 2021 Model Year (DT) Ram 1500 Pickup] vehicles.

WHY DOES MY VEHICLE NEED REPAIRS?

Your vehicle may have been built without some of the specified options during the manufacturing process.

HOW DO I RESOLVE THIS CUSTOMER SATISFACTION NOTIFICATION?

FCA US will repair your vehicle free of charge (parts and labor). To do this, your dealer will review the options list that are specified for your vehicle and install any missing options as required. The estimated repair time will vary depending on the options that need to be installed most options take about an hour. In addition, your dealer will require your vehicle for proper check-in, preparation, and check-out during your visit, which may require more time. Your time is important to us, so we recommend that you schedule a service appointment to minimize your inconvenience. Please bring this letter with you to your dealership.

**TO SCHEDULE YOUR FREE REPAIR,
CALL YOUR CHRYSLER, DODGE, JEEP OR RAM DEALER TODAY**

WHAT IF I ALREADY PAID TO HAVE THIS REPAIR COMPLETED?

If you have already experienced this specific condition and have paid to have it repaired, you may visit www.fcarecallreimbursement.com to submit your reimbursement request online. ^[2] Once we receive and verify the required documents, reimbursement will be sent to you within 60 days. If you have had previous repairs performed and/or already received reimbursement, you may still need to have the repair performed.

We apologize for any inconvenience, but are sincerely concerned about your satisfaction. Thank you for your attention to this important matter.

Customer Assistance/Field Operations
FCA US LLC



Mr. Mrs. Customer
1234 Main Street
Hometown, MI 48371

[1] If you no longer own this vehicle, please help us update our records. Call the FCA Recall Assistance Center at 1-800-853-1403 to update your information.

[2] You can also mail in your original receipts and proof of payment to the following address for reimbursement consideration: FCA Customer Assistance, P.O. Box 21-8004, Auburn Hills, MI 48321-8007, Attention: Recall Reimbursement.