



## STAR ONLINE PUBLICATION



**Case Number:** S2108000270 Rev A

**Release Date:** June 2022

**Symptom/Vehicle Issue:** Sky Slider Power Top Does Not Operate. New Power Top Motors Inoperative

**Customer Concern/Technician Observation:** Owner complains the sky slider top does not open. Technician finds the power motors do not operate, power top motors may have been replaced and will not calibrate.

**Repair Procedure:** The cluster provides warning messages when ignition is first turned "on" and or during a power top open/close request. If there are no EVIC messages (see list below), check to see if the rear wiper motor will turn on. If the rear wiper does not function, check the BCM roof sense ground circuit, Pg 1-2.

### **EVIC Power Top Status Messages:**

If "OBSTRUCTED", the IC shall display POWER TOP-NOT AVAILABLE-OBSTACLE DETECTED.

If "SPEED\_INH"(Speed above 60 MPH) the IC shall display POWER TOP-NOT AVAILABLE-SPEED TOO HIGH

If "COLD\_INH" (Temperature below -4F), the IC shall display POWER TOP-NOT AVAILABLE-TEMP TOO LOW

### **EVIC Power Top Calibration Status Messages:**

If "PT\_UNCAL"(Power Top not calibrated), the IC shall display POWER TOP-NOT AVAILABLE-PRESS AND HOLD TO CALIB

If "PT\_CAL\_IN\_PROG" (Power Top calibration in progress), the IC shall display POWER TOP-NOT AVAILABLE-CALIB IN PROGRESS

If "PT\_CAL\_INTERRUPT"(Power Top calibration interrupted) , the IC shall display POWER TOP- CALIBRATION INCOMPLETE

This document does not authorize warranty repairs. This communication documents a record of past experiences. STAR Online does not provide any conclusions about what is wrong with the vehicle. Rather, it captures all previous cases known that appear to be similar or related to the vehicle symptom / condition. You are the expert, and you are responsible for deciding on the appropriate course of action.

**Contact STAR Center, or your Technical Assistance Center Via TechCONNECT or eCONTACT ticket if no solution is found**



## STAR ONLINE PUBLICATION



If "PT\_CAL\_COMPLETE" (Power Top calibration successful), the IC shall display  
POWER TOP-CALIB COMPLETE

If "PT\_UNCAL\_ENG\_OFF" (Power Top not calibrated and engine off), the IC shall  
display AUTO POWER TOP-NOT AVAILABLE-PRESS AND HOLD

**<<<Note>>>** Power Top relearn procedure can be initiated by holding the "close" switch for 10 seconds. A customer could induce learn mode and not realize it by accidentally holding the "close" switch for 10 or more seconds. For Power Top Calibration see procedure - 08 - Electrical / 8N - Power Systems / Power Top, Full Open Retractable Roof / Standard Procedure

### Pg 1

Check pin 14, Q997 circuit, C5 connector at the BCM for proper grounding.

This document does not authorize warranty repairs. This communication documents a record of past experiences. STAR Online does not provide any conclusions about what is wrong with the vehicle. Rather, it captures all previous cases known that appear to be similar or related to the vehicle symptom / condition. You are the expert, and you are responsible for deciding on the appropriate course of action.

**Contact STAR Center, or your Technical Assistance Center Via TechCONNECT or eCONTACT ticket if no solution is found**



# STAR ONLINE PUBLICATION

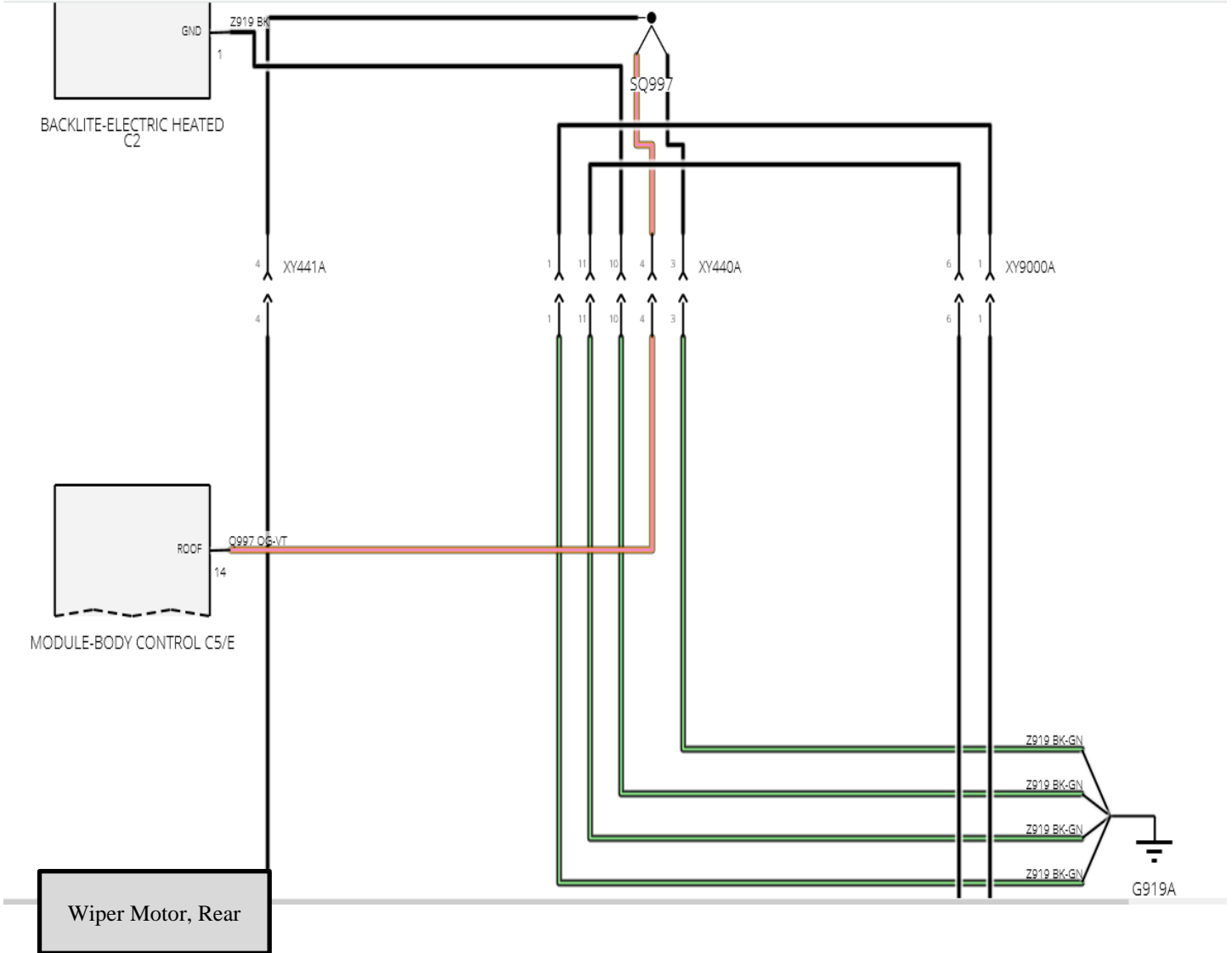

Pg2

This document does not authorize warranty repairs. This communication documents a record of past experiences. STAR Online does not provide any conclusions about what is wrong with the vehicle. Rather, it captures all previous cases known that appear to be similar or related to the vehicle symptom / condition. You are the expert, and you are responsible for deciding on the appropriate course of action.

**Contact STAR Center, or your Technical Assistance Center Via TechCONNECT or eCONTACT ticket if no solution is found**