



Service Bulletin

Bulletin No.: 21-NA-220

Date: September, 2022

TECHNICAL

Subject: Loss of Power, Malfunction Indicator Lamp (MIL) Illuminated, Gauges Inoperative and/or Multiple Warning Lights/Messages Displayed on Driver Information Center (DIC) – Multiple DTCs Set

Brand:	Model:	Model Year:		VIN:		Engine:	Transmission:
		from	to	from	to		
Chevrolet	Malibu	2016	2022	—	—	1.5L Turbo (LFV)	—

Involved Region or Country	North America, Israel, Palestine
Condition	<p>Some customers may comment on one or more of the following conditions:</p> <ul style="list-style-type: none">• Loss of power• MIL illuminated• Gauges dropping out• Multiple warning lights and/or messages <p>Technicians may find one or more of the following DTCs stored in the Engine Control Module (ECM):</p> <ul style="list-style-type: none">– P0700, P150C, P15FD, P2544, P308D, U0073, U0101, U0129, U0140, U0146, U183A, U18D5, U18D7, U2413, U0121, U0100, U0401, U0131
Cause	This condition may be caused by high resistance on the HSCAN BUS circuits 2500/2501 between the Electronic Brake Control Module (EBCM) and the Power Steering Control Module (PSCM).

Correction

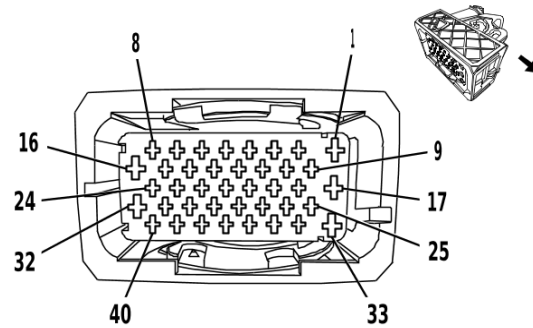

2220548

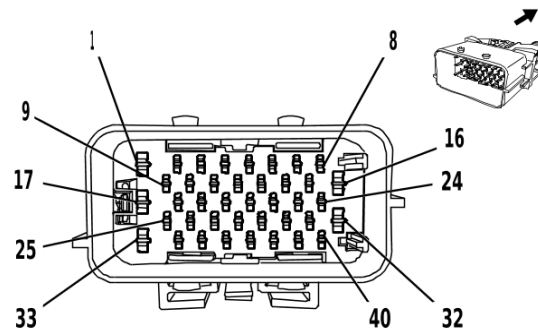

2339640

With the battery disconnected, verify the resistance of the HSBUS circuits across 2500, 2501 splitting the circuit at the X115 electrical connector. Refer to Master Electrical Component List in SI. Looking for any unwanted resistance (ex. 126.7 or something other than in the range of 120 ohms). If stray resistance is traced down to one of the module connector terminals, verify terminal tension and ensure there is no damage to the terminal. If the terminal is good, then apply dielectric grease to the terminals.

If the terminals are damaged or have poor terminal tension, replace with terminated leads at the suspect module connector and apply dielectric grease to the connector.

Important: Service agents must comply with all International, Federal, State, Provincial, and/or Local laws applicable to the activities it performs under this bulletin, including but not limited to handling, deploying, preparing, classifying, packaging, marking, labeling, and shipping dangerous goods. In the event of a conflict between the procedures set forth in this bulletin and the laws that apply to your dealership, you must follow those applicable laws.

Service Procedure

1. Disconnect the battery.
2. Disconnect the X115 engine harness electrical connector.
 - ⇒ Verify the resistance of the HSBUS circuits across 2500, 2501 splitting the circuit at the X115 electrical connector.
3. Remove the radiator surge tank fastener.
4. Disconnect the engine wiring harness clip from the surge tank.
5. Reposition surge tank aside to gain access to the EBCM.



5905953

6. Disconnect the K17 EBCM electrical connector.

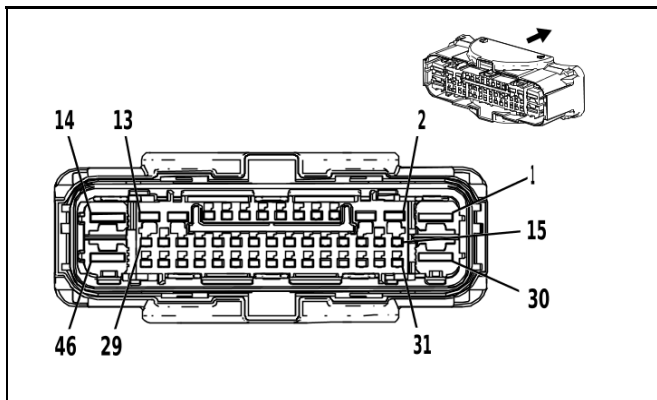

3960473

7. Inspect for terminal tension/damage at the wiring harness for circuits 2500/2501.
⇒ If improper terminal tension is found, replace terminals with terminated leads per SI.
8. Verify the resistance of the HSBUS circuits across 2500, 2501.
9. Add dielectric grease to the terminals.
10. Connect the EBCM connector.
11. Reposition the surge tank.
12. Install the wiring harness clip onto the surge tank.

13. Install the surge tank fastener. Refer to *Fastener Specifications* in SI.
14. Raise the vehicle.



5905956

15. Disconnect the K43 PSCM electrical connector.

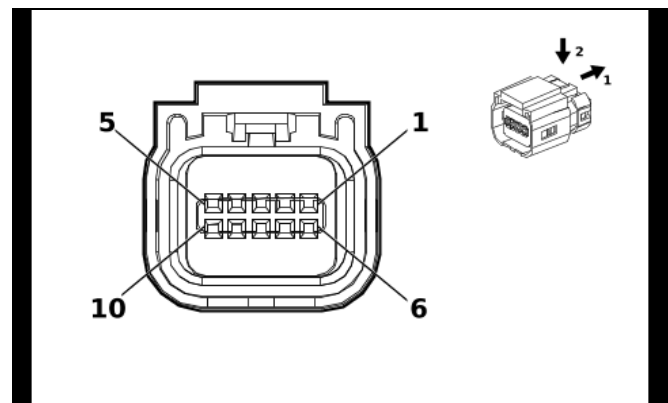

2586629

16. Inspect for terminal tension/damage at the wiring harness for circuits 2500/2501.
⇒ If improper terminal tension is found, replace terminals with terminated leads per SI.
17. Verify the resistance of the HSBUS circuits across 2500, 2501.
18. Add dielectric grease to the terminals.
19. Connect the PSCM electrical connector.

20. Lower the vehicle.
21. Connect the X115 engine harness electrical connector.
22. Connect the battery.

Parts Information

Causal Part	Description	Part Number	Qty
N/A	ACDelco Dielectric Lubricant*	12377900 (U.S.) 10953529 (Canada)	1

*There is enough material to do additional vehicles. Store the remaining material for future use.

Warranty Information

Note: Only use the Labor Operation number that coincides with the repair performed.

For vehicles repaired under the Bumper-to-Bumper coverage (Canada Base Warranty coverage), use the following labor operation. Reference the Applicable Warranties section of Investigate Vehicle History (IVH) for coverage information.

Labor Operation	Description	Labor Time
5486258*	Terminal Testing/Inspection and Dielectric Lubricant Application	1.0 hr
Add	EBCM Terminal Repair	0.5 hr
Add	PSCM Terminal Repair	0.5 hr

*This is a unique Labor Operation for bulletin use only.

Version	3
Modified	Released October 08, 2021 Revised November 05, 2021 – Added DTC U0073 in the Condition section and Israel, Palestine to the Involved Region or Country section. Revised September 02, 2022 – Added the 2016–2018 Model Years and the Important statement above the Service Procedure.

