

September 2, 2022

Version 2

MIL Is ON with DTC P0455

Supersedes 21-007, dated February 6, 2021, see REVISION SUMMARY

AFFECTED VEHICLES

Year	Model	Trim Level	VIN Range
2021	TLX	ALL	ALL
2022	TLX	2WD	19UUB5...NA000001 thru 19UUB5...NA004268
2022	TLX	SH-AWD	19UUB6...NA000001 thru 19UUB6...NA002548
2022	TLX	SH-AWD Type S	19UUB7...NA000001 thru 19UUB7...NA001734

REVISION SUMMARY

American Honda recommends that you review this entire bulletin as it has been revised extensively.

SYMPTOM

The MIL comes on with DTC P0455 (Evaporative Emission [EVAP] System Very Large Leak Detected) stored.

POSSIBLE CAUSE

The fuel main flap unit may have stuck open, causing a DTC to set.

CORRECTIVE ACTION

Inspect the EVAP system (except the main flap unit) for leaks. If the system is OK, replace the fuel filler pipe assembly.

PARTS INFORMATION

Part Name	Part Number	Quantity
Fuel Filler Pipe Assembly	17650-TGV-A03	1
Flange Bolt (10 x 20) (SH-AWD only)	90165-S3V-A00	4
Self-Lock Nut (10 mm) (SH-AWD Only)	90306-TGV-A00	2
Cover Ring Gasket Set (Main)	17046-TGV-A01	1 (If draining the Fuel tank)
Retainer (Natural) (Tokai)	17711-SDC-L01	1
Retainer (Green) (Tokai)	17711-TA0-L01	1

CLIENT INFORMATION: The information in this bulletin is intended for use only by skilled technicians who have the proper tools, equipment, and training to correctly and safely maintain your vehicle. These procedures should not be attempted by "do-it-yourselfers," and you should not assume this bulletin applies to your vehicle, or that your vehicle has the condition described. To determine whether this information applies, contact an authorized Acura automobile dealer.

TOOL INFORMATION

Part Name	Part Number	Quantity
Cam Lock Ring Remover	07AAA-TBAA100	1
Vacuum/Pressure Gauge	07JAZ-001000B	1
Vacuum Pump/Gauge	YA4000A (Snap-On) or equivalent	1

WARRANTY CLAIM INFORMATION

The normal warranty applies.

2WD Models

Operation Number	Description	Flat Rate Time	Defect Code	Symptom Code	Template ID	Failed Part Number
3105H5	Check the EVAP system for leaks and do a vacuum test.	0.8 hr.	03214	03217	B21007C	17060-TGV-A00
D	Replace the fuel filler pipe assembly. (Includes DTC check and clear.)	0.6 hr.				
E	For fuel tank that is more than three fourth full drain and refill - Add	0.4 hr				

SH-AWD Models

Operation Number	Description	Flat Rate Time	Defect Code	Symptom Code	Template ID	Failed Part Number
3105H5	Check the EVAP system for leaks and do a vacuum test.	0.8 hr.	03214	03217	B21007E	17060-TGV-A00
B	For SH-AWD - Add.	1.0 hr.				
D	Replace the fuel filler pipe assembly. (Includes DTC check and clear.)	0.6 hr.				
E	For fuel tank that is more than three fourth full drain and refill - Add	0.4 hr				

Skill Level: Repair Technician

INSPECTION PROCEDURE

1. Connect the i-HDS to the vehicle and confirm DTC P0455 is present.
 - If DTC P0455 is present, go to step 2.
 - If DTC P0455 is not present, this bulletin does not apply. Continue with normal troubleshooting.
2. Check the vacuum at the EVAP canister purge valve using the vacuum pump. Apply about **2 kPa** (0.6 inHg, 15 mmHg) of vacuum to the hose using the vacuum tool.

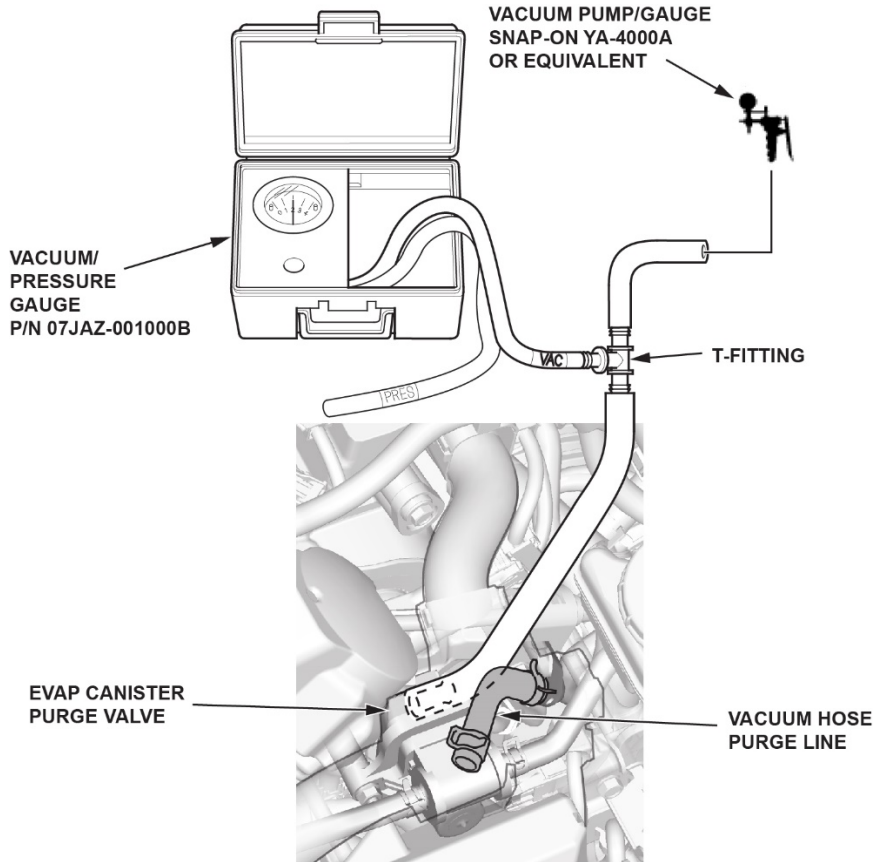

- If the vacuum holds for **1 minute**, continue to step 3.
NOTE: Leave the vacuum hose purge line disconnected.
- If it does not hold for **1 minute**, this bulletin does not apply. Continue with normal system troubleshooting.

3. Check for a poor connection or damage on the EVAP canister purge line between the canister purge valve and the canister. Also check the EVAP canister, the FTP sensor, the EVAP canister vent shut valve, and O-rings for damage.

NOTE: *Vehicles with SH-AWD*: Disconnect the rear stabilizer bar and slide it towards the rear of the vehicle to gain access to the hose. Keep the stabilizer bar disconnected until all checks are completed.

- If conditions are ok and there is no damage, continue to step 4.
- If there is damage to the components or conditions are not ok, this bulletin does not apply. Continue with normal system troubleshooting.

4. Disconnect and check the EVAP canister vent hose for a blockage or restriction.

- If there isn't a blockage or restriction, the system is normal. Continue to step 5.

NOTE: Leave the canister vent hose disconnected.

- If there is a blockage or restriction, this bulletin does not apply. Continue with normal system troubleshooting.

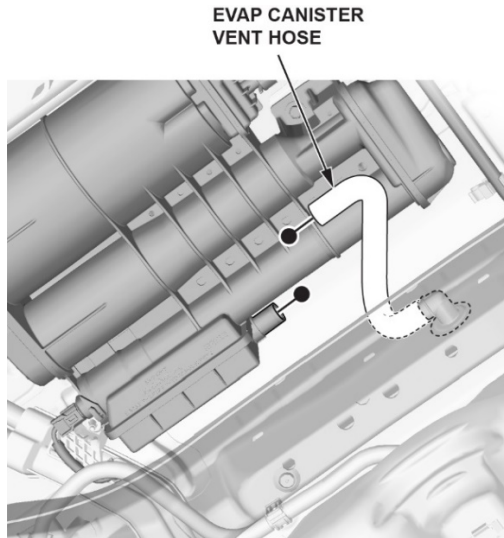

5. Disconnect the fuel vent tube and plug the fuel vent tube and canister vent hose ports with plugs. Then, connect a vacuum pump to the vacuum hose purge line at the EVAP canister purge valve, located in the engine bay.

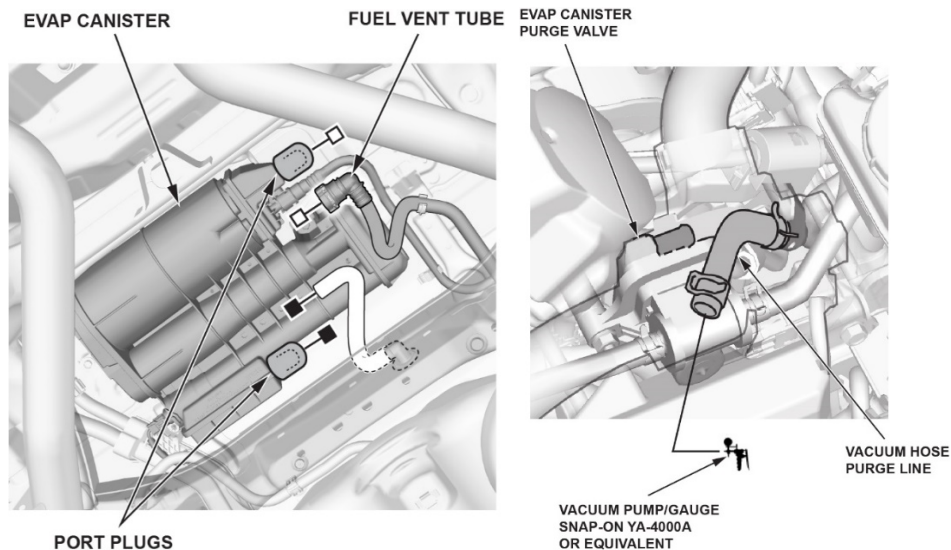

6. Turn the vehicle to the ON position. While watching the FTP sensor voltage in the PGM-FI data list, apply vacuum to the hose until it reads **1.90 V**. Monitor the FTP sensor voltage for **1 minute**.

NOTE: Be careful not to exceed the **1.90 V**. If you do, the FTP sensor may be damaged.

- If the FTP sensor voltage increases more than **0.2 V**, the system is normal. Continue to step 7.
- If it does not, this bulletin does not apply. Continue with normal system troubleshooting.

7. Reconnect the EVAP canister vent hose and keep the fuel vent tube port plugged.
8. Using the i-HDS, go to the following: **PGM-FI > Function Test > EVAP TEST > Single Solenoid.**
9. Select CVS ON and apply vacuum to the hose until it reads **1.90 V**.

NOTE: Be careful not to exceed **1.90 V**. If you do, the FTP sensor may be damaged.

10. Go to the PGM-FI data list and monitor the FTP sensor voltage.
 - If the FTP sensor voltage increases more than **0.2 V**, the system is normal. Go to step 11.
 - If it does not, this bulletin does not apply. Continue with normal system troubleshooting.

NOTE: *Vehicles with SH-AWD*: Reinstall the sway bar and use the new hardware provided.

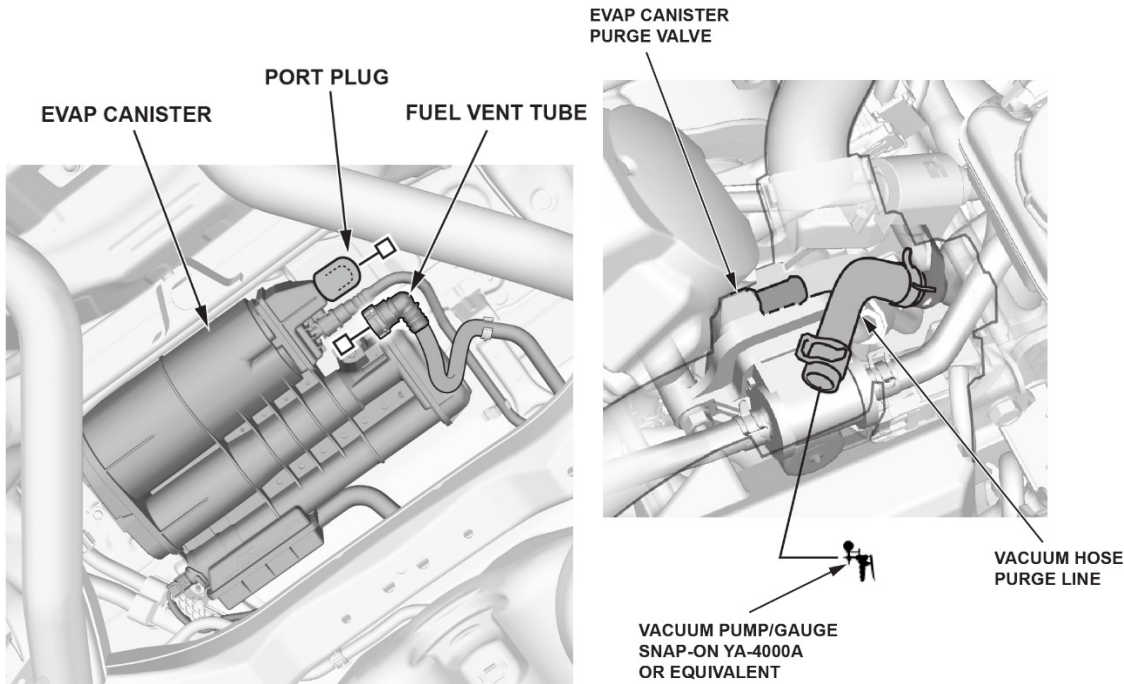

11. Check for a poor connection or damage on the fuel fill pipe and the fuel tank vapor recirculation tube.
 - If the connections are ok and there are no damages, the system is normal. Reconnect the fuel vent tube and the vacuum hose purge line. Go to REPAIR PROCEDURE.
 - If there are any damages or loose connections, this bulletin does not apply. Continue with normal system troubleshooting.

REPAIR PROCEDURE

1. Relieve the fuel pressure.
2. Disconnect the battery.
3. If the fuel tank level is above $\frac{3}{4}$, drain the fuel until the fuel tank is at or below $\frac{3}{4}$.
4. Remove the left rear wheel and inner fender.

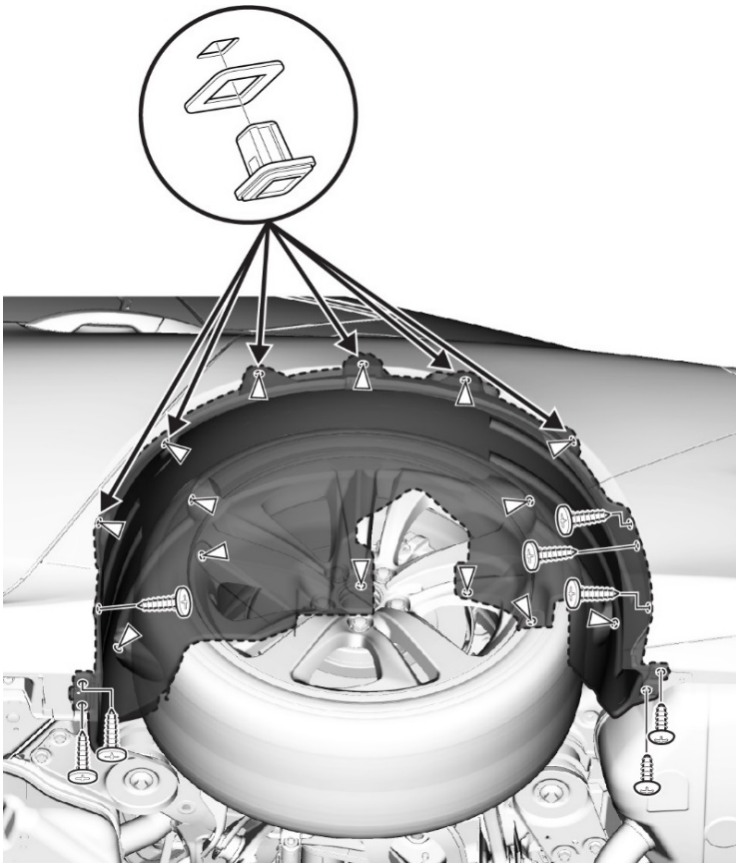

5. Disconnect the connector and remove the two fuel filler neck bolts.



BOLTS

CONNECTOR

- Unclip the fuel filler adapter assembly from around the filler door hinge.



- Pull away the filler neck adapter assembly (no need to fully remove).
- Remove the fuel filler pipe assembly by releasing the retainer tabs on the clips that release them from the locking tabs.

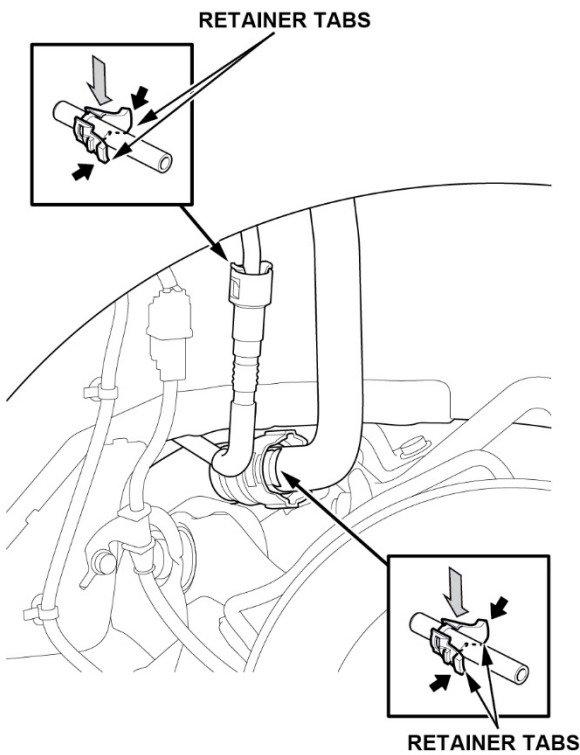

- Install the new fuel filler pipe assembly with the two new must replace clips into the fuel line until a click sound is heard. Then, torque the bolts to **9.5 N.m (7 lb-ft)**.



10. Connect the battery, refill the fuel tank (if previously drained), and install all removed parts.
11. Connect the i-HDS to the vehicle.
12. Check and clear the DTC and do the steering angle neutral position learn.

END