



# TECH EXCHANGE

©2022 YAMAHA MOTOR CORPORATION, U.S.A.

**SUBJECT: 2017 FZ10, 2018~2021 MT-10, AND 2016~2018 YZF-R1S**

**— Revised Oil Pan Tightening Torque and New Oil Pan Gasket**



## INTRODUCTION

### Oil Pan Tightening Torque and Loctite® Application

The Service Manuals for the 2017 FZ-10 (LIT-11616-30-05), 2018~2021 MT-10 (LIT-11616-31-48), 2016 YZF-R1S (LIT-11616-29-36), and 2017~2018 YZF-R1S (LIT-11616-30-62) have been updated to show the revised tightening torque and proper Loctite® application. The Service Manuals in the Knowledge Center on the Yamaha Dealer System (YDS) have been updated to show the correct and complete information. The revised torque value is intended to be used with the superseded oil pan gasket which is intended to reduce the chance of oil weepage.

If you have previously saved copies of the Service Manual to your local computer, check the applicable pages identified in this Technical Exchange to be sure they have the updated information as shown on the following pages. If not, please download the file again and replace your file copies.



Model	Year	Service Manual Number	Chapter	Location	Applicable Page(s)
FZ-10	2017	LIT-11616-30-05	Engine	Oil Pump	5-44, 5-45
				Installing the Oil Pan	5-50
MT-10	2018~2021	LIT-11616-31-48	Engine	Oil Pump	5-44, 5-45
				Installing the Oil Pan	5-50
YZF-R1S	2016	LIT-11616-29-36	Specifications	Tightening Torques	2-15
			Engine	Oil Pump	5-44, 5-45
	2017~2018	LIT-11616-30-62		Engine	Installing the Oil Pan
			Oil Pump		5-44, 5-45
Installing the Oil Pan	5-50				

<b>Incorrect</b>				
Oil pan bolt	M6	3	12 Nm (1.2 m-kgf, 8.7 ft-lbf)	
Oil pan bolt	M6	9	12 Nm (1.2 m-kgf, 8.7 ft-lbf)	

<b>Correct</b>				
Oil pan bolt	M6	12	10 Nm (1.0 m-kgf, 7.2 ft-lbf)	

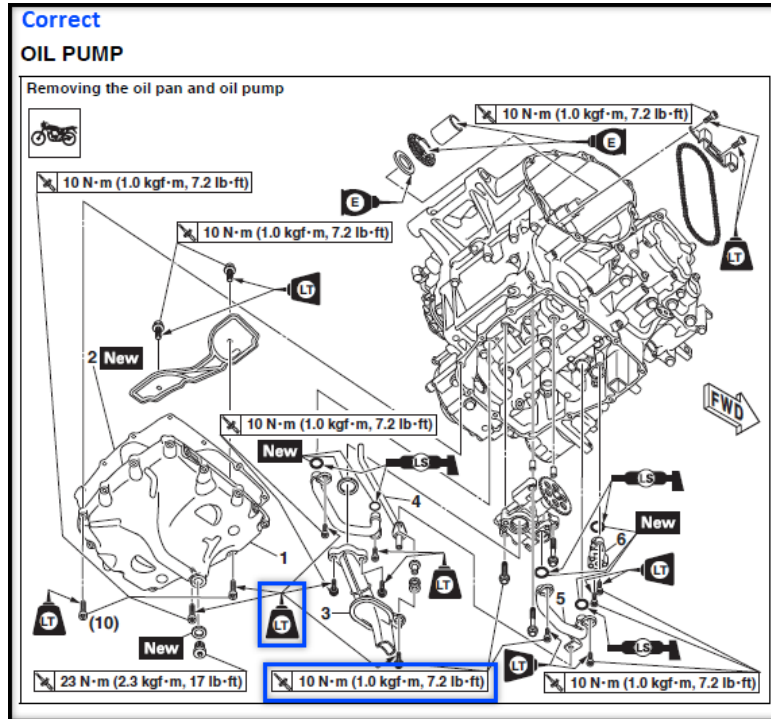

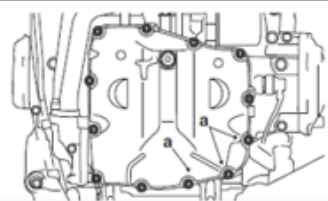
<p><b>Incorrect</b></p> <p><b>INSTALLING THE OIL PAN</b></p> <p>1. Install:</p> <ul style="list-style-type: none"> <li>• Oil pan gasket <b>New</b></li> <li>• Oil pan</li> <li>• Oil pan bolt</li> </ul> <p>2. Tighten:</p> <ul style="list-style-type: none"> <li>• Oil pan bolt</li> </ul> <div style="border: 1px solid black; padding: 5px; margin: 5px 0;">  <p><b>Oil pan bolt</b> 12 Nm (1.2 m-kgf, 8.7 ft-lbf)</p> </div> <p><b>TIP</b></p> <ul style="list-style-type: none"> <li>• Apply locking agent (LOCTITE®) to the bolts installed in the bolt holes marked with arrows "a" on the oil pan.</li> <li>• Tighten the oil pan bolts in stages and in a crisscross pattern.</li> </ul> 	<p><b>Correct</b></p> <p><b>INSTALLING THE OIL PAN</b></p> <p>1. Install:</p> <ul style="list-style-type: none"> <li>• Oil pan gasket <b>New</b></li> <li>• Oil pan</li> <li>• Oil pan bolt (x 12)</li> </ul> <p><b>TIP</b></p> <p>Tighten the oil pan bolts in stages and in a crisscross pattern.</p> <p>2. Tighten:</p> <ul style="list-style-type: none"> <li>• Oil pan bolt</li> </ul> <div style="border: 1px solid black; padding: 5px; margin: 5px 0;">  <p><b>Oil pan bolt</b> 10 N-m (1.0 kgf.m, 7.2 lb-ft) LOCTITE®</p> </div>
---	--

### Oil Pan Gasket Supersession

The parts catalogs in PartsManager Pro™ have been revised to provide the superseded part number for the oil pan gasket (strainer cover gasket).

Part Name	Previous Part Number	New Part Number	Qty
GASKET, STRAINER COVER	2CR-13414-00-00	BX4-13414-00-00	1

**TIP:** The previous part number does not automatically supersede because it continues to be used on other models.