

ADDRESSEES	: Owners and operators
VEHICLE MODEL	: CX45 E and TDX25E
MANUAL CHAPTER	: 02.13H Traction system – traction battery
BULLETIN TYPE	: Service information
DATE	: September 05th, 2022
SUBJECT	: To charge traction batteries with Heliox mobile charger
CONDITIONS	: This service bulletin does not entitle to any reimbursement.

INTRODUCTION

This service bulletin gives instructions on how to charge the traction batteries with the Heliox mobile charger.

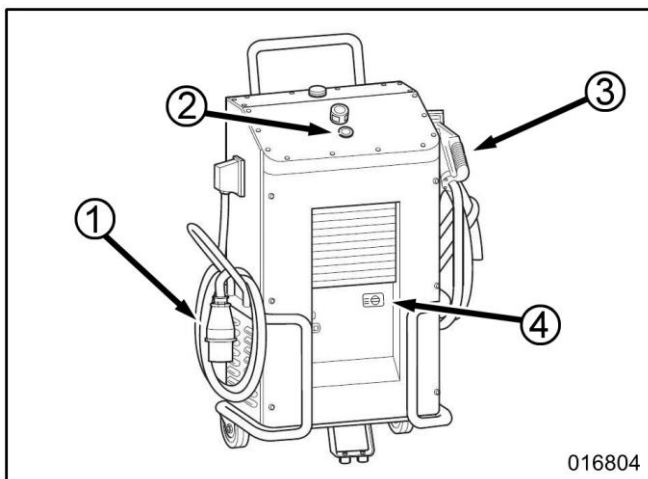

Figure 1: Heliox mobile charger – components

- 1: AC cable
- 2: Stop button with indicator light (LED ring)
- 3: Charging cable
- 4: Current-selector switch

PREPARATIONS

- Park the vehicle on a level floor. Apply the parking brake.
- Switch off the traction system.
- Switch off all systems and turn off the battery isolation switch on the dashboard.
- Put a "DO NOT START" warning message on the instrument panel
- **Read the entire procedure before starting the operations.**



WARNING!

Observe safe shop practices at all times.

Continued on next page.

TO CONNECT MOBILE CHARGER

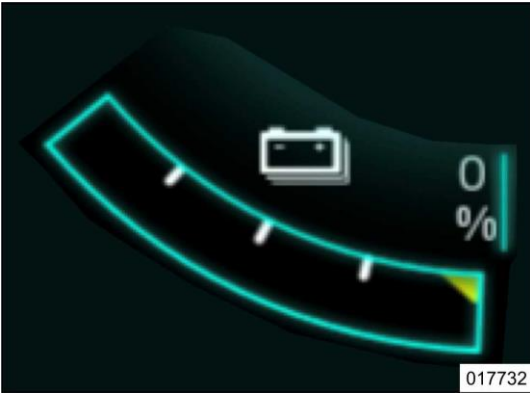
Step	Action
1	Connect the AC cable to the depot socket (63 Amp).
2	Turn the current-selector switch to "UNLIM" and wait until the indicator light turns green.
3	<p data-bbox="352 365 1369 432">Connect the charging cable to the socket of the vehicle. The socket is located behind the exterior lid on the right-hand side at the very rear.</p> <div data-bbox="408 450 940 833" style="text-align: center;">  <p data-bbox="863 801 932 824">016803</p> </div> <p data-bbox="963 801 1241 833">Figure 2: Vehicle socket</p> <ul data-bbox="352 871 1398 976" style="list-style-type: none"> • On the mobile charger: the indicator light turns blue and starts to flash. Wait (approximately 20 seconds) until the indicator light stops flashing and stays lit. • On the vehicle: the green indicator light next to the socket starts to flash. <p data-bbox="352 1016 1406 1084">The traction batteries are now charging. The progress of the charging process is displayed on the instrument panel of the vehicle.</p> <div data-bbox="408 1104 940 1496" style="text-align: center;">  <p data-bbox="863 1464 932 1487">017732</p> </div> <p data-bbox="963 1435 1369 1496">Figure 3: Traction batteries charge indicator</p>

Continued on next page.

TO DISCONNECT MOBILE CHARGER

Step	Action
1	<p>Press the stop button on the mobile charger.</p> <p>The blue indicator light on the mobile charger goes out.</p> <p><i>NOTE: If the traction batteries are fully charged, the indicator light will go out automatically. When the light is out, you do not have to press the stop button.</i></p>
2	<p>Press the release knob (see figure 4) and disconnect the charging cable from the socket of the vehicle. Put the cable back in its place. The indicator light on the mobile charger turns green.</p> <div data-bbox="486 591 1023 981" data-label="Image"></div> <p>Figure 4</p>
3	<p>Disconnect the AC cable from the depot socket.</p>

DISCLAIMER:

The procedures contained herein are not exclusive. Van Hool cannot possibly know, evaluate, or advise the transportation industry of all conceivable ways in which a procedure may be undertaken or of the possible consequences of each such procedure. Other procedures may be as good, or better, depending upon the particular circumstances involved. Each carrier who uses the procedures herein must first satisfy itself thoroughly that neither the safety of its employees or agents, nor the safety or usefulness of any products, will be jeopardized by any procedure selected.

VAN HOOL CUSTOMER PORTAL:

Consult the customer portal regularly for the latest service documentation. In addition to the maintenance manual, you will also find the operating manual and the spare parts catalogue of your vehicle on the customer portal. The customer portal is accessible through www.vanhool.be/service, and only with a code (password) from Van Hool. If you do not have a password yet, request it by using the above link.

INFORMATION HANDLING:

Important additions and modifications regarding technical information not yet included in the manual will be communicated through Service Bulletins.