



TEAM TIP

Release Date: August 16, 2022

SLI

Communication #: T-22-08-02

Model Year(s): 2020+

— Confidential and Proprietary —

VERSION: R01 (August 16, 2022)

IMPORTANT

If you are working with a printed copy, please verify you have the most current version of this document.

SUBJECT: CLUTCH ASSEMBLY AND CSC SERVICE PROCESS

PURPOSE

This Team Tip is designed to bring awareness to clutch service for 2020 and newer Slingshot models. Updated information has been added to the Service Manual to provide dealers with clear direction on how to properly install the clutch assembly as well as additional repair steps.

AFFECTED MODELS

MODEL YEAR	MODELS
2020 - Current	All Slingshot Models

T-22-08-02 PROCEDURE

SERVICE MANUAL OVERVIEW - CLUTCH PRESSURE AND DRIVEN PLATE INSTALLATION

During the installation process, it is critical that the pressure plate fasteners be drawn in evenly to reduce runout in the clutch assembly. If not installed properly, this runout can cause uneven clutch engagement or shutter during take-off as well as create premature wear and damage to the CSC and clutch assembly.

1. Install the clutch alignment tool **PU-51078** in order to support the pressure plate to flywheel assembly.

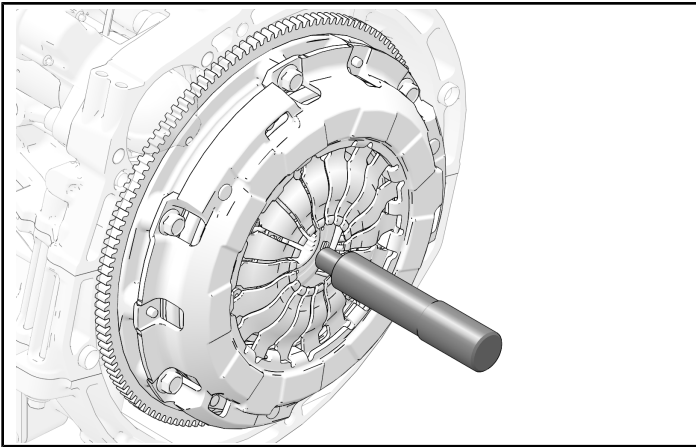

2. Hand start the pressure plate to flywheel bolts until they come into contact with the pressure plate, leaving the pressure plate.

3. Torque the pressure plate fasteners in the sequence shown. Use 180° intervals until the initial torque specification is reached to ensure the pressure plate is drawn down evenly.

NOTICE

Inspect for any gaps between the pressure plate and the flywheel. If any gaps are present, continue draw down process until seated against the flywheel.

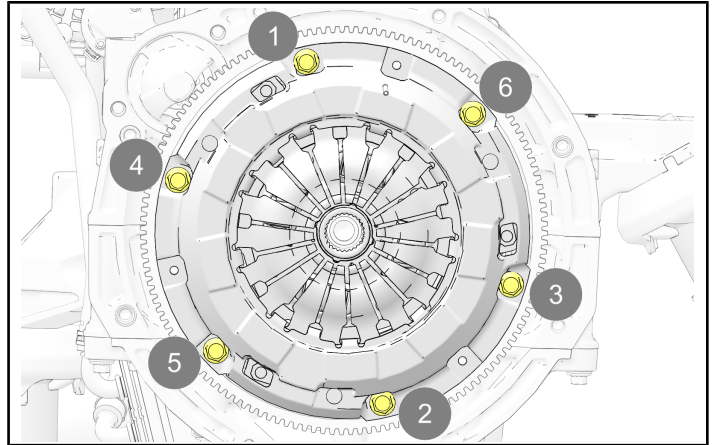

TORQUE

Pressure plate to flywheel fasteners:
Initial Torque:
7 ft-lbs (9 N·m)

4. Torque the pressure plate fasteners in the sequence shown. Use 180° intervals.

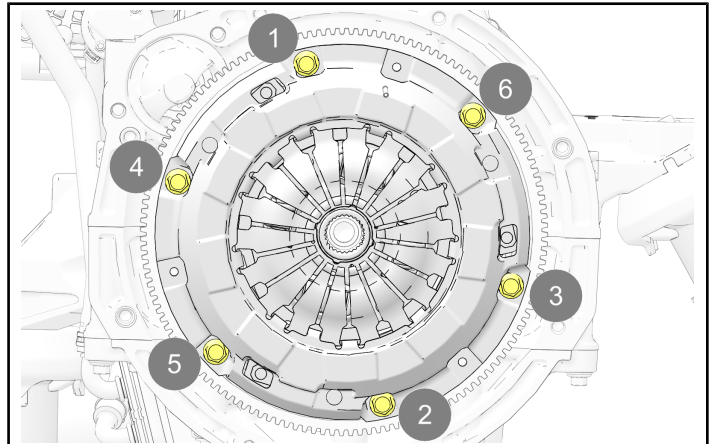

TORQUE

Pressure plate to flywheel fasteners:
Final Torque:
22 ft-lbs (30 N·m)

The information contained within this document is confidential and protected by U.S. and international copyright laws, and is the property of Polaris Inc. This document is provided for the sole use of authorized Polaris dealers and distributors. This document is not to be distributed, duplicated, or copied, digitally or otherwise, without the written consent of Polaris Inc.

CSC LUBRICATION (AUTODRIVE MODELS ONLY)

Lubrication of the CSC position sensor on AutoDrive models should be performed any time the engine and transmission are separated, or the CSC is replaced.

- It is recommended to apply a very thin layer of lithium or silicon grease to the speed sensor groove shown below and move the bearing in and out by hand to ensure good coverage. Any excess fluid should be wiped clean.

