

Spare Parts Requirements for High-Voltage Components: Additional Insulation Measurement Before Starting Vehicle: Observe Specified Procedure (74/21)

Model Series: **Taycan (Y1A / Y1B / Y1C)**

Model Year: **As of 2020**

Concerns: **High-voltage system**

Information: To prevent additional damage to the high-voltage system, which cannot be diagnosed during standard fault finding, a separate insulation measurement must be carried out **after a repair** on the high-voltage system **before starting up the vehicle**.

This measurement prevents consequential damage to the high-voltage components when the vehicle is restarted.

Action required: Perform separate insulation measurement after repairs and before starting the vehicle.

This measurement is performed using the PWIS Tester Application --> Measuring Equipment --> Measuring Program.



Information

Performing insulation measurement at the charging socket is **not** enough.

Preparatory work



Incorrect handling of high-voltage components

- Electric shock
 - Short circuit
 - Fire
 - Explosion
- ⇒ Only appropriately trained and authorized persons are permitted to work on high-voltage vehicles and components.
- ⇒ Required qualification: High voltage technician or high voltage expert.
- ⇒ Observe national requirements and legislation for this work.
- ⇒ Always use insulated tools, e.g. VAS 6883 Insulated Tool Set when working on these components.
- ⇒ Observe general warning notes for working on the high-voltage system. ⇒ *Workshop Manual '2X00IN General warning notes for working on the high-voltage system'*

- Work Procedure: 1 Read the warning notices. ⇒ *Workshop Manual '2X00IN General warning notes for working on the high-voltage vehicle electrical system'*
- 2 Isolate the high-voltage system from the power supply and complete the relevant documentation. ⇒ *Workshop Manual '2X00IN Isolating high-voltage system from power supply / starting high-voltage system'*
- 3 Remove rear luggage compartment trim panel. ⇒ *Workshop Manual '70061900 Removing and installing (centre) luggage compartment trim panel (luggage compartment cover)'*



Information

The test adapters at the charging sockets can differ from country to country.

- 4 Perform function test on test adapter. ⇒ *Workshop Manual '2X00IN Function test on high-voltage test adapter'*

Overview of high-voltage system

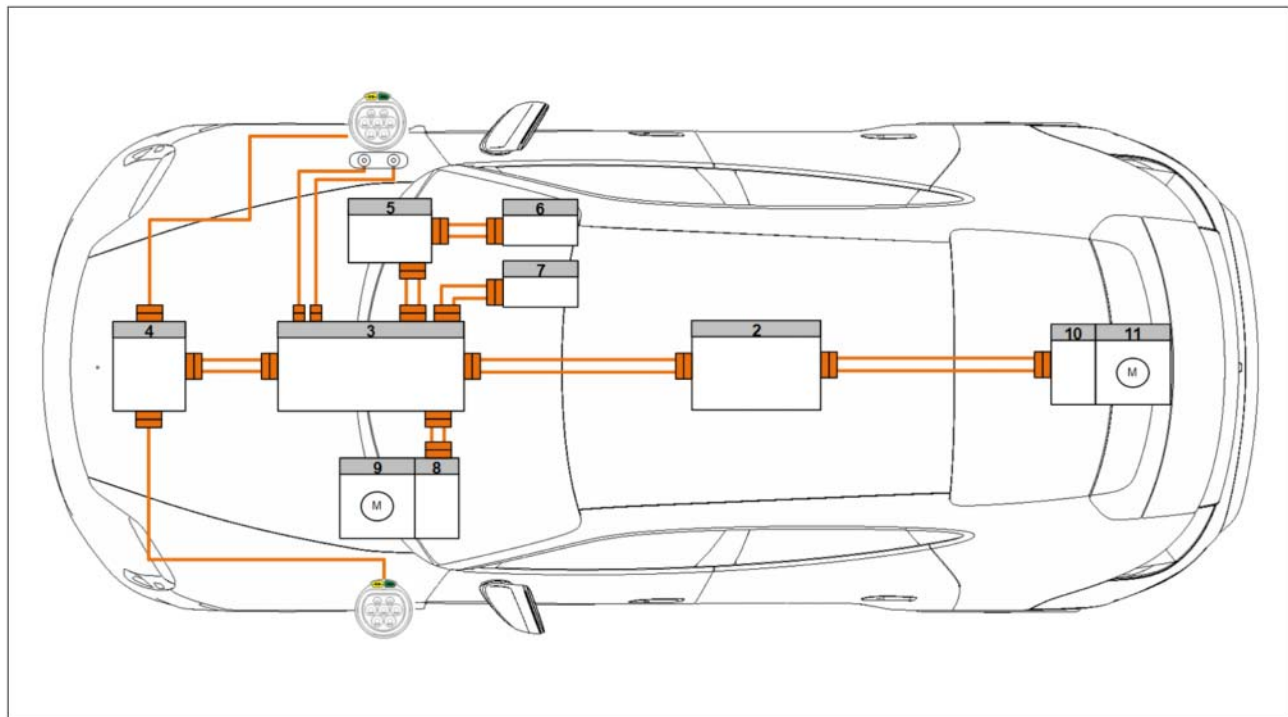

Overview of high-voltage system

- 2 – E-box
- 3 – High-voltage distributor
- 4 – High-voltage charger

- 5 – Voltage converter
- 6 – Air-conditioning compressor
- 7 – Interior heater
- 8 – Front power electronics
- 9 – Electric drive motor
- 10 – Rear power electronics
- 11 – Electric machine

Perform insulation measurement



WARNING

Incorrect handling of high-voltage components

- Electric shock
 - Short circuit
 - Fire
 - Explosion
- ⇒ Only appropriately trained and authorized persons are permitted to work on high-voltage vehicles and components.
- ⇒ Required qualification: High voltage technician or high voltage expert.
- ⇒ Observe national requirements and legislation for this work.
- ⇒ Always use insulated tools, e.g. VAS 6883 Insulated Tool Set when working on these components.
- ⇒ Observe general warning notes for working on the high-voltage system. ⇒ *Workshop Manual '2X00IN General warning notes for working on the high-voltage system'*



Information

Insulation measurements are performed and no resistance measurements are performed (check tester setting).

NOTE: The terms Isolation and Insulation are often used interchangeably in Porsche documentation. For example, to find the source of an **isolation fault** using VAS 6558A, select the **HV Isolation Measurement** program to measure **HV insulation resistance**.

Work
Procedure:

- The measurements must be performed using **9900 - PIWIS Tester 3** and a **high-voltage testing module**.
- To obtain the required measuring resistance, the measuring voltage must be present on the insulation tester until a **stable measured value** is displayed.
- Two measurements must always be performed for each measuring point. Positive terminal on shielding and negative terminal on shielding.

- A measurement is only regarded as being within the setpoint value range if both measured values (positive terminal on shielding and negative terminal on shielding) are within the specified range.

Each insulation measurement must be performed four times because diodes are installed in the high-voltage system.

High-voltage positive to shielding and high-voltage negative to shielding.



Measurement 1 and 2 (sample result)

Shielding to high-voltage positive and shielding to high-voltage negative.



Measurement 3 and 4 (sample result)



Information

The special tool number of the test adapter can differ from country to country. (**VAS 6558/10-2**, **VAS 6558/18A**, **VAS 6558/13A** or **VAS 6558/22**)

- 1 Determine the result for **measurement 1 (DC high-voltage line from high-voltage distributor to DC charging socket)**.
 - 1.1 Connect charging socket test adapter **VAS 6558/10-2 (DC)** to the DC charging socket.
 - 1.2 Set test voltage of the tester to **1,000 V**.
 - 1.3 Perform measurement 1 and record the result.

Nominal value > 1.1 MΩ

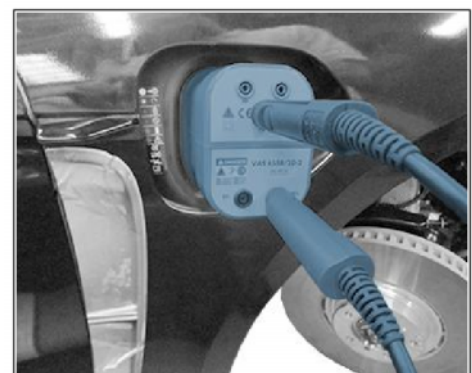

Right charging socket



Information

The special tool number of the test adapter can differ from country to country. (**VAS 6558/10-1**, **VAS 6558/14A** or **VAS 6558/17A**)

- 2 Determine the result for **measurement 2 (AC high-voltage line from high-voltage distributor to AC charging socket)**.

- 2.1 Connect charging socket test adapter **VAS 6558/10-1 (AC)** to the left charging socket.
- 2.2 Set test voltage of the tester to **500 V**.
- 2.3 Perform measurement 2 and record the result.

Setpoint values: > 1,1 MΩ

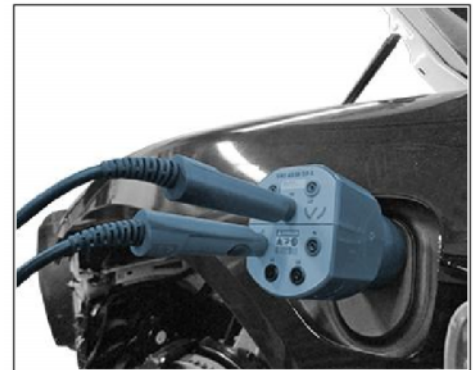

Left charging socket

- 3 Determine the result for **measurement 3 of the high-voltage line (from high-voltage distributor to passenger compartment heater) to the high-voltage distributor**.

- 3.1 Connect **VAS 6558/9-6A - high-voltage test adapter** between high-voltage distributor and high-voltage line (from high-voltage distributor to passenger compartment heater).
- 3.2 Set test voltage of the tester to **1,000 V**.
- 3.3 Perform measurement 3 and record the result.

Setpoint values: > 1,1 MΩ

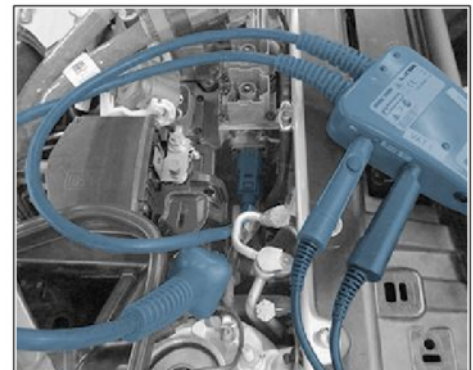

High-voltage distributor

- 4 Lift up body cover \Rightarrow *Body cover -1-* to allow access to the high-voltage line for the electric machine at the rear using a plastic wedge and remove it.

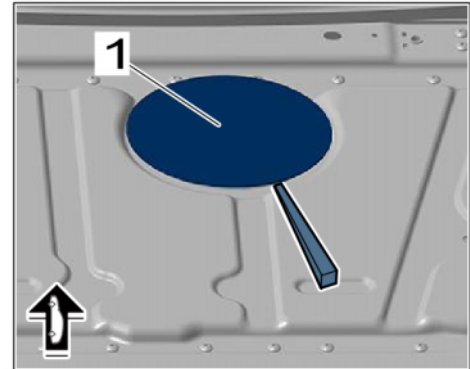

Body cover



Information

Wear gloves with cut protection when loosening and detaching the traction line.

- 5 Unscrew fastening screws \Rightarrow *Rear power electronics traction line -1-* for the connection for the rear power electronics traction line and disconnect them.

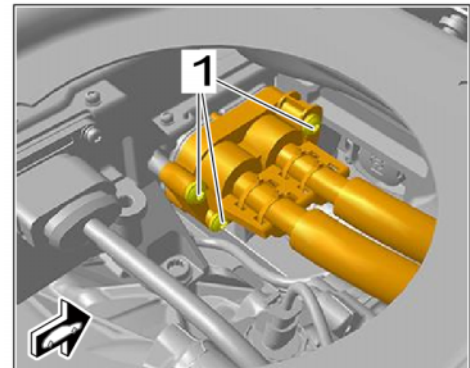

Rear power electronics traction line

- 6 Determine the result for **measurement 4 of the traction line (from E-box to rear power electronics)**.
- 6.1 Connect **HV test adapter** to the traction line (from E-box to rear power electronics).
- 6.2 Set test voltage of the tester to **1,000 V**.
- 6.3 Perform measurement 4 and record the result.

Setpoint values: > 1,1 M Ω



Rear power electronics traction line



Information

A separate traction line is required as a special tool for the following measurement. If this is not yet available in the workshop, it must be ordered.

Part number: 9J1971015B - Traction line

- 7 Guide one end of the separate traction line through the opening from the luggage compartment floor and connect it to the rear power electronics.

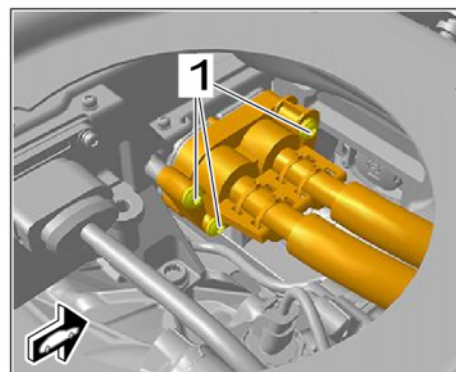

Rear power electronics traction line

- 8 Determine result for **measurement 5 of the traction line (rear power electronics - E-box)**.
 - 8.1 Connect **high-voltage measuring adapter** to the other end of the separate traction line.
 - 8.2 Set test voltage of the tester to **1,000 V**.
 - 8.3 Perform measurement 5 and record the result.

Setpoint values: > 5 MΩ



Traction line

Result of check		Action
(✓)	All measurements are within the required range.	End of test. The high-voltage system is OK and can be commissioned.
(✗)	One or more measurements are not within the required range.	If an insulation fault in the high-voltage system is found during insulation measurement, the identification of the damaged component must be carried out fully for the affected areas (front or rear end). For instructions, see: ⇒ <i>Workshop Manual '2X00IN Insulation fault finding'</i>

Concluding work

Work Procedure: 1 Remove all adapters and plug in and lock all electrical plug connections.

2 Position body cover ⇒ *Removing body cover -1-* to allow access to the high-voltage line for the electric machine at the rear and clip it in.

3 Install rear luggage compartment trim panel. ⇒ *Workshop Manual '70061900 Removing and installing (centre) luggage compartment trim panel (luggage compartment cover)'*

4 Start the high-voltage system. ⇒ *Workshop Manual '2X00IN Isolating high-voltage system from power supply / starting high-voltage system'*

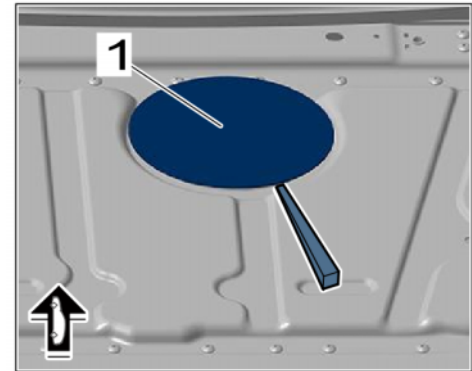

Removing body cover

Invoicing



Information

The tests must be fully documented and verifiable.

For technical reasons, it is not possible to define a fixed working time under 2X00 for this work. For this reason, a "once-off labor operation" must be created for invoicing this work using the following data:

- Labor operation number: 270803
- Description: Additional insulation measurement following vehicle repairs (TI 74/21)
- Time units: **max.** 200 TU

Invoicing: For documentation and warranty invoicing, enter the relevant **Customer service ID (FES5) of the component** responsible for causing the problem, in combination with the damage category (SA4).

References: ⇒ *Workshop Manual '2X00IN General warning notes for working on the high-voltage vehicle electrical system'*

⇒ *Workshop Manual '2X00IN Isolating high-voltage system from power supply / starting high-voltage system'*

⇒ *Workshop Manual '2X00IN Function test on high-voltage test adapter'*

⇒ *Workshop Manual '2X00IN Insulation fault finding'*

⇒ *Workshop Manual '70061900 Removing and installing (centre) luggage compartment trim panel (luggage compartment cover)'*

Important Notice: Technical Bulletins issued by Porsche Cars North America, Inc. are intended only for use by professional automotive technicians who have attended Porsche service training courses. They are written to inform those technicians of conditions that may occur on some Porsche vehicles, or to provide information that could assist in the proper servicing of a vehicle. Porsche special tools may be necessary in order to perform certain operations identified in these bulletins. Use of tools and procedures other than those Porsche recommends in these bulletins may be detrimental to the safe operation of your vehicle, and may endanger the people working on it. Properly trained Porsche technicians have the equipment, tools, safety instructions, and know-how to do the job properly and safely. Part numbers listed in these bulletins are for reference only. The work procedures updated electronically in the Porsche PIWIS diagnostic and testing device take precedence and, in the event of a discrepancy, the work procedures in the PIWIS Tester are the ones that must be followed.

© 2022 Porsche Cars North America, Inc.