

Door Symptom - Noise Complaints from the Door Panel Area: Observe Documentation Specifications (SY 68/22)

Revision: This bulletin replaces bulletin Group 7 SY 68/22, dated May 26, 2022.

Model Year: **As of 2020**

Model Series: **911 (992)**

Information: The case documentation in the warranty claim often does not clearly indicate the cause and details of the corrective measures carried out in the event of noises in the door and door panel.

In order to allow fault correction measures at the factory, fault sources such as loose components or noises must be set:

- Line/train
- Electric plug connections
- Handle
- Cover
- Moulding
- Actuating lever
- Switch
- Material contact point
- Screw connections
- Clips, etc.

must be clearly documented.

The resultant remedial action, e.g.:

- felt/foam installed
- greased
- clip replaced
- screw tightened
- part replaced, etc.

must also be clearly documented.

For this purpose, the source of the fault in the relevant illustration, inner door panel ⇒ *View of inner door panel*, outer door panel ⇒ *View of outer door panel* or door without door panel ⇒ *View of door without door panel* must be marked in future and must be supplied with a detailed description of the fault source and corrective measure in accordance with the warranty claim.



Information

The warranty claim can only be reimbursed if all documents submitted are complete and comprehensible.

Sample documentation:

- Electric line in the door panel loose. Electric line secured with a tie-wrap. For exact fault location, see Appendix xy ⇒ *Appendix xy: Loose cable for door panel*

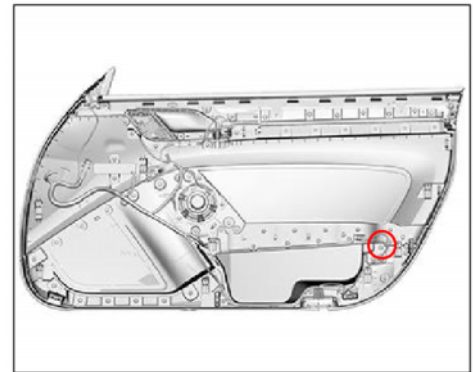

Appendix xy: Loose cable for door panel

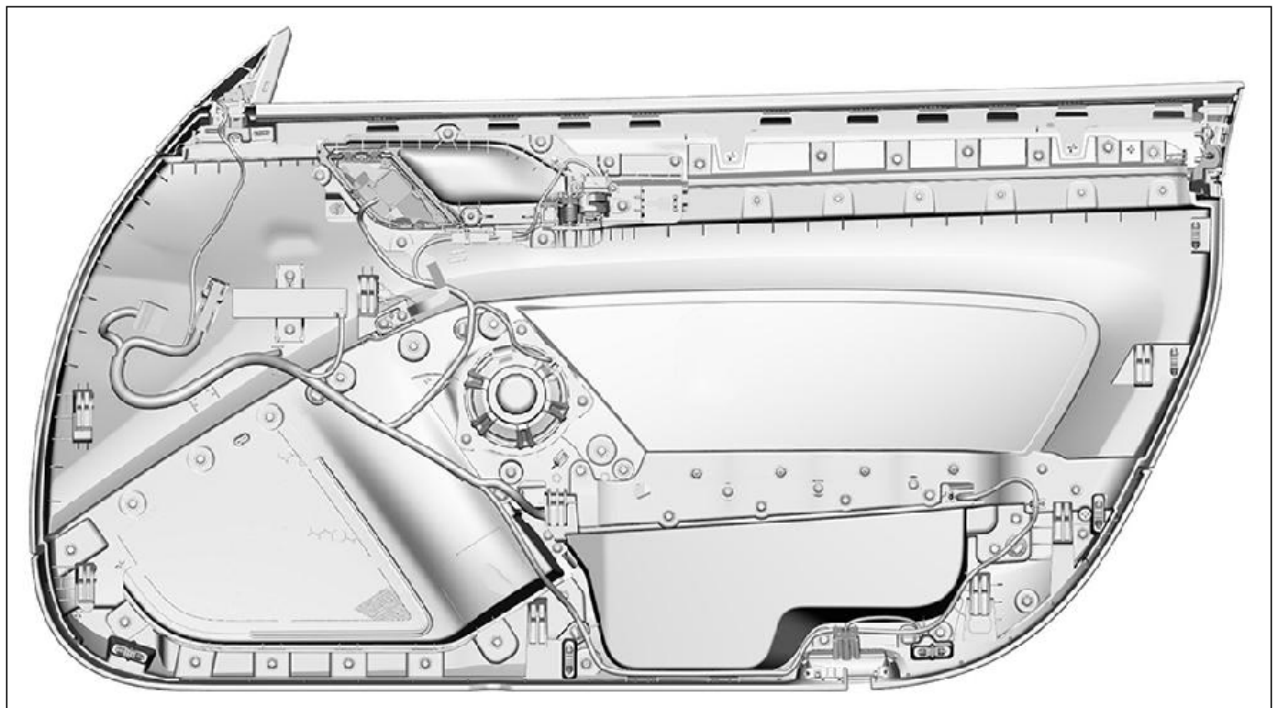

View of inner door panel

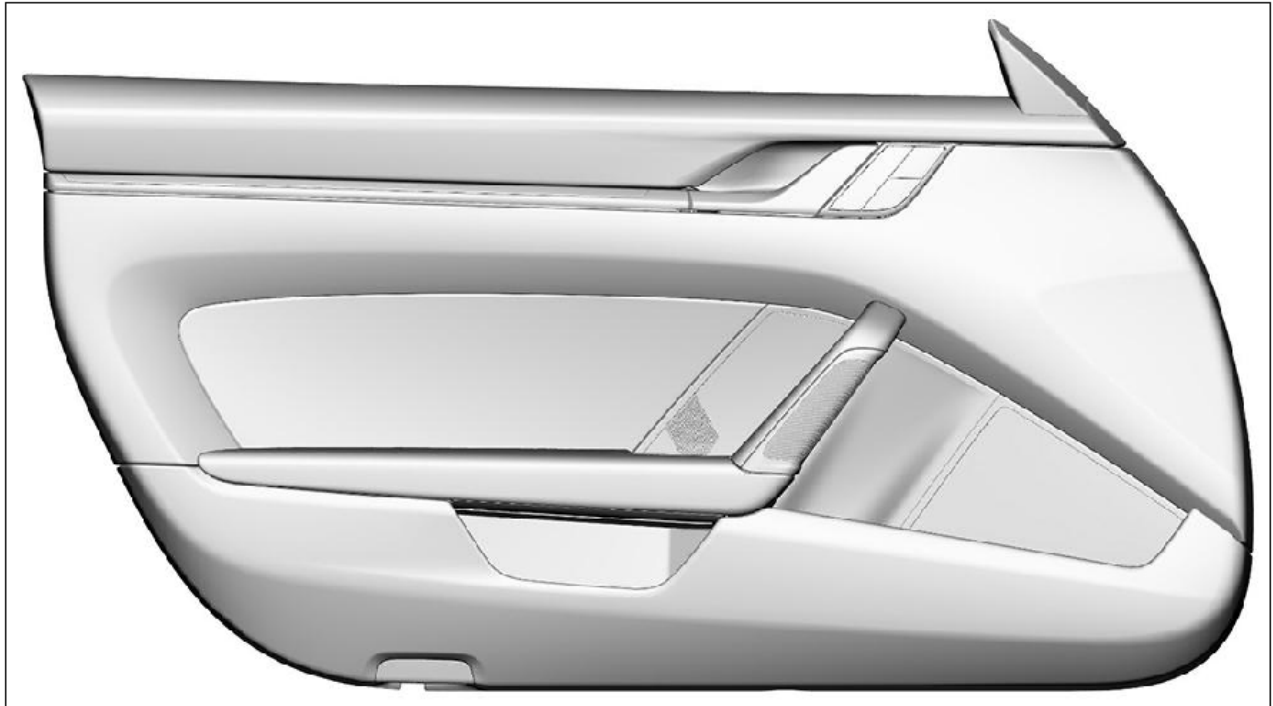

View of outer door panel



View of door without door panel

Revision: This bulletin replaces bulletin Group 7 SY 68/22, dated May 26, 2022.

Model Series: **Taycan (Y1A / Y1B / Y1C)**

Information: The case documentation in the warranty claim often does not clearly indicate the cause and details of the corrective measures carried out in the event of noises in the door and door panel.

In order to allow fault correction measures at the factory, fault sources such as loose components or noises must be set:

- Line/train
- Electric plug connections
- Handle
- Cover
- Moulding
- Actuating lever
- Switch
- Material contact point
- Screw connections
- Clips, etc.

must be clearly documented.

The resultant remedial action, e.g.:

- felt/foam installed
- greased
- clip replaced
- screw tightened
- part replaced, etc.

must also be clearly documented.

For this purpose, the source of the fault in the relevant illustration, inner door panel ⇒ *View of front inner door panel / ⇒ View of rear inner rear door panel*, outer door panel ⇒ *View of front outer door panel / ⇒ View of rear outer rear door panel* or door without door panel ⇒ *View of front door without door panel / ⇒ View of rear door without door panel* must be marked in the future and must be supplied with a detailed description of the fault source and corrective measure in accordance with the warranty claim.



Information

The warranty claim can only be reimbursed if all documents submitted are complete and comprehensible.

Sample documentation:

- Electric line in the door panel loose. Electric line secured with a tie-wrap. For exact fault location, see Appendix xy ⇒ *Appendix xy: Loose cable for door panel*

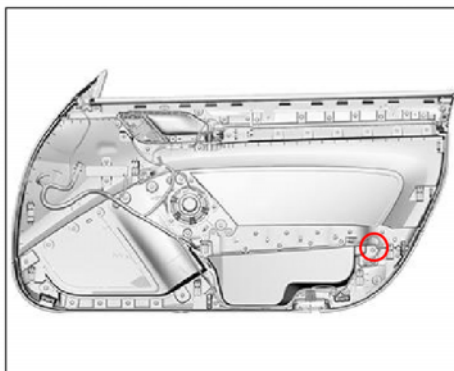

Appendix xy: Loose cable for door panel

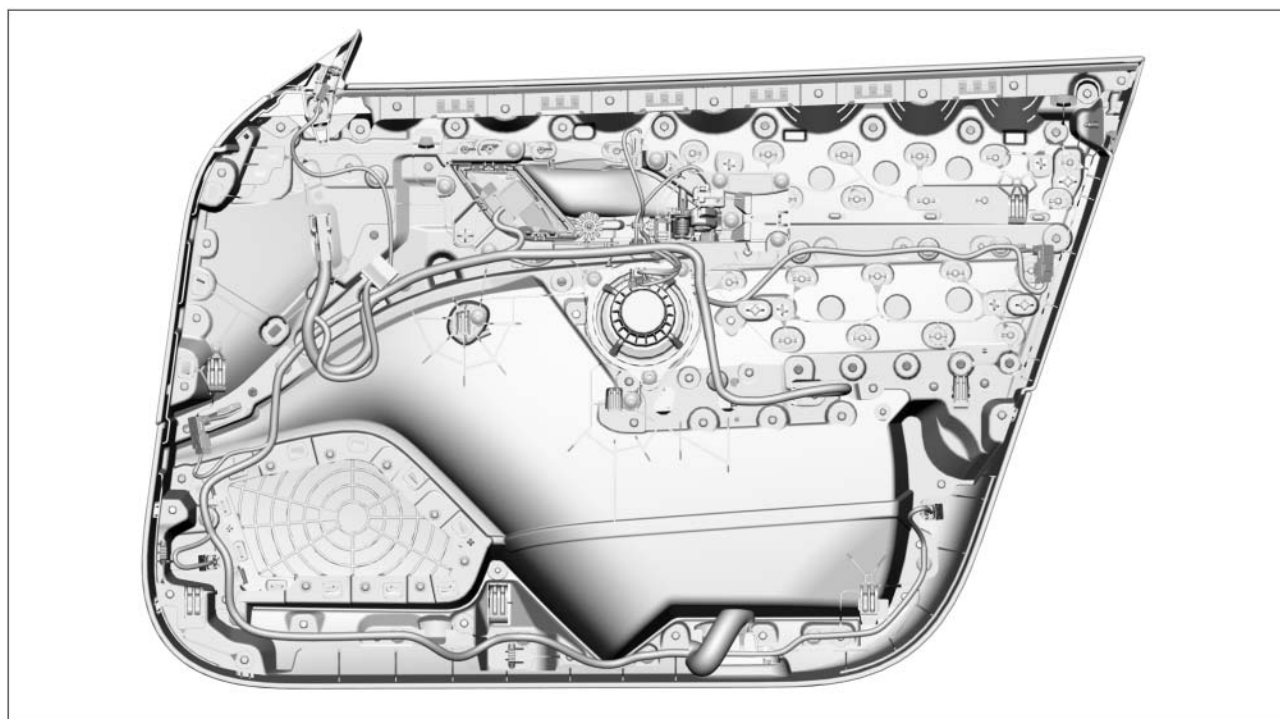

View of front inner door panel

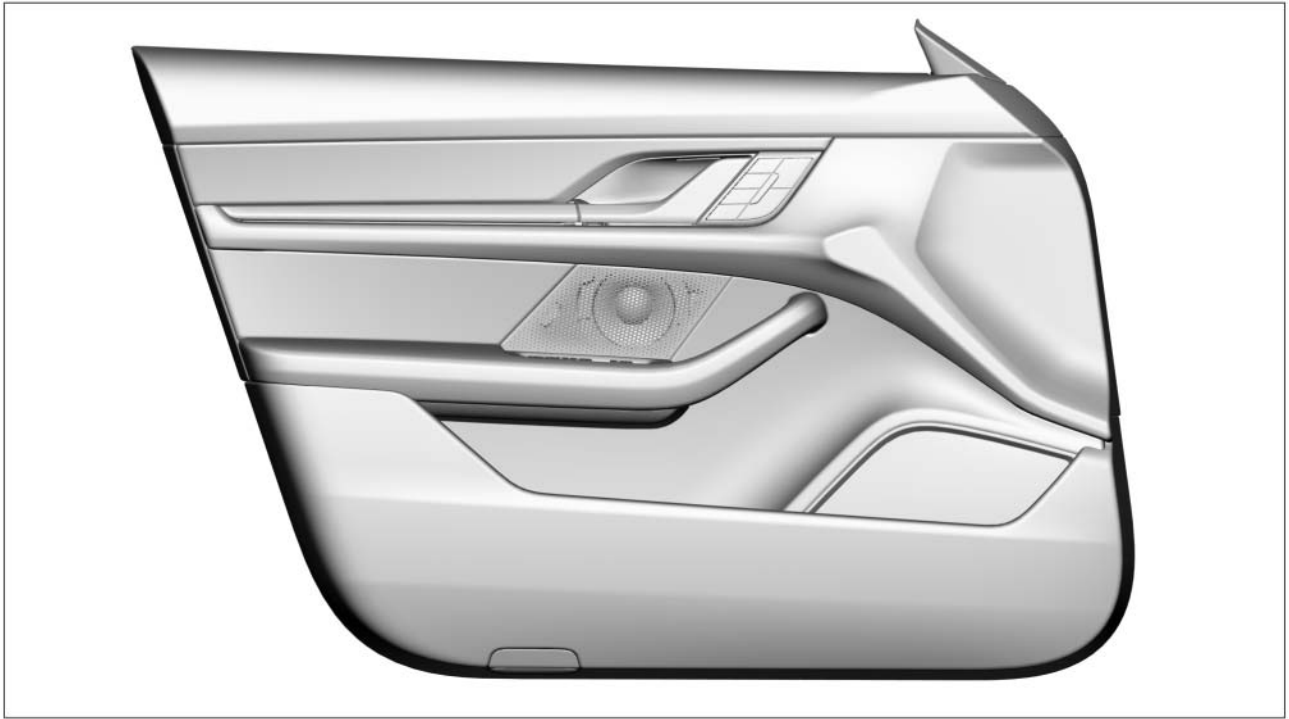

View of front outer door panel



View of front door without door panel

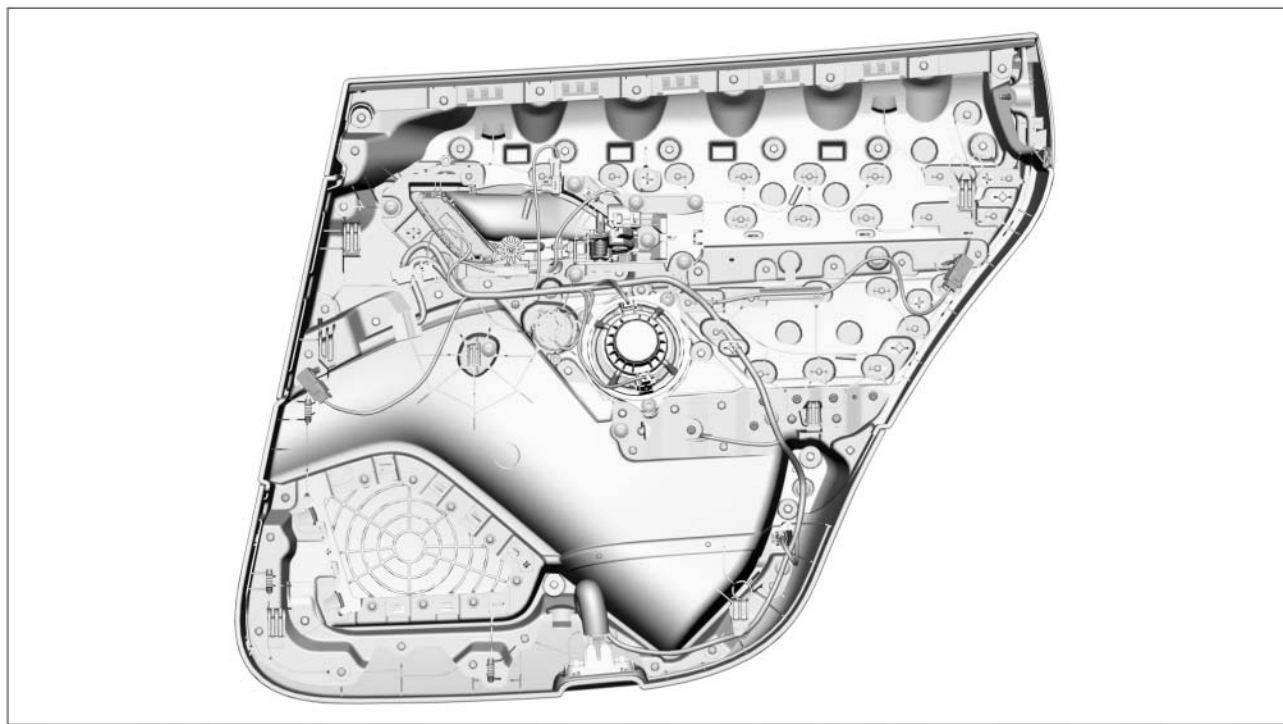

View of rear inner rear door panel



View of rear outer rear door panel

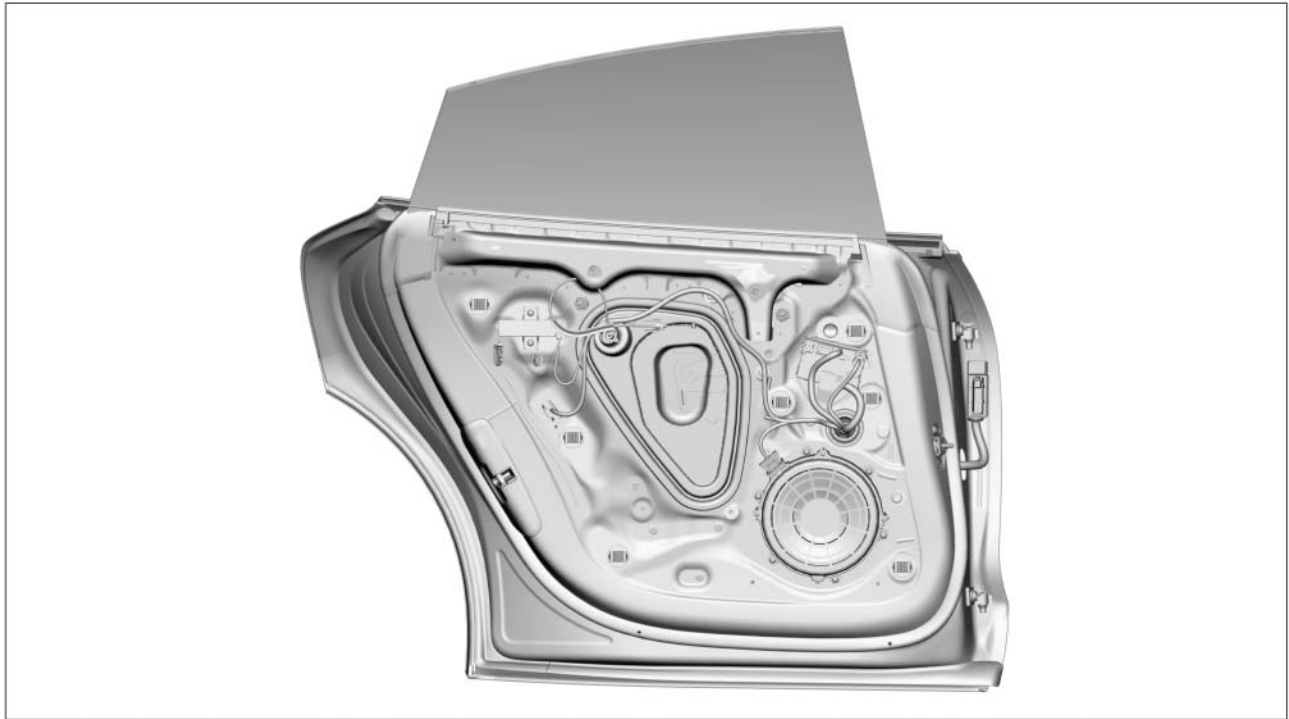

View of rear door without door panel

Important Notice: Technical Bulletins issued by Porsche Cars North America, Inc. are intended only for use by professional automotive technicians who have attended Porsche service training courses. They are written to inform those technicians of conditions that may occur on some Porsche vehicles, or to provide information that could assist in the proper servicing of a vehicle. Porsche special tools may be necessary in order to perform certain operations identified in these bulletins. Use of tools and procedures other than those Porsche recommends in these bulletins may be detrimental to the safe operation of your vehicle, and may endanger the people working on it. Properly trained Porsche technicians have the equipment, tools, safety instructions, and know-how to do the job properly and safely. Part numbers listed in these bulletins are for reference only. The work procedures updated electronically in the Porsche PIWIS diagnostic and testing device take precedence and, in the event of a discrepancy, the work procedures in the PIWIS Tester are the ones that must be followed.

© 2022 Porsche Cars North America, Inc.