

Sports Exhaust System - Silver (OP8) / Black (OP9)

Vehicle Type: **Macan / Macan T**

Model Year: **As of 2022**

Engine Type: **DMT** (basic engine) = R4 / 2.0 liter / 195 kW (265 hp)

- **DMTB** with performance class **D3Q** = 195 kW (265 hp)

Restrictions: **ONLY** approved for vehicles produced from 49/2021 (week/year)!

ONLY Macan T: Sports exhaust system – tailpipe in silver chrome-plated look– (OP8) is not approved!

Information: **Retrofitting**



Information



Figure 1

Notes: In the sports exhaust system, the signal for activating the flaps in the rear silencers comes from the respective current map in the DME control unit (DME SG). This depends on the driving status and the accelerator pedal position among other things.

The sports exhaust system can be activated and deactivated separately using the new "Twin tailpipe" button (center console control panel ⇒ *Figure 1*) or the standard "Sport" button. The sports exhaust system is active in "Sport" and "Sport Plus" modes on vehicles with Sport Chrono Package.

The engine power and exhaust behavior of the vehicle are not affected.

Under the individual equipment "OP8 - Sport exhaust system incl. sport tailpipes silver" or "OP9 - Sport exhaust system incl. sport tailpipes black", the sport exhaust system is also available ex works for new Macan Basic vehicles. Only the "OP9 – Sports exhaust system including sports tailpipes in black" can be ordered straight from the factory for the Macan T.

Parts Info:	95B.044.220¹	⇒ Sports exhaust system – Tailpipe in Silver chrome-plated look, set
	95B.044.220.A	⇒ Sports exhaust system – Tailpipe in Black chrome-plated look, set

¹ **NOT** approved for Macan T!

Parts List:

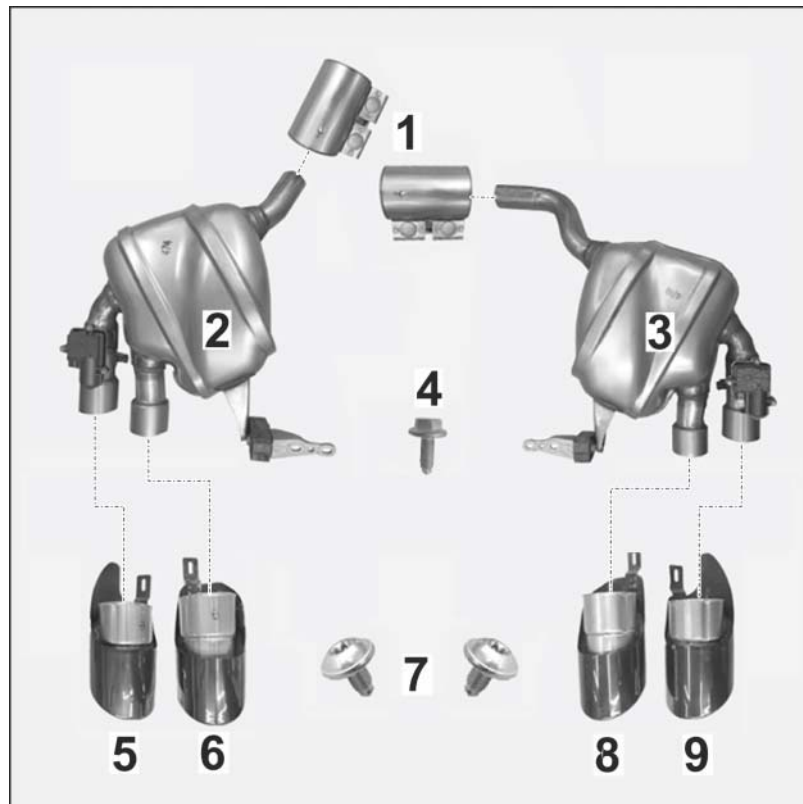

Figure 2

Parts included for exhaust system (⇒ *Figure 2*):

958.111.220.10	2 x	Clamping sleeve, Ø 65 x 88 ⇒ <i>Figure 2-1-</i>
95B.253.601.CY	1 x	Rear silencer assembly – left ⇒ <i>Figure 2-2-</i>
95B.253.600.BY	1 x	Rear silencer assembly – right ⇒ <i>Figure 2-3-</i>
N.106.620.01	4 x	Hexagon-head bolt, M8 x 40 ⇒ <i>Figure 2-4-</i>
95B.253.681.R ²	1 x	Sports tailpipe, black chrome-plated, outer left ⇒ <i>Figure 2-5-</i>
95B.253.681.Q ²	1 x	Sports tailpipe, black chrome-plated, inner left ⇒ <i>Figure 2-6-</i>
999.073.594.01	4 x	Countersunk screw, M6 x 12 PA ⇒ <i>Figure 2-7-</i>
95B.253.682.Q ²	1 x	Sports tailpipe, black chrome-plated, inner right ⇒ <i>Figure 2-8-</i>
95B.253.682.R ²	1 x	Sports tailpipe, black chrome-plated, outer right ⇒ <i>Figure 2-9-</i>
95B.253.681.P ²	1 x	Sports tailpipe, silver chrome-plated, outer left (not shown)
95B.253.681.N ²	1 x	Sports tailpipe, silver chrome-plated, inner left (not shown)
95B.253.682.N ²	1 x	Sports tailpipe, silver chrome-plated, inner right (not shown)
95B.253.682.P ²	1 x	Sports tailpipe, silver chrome-plated, outer right (not shown)

² **ONLY** contained in respective set!



Figure 3

Parts included for electrical system (⇒ *Figure 3*):

95B.907.159.M	1 x	Engine noise control unit ⇒ <i>Figure 3-1-</i>
999.076.081.40	2 x	Hexagon collar nut, T5/16 x 11.2 (plastic) ⇒ <i>Figure 3-2-</i>
4H0.907.601.E	1 x	Engine noise pulse sender ⇒ <i>Figure 3-3-</i>
N.908.877.03	1 x	M6 hexagon collar nut, self-locking ⇒ <i>Figure 3-4-</i>
95B.044.200.25	1 x	Wire harness for engine noise control unit/pulse sender including adapter cable (secured) ⇒ <i>Figure 3-5-</i>
95B.044.213.B	1 x	Wire harness for connection point/exhaust flap – left-hand drive vehicle ⇒ <i>Figure 3-6-</i>
N.912.098.01	1 x	Flat screw with internal serration, 7/16 ⇒ <i>Figure 3-7-</i>
999.513.052.40	25 x	Tie-wrap, 4.8 x 188 (not shown)



Information

ONLY in the event of repairs/replacement:

Items **WITHOUT** a part number in the parts list can be found/ordered from the Porsche Electronic Parts Catalog = PET.

Check model year and vehicle equipment (I-no.) in the standard catalog!

Materials:	000.043.172.00	1 x	Sealing cord
	— — —	1 x	Commercially available rust solvent, e.g. WD40
	— — —	1 x	Wrapping tape (commercially available)
	— — —	1 x	Auxiliary line (Tekalan or Teflon hose) approx. 1,500 mm/ 4.92 ft long

Tools: **VAS 6931 Transmission and gearbox jack**

VAG 1783 - Torque wrench or equivalent

VAS 6935 Pole terminal puller

9873 - Bonnet stay

3438 - Hooks

9900 - PIWIS Tester 3

Three-mandrel pliers for hoses and sleeves (commercially available)

Restraining strap for securing loads

Assembly: 1 Preliminary work

1.1 Drive the vehicle onto a lifting platform. ⇒ *Workshop Manual '4X00IN Lift vehicle'*

1.2 Connect a battery charger. ⇒ *Workshop Manual '2X00IN Battery trickle charge'*

CAUTION

Hot components

- Risk of burns
- ⇒ Let hot components cool down.
- ⇒ Wear personal protective gear.

1.3 Work in the exhaust system area

1.3.1 Remove standard tailpipes
(⇒ Figure 5). ⇒ *Workshop Manual '263519 Removing and installing tailpipe trim'*



Figure 5

1.3.2 Unlock and disconnect the electrical plug connection for the exhaust flap actuator on the left-hand rear silencer (⇒ Figure 6). ⇒ *Workshop Manual '265119 Removing and installing exhaust flap actuator'*

- 1 – Electric plug connection
- 2 – Rear muffler, left

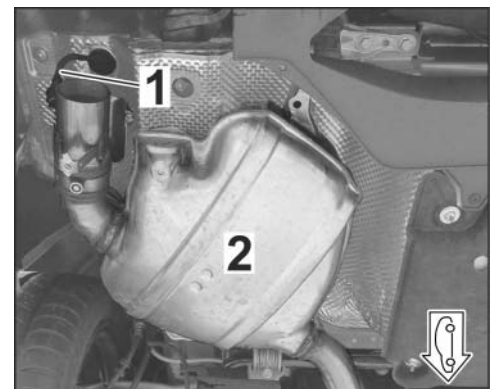

Figure 6

- 1.3.3 Secure the exhaust pipe with a suitable securing device (e.g. strap, load securing device or hook) to prevent it from folding down (⇒ *Figure 7*).

- 1 – Exhaust pipe
2 – Hooks

- 1.3.4 Support the rear silencer with **gearbox and unit jacks** and secure with a tensioning strap.

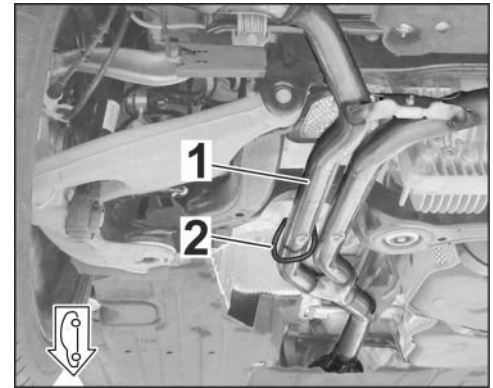

Figure 7



Information

The help of another person is required for this step.

- 1.3.5 Separate the rear silencer at the middle marking points on the exhaust pipe (⇒ *Figure 8*).
⇒ *Workshop Manual '263355 Replacing rear silencer'*



Figure 8



CAUTION

Heavy components

- Risk of pinching
- ⇒ Wear personal protective gear.
- ⇒ Get someone to help if necessary.

1.3.6 Unscrew M8 x 40 hexagon nuts on the rear silencer holder (⇒ *Figure 9*).

- 1 – Hexagon-head bolts, M8 x 40
- 2 – Rear muffler, left

Remove rear silencer.

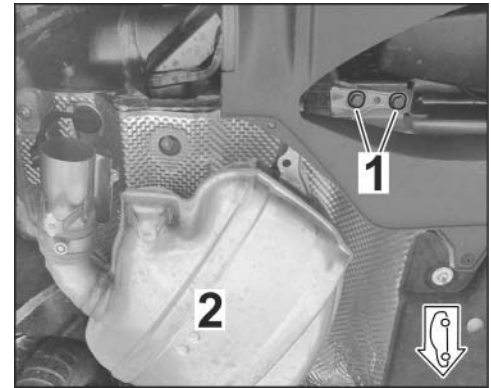

Figure 9

1.3.7 Detach heat shield in the rear silencer area – at the right (⇒ *Figure 10*) and bend it down slightly.

- 1 – Cap nut
- 2 – Heat shield
- 3 – Dummy plug
- 4 – Filler

1.3.8 Remove dummy plug on underbody and de-burr using a spatula (⇒ *Figure 10-Magnifier*).

1.4 Expose the plenum panel area

1.4.1 Move front lid to service position. ⇒ *Workshop Manual '552213 Securing front lid (service position)'*

1.4.2 Remove wiper arms. ⇒ *Workshop Manual '922519 Removing and installing wiper arm'*

1.4.3 Remove cowl panel cover. ⇒ *Workshop Manual '508719 Removing and installing cowl panel cover'*

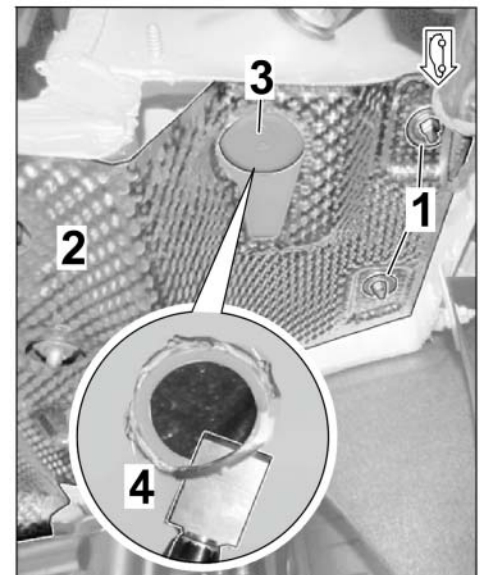

Figure 10

- 1.4.4 Remove cover on fuse box (E-box) in cowl panel (⇒ *Figure 11*).
⇒ *Workshop Manual '978409 Loosening and securing fuse box'*

- 1 – Fuse box (E-box) in cowl panel
- 2 – Foam pads on bulkhead

- 1.4.5 Remove foam pads on bulkhead (⇒ *Figure 11-2-*).

- 1.5 Expose A-pillar area (on driver's side)

- 1.5.1 Remove dashboard trim panel (⇒ *Figure 12-1-*). ⇒ *Workshop Manual '701619 Remove and install dashboard trim panel'*

- 1 – Dashboard trim panel
- 2 – Air vent (instrument cluster)
- 3 – Trim panel under dashboard

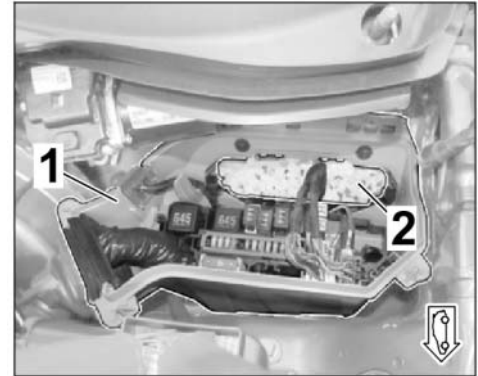

Figure 11

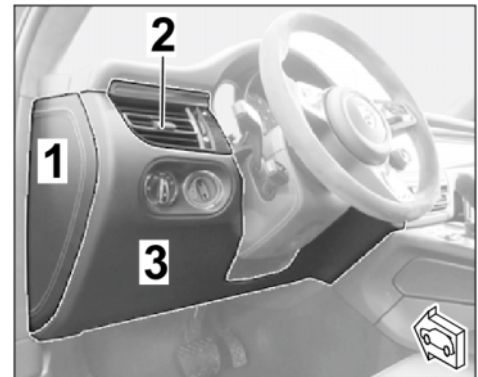

Figure 12

- 1.5.2 Remove air vent (on instrument cluster ⇒ *Figure 12-2-1* ⇒ *Figure 13-1-*) and air vent unit (underneath the PCM ⇒ *Figure 13-3-*).

- 1 – Air vent (instrument cluster)
- 2 – Dashboard moulding (right)
- 3 – Air vent unit (PCM)
- 4 – Trim panel under dashboard

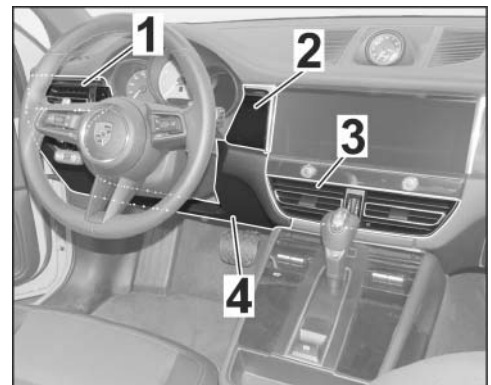

Figure 13

- 1.5.3 Remove dashboard moulding/trim panel (at the right ⇒ *Figure 13-2-*). ⇒ *Workshop Manual '70581902 Removing and installing dashboard moulding on driver's side (right)'*

1.5.4 Remove trim panel under dashboard (⇒ Figure 14). ⇒ Workshop Manual '701919 Removing and installing trim panel under dashboard on driver's side'

- 1 – Trim panel under dashboard
- 2 – Dashboard

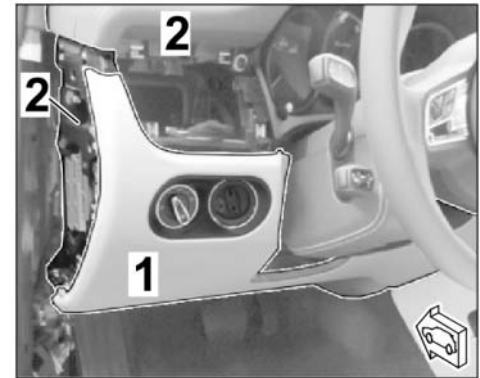

Figure 14

1.5.5 Remove front inner door sill trim (⇒ Figure 15). ⇒ Workshop Manual '680519 Removing and installing front inner door sill trim'

- 1 – Front lid release
- 2 – Front inner door sill trim (on driver's side)



Figure 15

1.6 Expose B-pillar area (on driver's side)

1.6.1 Remove luggage compartment cover and empty the luggage compartment.

1.6.2 Detach/remove rear backrest (⇒ Figure 16 -1-) ⇒ Workshop Manual '724719 Removing and installing rear backrest'

- 1 – Rear backrest
- 2 – Rear seat
- 3 – Upper part of B-pillar trim panel (on driver's side)
- 4 – Lower part of B-pillar trim panel (on driver's side)

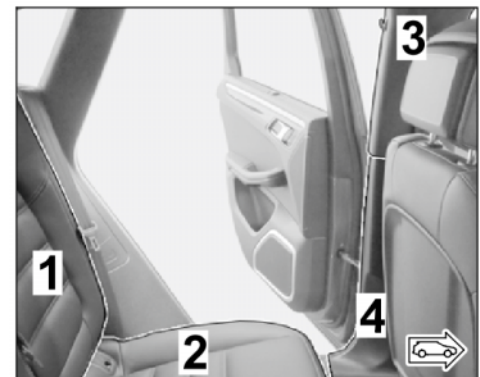

Figure 16

1.6.3 Remove rear seat (⇒ Figure 16 -2-). ⇒ Workshop Manual '724819 Removing and installing rear seat'

1.6.4 Remove upper part of B-pillar trim panel (on driver's side ⇒ Figure 16-3-). ⇒ Workshop Manual '706719 Removing and installing upper part of B-pillar trim panel'

- 1.6.5 Remove lower part of B-pillar trim panel (on driver's side ⇒ *Figure 16-4*). ⇒ *Workshop Manual '70671903 Removing and installing lower part of B-pillar trim panel'*
- 1.7 Uncover C-pillar / luggage compartment area
- 1.7.1 Remove side trim panel for rear luggage compartment (left/right). ⇒ *Workshop Manual '700319 Removing and installing side trim panel for rear luggage compartment'*
- 1.7.2 Remove side luggage compartment trim panel (luggage compartment cover). ⇒ *Workshop Manual '700619 Removing and installing side luggage compartment trim (luggage compartment cover)'*
- 1.7.3 **ONLY** for vehicles with spare wheel (space-saving – 1G1 / 1G4):
Remove compressor tool kit (⇒ *Figure 17*).
- 1 – Compressor tool kit
2 – Clamping washer 5 x 30
- 1.7.4 Remove rear inner door sill trim (driver's side). ⇒ *Workshop Manual '680519 Removing and installing rear inner door sill trim'*

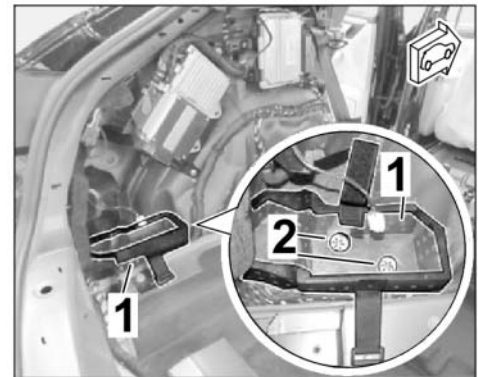

Figure 17

- 2 Install engine noise control unit and pulse sender
- 2.1 Release secured adapter cable with plug connection (3-pin) and bag of small parts from electric wire harness for engine noise control unit/pulse sender (⇒ *Figure 18*).
- 1 – Wire harness for engine noise control unit/pulse sender including adapter cable
2 – Adapter cable with plug connection (3-pin)
3 – Bag of small parts
- 2.2 Install engine noise control unit (⇒ *Figure 19*)
- 2.2.1 Connect plug connection for wire harness for engine noise control unit/pulse sender to the engine noise control unit (6-pin).

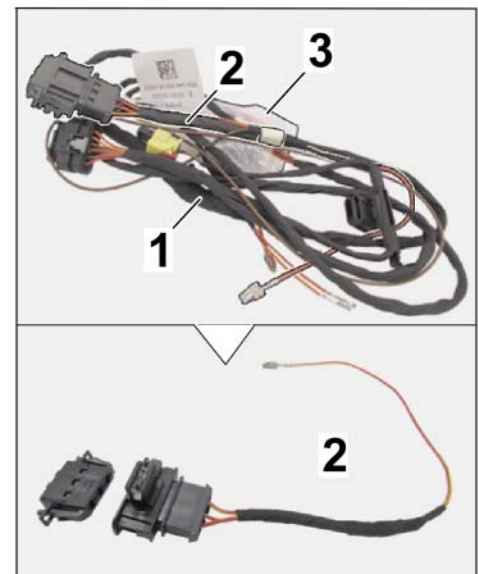

Figure 18

2.2.2 Position the engine noise control unit on stud bolt M6 (2 x) in the water tank and fasten with hexagon collar nut (2 x) (\Rightarrow Figure 19).

- 1 – Engine noise control unit
- 2 – Wire harness for engine noise control unit/pulse sender
- 3 – Hexagon collar nut

Tightening torque 5 Nm (3.7 ftlb.) +/- 0.75 Nm (0.6 ftlb.)

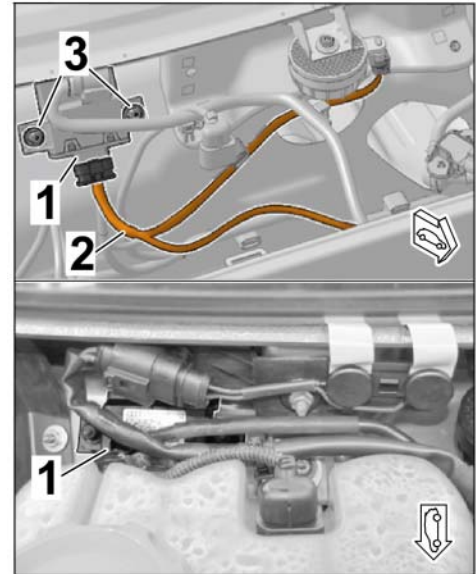

Figure 19

NOTICE

Incorrect line routing

- Risk of damage to lines and hoses
 - Malfunction and fault memory entry on control unit
- \Rightarrow Avoid small bending radii when routing lines.
- \Rightarrow File down edges and burrs in the routing area or mask them with adhesive tape.
- \Rightarrow Maintain a sufficient distance from components exposed to high temperatures while driving.

2.3 Install engine noise pulse sender (\Rightarrow Figure 20)



Information

Check that the electric line for the plug connection for the engine noise pulse sender is routed correctly.

- The line must **NOT** be touching the engine noise pulse sender holder (on the body side)!

- Route the line differently if necessary and use a tie-wrap to secure the line to existing lines or holders without tensile stress and so that no chafing or rattling occurs.

2.3.1 Route branch with connector (2-pin) to the engine noise pulse sender holder (⇒ *Figure 20-top*).

- 1 – Branch with connector (2-pin)
- 2 – Engine noise pulse sender
- 3 – Hexagon collar nut, M6
- 4 – Cable clip

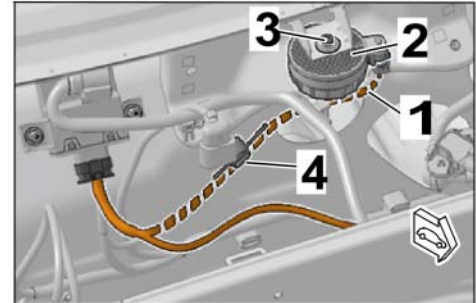

2.3.2 Connect plug connection for wire harness for engine noise control unit/pulse sender to the engine noise pulse sender (2-pin).

2.3.3 Guide pin on underside of engine noise pulse sender into the bore on the holder in the plenum panel.

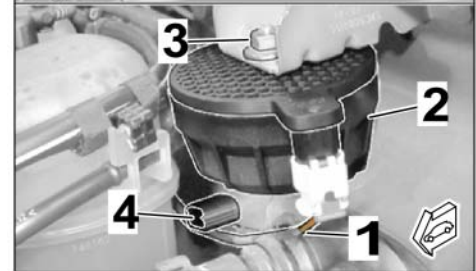

Figure 20

Secure engine noise pulse sender, facing downwards, in the plenum panel holder using M6 hexagon collar nut (1 x) (⇒ *Figure 20*)

Tightening torque 5 Nm (3.7 ftlb.) +/- 0.75 Nm (0.6 ftlb.)

2.3.4 Install cable clip on bulkhead stud (⇒ *Figure 20-4*).

2.4 Route electric wire harness for engine noise control unit/pulse sender

Wire harness connections – left-hand drive vehicles (⇒ *Figure 21*)

- 1 – Engine noise control unit connector (6-pin)
- 2 – Engine noise pulse sender connector (2-pin)
- 3 – Line clip
- 4 – Socket contacts for CAN lines ⇒ connector (17-pin, white)
- 5 – Pin contacts for CAN lines ⇒ plug socket (2-pin)
- 6 – Socket contact for terminal 15 ⇒ plug socket (3-pin, adapter cable)
- 7 – Cable ring eyelet A6 ⇒ A-pillar ground pins

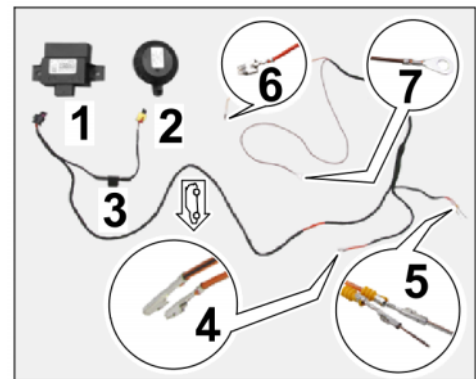

Figure 21

2.4.1 Carefully secure all contacts (⇒ *Figure 21 -4 to 7-*) to the wire harness for engine noise control unit/pulse sender using wrapping tape.

2.4.2 Route wire harness to the fuse box (E-box) in the cowl panel as follows:

- 1 – Engine noise control unit
- 2 – Engine noise pulse sender
- 3 – Coolant reservoir
- 4 – Brake booster
- 5 – Sleeve on fuse box (E-box)

- **Left-hand drive:** (⇒ *Figure 22*) Engine noise control unit/pulse sender → underneath coolant reservoir → underneath brake booster → sleeve on fuse box (E-box) in cowl panel (left side)

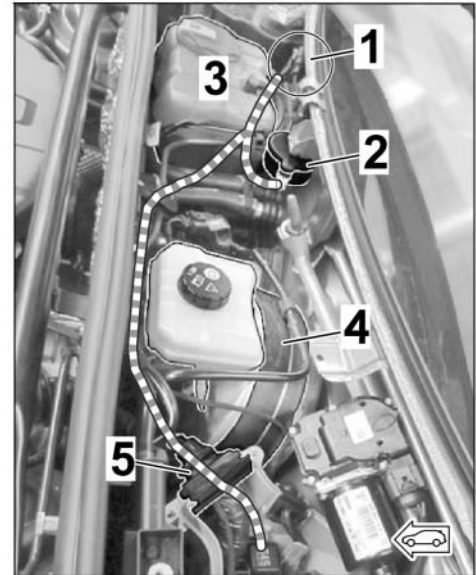

Figure 22

2.4.3 Secure wire harness for engine noise control unit/pulse sender to existing lines/components with tie-wraps without tensile stress and so that no chafing occurs.

2.4.4 Remove sleeve from fuse box (E-box) in cowl panel and cut off pre-shaped cone (repair opening) (⇒ *Figure 23*).

- 1 – Grommet
- 2 – Fuse box (E-box)

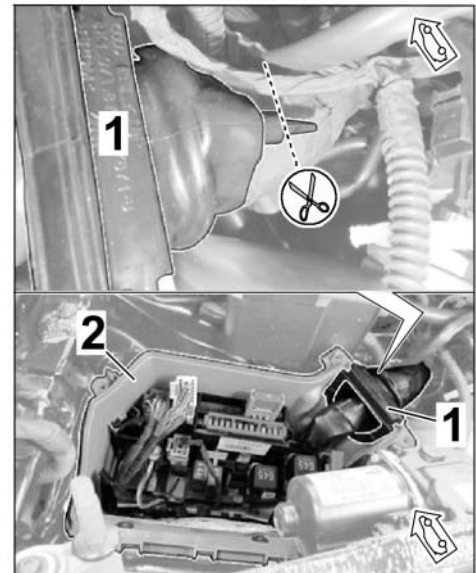

Figure 23

**Information**

Use three-mandrel pliers for hoses and sleeves (commercially available) if necessary.

- 2.4.5 Carefully guide wire harness for engine noise control unit/pulse sender through the new opening (sleeve) into the fuse box (E-box) (⇒ *Figure 24*).

- 1 – Wire harness for engine noise control unit/pulse sender
- 2 – Sleeve (fuse box – E-box)
- 3 – Branch for CAN lines
- 4 – Branch for power supply/ground
- 5 – Opening on bulkhead

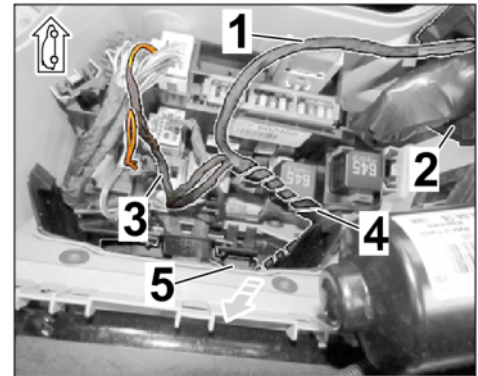

Figure 24

- 2.4.6 Seal wire harness in the sleeve using inner/outer sealing cord and install sleeve in the fuse box in the cowl panel.

- 2.4.7 Route branch for power supply/ground (line BN; 1.0² with cable ring eyelet and line RD/YE; 1.0²) from wire harness for engine noise control unit/pulse sender) to the passenger compartment as follows (⇒ *Figure 25*):

- 1 – Branch for power supply/ground
 - 2 – Ground pin 21 (left-hand drive)
 - 3 – Fuse strip A
- Fuse box (E-box) in cowl panel
→ above fuses/relays →
through opening on bulkhead
→ fuse/relay carrier on A-pillar
(on driver's side)

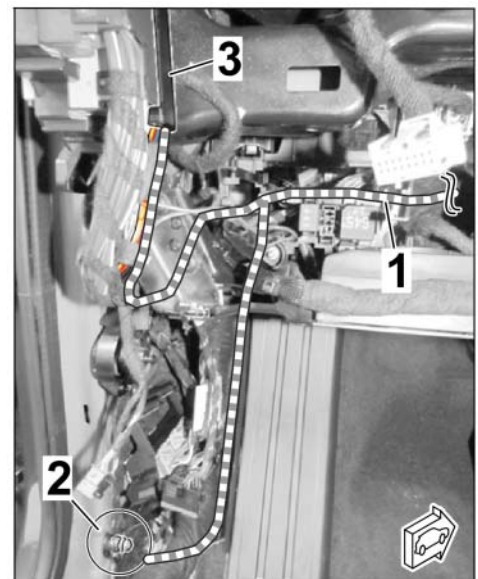

Figure 25

- 2.5 Connect CAN lines of electric wire harness for engine noise control unit/pulse sender

- 2.5.1 Take connector housing and plug socket (2-pin) for CAN lines out of the bag of small parts.

Insert a small screwdriver between the pin connector socket and connector housing (⇒ *Figure 26 -a-*).

- 1 - Pin connector socket (2-pin)
- 2 - Connector housing (2-pin)

Carefully lift up connector housing (⇒ *Figure 26 -b-*) and pull out pin connector socket.



Information

CAN lines must be twisted properly!

Manually re-twist untwisted lines at plug connections/splice greater than 50 mm/ 1.97 in.

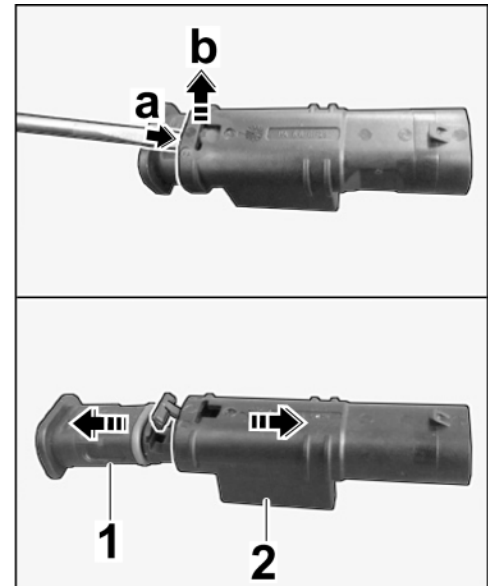

Figure 26



Information

Observe markings on the housing!

2.5.2 Connect CAN lines with pin contact/single-wire seal (wire harness for engine noise control unit/pulse sender) in the pin connector socket as follows (⇒ *Figure 27*):

- 1 - OG/BN line ⇒ chamber 1 (pin connector socket)
- 2 - OG/BK line ⇒ chamber 2 (pin connector socket)
- 3 - Connector (2-pin)

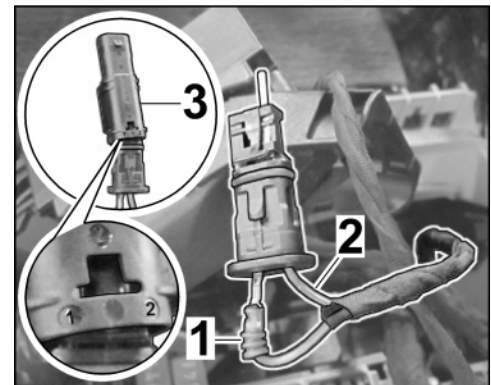

Figure 27

Function/line:	Pin connector socket (2-pin)
Control CAN drive LOW = OG/BN; 0.35 ²	⇒ insert into chamber 1 of pin connector socket (2-pin)
Control CAN drive HIGH = OG/BK; 0.35 ²	⇒ insert into chamber 2 of pin connector socket (2-pin)

Install pin connector socket (2-pin) back into the connector housing.

- 2.5.3 Release (2-pin) plug socket
(⇒ *Figure 28*).

- 1 – Plug socket (2-pin)
- 2 – Secondary lock

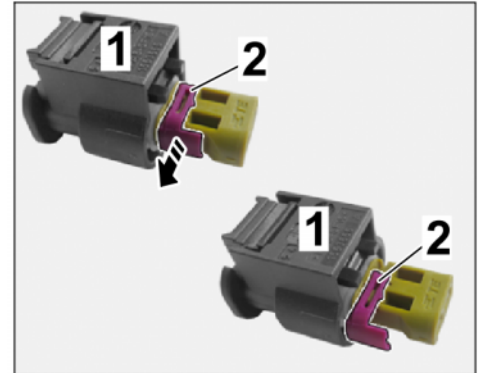

Figure 28

- 2.5.4 Remove and release connector
(17-pin, white) from fuse/relay carrier (E-box, connection point
X372.1A1) (⇒ *Figure 29*).

- 1 – Connector (17-pin, white)
- 2 – Fuse/relay carrier (E-box)
- 3 – Secondary lock

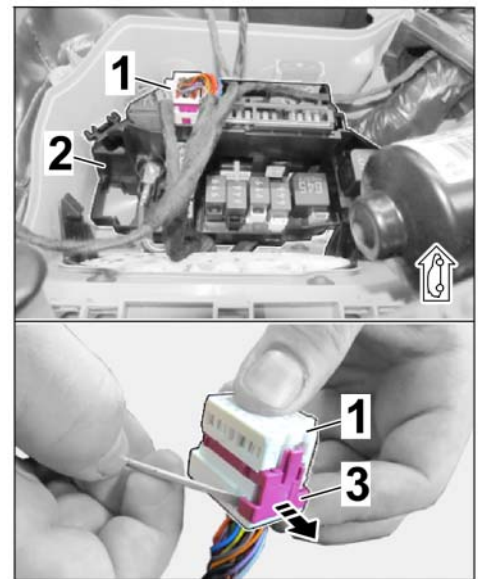

Figure 29

2.5.5 Change pin assignment of lines OG/BN / OG/BK in the connector (17-pin, white) as follows (⇒ *Figure 30*):

- 1 – Connector (2-pin)
- 2 – Socket (2-pin)
- 3 – Connector (17-pin, white)
- 4 – Wire harness for engine noise control unit/pulse sender
- 5 – Vehicle wire harness

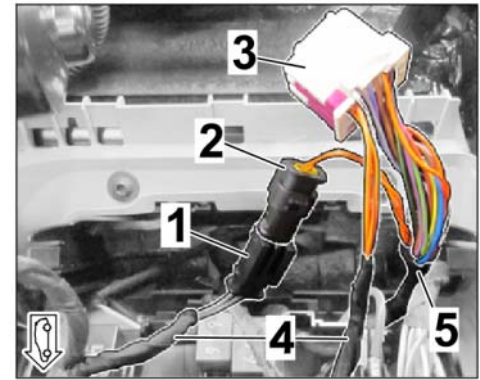

Figure 30

Function/line:	Connector (17-pin, white)
Control CAN drive LOW = OG/BN; 0.35 ²	Unpin socket from chamber 13 ⇒ Insert into chamber 1 of plug socket (2-pin ⇒ <i>Figure 28</i>)
Control CAN drive HIGH = OG/BK; 0.35 ²	Unpin socket from chamber 14 ⇒ Insert into chamber 2 of plug socket (2-pin ⇒ <i>Figure 28</i>)

Lock the plug socket (black, 2-pin) (⇒ *Figure 28*).

2.5.6 Insert socket for lines OG/BN / OG/BK (wire harness for engine noise control unit/pulse sender) into the connector (white, 17-pin) as follows:

Function/line:	Wire harness (engine noise control unit/pulse sender)
Control CAN drive LOW = OG/BN; 0.35 ²	Socket ⇒ insert into chamber 13 of connector (17-pin, white ⇒ <i>Figure 30-3-</i>)
Control CAN drive HIGH = OG/BK; 0.35 ²	Socket ⇒ insert into chamber 14 of connector (17-pin, white ⇒ <i>Figure 30-3-</i>)

Lock the connector (17-pin, white) and install it in the fuse box (connection point X372.1A1).

2.5.7 Connect plug connection (2-pin) (⇒ *Figure 30-1 & 2-*).

2.6 Connect adapter cable with connector (3-pin) to terminal 15 and install it

2.6.1 Disconnect plug connection (3-pin) of adapter cable and release/open plug socket (3-pin) (\Rightarrow *Figure 31*).

- 1 – Adapter cable with connector (3-pin)
- 2 – Plug socket (3-pin)
- 3 – Line RD/YE; 1.0² with socket \Rightarrow fuse strip A, chamber 3A

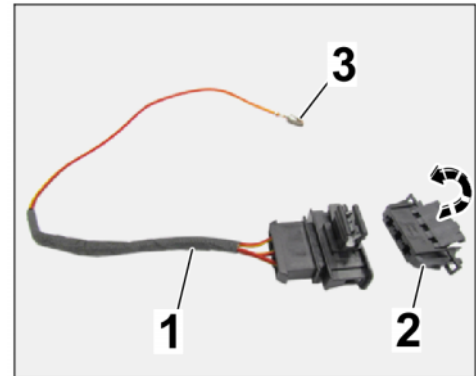

Figure 31

2.6.2 Release fuse strip A (black) using a screwdriver and remove it by pulling it to the rear and out of the fuse carrier (A-pillar area) (\Rightarrow *Figure 32*).

- 1 – Fuse strip A (black)
- 2 – Cover

Release cover (\Rightarrow *Figure 32-2-*) on fuse strip A (black) at both sides and remove it.

Open secondary lock on fuse strip A (black) (\Rightarrow *Figure 32-B-*).

2.6.3 Remove wrapping tape from standard wire harness (\Rightarrow *Figure 32-3-*).

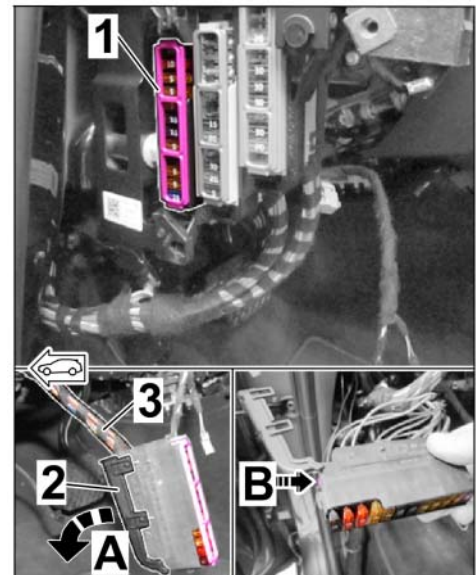

Figure 32

2.6.4 Assign plug socket (3-pin) as follows (⇒ *Figure 33*):

- 1 – Line RD/YE; 1.0² (in vehicle)
- 2 – Fuse strip A
- 3 – Line RD/YE; 1.0² (wire harness for engine noise control unit/pulse sender)
- 4 – Plug socket (3-pin)
- 5 – Pin connector socket (3-pin)

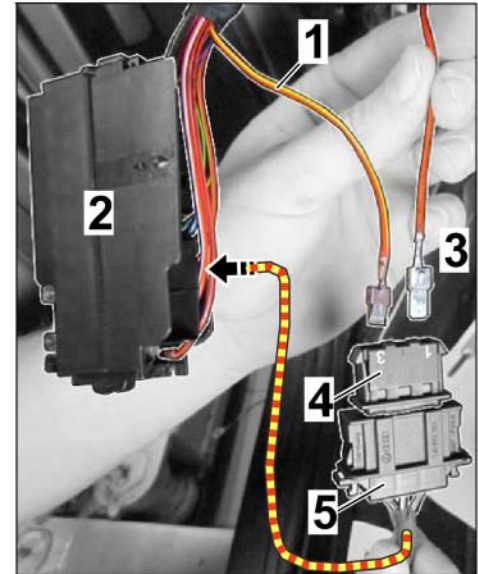

Figure 33

Function/line:	Plug socket (3-pin)
Terminal 15 RD/YE; 1.0 ²	Unpin line (in the vehicle ⇒ <i>Figure 33-1-</i>) with socket from fuse strip A, chamber 3A ⇒ insert into chamber 1 of plug socket (3-pin)
Terminal 15 RD/YE; 1.0 ²	Line (wire harness for engine noise control unit/pulse sender ⇒ <i>Figure 33-3-</i>) ⇒ Insert into chamber 3 of plug socket (3-pin)

2.6.5 Lock plug socket (3-pin) and wind wrapping tape around both lines RD/YE; 1.0².

2.6.6 Insert line RD/YE; 1.0² with socket from pin connector socket (black, 3-pin) into fuse strip A, chamber 3A.

2.6.7 Close secondary lock on fuse strip A (black).

Install cover on fuse strip A (black) and install fuse strip A (black) in the fuse carrier (A-pillar area).

2.6.8 Install pin connector socket (3-pin) with clip onto the dashboard bracket and connect plug connection (3-pin) (\Rightarrow *Figure 34*).

- 1 – Connector (3-pin)
- 2 – Dashboard bracket

2.6.9 Secure adapter cable to existing lines/components with tie-wraps without tensile stress and so that no chafing occurs.

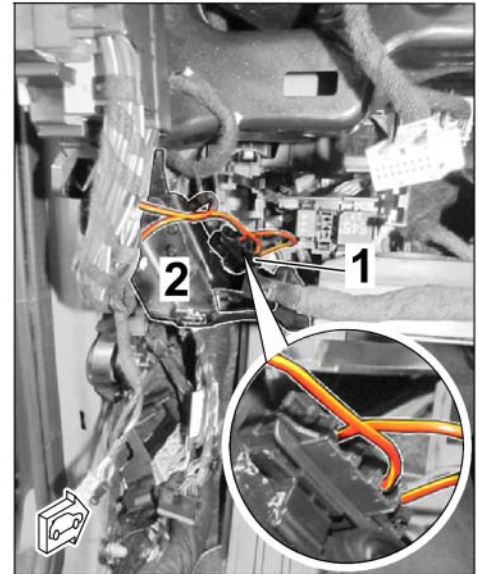

Figure 34

2.7 Route line BN; 1.0² with cable shoe (ground) to the ground pin MB 21 (left-hand drive) and install it (\Rightarrow *Figure 35*).

- 1 – Line BN 1.0² with cable shoe (ground)
- 2 – Ground pin 21 (left-hand drive)

Tightening torque 9 Nm (6.6 ftlb.)

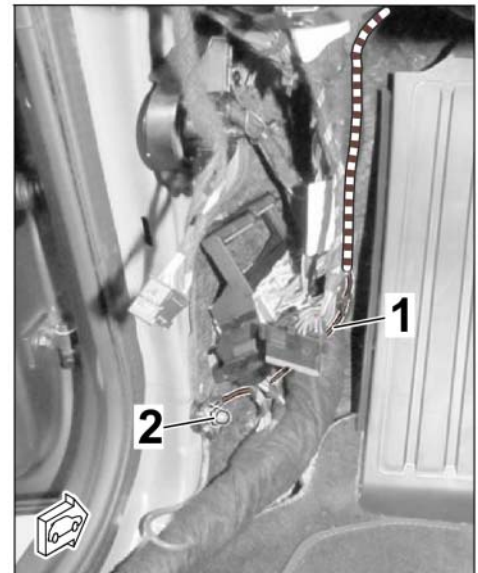

Figure 35

- 3 Route and connect wire harness for connection point/exhaust flap
 - 1 – Pin connector socket (2-pin) with socket contact ⇒ connector (17-pin, red)
 - 2 – Cable ring eyelet A6 ⇒ ground pin 43
 - 3 – Connector (3-pin) ⇒ exhaust flap on rear silencer, right
 - 4 – Plug socket (2-pin) ⇒ pin connector socket (2-pin)
 - 5 – Socket contact, line VT/GN; 0.5² ⇒ connector (17-pin, red)

– Wire harness connections (⇒ *Figure 36*):

- 3.1 Install ground line BN; 0.5² with cable ring eyelet A6

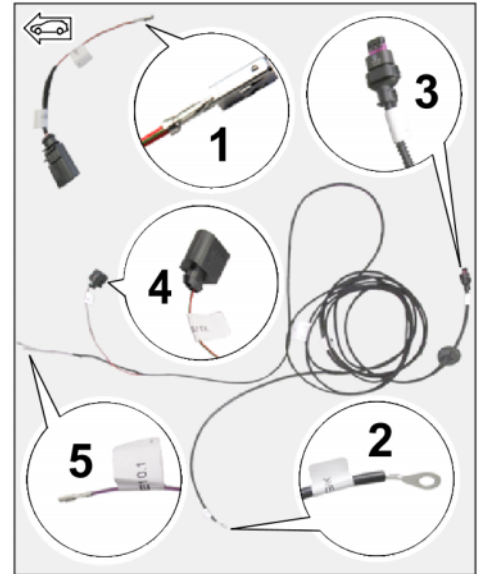

Figure 36

- 3.1.1 **ONLY** vehicles with Burmester® High-End Surround Sound System (9VJ):
Loosen the speaker amplifier and swing it aside. ⇒ *Workshop Manual '914419 Removing and installing loudspeaker booster'*

- 1 – Loudspeaker booster
- 2 – Ground pin 43
- 3 – Line BN; 0.5²

- 3.1.2 Route branch of line BN; 1.0² with cable ring eyelet A6 (ground) above the (left) wheel housing to the ground pin MB 43.

- 3.1.3 Install cable ring eyelet A6 (ground) on ground pin MB 43 (⇒ *Figure 37*)

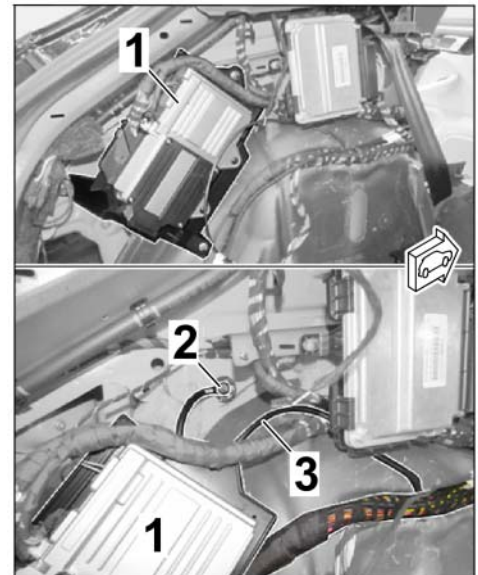

Figure 37

Tightening torque 9 Nm (6.6 ftlb.)

- 3.1.4 **ONLY** vehicles with Burmester® High-End Surround Sound System (9VJ):
Install loudspeaker booster. ⇒ *Workshop Manual '914419 Removing and installing loudspeaker booster'*

3.2 Route branch for exhaust flap (right) as follows:

- 1 – Ground pin 43
- 2 – Wheel housing liner (left)
- 3 – Rear closing panel
- 4 – Branch for exhaust flap (right)
- 5 – Branch for connection point

- Ground pin 43 (⇒ *Figure 38-1-*) → main wire harness above wheel housing liner (left ⇒ *Figure 38-2-*) → along main wire harness → rear closing panel (⇒ *Figure 38-3-*) → fuse/relay carrier (rear right ⇒ *Figure 39-3-*)

Detach fuse/relay carrier (rear right) if necessary (⇒ *Figure 39-3-*)

- 1 – Branch for exhaust flap (right)
- 2 – Adhesive pad
- 3 – Fuse/relay carrier (rear right)

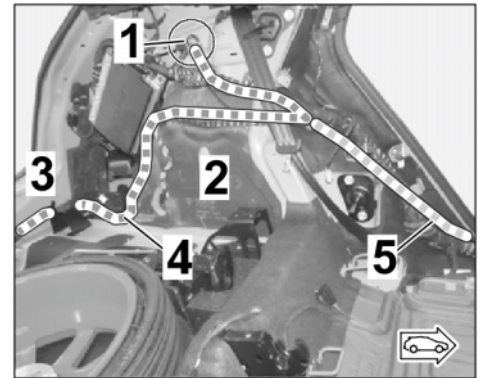

Figure 38

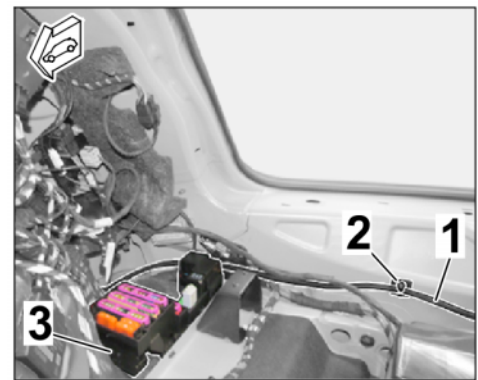

Figure 39

3.3 Guide connector (3-pin) through the bore to the underside of the vehicle and install sleeve into the bore (⇒ *Figure 40*).

- 1 – Grommet
- 2 – Branch for exhaust flap (right)
- 3 – Fuse/relay carrier (rear right)
- 4 – Bumper (rear right)

3.4 Route branch for connection point to the fuse box (E-box) in the cowl panel as follows:

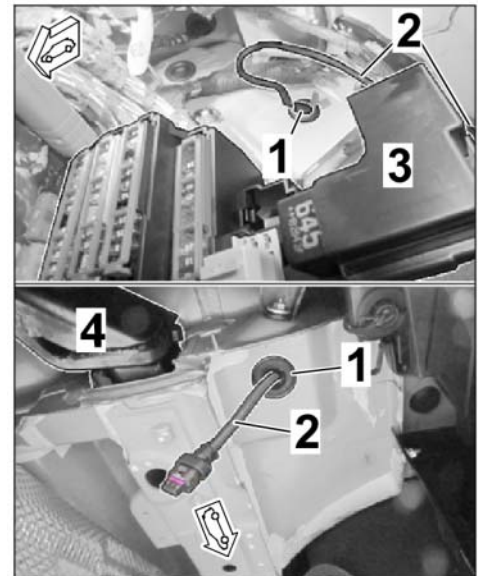

Figure 40

3.4.1 **ONLY** for left-hand drive vehicles (⇒ *Figure 41*):

Arrow – Ground pin 43

- Ground pin 43 → door sill at C-pillar (left) → door sill at B-pillar (left) → A-pillar (left) → opening on bulkhead (left) → fuse box (E-box) in cowl panel (left)

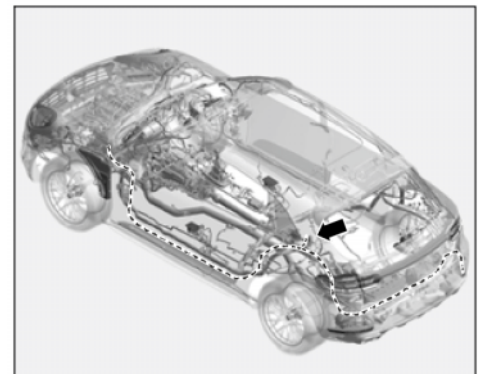

Figure 41

3.5 Connect branch for connection point

3.5.1 Remove and release connector (17-pin, red) from fuse/relay carrier (E-box, connection point X371.1A1) (⇒ *Figure 44*).

- 1 – Connector (17-pin, red)
- 2 – Fuse/relay carrier (E-box)
- 3 – Secondary lock

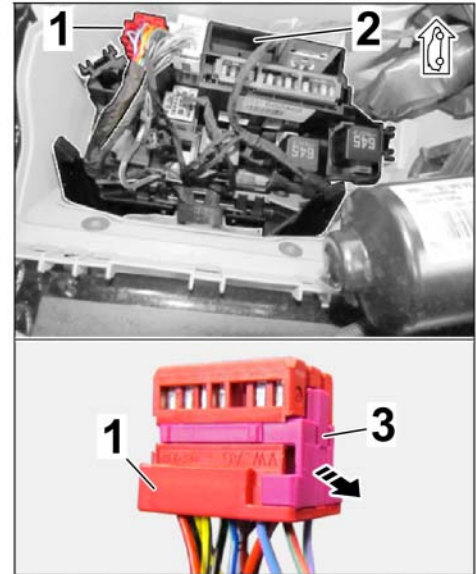

Figure 44

3.5.2 Change pin assignment of RD/GN and VT/GN lines in the connector (17-pin, red) and insert as follows:

- 1 – Connector (17-pin, red)
- 2 – Plug socket (2-pin)
- 3 – Pin connector socket (2-pin)
- 4 – Line VT/GN; 0.5² (wire harness for connection point/exhaust flap)
- 5 – Line RD/GN; 0.5²

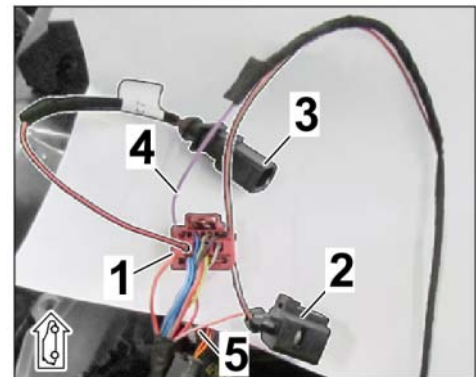

Figure 45

Function / line:	Connector (17-pin, red)
Terminal 87A (supply) Exhaust flap (new) = RD/GN; 0.5 ²	Unpin socket from chamber 17 ⇒ Insert into chamber 2 of plug socket (2-pin ⇒ <i>Figure 45-2-</i>)
Terminal 87A (supply) Exhaust flap (new) = RD/GN; 0.5 ²	Socket of pin housing (2-pole, black) ⇒ plug into chamber 17 connector (17-pin, red ⇒ <i>Figure 45-1-</i>)
Control Status Exhaust flap (new) = VT/GN; 0.5 ²	Bushing of line set coupling point / exhaust flap ⇒ plug into chamber 14 connector (17-pin, red ⇒ <i>Figure 45-1-</i>)

- 3.5.3 Connect plug connection (2-pin).
- 3.6 Secure plug connections (CAN lines/terminal 87A) to existing lines/components in the fuse box (E-box) in the cowl panel with tie-wraps without tensile stress and so that no chafing occurs (⇒ *Figure 46*).

- 1 – Plug connection (terminal 87A)
- 2 – Plug connection (CAN lines)
- 3 – Tie-wrap

- 3.7 Secure routed wire harness for connection point/exhaust flap in the vehicle to existing lines/components with tie-wraps without tensile stress and so that no chafing occurs.

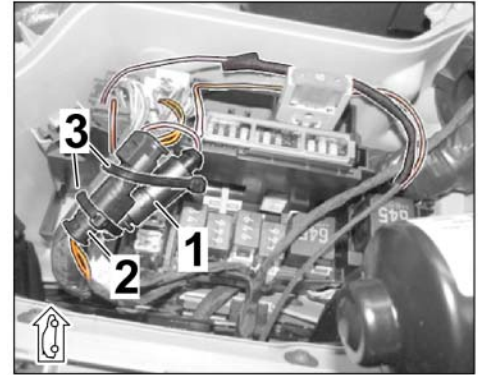

Figure 46

Secure extra length of line if necessary.

4 Concluding work in vehicle interior

4.1 Assemble luggage compartment/C-pillar area

- 4.1.1 Install the sill trim on the inside rear (driver's side). ⇒ *Workshop Manual '680519 Removing and installing rear inner door sill trim'*
- 4.1.2 **ONLY** for vehicles with spare wheel (space-saving – 1G1 / 1G4):
Remove compressor tool kit.
- 4.1.3 Installing (side) luggage compartment trim panel (luggage compartment cover).
⇒ *Workshop Manual '700619 Removing and installing side luggage compartment trim (luggage compartment cover)'*
- 4.1.4 Install side trim panel for rear luggage compartment (at the left / right). ⇒ *Workshop Manual '700319 Removing and installing side trim panel for rear luggage compartment'*

4.2 Assemble B-pillar area (on driver's side)

- 4.2.1 Install lower part of B-pillar trim panel (on driver's side). ⇒ *Workshop Manual '70671903 Removing and installing lower part of B-pillar trim panel'*
- 4.2.2 Install upper part of B-pillar trim panel (on driver's side). ⇒ *Workshop Manual '706719 Removing and installing upper part of B-pillar trim panel'*
- 4.2.3 Install rear seat. ⇒ *Workshop Manual '724819 Removing and installing rear seat'*
- 4.2.4 Secure/install rear backrest. ⇒ *Workshop Manual '724719 Removing and installing rear backrest'*

Secure belt installing on 1/3-split folding seat backrest using an flat screw with internal serration.

Tightening torque 50 Nm (36.9 ftlb.)

- 4.2.5 Place items in luggage compartment and install luggage compartment cover.
- 4.3 Assemble A-pillar area (on driver's side)
- 4.3.1 Install front inner door sill trim. ⇒ *Workshop Manual '680519 Removing and installing front inner door sill trim'*
- 4.3.2 Install trim panel under dashboard. ⇒ *Workshop Manual '701919 Removing and installing trim panel under dashboard on driver's side'*
- 4.3.3 Install dashboard moulding/trim panel (at the right). ⇒ *Workshop Manual '70581902 Removing and installing dashboard moulding on driver's side (right)'*
- 4.3.4 Install air vent (on instrument cluster) and air vent unit (underneath the PCM).
- 4.3.5 Install dashboard trim panel. ⇒ *Workshop Manual '701619 Remove and install dashboard trim panel'*
- 4.4 Assemble plenum panel area
- 4.4.1 Install foam pads on bulkhead (⇒ *Figure 47-2-*).
- 1 – Fuse box (E-box) in cowl panel
- 2 – Foam pads on bulkhead
- 4.4.2 Installing fuse box cover (E-box) on cowl panel (⇒ *Figure 47*).
⇒ *Workshop Manual '978409 Loosening and securing fuse box'*
- 4.4.3 Installing cowl panel cover. ⇒ *Workshop Manual '508719 Removing and installing cowl panel cover'*
- 4.4.4 Installing wiper arms. ⇒ *Workshop Manual '922519 Removing and installing wiper arm'*
- 4.4.5 Removing front lid service position. ⇒ *Workshop Manual '552213 Securing front lid (service position)'*
- 5 Installing new exhaust system
- 5.1 Position and secure heat insulation in the rear silencer area – on the right.

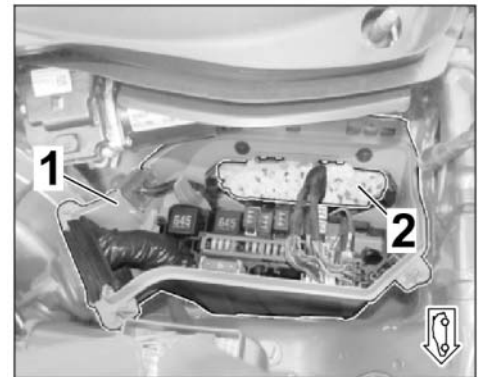

Figure 47

Tightening torque 2 Nm (1.5 ftlb.)

5.2 Install new rear silencers (⇒ Figure 48).

- 1 – Exhaust pipe
- 2 – Clamping sleeve, Ø 65 x 88
- 3 – Rear silencer (left)
- 4 – Rear silencer (right)
- 5 – Hexagon-head bolt, M8 x 40

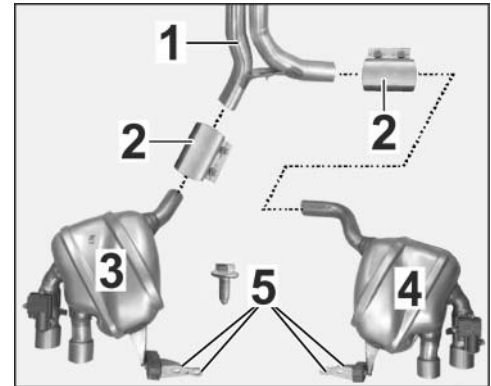

Figure 48

5.2.1 Install new clamping sleeve (Ø 65 x 88, 2 x) on the exhaust pipe.

5.2.2 Pre-mount new rear silencer (left / right) hand-tight. ⇒ *Workshop Manual '263355 Replacing rear silencer'*

5.2.3 Establish electrical plug connection at the actuators of the exhaust flaps of the left and right rear silencers. ⇒ *Workshop Manual '265119 Removing and installing exhaust flap actuator'*

5.3 Install new sports tailpipes (⇒ Figure 49).

5.3.1 Carefully guide sports tailpipes (left/right) through the cut-out on the rear apron and as far as they will go onto the rear silencer connection piece.



Figure 49



Information

The tailpipes are adjusted in X direction using the slots in the tailpipe.

5.3.2 Check projection of tailpipe cover on sports tailpipes (left/right) and cover on exhaust system (rear apron) and adjust evenly.

Align the complete exhaust system if necessary.

5.3.3 Tighten countersunk screw M6 x 12 (on underside of cover on sports tailpipe).

Tightening torque 8 Nm (5.9 ftlb.) +/- 1 Nm (0.7 ftlb.)

5.4 Tighten all threaded connections on the exhaust system fully to the specified torque. ⇒ *Workshop Manual '2X00IN Technical values (R4)'*

Coding: 6 Entering the sports exhaust system (OP8 or OP9) in the vehicle data

NOTICE**Voltage drop**

- Risk of irreparable damage to control unit
 - Risk of damage to control unit
 - Fault entries in the control unit
 - Coding in the control unit is aborted
 - Malfunctions in control unit, even during programming
- ⇒ Switch off the ignition and remove the ignition key before disconnecting the control unit.
- ⇒ Ensure that the power supply is not interrupted during programming.
- ⇒ Connect a battery charger with a current rating of at least Nominal value 90 A to the vehicle battery.

6.1 Preliminary work

NOTICE

Control unit programming will be aborted if the Internet connection is unstable.

- An unstable Internet connection can interrupt communication between PIWIS Tester III and the vehicle communication module (VCI). As a result, control unit programming may be aborted.
- ⇒ During control unit programming, always connect PIWIS Tester III to the vehicle communication module (VCI) via the USB cable.

6.1.1 **9900 - PIWIS Tester 3** must be connected to the vehicle and switched on.

6.1.2 Switch on ignition **AND** hazard warning lights on the vehicle.

**Information**

The **9900 - PIWIS Tester III** instructions take precedence since the description may be different with later Tester releases.

The procedure described here has been structured in general terms; different text or additions may appear on the **9900 - PIWIS Tester III**.

6.1.3 Select the "Diagnostics" menu item on the PIWIS Tester.

6.1.4 If **9900 - PIWIS Tester 3** is connected correctly, a connection to the vehicle will be established: "Macan model line" is detected.

- 6.2 Enter the new vehicle equipment in the vehicle data
 - 6.2.1 Press **•F7** in the control unit overview to switch to the "Additional menu".
Question "Should a Vehicle Analysis Log (VAL) be created?" Press **•F12** to confirm.
 - 6.2.2 Select the "Maintenance of vehicle data" function. Press **•F12** until "PR numbers" appears in the Value group column.
 - 6.2.3 Look for the option "INTERIOR SOUND MEASURES (SILENCERS)" in the "Family" column.

Select the option "2HB – INTERIOR SOUND MEASURES (SHAKER)" from the drop-down menu in the "Value" column.
 - 6.2.4 Look for the option "EXHAUST TAILPIPE" in the "Family" column.

Select the required option "OP8 – SPORTS EXHAUST SYSTEM – STAINLESS-STEEL TAILPIPES" or "OP9 – SPORTS EXHAUST SYSTEM – BLACK TAILPIPES" from the drop-down menu in the "Value" column.
 - 6.2.5 Press **•F12** to continue. A table containing coding values (old and new value) is displayed in the overview.
 - 6.2.6 Press **•F8** to continue. Data is then written/stored.
 - 6.2.7 Wait for the message "Creation of vehicle data has been completed." to be displayed. Press **•F12** to go to Report management.
 - 6.2.8 Press **•F10** to open the log. Check that the selected vehicle equipment has been entered and close the log.
- 6.3 Code/program the new vehicle equipment.
 - 6.3.1 Select **ALL** control units (**•CTRL+A**) in the control unit overview and switch to the "Coding/programming" column.
 - 6.3.2 Select the coding mode "Automatic coding". Press **•F12** to continue.
 - 6.3.3 Once "Automatic coding" is complete, the message "Coding was completed successfully. Press **•F12** to continue."

Switch to the control unit overview.
- 6.4 Select the fault memory of all systems, work through any existing faults, and erase the fault memory. ⇒ *Workshop Manual 'OX03IN Diagnostic maintenance: Diagnostic system and maintenance inter...'*
- 6.5 Perform function test on engine noise pulse sender
 - 6.5.1 Look for and select "Control unit for interior acoustics" in the control unit overview. Then select the "Drive links/checks" tab.
 - 6.5.2 Then select "Sound symposer activation". Press **•F12** to continue.

6.5.3 Press **•F8** to execute function test. If the test is successful, the following information will be displayed:

- Results column: "Successful output without return value"
- Value column: "active".

You will also hear an increasing acoustic signal.

6.5.4 Go back to the control unit overview by pressing **•F11**

6.6 Switch off ignition and disconnect **9900 - PIWIS Tester 3**.

6.7 Perform "Sports exhaust system" function test

6.7.1 Switch on ignition and check the display for the new "Twin tailpipe" symbol (see inset, Figure 1) in the center console area.

6.7.2 Start the engine and switch the sports exhaust system on and off in the center console using the "Twin tailpipe button".

Compare the sound at idle speed and also with the accelerator pedals with the sports exhaust system switched on and off.

6.7.3 Perform a test drive and repeat 6.7.2.

You will hear a change in the noise level between the individual driving modes.

26 01 31 03:	-Retrofitting sports exhaust system (1 x)-	Labor time: 545 TU
Includes:	<ul style="list-style-type: none"> Install pulse sender and engine noise control unit; Route and connect electric wire harness; Replace rear silencer (left/right); Install and align new sports tailpipes (4 x); Code the sports exhaust system; Select fault memory, correct faults and delete them. 	
Without:	Test drive	

Important Notice: Technical Bulletins issued by Porsche Cars North America, Inc. are intended only for use by professional automotive technicians who have attended Porsche service training courses. They are written to inform those technicians of conditions that may occur on some Porsche vehicles, or to provide information that could assist in the proper servicing of a vehicle. Porsche special tools may be necessary in order to perform certain operations identified in these bulletins. Use of tools and procedures other than those Porsche recommends in these bulletins may be detrimental to the safe operation of your vehicle, and may endanger the people working on it. Properly trained Porsche technicians have the equipment, tools, safety instructions, and know-how to do the job properly and safely. Part numbers listed in these bulletins are for reference only. The work procedures updated electronically in the Porsche PIWIS diagnostic and testing device take precedence and, in the event of a discrepancy, the work procedures in the PIWIS Tester are the ones that must be followed.

© 2022 Porsche Cars North America, Inc.