









Hide Details

Coding Information

Copy Link 	Copy Relative Link 	Bookmark  View My Bookmarks	Add to Favorites 	Print 	Provide Feedback 	Helpful  2	Not Helpful  1
---	--	---	--	---	--	--	--

Title: PicoScope Test for Datalink (CAN) Health Shorts & Opens

Applies To: All International / IC and Other Makes & Models

CHANGE LOG

Please refer to the change log text box below for recent changes to this article:

08/19/2022 - Initial Article Release

DESCRIPTION

This procedure was created to guide a technician through proper diagnostic steps in diagnosing vehicles with datalink (CAN) concerns.

SYMPTOM(s)

Datalink concerns in relation to active, healing and or inactive fault codes. Intermittent operation related to ABS, BCM, ECM, IC, TCM and other modules in regards to potential wiring harness or hardware issues.

SPECIAL TOOL(s) / SOFTWARE

Tool Description	Tool Number	Comments	Instructions
PicoScope	1211210		
J1939 (9 PIN breakout box) or OBDII (16 PIN breakout box) if available			A breakout box is a helpful tool but is not an essential tool to diagnosis datalink (CAN) circuits.

DIAGNOSTIC STEP(s)

1. Use breakout box (BOB) or breakout tee or other method to connect the datalink.
 - a. Channel A - High to ground
 - b. Channel B - Low to ground

2. If monitoring two datalinks at the same time (500k and private CAN for example) then repeat above on channels C and D.

Note- private datalinks can be accessed via a breakout tee for a component that is on the private datalink

Figure 1: Test one Datalink

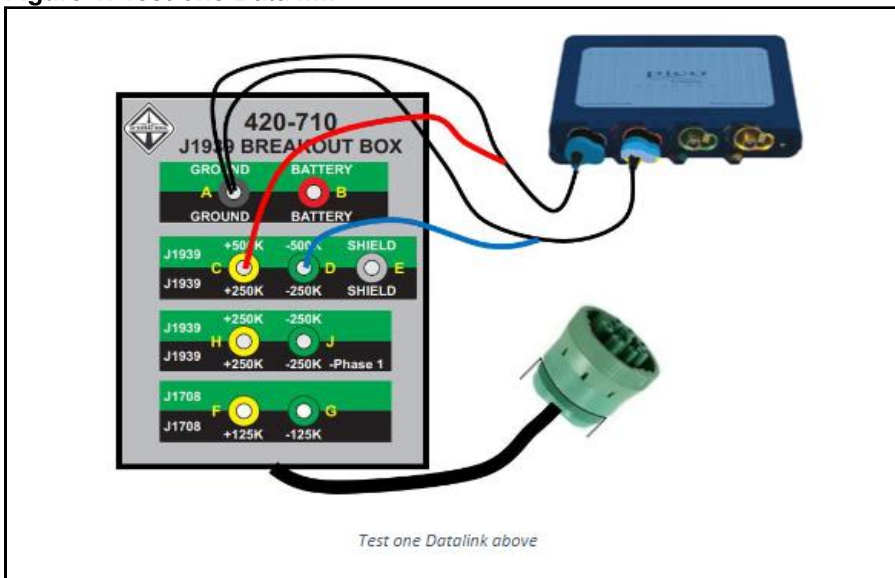
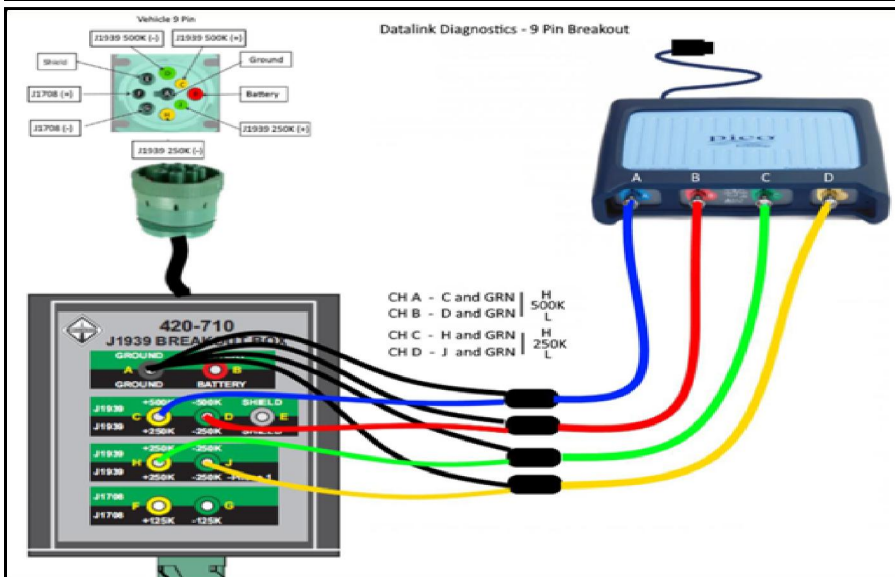

Figure 2: Testing multiple Datalinks



3. Open PicoScope software



4. Open folder and load Datalink Health setup file.

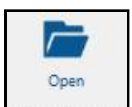

5. Connect PicoScope as defined in Figure 1

6. To begin operation move your cursor and tap on **RUNNING**.



7. Reproduce the concern by disconnecting modules, wiggle testing a wiring harness or road-testing a vehicle. After the concern has been identified move your cursor and tap on **STOPPED**.



8. Review recordings tap on **WAVEFORM** see examples below.

DATA ANALYSIS

Review each recording to help identify when a concern occurs by expanding out each graph and adjusting **time and division**.

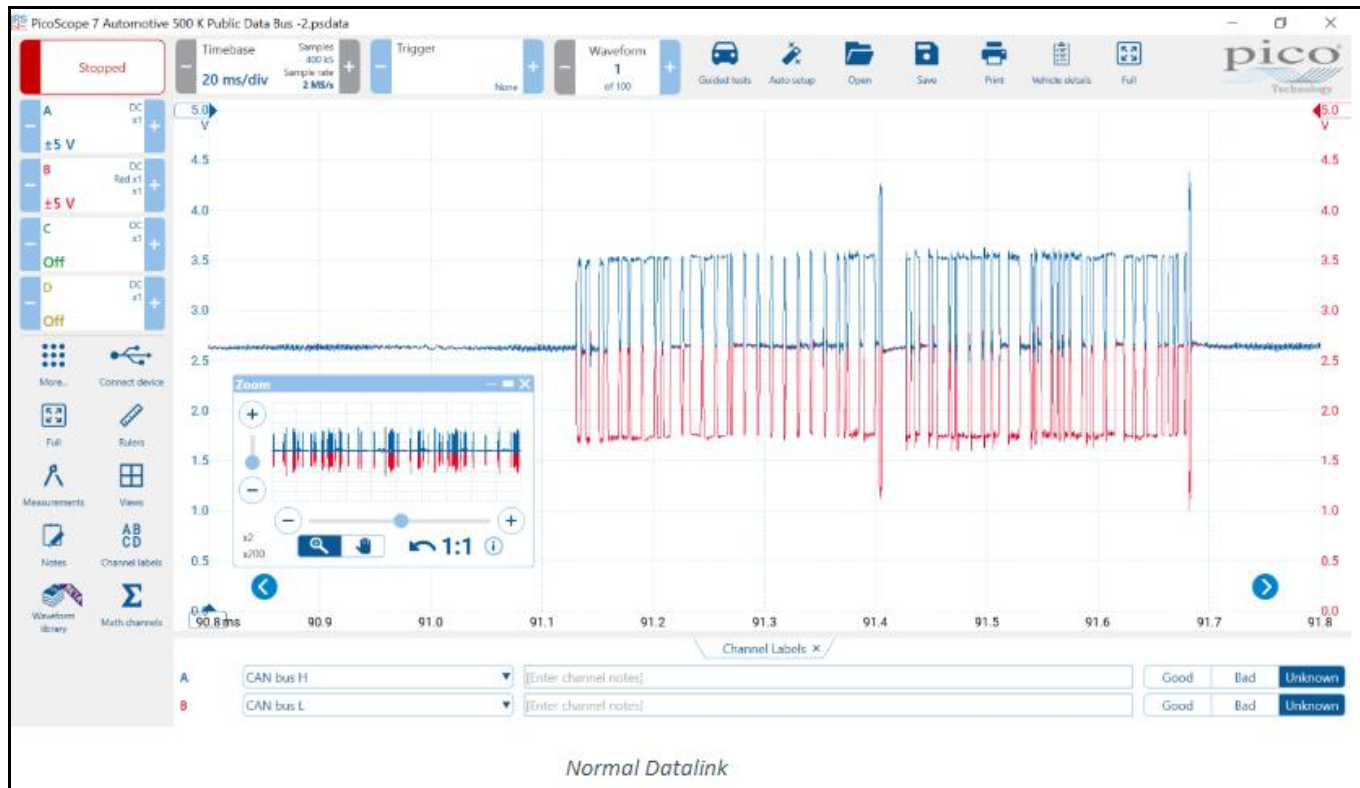
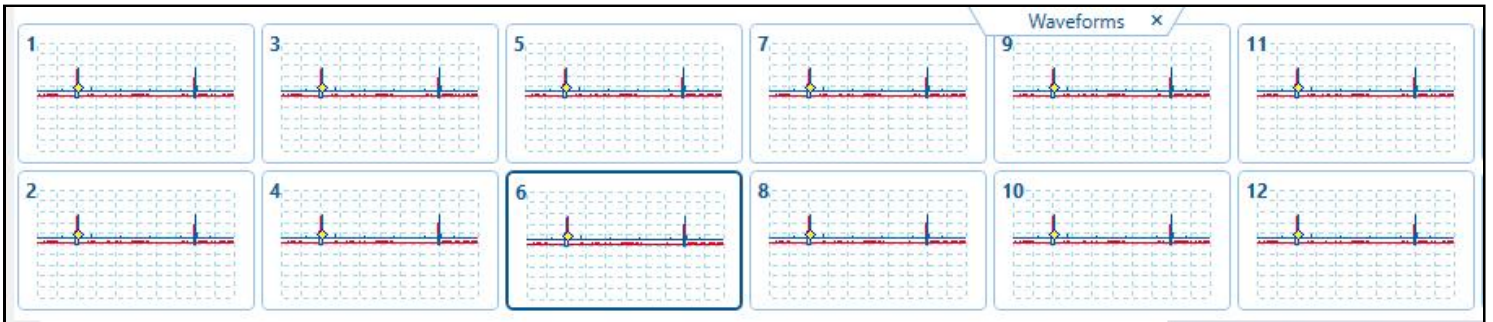

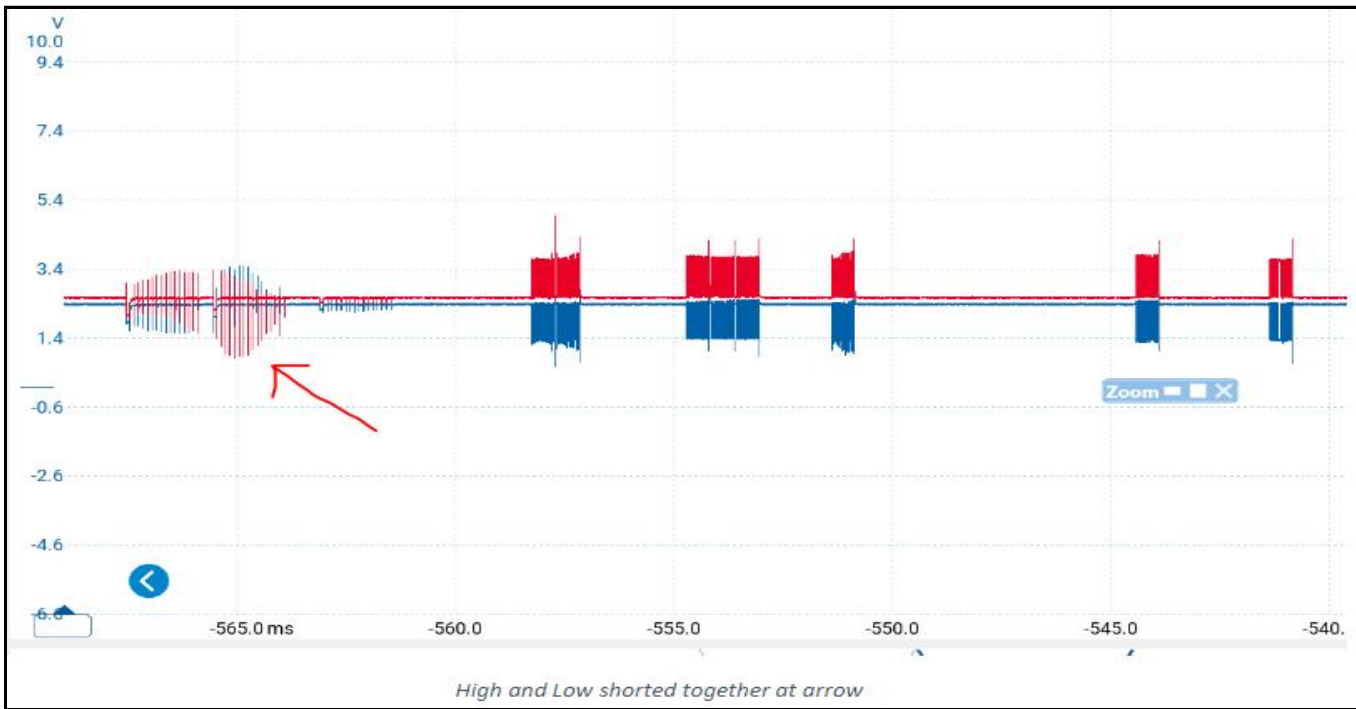

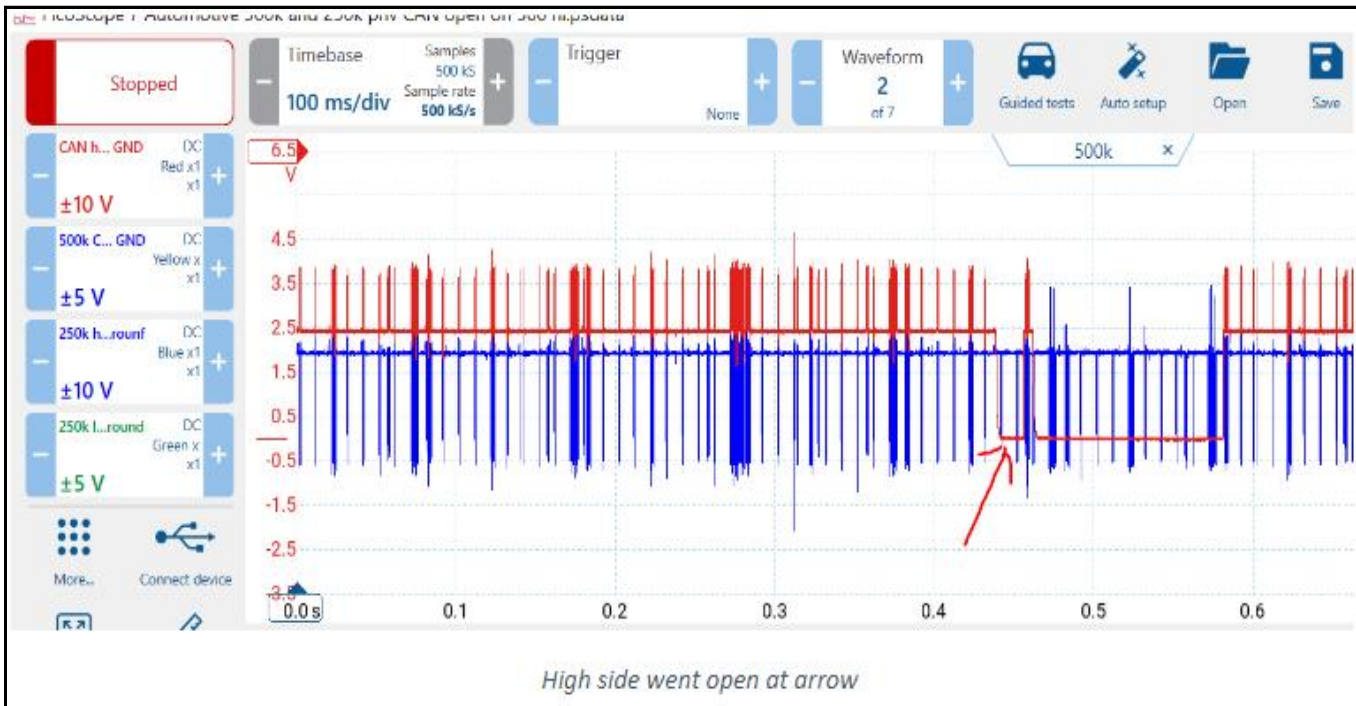
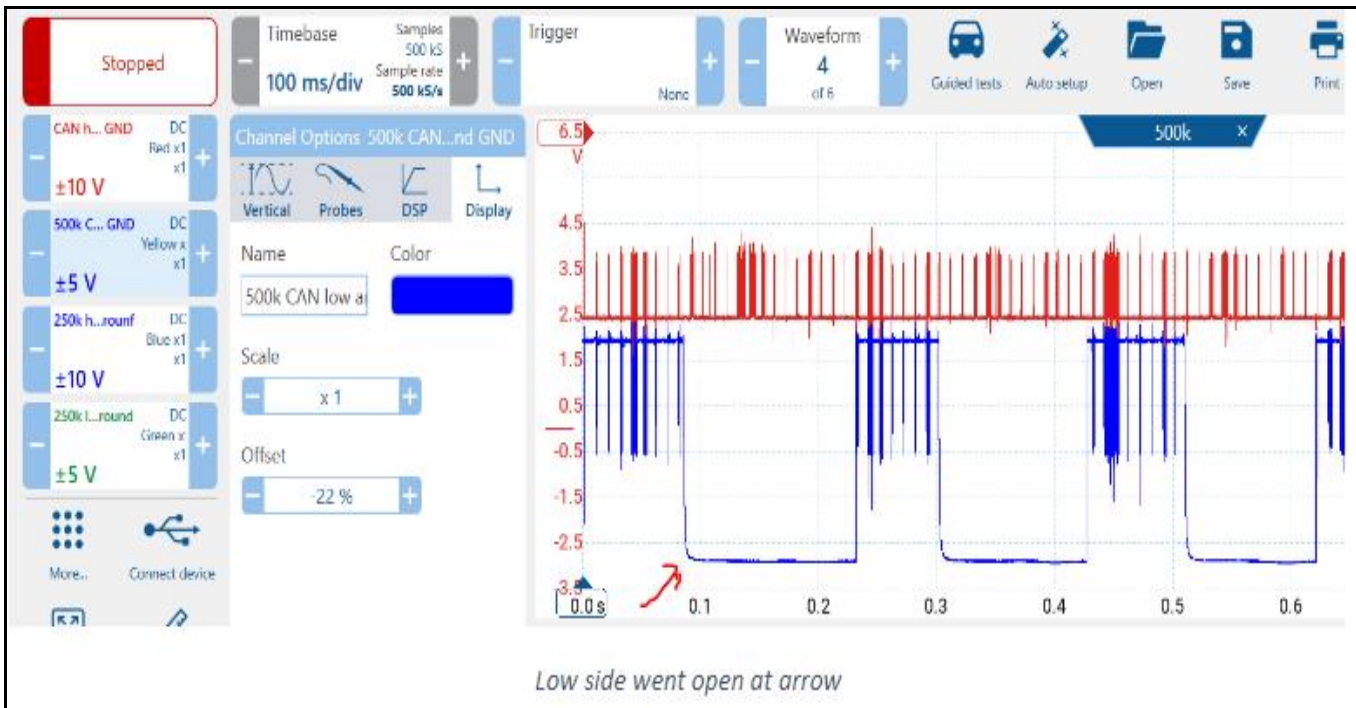

WARRANTY INFORMATION

Warranty Claim Coding:

Refer to the [Warranty Coding Manual](#) for Group and Noun Code

Standard Repair Time(s):

Refer to the [SRT Manual](#) for Repair Times if none are present refer to T-time policy.

OTHER RESOURCES

[Master Service Information Site](#)

Viewed: 59
Helpful: 2
Not Helpful: 1

No Feedback Found