

Air-Operated Clutch Assist Adjustment and Troubleshooting

M-413-004

(January 2009)

Valid for

All CXU, CHU, and GU with Air-Operated Clutch Assist

Case description

This service bulletin provides information concerning the air-operated clutch assist system, which is standard equipment on CXU, CHU, GU, CXP and CTP models. Included are exploded views, part numbers, adjustment procedures and a troubleshooting guide.

DESCRIPTION AND OPERATION

The air operated clutch assist system reduces clutch pedal effort approximately 20%, along with 50.8 mm (2") less pedal travel. The reduction in clutch pedal travel results in reduced initial pedal height, which provides more leg and knee room for the operator. This system increases operator comfort by reducing leg strain.

The air-operated clutch assist consists of a clutch cable with an integral pressure regulator and a single acting air cylinder. All components are made from corrosion resistant materials for added performance, durability and reliability.

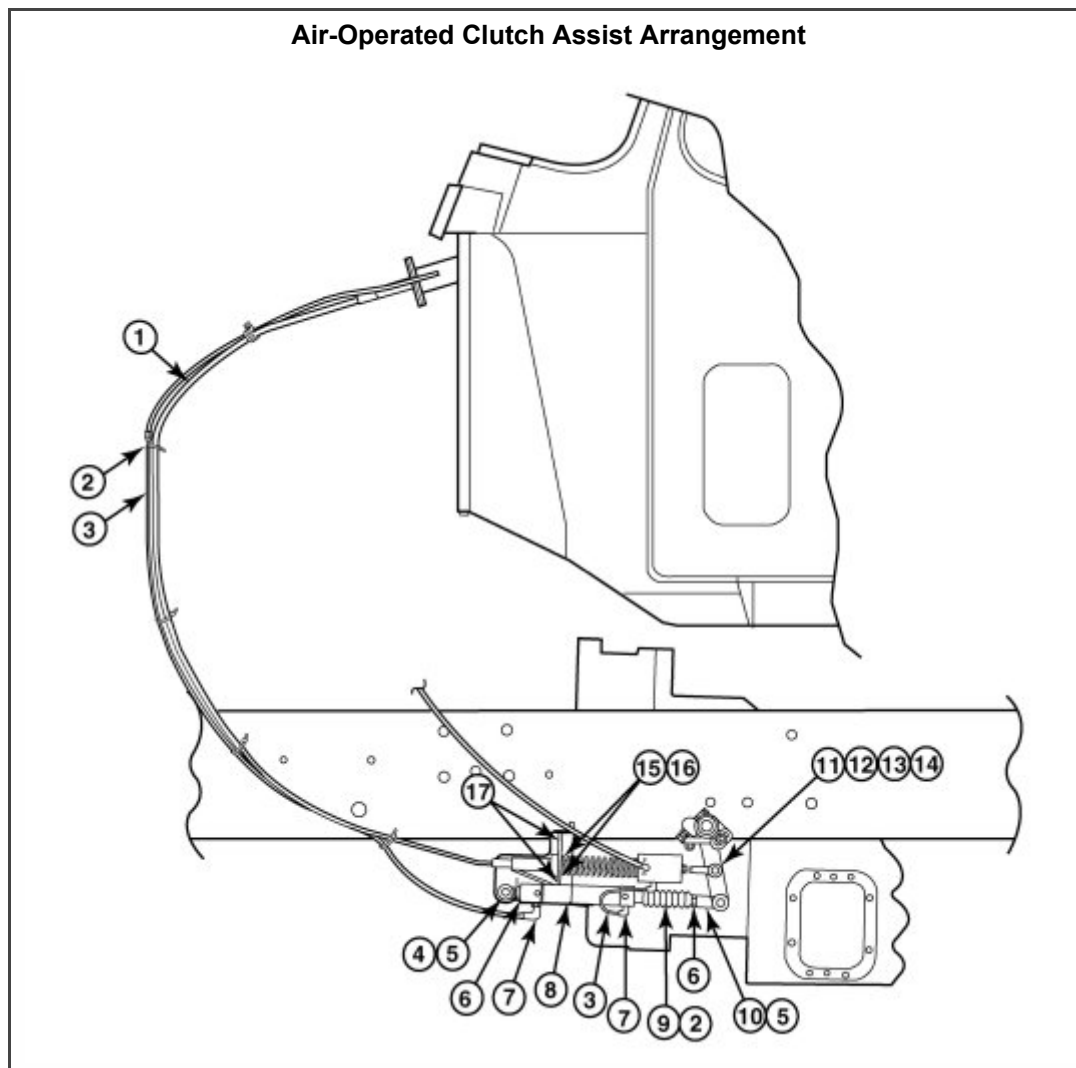

Item	Quantity	Part number	Description
1	1	20804977	Cable assembly, clutch, CXU, CXP, CHU, GU and CTP
2	6	48RU2313	Tie wraps
3	108"	101AX120RF	Tube, air line 1/4", total length 2743 mm (108"), 96.5 mm (38") for supply-to pressure regulator line, 20.3 mm (8") for pressure regulator-to-cylinder delivery line and 1 574.8 mm (62") for cylinder exhaust port-to-remote mounted cylinder
4	1	25171588	Threaded rod end, male
5	2	25090129	Lock nut, 7/16-20 UNF
6	1	25097874	Nut, 7/16-20 UNF
7	2	63AX54124	Fitting, 90-degree elbow, push-to-connect connector, 1/4" tube, external 1/8" NPTF
8	1	21131322	Cylinder, clutch assists
9	1	20956653	Boot, assist cylinder rod
10	1	25171587	Threaded rod end, female
11	1	35AX634	Spacer
12	1	1AX189	Bolt, 5/16-24 UNF-2A x 2-1/2" long
13	1	20704998	Flat washer 11/32" ID
14	1	20705513	Lock nut, 5/16-24 UNF
15	2	25094534	Pan head Torx® screw, M6 x 1.0 x 20 mm long
16	2	25161501	Lock nut (with nylon insert), M6 x 1.0
17	2	30AM12	Capscrew, flange-head, with patch lock, M12 x 1.75 x 30 mm long

Individual components for the clutch cable assemblies are available separately through the MACK Parts System. Part numbers are as follows:

Note: Effective September 17, 2007, a revised air-assist clutch cable (part number 27RC410M) was implemented into production on CXU, CHU and GU models. The revised cable includes a boot on the transmission end of the cable and an external return spring. This cable is a more robust design that is well suited for chassis that operate in severe conditions where the possibility of debris entering the transmission end of the cable exists. If clutch cable failure due to dirt intrusion is encountered on a chassis manufactured prior to September 17, 2007, replacement of the existing cable with the revised cable is recommended. Refer to service bulletin SB313004 for information concerning the revised air-assist clutch cable.

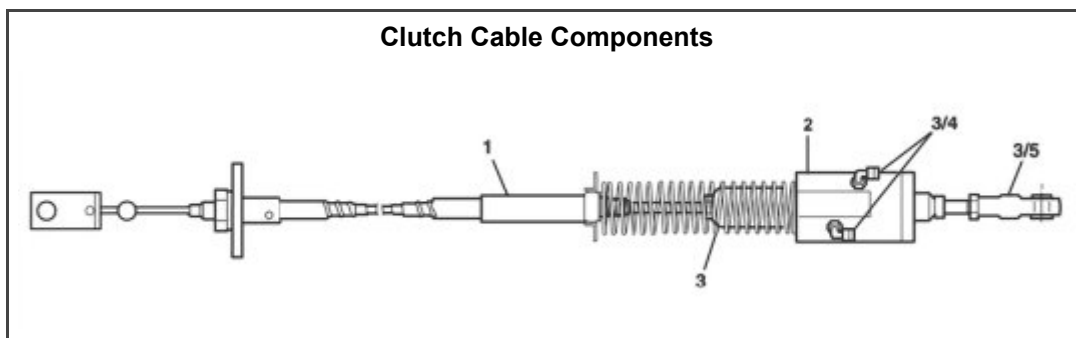

Cable Assembly part number	Item	Qty.	Part number	Description
27RC48M	1	1	2894-195300023	Replacement cable
	2	1	2894-190300239	Regulator
	3	1	2894-195300040	Kit, hardware (includes one threaded rod end, two 90 degrees push-to-

				connect air fittings, one spring and two nuts)
	4	2	21243492	Fitting
	5	1	85116896	Rod End

Air-Assist Clutch System Operation

Pressure for the clutch assist is supplied from the pressure protection valve located on the treadle valve. As the clutch pedal is pushed in to disengage the clutch, movement of the clutch cable opens the pressure regulator to allow air flow to the rod end of the cylinder. The amount of force placed on the clutch cable determines how much pressure is delivered by the regulator. As pressure enters the cylinder, the cylinder rod retracts and pulls the clutch release lever. The action of the assist cylinder pulling the release lever reduces the amount of pedal effort required to disengage the clutch.

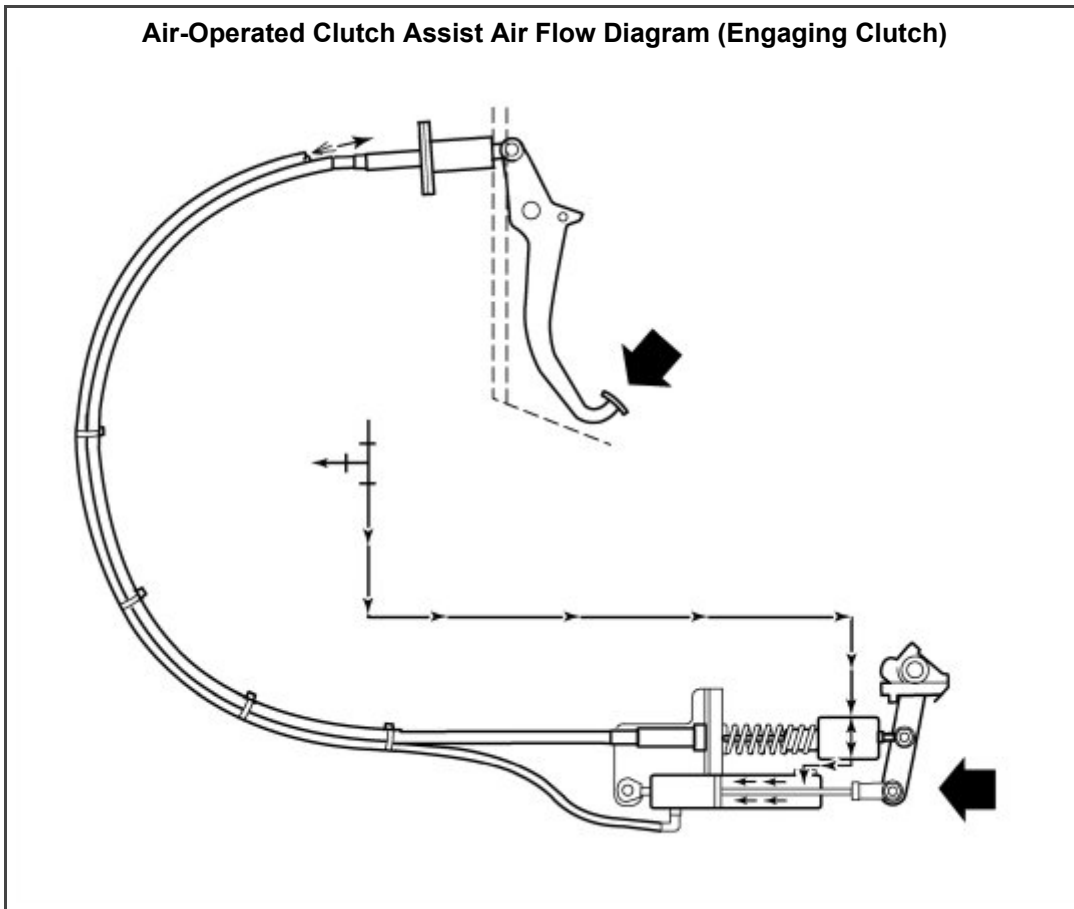

When the clutch pedal is released to engage the clutch, the pressure regulator closes and shuts off the flow of air to the cylinder. The return spring (integral with the clutch cable assembly) returns the release lever to its home position, and the returning release lever pulls the rod from the cylinder. As the rod extends, pressure inside the cylinder exhausts through an exhaust port in the regulator valve.

Air-Operated Clutch Assist Air Flow Diagram (Disengaging Clutch)

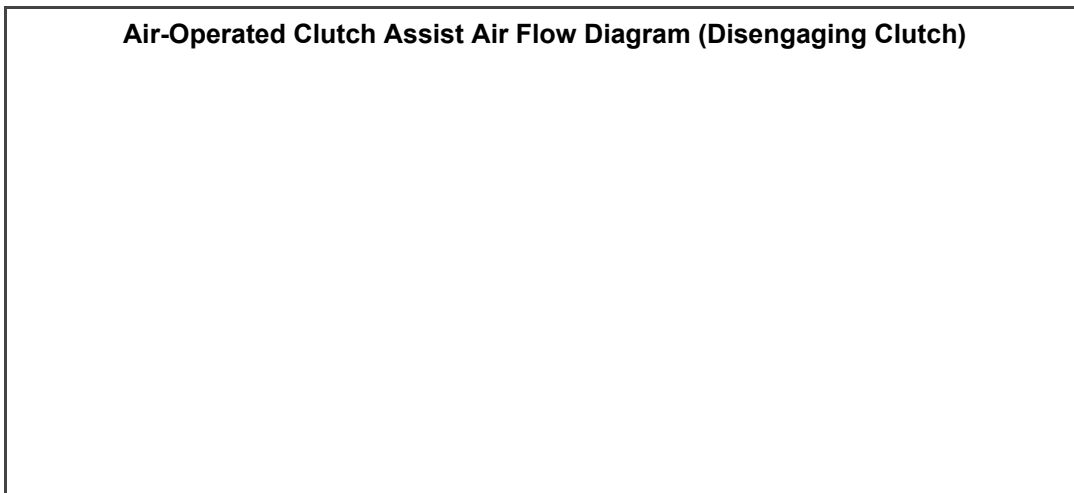

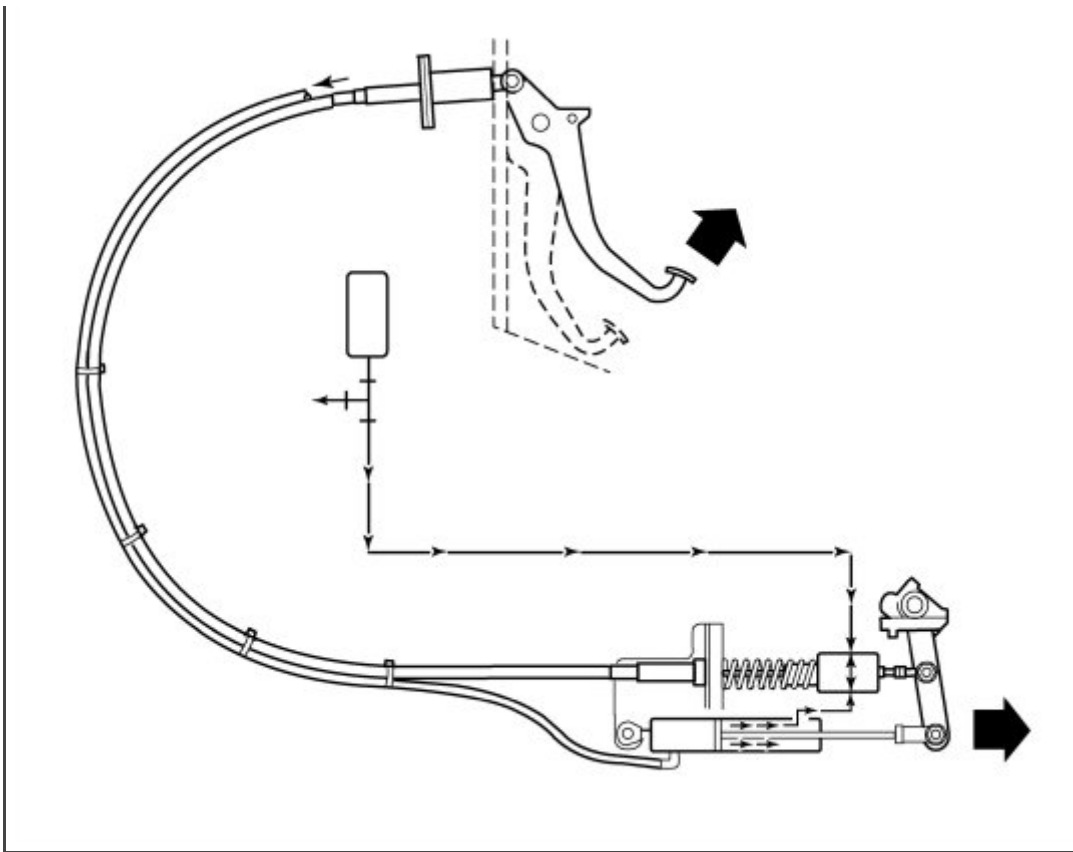

Clutch Release Cylinder Exhaust

As the clutch pedal is pushed in to disengage the clutch, the assist cylinder rod retracts into the cylinder. Air trapped in the “head-end” of the cylinder exhausts through the exhaust port at the rear of the cylinder. When the clutch pedal is released to engage the clutch, the cylinder rod extends. As the rod extends, air is drawn back into the cylinder through the exhaust port.

Note: To prevent debris from entering the cylinder, a sintered bronze filter is incorporated into the exhaust port. The filter is secured approximately mid-way up the clutch cable, and is connected to the cylinder exhaust port with a 1/4" plastic tube. With this arrangement, however, the possibility exists for moisture to be drawn into the cylinder, which can cause corrosion inside the cylinder and result in sticking or binding clutch operation. To prevent this from occurring, the vent line can be relocated to the clutch cable mounting tube located on the cab bulkhead. Refer to service bulletin SB313003 for information on relocating the cylinder vent.

CLUTCH ADJUSTMENT PROCEDURES

Verify Release Bearing Travel

In order for the clutch to release properly, the clutch release bearing must travel between 12.7–14.3 mm (1/2"–9/16"), and there must be 3.2 mm (1/8") of clearance between the clutch release yoke and the release bearing wear pads. The specified clearance between the clutch release yoke and the release bearing wear pads equates to 28.7 mm (1-1/8") of clutch pedal free travel in the cab.

With the clutch properly adjusted, clutch brake squeeze should occur within the last 6.35–9.53 mm (1/4"–3/8") of pedal travel.

Clutch travel or gap between the release bearing and clutch brake are adjusted by the internal clutch ring. Clutch brake/clutch pedal free travel is adjusted by varying the length of the external linkage.

Clutch adjustment procedures are as follows:



Before working on the vehicle, apply the parking brakes, place the transmission in neutral and block the wheels. Failure to do so can result in unexpected vehicle movement and can cause serious personal injury or death.

Note: You will need an assistant to hold the clutch pedal down (clutch released) to adjust release bearing free travel in all but the Sachs Twin Extend clutch.



Warning

Always wear appropriate eye protection to prevent the risk of eye injury. Keep your hand/fingers away from moving parts.

Verify and Adjust Clutch Brake Squeeze

Verify that clutch brake squeeze occurs within the last 6.35–9.53 mm (1/4"–3/8") of clutch pedal travel. Clutch brake squeeze is verified as follows:

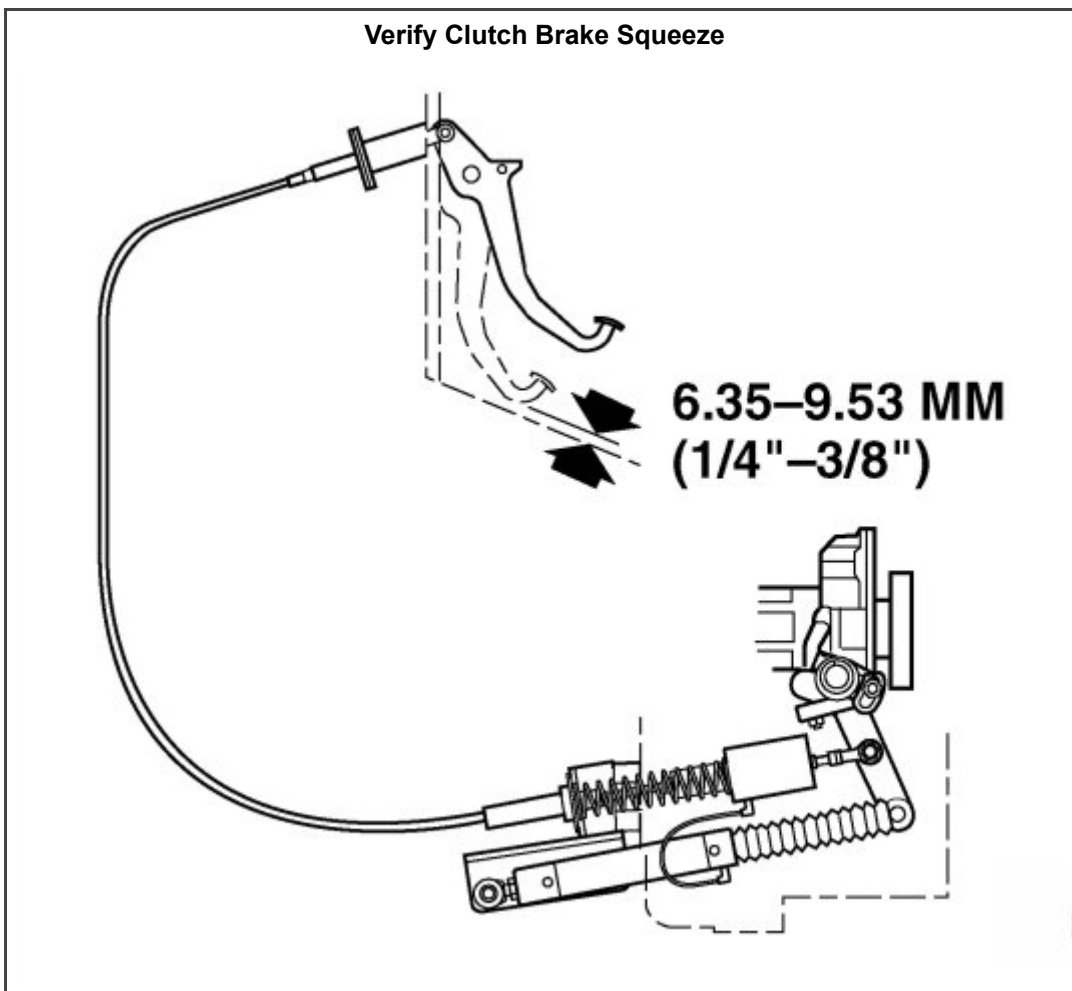

Warning

Use a gauge long enough to keep hands away from moving parts.

1. Remove the inspection cover from the transmission bell housing.

2. Insert a 0.254 mm (0.010") thickness gauge between the rear face of the clutch release bearing and the clutch brake.
3. Have an assistant fully depress the clutch pedal and then slowly release the pedal. Tell the assistant to stop releasing the pedal as soon as the thickness gauge can be pulled from between the release bearing and the clutch brake.
4. Measure the gap between the pedal and the pedal stop. If clutch brake squeeze does not occur within the last 6.35–9.53 mm (1/4"–3/8") of pedal travel, adjust as follows:

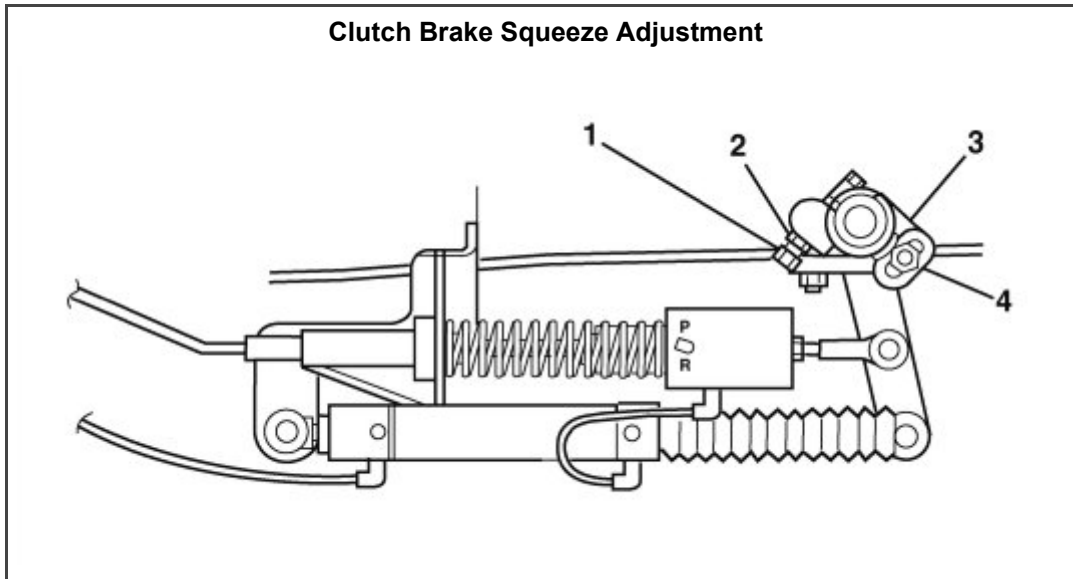

1. Adjusting Bolt	3. Clutch Dog
2. Jam Nut	4. Clutch Dog Lock Bolt

- a. Loosen the clutch dog lock bolt.
 - b. Loosen the adjusting bolt jam nut.
 - c. Turn the adjusting bolt to properly set clutch brake squeeze.
 - Turning the adjusting bolt clockwise results in clutch brake squeeze occurring further from the end of pedal travel (increases dimension).
 - Turning the adjusting bolt counterclockwise results in clutch brake squeeze occurring closer to the end of pedal travel (decreases dimension).
5. When clutch brake squeeze has been properly set, tighten the clutch dog bolt and the adjusting bolt jam nut.

Verify Clutch Pedal Free Play

After establishing the correct clutch brake squeeze, verify clutch pedal free play. Check for 3.2 mm (1/8") of clearance between the clutch release yoke and the release bearing wear pads. Pedal free travel for the cable-operated air-assist clutch release system should be 28.7 ± 6.4 mm (1-1/8" \pm 1/4"). There should be approximately 76.2–96.5 mm (3"–3.8") of cylinder rod visible when measured from the cylinder body to the bottom of the cylinder rod end. This dimension ensures that the cylinder will not bottom when the clutch pedal is pushed in (clutch disengaged). If the free play is inadequate investigate if the clutch cable, assist cylinder or mounting brackets are secured properly.



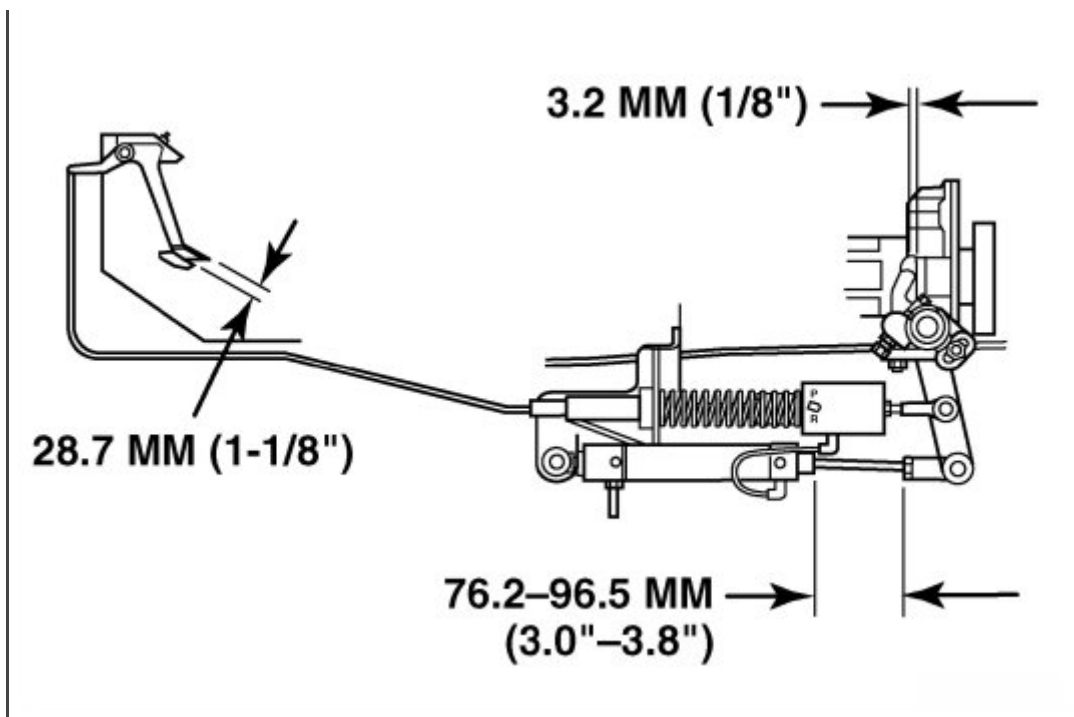

Adjustments for the different model clutches are as follows:

Eaton® Easy-Pedal™:

1. Using the appropriate engine turning tool, rotate the engine in the direction of normal rotation until the Kwik-Adjust™ component is visible through the bell housing inspection hole.
2. Have an assistant fully depress the clutch pedal (clutch released).
3. Insert a 5/8" socket or box wrench through the inspection hole and over the hex-head bolt on the Kwik-Adjust™ component.
4. While pedal is held down, push adjusting nut and turn:
 - a. If measurement was more that 14.2 mm (0.560") turn adjusting nut clockwise.
 - b. If measurement was less that 12.7 mm (0.500") turn adjusting nut counterclockwise.

Eaton ValueClutch™:

1. Using the appropriate engine turning tool, rotate the engine in the direction of normal rotation until the Lockstrap is visible through the bell housing inspection hole.
2. Have an assistant fully depress the clutch pedal (clutch released).
3. While pedal is held down, remove the lockstrap and move the adjusting lug:
 - a. If measurement was more that 14.2 mm (0.560") move the adjusting lug to the left.
 - b. If measurement was less that 12.7 mm (0.500") move the adjusting lug to the right.

Eaton Solo Clutch:

1. Initially adjust the linkage until the yoke fingers contact the release bearing (zero pedal free play).
2. Press the pedal to the floor up to 5 times, this:
 - o Moves the release bearing closer to the transmission.
 - o Gains free play in the cab.
3. With the pedal up, measure the distance between the release bearing and the clutch brake.
 - a. If the distance is more that 14.2 mm (0.560") return to step 1 and readjust the clutch linkage. (Adjust the linkage to establish the proper clutch brake squeeze.)

b. If the distance is less than 12.7 mm (0.500") the self-adjusting mechanism may need to be reset. Please refer to Eaton publication CLSM 0200 for further instructions.

Spicer Solo™ 15-1/2 Inch Self-Adjusting Clutch

Adjust the Spicer Solo™ 15-1/2" self-adjusting clutch by fully pressing and releasing the clutch pedal a minimum of five times. This "release bearing to clutch brake contact" ensures that the clutch is properly adjusted, and that release bearing travel is properly set to the specified 12.7–14.3 mm (1/2"–9/16").

Spicer Easy Pedal 15-1/2 Inch Angle Spring Clutches with Kwik-Adjust™ Component

1. Rotate the engine in the direction of normal rotation until the Kwik-Adjust™ component is visible through the bell housing inspection hole.
2. Insert a 5/8" socket or box wrench through the inspection hole and over the hex-head bolt on the Kwik-Adjust™ component.

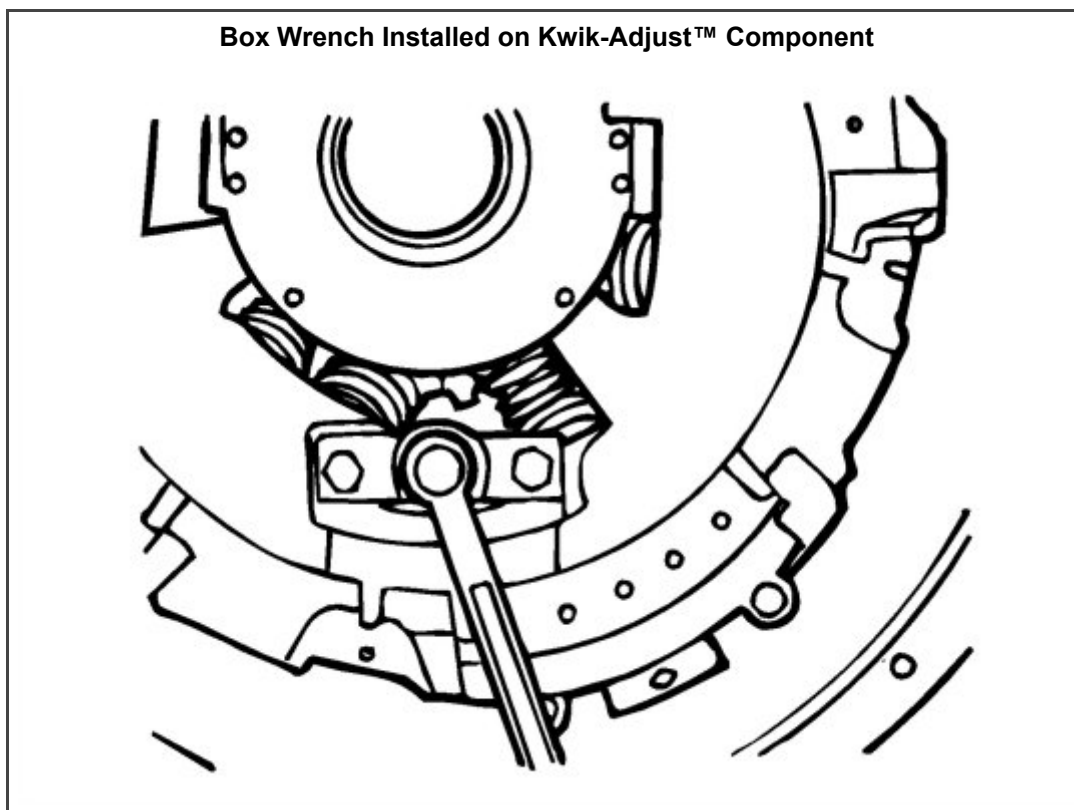

Note: On some clutches, the Kwik-Adjust™ component may utilize a square-head bolt which requires a 3/4" 12-point wrench or socket.

3. Have an assistant fully depress the clutch pedal (clutch released).
4. Depress and turn the Kwik-Adjust™ bolt in the direction of the arrow embossed on the clutch.

Note: The clutch must be released before attempting to turn the adjusting component.

Adjusting Clutch Ring



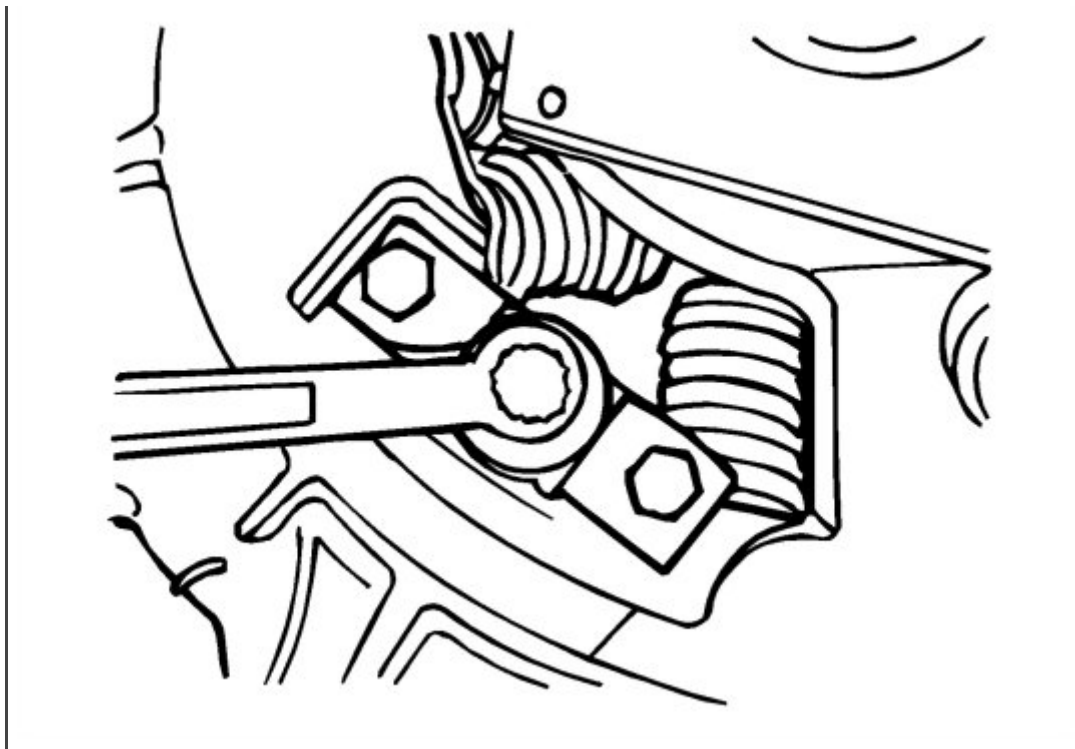

- Turning the Kwik-Adjust™ component clockwise moves the release bearing toward the transmission (increases clutch pedal free play).
- Turning the Kwik-Adjust™ component counterclockwise moves the release bearing toward the engine (decreases clutch pedal free play).

The Kwik-Adjust™ component will re-engage at each sixth turn, and a flat of the hex-head bolt will align with the flat on the edge of the bracket. Kwik-Adjust™ components that utilize the 3/4" square headed bolt will re-engage at every 1/4 turn.

5. Measure clutch pedal free play in the cab. If not within specifications, readjust the clutch ring as required.

ArvinMeritor™ 15-1/2 Inch Clutch

1. Rotate the engine in the direction of normal rotation until the clutch adjusting lock plate is visible through the bell housing inspection hole.

Clutch Adjustment Lock Plate

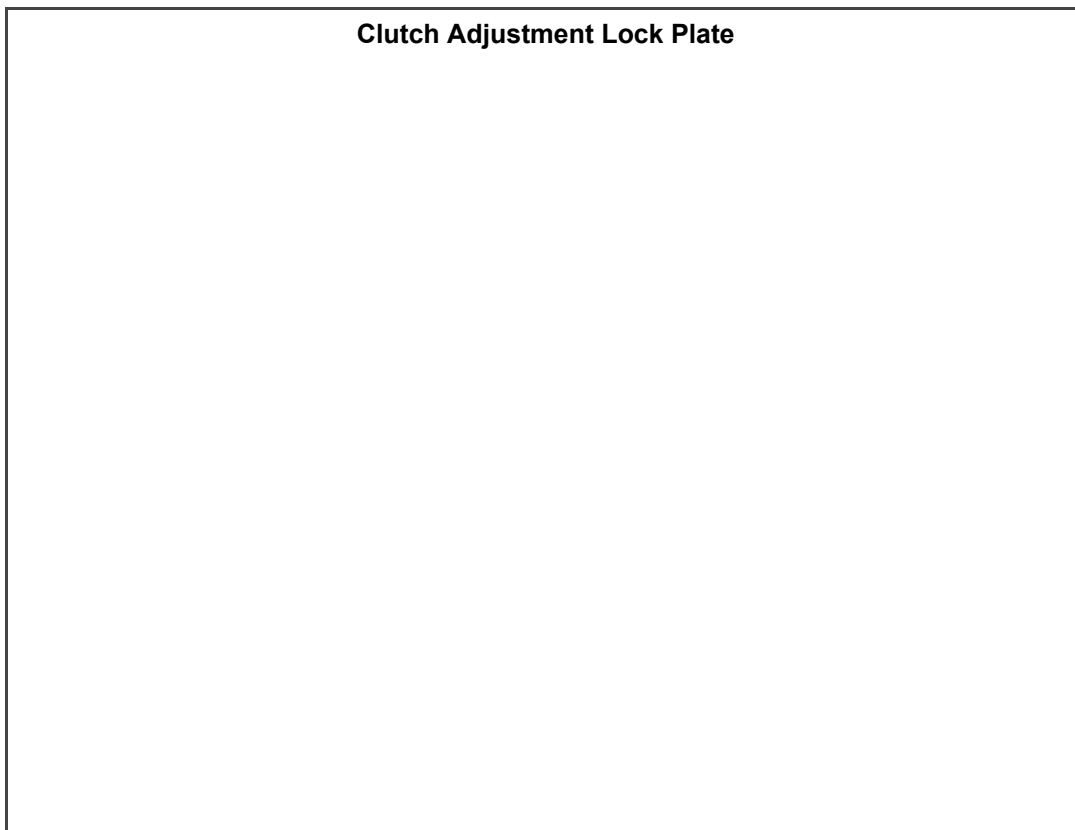

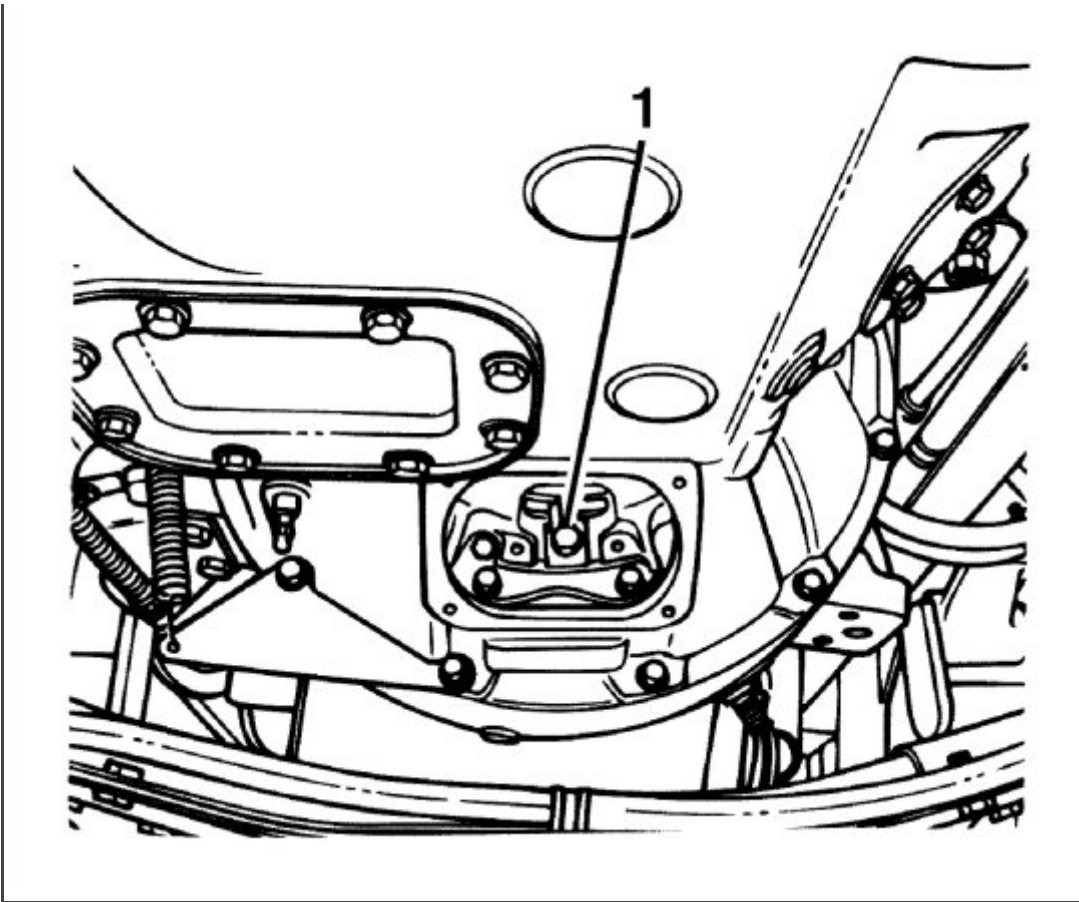

1. Lock Plate

- 2. Remove the screw and washer from the lock plate, and then remove the lock plate.
- 3. Have an assistant fully depress the clutch pedal (clutch released).
- 4. Using a universal clutch adjusting tool (tool No. J 36216) or a large screwdriver against the notches on the adjusting ring, turn the adjusting ring to move the release bearing as required to adjust clutch pedal free play. Moving the adjusting ring one notch moves the release bearing approximately 0.50 mm (0.020").

Note: The clutch must be released before attempting to turn the clutch adjusting ring.

Adjusting Clutch

TURN
ADJUSTING
RING
IN THIS
DIRECTION
TO MOVE
RELEASE
BEARING
TOWARD
CLUTCH.

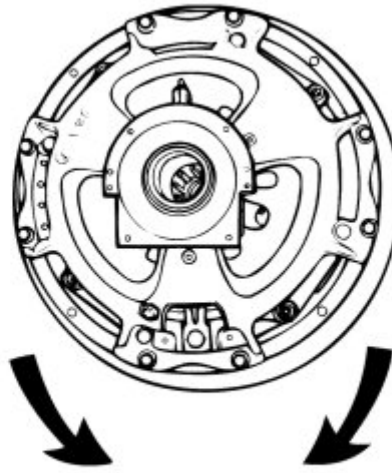

TURN
ADJUSTING
RING
IN THIS
DIRECTION
TO MOVE
RELEASE
BEARING
AWAY FROM
CLUTCH.

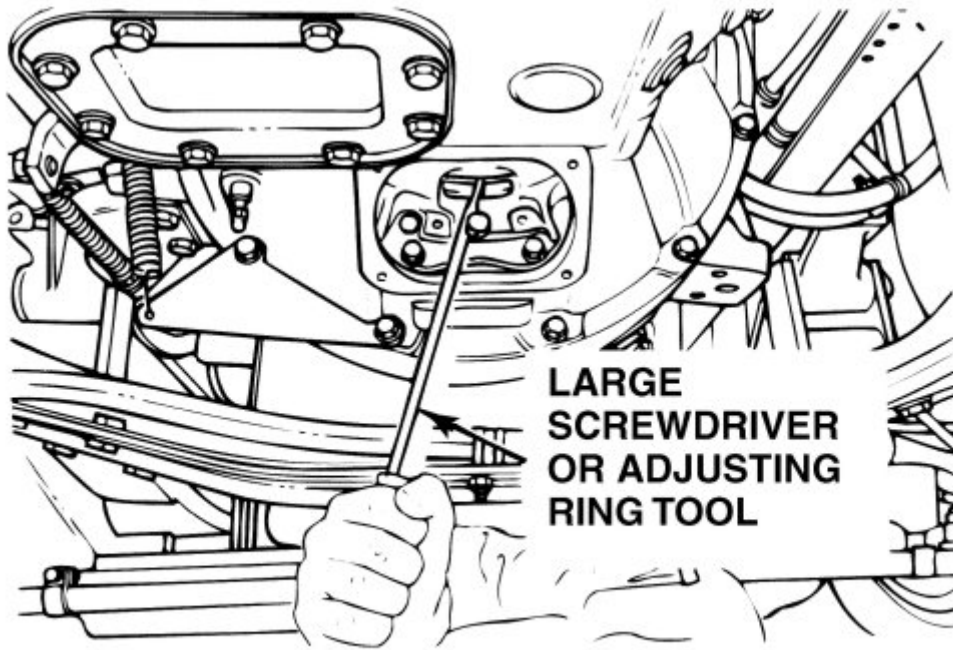

LARGE
SCREWDRIVER
OR ADJUSTING
RING TOOL

306245a

5. Once clutch pedal free play has been adjusted to proper specifications, reinstall the lock plate and tighten the capscrew to 37 N•m (27 lb-ft).
6. Refer to ArvinMeritor™ Clutches Maintenance Manual MM25A if further direction is required.

Sachs Twin XTend™ Clutch:

1. Hold lock nut number (1) with the 87 mm spanner. Refer to Figure 12 and Figure 13.

Note: Refer to Meritor publication TP0891 for the proper spanner wrench kit.

Twin XTend lock nut Adjustment

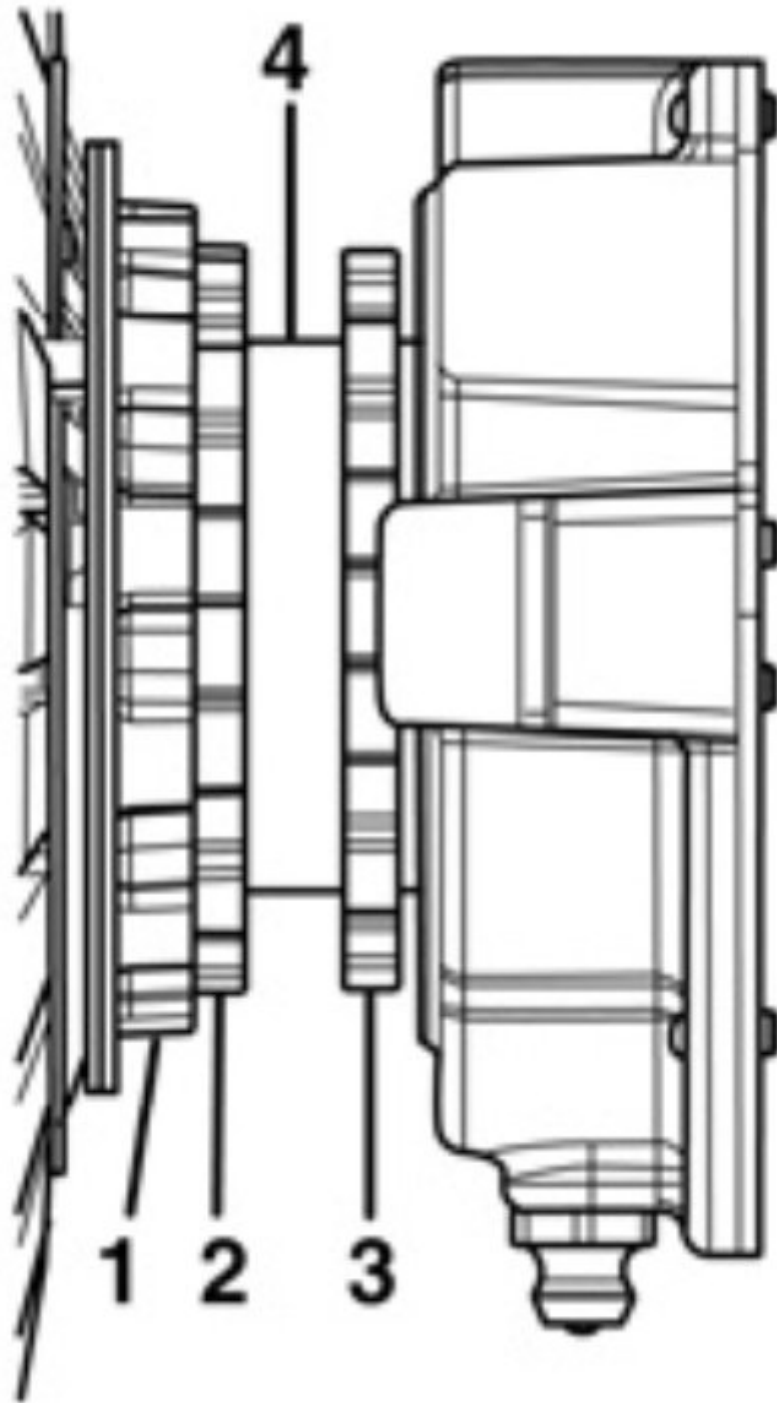

1. Lock nut No. 1

3. Lock nut No. 3

2. Lock nut No. 2

4. Threaded Sleeve

XTend Spanner Wrenches

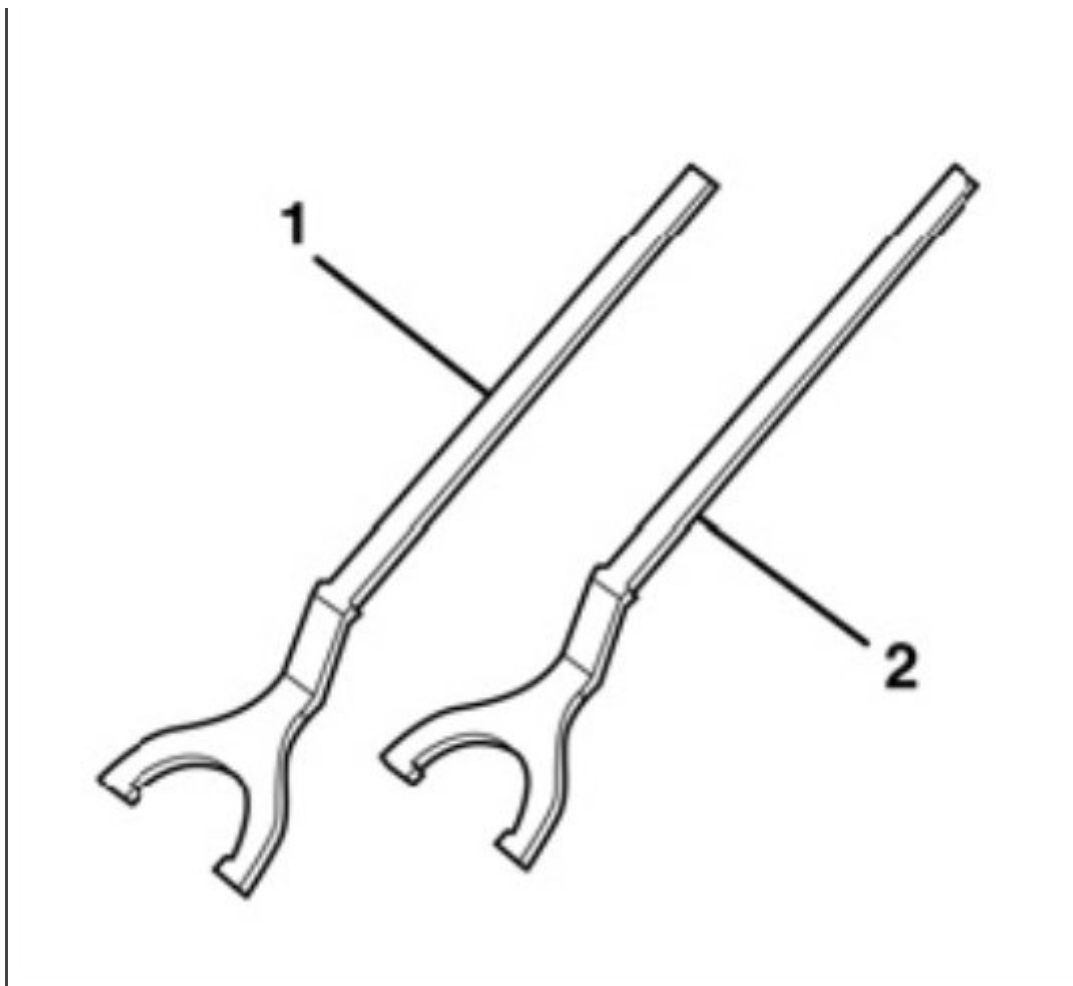

1. XTend Wrench 87, 87 mm

2. XTend Wrench 75, 75 mm

2. Rotate lock nut number (2) counterclockwise with the 75 mm spanner wrench to break the lock nuts free from each other. Refer to Figure.
3. Rotate lock nut number (3) counterclockwise to move the release bearing toward the clutch brake. Lock nut number (3) is fixed to the threaded collar. Refer to Figure.
4. Set the clutch brake-to-release bearing gap to achieve a clutch brake gap of 13.46 ± 0.76 mm (0.530 ± 0.030 inch).
5. Hold the lock nut number (1) with the 87 mm spanner wrench. Refer to Figure.
6. Rotate lock nut number (2) clockwise with the 75 mm spanner wrench to lock the lock nuts in place. Refer to Figure.

Verify Clutch Release Yoke and Release Bearing Travel

After clutch brake squeeze and clutch pedal free play have been properly adjusted, verify that 3.2 mm (1/8") of clearance exists between the clutch release yoke and the release bearing wear pads. Also verify that the release bearing travel is between 12.7 and 14.3 mm (1/2" and 9/16"). Release bearing travel is the distance between the rear face of the release bearing and the clutch brake. If not within specifications, recheck clutch brake squeeze and clutch pedal free play adjustments.

Verify Clutch Release Yoke Free Travel and Release Bearing Travel

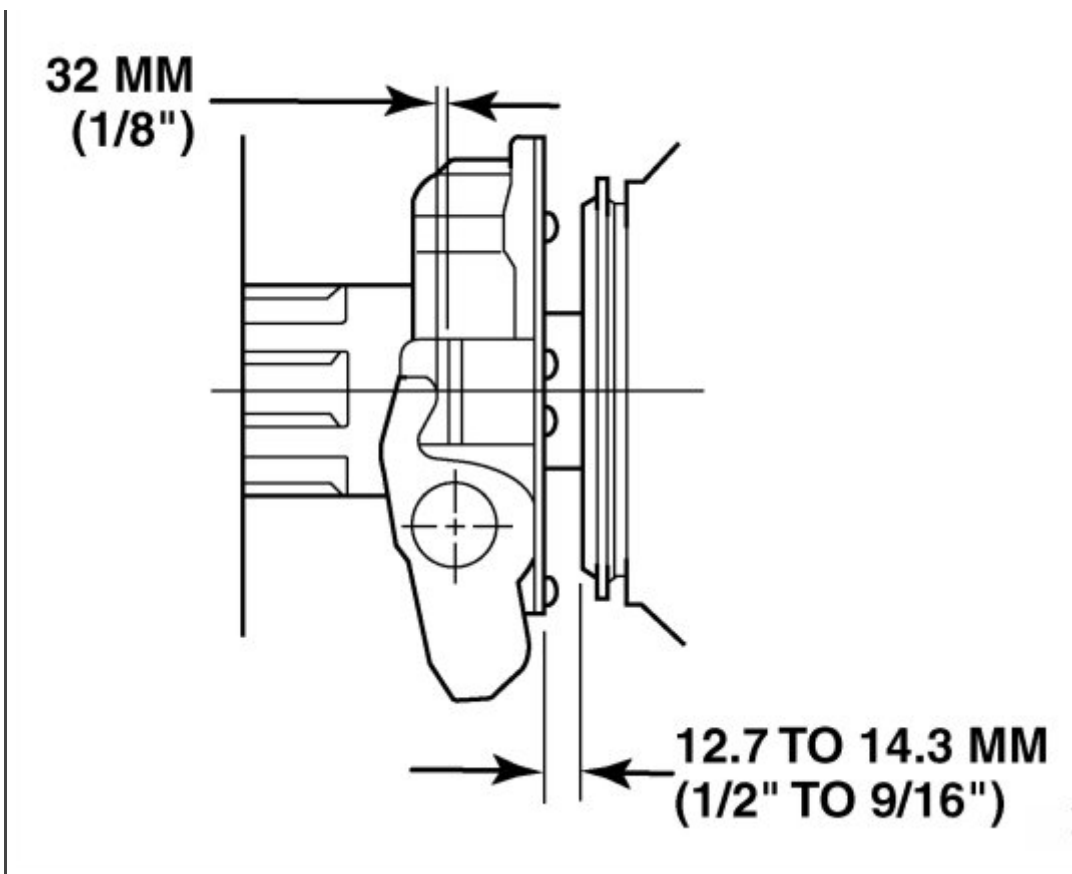

When satisfied that the clutch is properly adjusted, reinstall the cover over the transmission bell housing inspection hole.

TROUBLESHOOTING

The following troubleshooting chart summarizes the possible causes and corrective action for the two most common problems (increased pedal effort and failure of the pedal to fully return) that may be encountered with the air-operated clutch assist system.

Symptom	Possible Cause	Corrective Action
Increased Pedal Effort	1. Damaged or binding clutch pedal assembly, release lever shaft bearings and/or clevis pins.	1. Disconnect the clutch cable/regulator assembly and the cylinder from the clutch release lever, and then check the pedal assembly, release lever shaft bearings and the clevis pins for binding or damage. Replace components as required.
	2. Leaking assist cylinder due to worn cylinder rod and/or rod seal, or internal leakage due to damaged or worn piston seals.	2. Disconnect the vent line from the air cylinder exhaust port fitting. With the clutch pedal fully depressed, apply a soap and water solution around the cylinder rod seal and the cylinder exhaust port. There should be no evidence of leakage at either location. Replace the cylinder if leaking is evident.
	3. Air leakage in the clutch release circuit.	3. Apply a soap and water solution to the fittings at the pressure protection valve, regulator valve and assist cylinder inlet port. Replace any fittings found to be leaking or defective. When checking for leakage at the assist cylinder inlet port, depress and release the clutch pedal. <i>Note: NOTE: Use only OEM fittings on the air regulator.</i>
	4. Binding assist cylinder.	4. Check the assist cylinder for damage by disconnecting the cylinder from the release lever and disconnect the air lines from the cylinder. Move the rod through a full stroke several times and ensure that the rod moves freely through its full-length of travel. Inspect the body of the cylinder for dents and the piston rod for

		evidence of water or debris contamination. Replace the cylinder if any damage is found, or if there are dents on the body of the cylinder.
	5. Clogged cylinder vent line or fittings.	5. Relocate the cylinder vent line to the clutch cable mounting tube located on the cab bulkhead. Refer to service bulletin SB313003 for information on relocating the vent line.
Increased Pedal Effort (continued)	6. Defective clutch cable.	6. Check the clutch cable by disconnecting the cable from the clutch pedal and the clutch release lever, and then checking the inner cable for freedom of movement. The inner cable must move freely inside the cable housing. Replace the cable if it is kinked, frozen, worn, contaminated or otherwise damaged. DO NOT lubricate the cable.
	7. Low chassis air system pressure. The clutch release system requires a minimum of 621 kPa (90 psi).	7. Check system pressure at the regulator supply port. If system pressure at the regulator is below 621 kPa (90 psi), determine the cause and repair as necessary.
	8. Defective regulator.	8. Install a T-fitting and an accurate air pressure gauge in the delivery line at the regulator. Depress the clutch pedal fully to the floor, far enough to compress the clutch brake. Delivery pressure at the regulator should be close to supply pressure. If no delivery pressure is seen, replace the regulator.
Clutch Pedal Does Not Return to Fully Released Position	1. Broken return springs.	1. Inspect both the clutch pedal return spring and the clutch cable return spring at the regulator valve. Replace any broken springs.
	2. Regulator leaking air when clutch is released.	2. Check clutch cable adjustment and adjust if not within specifications. Check for delivery pressure coming from the regulator with the clutch pedal released. If pressure is seen, replace the clutch cable/regulator assembly.
	3. Same possible causes as listed above for "Increased Pedal Effort."	3. Check items 1 through 8 above and repair, adjust or replace components as required.

Issued by

Technical Service

Mack Trucks, Inc. engages in a continuous program of testing and evaluating to provide the best possible product. Mack Trucks, Inc., however, is not committed to, or liable for updating existing chassis.