



# Technical Service Bulletin

---

## 66 Wheel arch trim on front fender loose

66 22 91 2067881/1 August 30, 2022.

Model(s)	Year	VIN Range	Vehicle-Specific Equipment
Q3	2019 - 2023	All	Not Applicable

## Condition

### Customer states:

A visible gap between the front wheel arch trim and the front fender is visible.

### Workshop findings:

The front wheel arch molding clips are not fully seated to the fender surface.

## Technical Background



# Technical Service Bulletin

---

During the trim installation process in production the female grommet that retains the male clip on the trim engages the male clip before it is fully seated to the fender surface creating a visible gap between the front wheel arch molding and the fender surface (Figures 1 & 2).



*Figure 1. The front wheel arch trim is not flush to the fender surface.*



*Figure 2. The front wheel arch trim with the retaining clips only partially engaged.*



# Technical Service Bulletin

---

When the front wheel arch trim is removed damage to the female clip grommet is apparent (Figure 3).

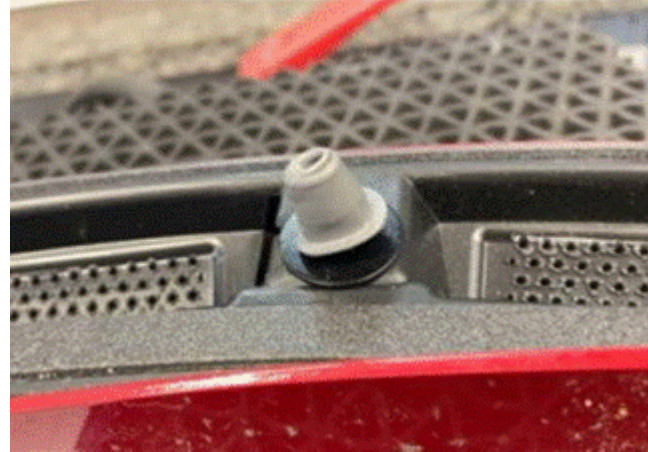

*Figure 3. Front wheel arch trim with retaining clip grommet damaged.*

## Production Solution

The process for the installation of the front wheel arch molding has been refined in production.

## Service



# Technical Service Bulletin

1. Using the T10383 wedge set remove the front wheel arch trim (Figure 4).

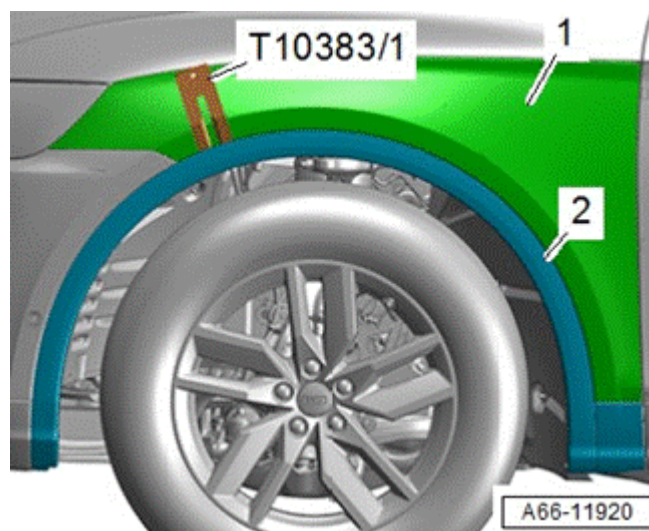

Figure 4. Front wheel arch trim removal.

2. Replace all of the clips on the affected front wheel arch trim. The wheel arch trim does not need to be replaced (Figure 5).

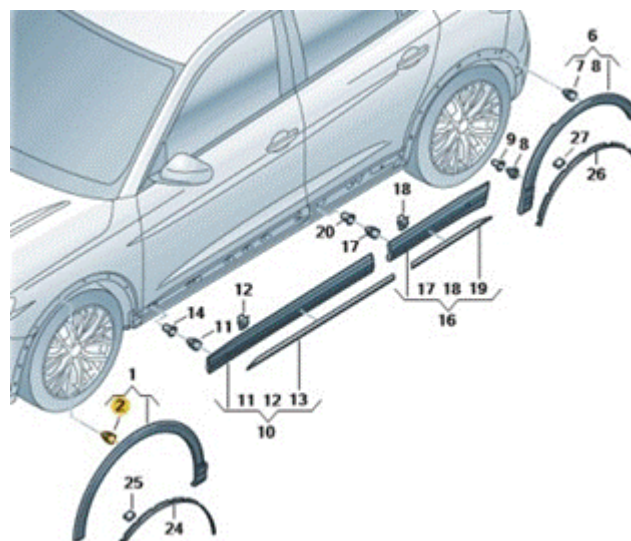

Figure 5. Front wheel arch trim clip location.



# Technical Service Bulletin

---

## Warranty

<b>Claim Type:</b>	<ul style="list-style-type: none"><li>• 110 up to 48 Months/50,000 Miles.</li><li>• If the vehicle is outside of any warranty, this Technical Service Bulletin is informational only.</li></ul>		
<b>Service Number:</b>	6619		
<b>Damage Code:</b>	0018		
<b>Labor Operations:</b>	Front wheel arch molding remove and reinstall.	6619 1900	See SRT with associated operations
	-or-		
	Both front wheel arch moldings remove and reinstall.	6619 2000	See SRT with associated operations
<b>Diagnostic Time:</b>	GFF	No allowance	0 TU
	Road test prior to the service procedure	No allowance	0 TU
	Road test after the service procedure	No allowance	0 TU
<b>Claim Comment:</b>	As per TSB 2067881/1		

All warranty claims submitted for payment must be in accordance with the *Audi Warranty Policies and Procedures Manual*. Claims are subject to review or audit by Audi Warranty.

## Required Parts and Tools

---



# Technical Service Bulletin

Always check with your Parts Department and/or ETKA for the latest information and parts bulletins.

Part Number	Part Description	Quantity
5J0 853 573	 Clip	9 per wheel arch molding
D 009 401 04	 All Purpose Cleaner	0.1



# Technical Service Bulletin

---

Tool Number	Tool Description
T10383	 <p data-bbox="516 982 654 1020">Wedge Set</p>

## Additional Information

All parts and service references provided in this TSB (2067881) are subject to change and/or removal. ©2022 Audi of America, Inc. All rights reserved. The information contained in this document is based on the latest information available at the time of printing and is subject to the copyright and other intellectual property rights of Audi of America, Inc., its affiliated companies, and its licensors. All rights are reserved to make changes at any time without notice. No part of this document may be reproduced, stored in a retrieval system, or transmitted in any form or by any means, electronic, mechanical, photocopying, recording, or otherwise, nor may these materials be modified or reposted to other sites, without the prior expressed written permission of the publisher.