



# VOLUNTARY SERVICE CAMPAIGN

Classification: RS22-003B	Reference: NTB22-063B	Date: August 8, 2022
------------------------------	--------------------------	-------------------------

## VOLUNTARY SERVICE CAMPAIGN 2021 ROGUE; PASSENGER SIDE SEAT BELT RETRACTOR AND AIRBAG MODULE

This bulletin has been amended. See AMENDMENT HISTORY on the last page.  
Please discard previous versions of this bulletin.

**CAMPAIGN ID #:** P2A08  
**APPLIED VEHICLES:** 2021 Rogue (T33)

**Check Service COMM or Dealer Business Systems (DBS)  
National Service History to confirm campaign eligibility.**

### INTRODUCTION

Nissan is conducting this voluntary service campaign, on certain specific model year 2021 Rogue vehicles, to update the front passenger (RH) side seat belt retractor assembly and airbag module, and reprogram the airbag diagnosis sensor unit. Vehicles with this update applied were tested by NHTSA in March 2021 and received an overall safety rating of 4 stars and a front passenger safety rating of 4 stars. This is not a safety recall as all Rogue vehicles meet all U.S. Federal Motor Vehicle Safety Standards. This service will be performed at no charge to the customer for parts or labor.

### IDENTIFICATION NUMBER

Nissan has assigned identification number P2A08 to this campaign. This number must appear on all communication and documentation of any nature dealing with this campaign.

### DEALER RESPONSIBILITY

Dealers are to repair vehicles falling within range of this campaign that enter the service department. This includes vehicles purchased from private parties, vehicles presented by transient (tourists) owners, and vehicles in a dealer's inventory.

Nissan Bulletins are intended for use by qualified technicians, not 'do-it-yourselfers'. Qualified technicians are properly trained individuals who have the equipment, tools, safety instruction, and know-how to do a job properly and safely. **NOTE:** If you believe that a described condition may apply to a particular vehicle, DO NOT assume that it does. See your Nissan dealer to determine if this applies to your vehicle.

## REPAIR OVERVIEW

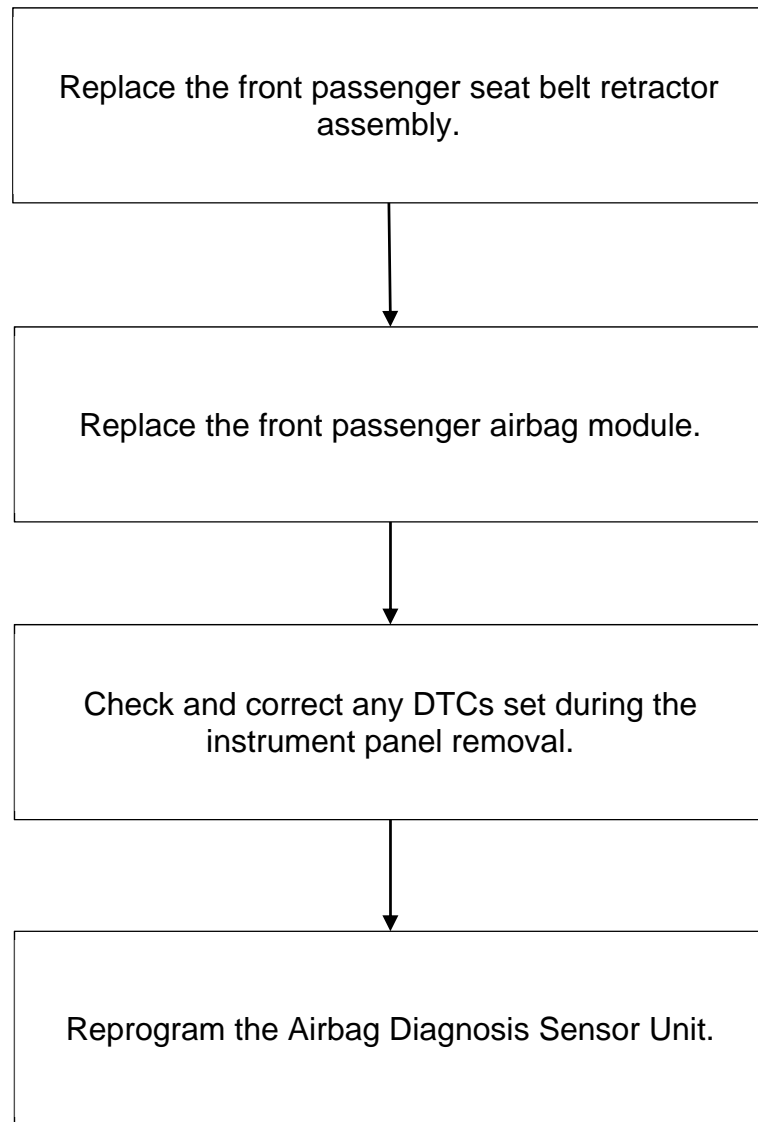

## SERVICE PROCEDURE

### Front Passenger Seat Belt Retractor Assembly Replacement

1. Open the front and rear passenger (RH) side doors, and then slide the front passenger seat to the forward-most position, as shown in Figure 1.



Figure 1

2. Open the hood and disconnect the negative battery terminal.
  - Verify the ignition is OFF before disconnecting the terminal.
  - Install protective tape over the negative battery terminal.
  - Wait a minimum of 3 minutes before proceeding, so that the air bag diagnosis unit may fully discharge any remaining electricity.

#### **NOTICE**

To prevent damage to the ACC power supply, do not operate the vehicle, such as locking/unlocking or opening/closing the doors within the 3 minute waiting period.



Figure 2

**⚠ WARNING**

To prevent the risk of personal injury or damage to the vehicle, verify the ignition switch is OFF and a minimum of 3 minutes has elapsed since the negative battery terminal was disconnected, before proceeding to step 3.

**NOTICE**

To prevent damage to the interior trim pieces, always use a trim removal tool made from plastic.

3. Remove the passenger side front kicking plate.
  - Disengage the thirteen (13) front kicking plate fixing pawls, as indicated by the arrows shown in Figure 3.

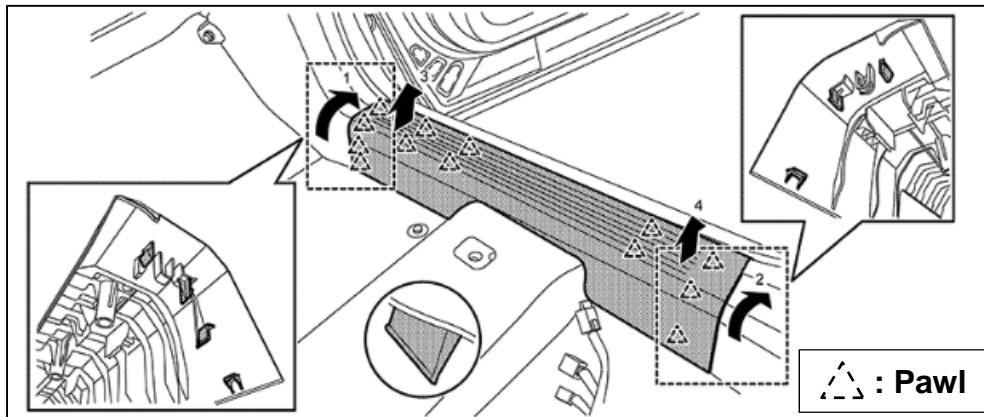

Figure 3

4. Remove the passenger side rear kicking plate.
  - Disengage the six (6) rear kicking plate fixing pawls and two (2) clips, as indicated by the arrows shown in Figure 4.

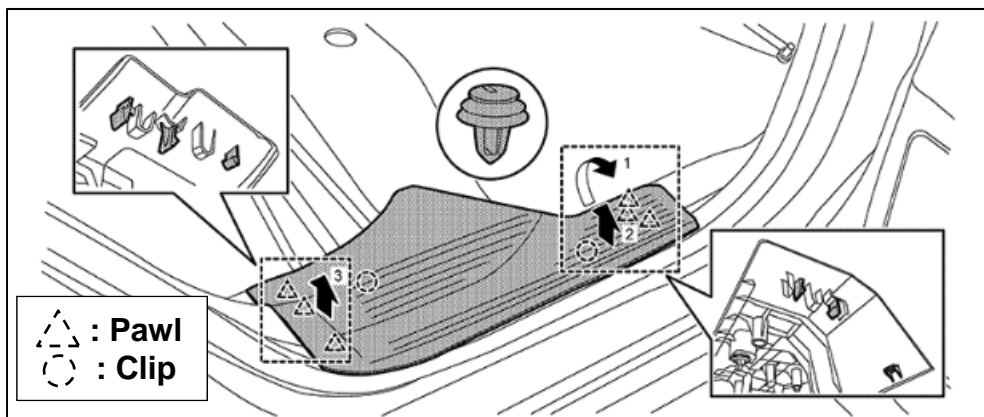

Figure 4

5. Disengage the two (2) seat belt cover fixing pawls, and then remove the seat belt cover.

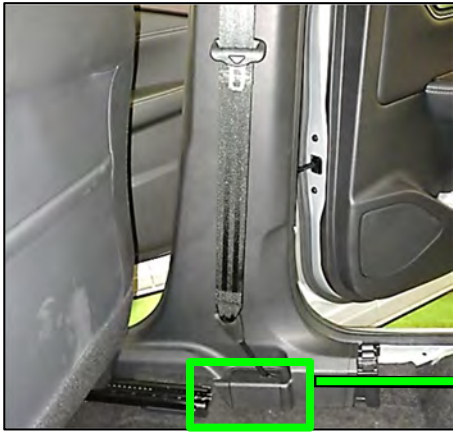

Figure 5

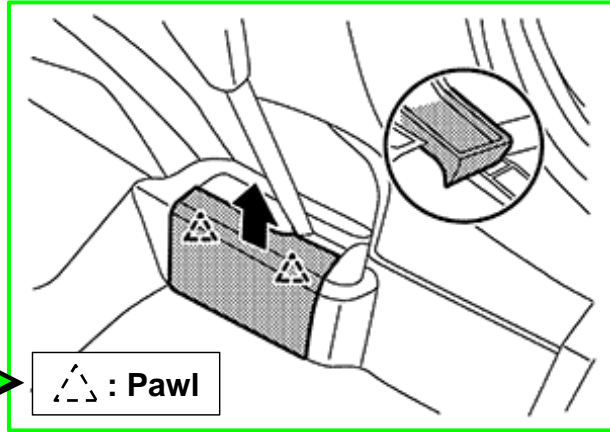

Figure 6

6. Remove the front and rear body side welt.

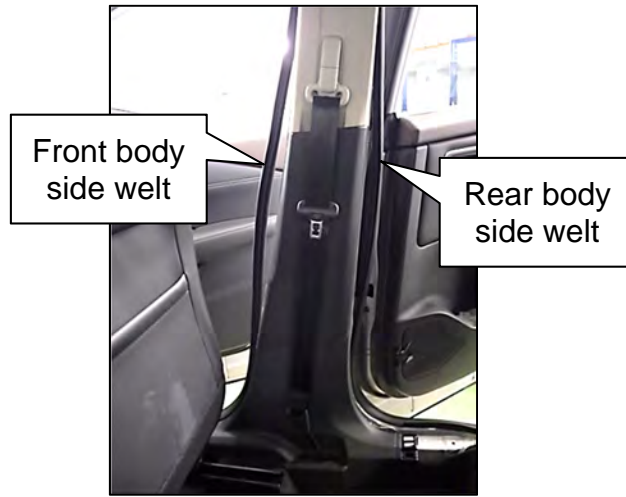

Figure 7

7. Disengage the two (2) center pillar lower garnish upper fixing pawls.



Figure 8

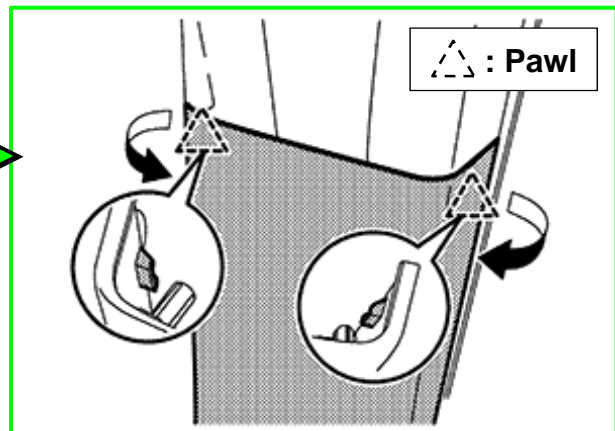

Figure 9

8. Disengage the three (3) center pillar lower garnish fixing clips, and then remove the center pillar lower garnish.

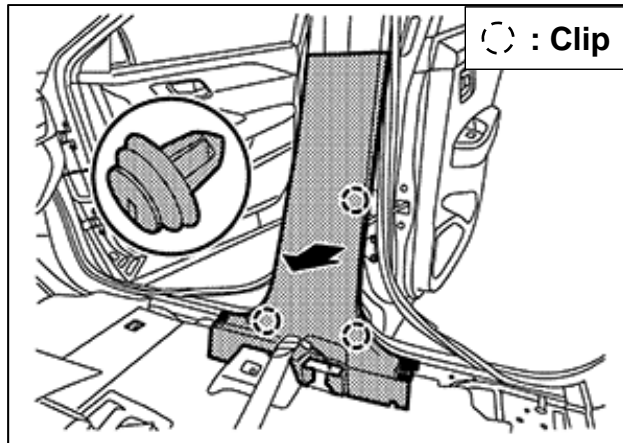

Figure 10



Figure 11

9. Disconnect the lap belt pre-tensioner and seat belt retractor wire harness connectors (Figure 12).

**HINT:** For removing the wire harness connectors:

- a. Insert a thin flat blade screwdriver, wrapped in tape, into the notch.
- b. Lift the lock.
- c. Remove the wire harness connector.

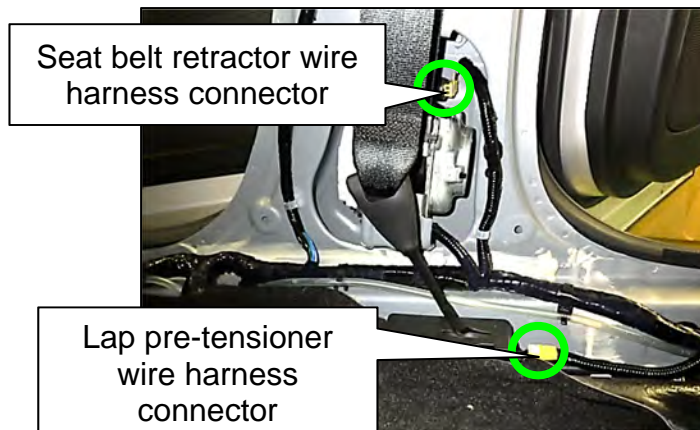

Figure 12

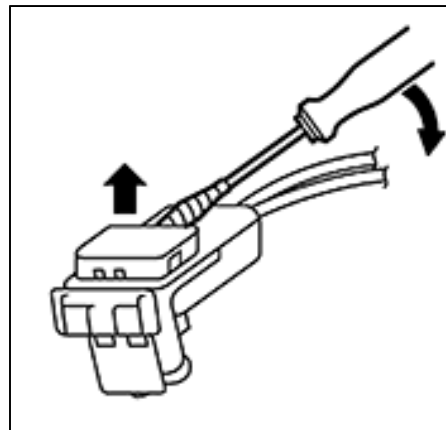

Figure 13

10. Remove the lap belt pre-tensioner mounting bolt, and then remove the lap pre-tensioner assembly.

**HINT:** Fold the carpet back to access the lap pre-tensioner mounting bolt.

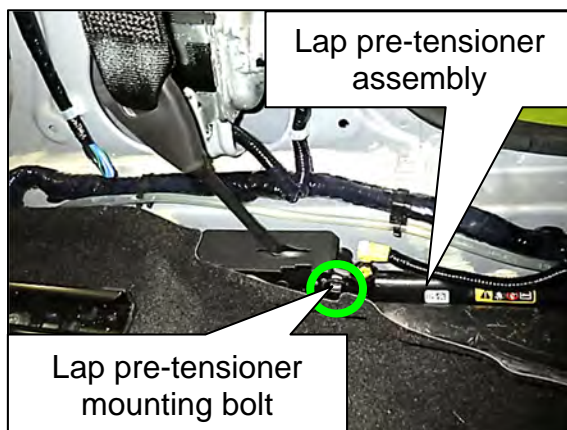

Figure 14

11. Remove the seat belt retractor mounting bolt.

**NOTE:** Do not remove the seat belt retractor assembly. It will be removed at step 14 on page 9.

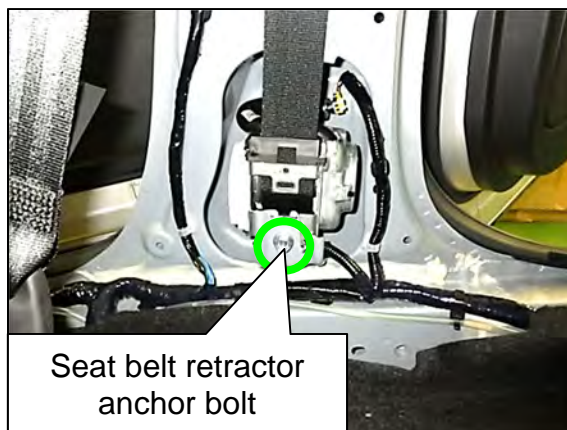

Figure 15

- 12. Remove the shoulder belt adjuster cover.
  - a. Pull out on the shoulder belt adjuster cover's lower side, and then disengage the adjuster cover lower side fixing pawls.



Figure 16

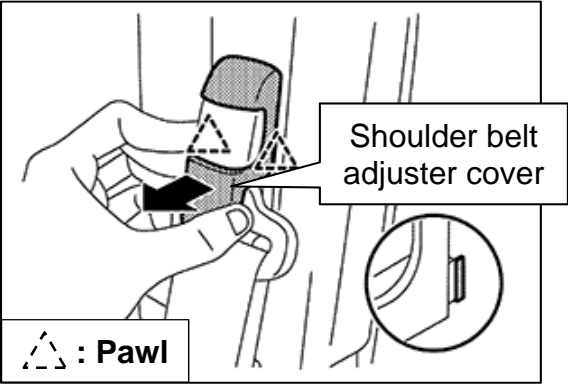

Figure 17

- b. Apply protective tape on the B-pillar trim next to the shoulder belt adjuster cover, as shown in Figure 18.

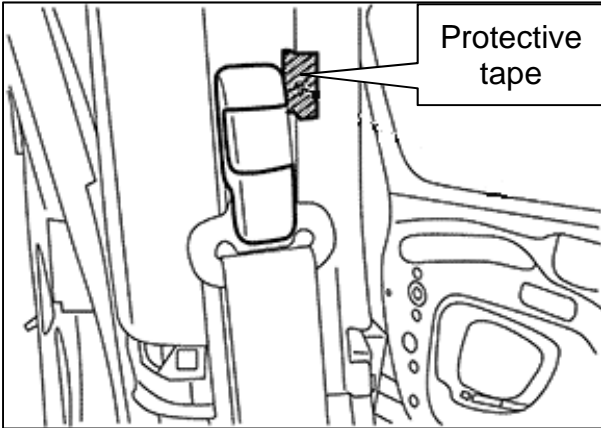

Figure 18

- c. Using a remover tool, disengage the one (1) shoulder belt adjuster cover fixing pawl, as indicated by the arrow shown in Figure 19, and then remove the adjuster cover.

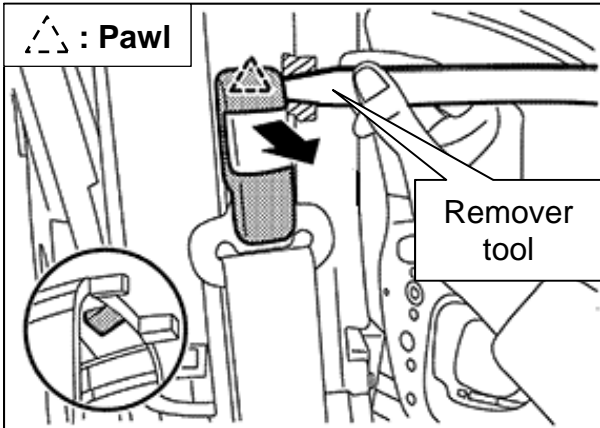

Figure 19



13. Remove the shoulder belt anchor mounting bolt, and then remove the shoulder belt anchor.

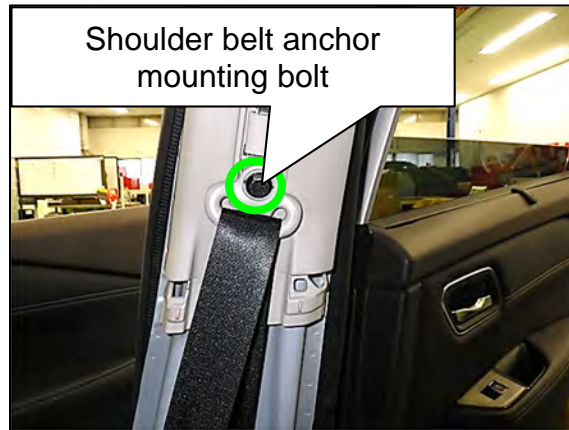

Figure 20

14. Remove the seat belt retractor assembly from the vehicle.

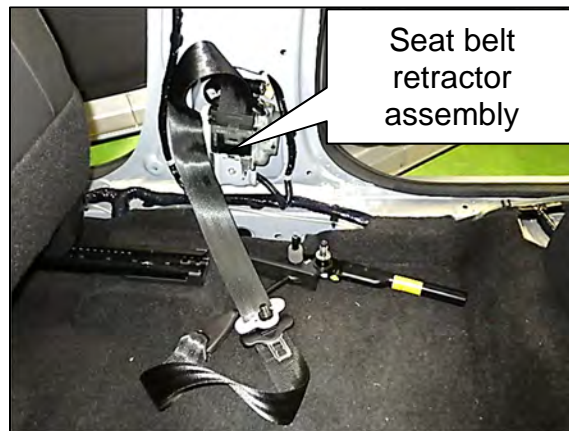

Figure 21

15. Install the new seat belt retractor assembly from **PARTS INFORMATION** in the reverse order of removal.
  - Shoulder belt anchor mounting bolt torque: 49 N•m (5.0 kg-m, **36 ft-lb**)
  - Seat belt retractor mounting bolt torque: 49 N•m (5.0 kg-m, **36 ft-lb**)
  - Lap belt pre-tensioner mounting bolt torque: 49 N•m (5.0 kg-m, **36 ft-lb**)
16. Verify that all seat belt retractor wire harness connector locks are fully seated.
17. Verify seat belt retractor operation.

18. Remove the protective tape from the negative battery terminal, and then install the negative cable to the battery terminal.
  - Negative battery cable terminal nut torque: 5.4 N•m (0.6 kg-m, **48 in-lb**)

### Front Passenger Airbag Module Replacement

19. Open both front doors, and then slide both front seats to the rear most position, as shown in Figure 22 and Figure 23.



Figure 22



Figure 23

20. Open the hood and disconnect the negative battery terminal.
  - Verify the ignition is OFF before disconnecting the terminal.
  - Install protective tape over the negative battery terminal.
  - Wait a minimum of 3 minutes before proceeding so that the air bag diagnosis unit may fully discharge any remaining electricity.

#### **NOTICE**

To prevent damage to the ACC power supply, do not operate the vehicle, such as locking/unlocking or opening/closing the doors within the 3 minute waiting period.



Figure 24

**⚠ WARNING**

To prevent the risk of personal injury or damage to the vehicle, verify the ignition switch is OFF and a minimum of 3 minutes has elapsed since the negative battery terminal was disconnected, before proceeding to step 21.

**NOTICE**

To prevent damage to the interior trim pieces, always use a trim removal tool made from plastic.

21. Disengage the one (1) center console fixing clip and the seven (7) metal clips, as indicated by the arrows shown in Figure 26 and Figure 28, and then remove the driver (LH) side and the passenger (RH) side instrument side panel.

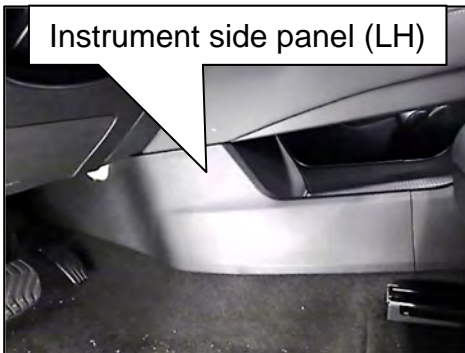

Figure 25

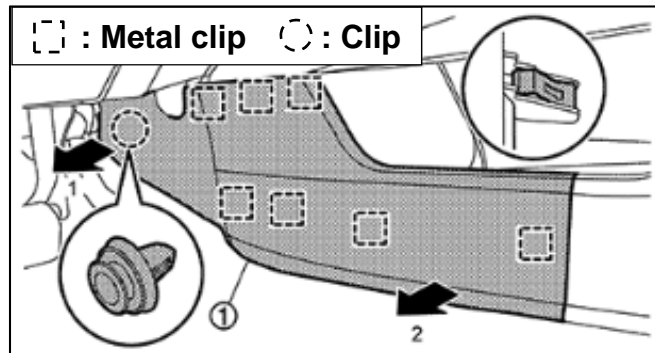

Figure 26

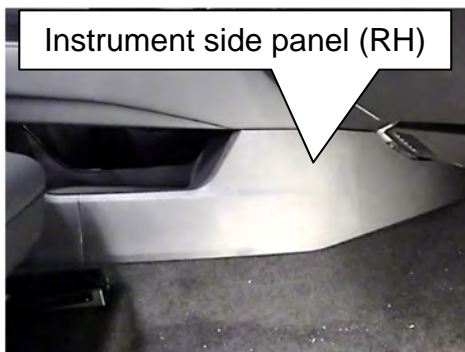

Figure 27

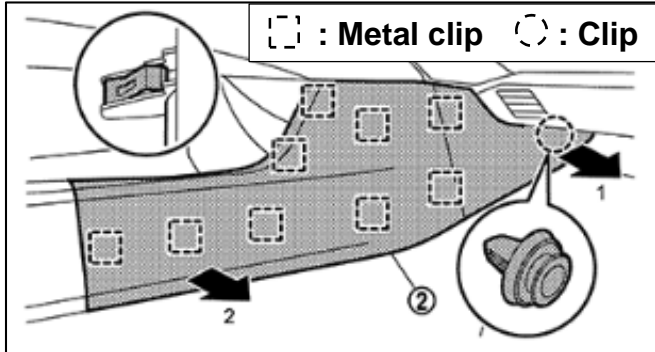

Figure 28

22. Remove the cup holder mat, and then remove the cup holder mounting screw.

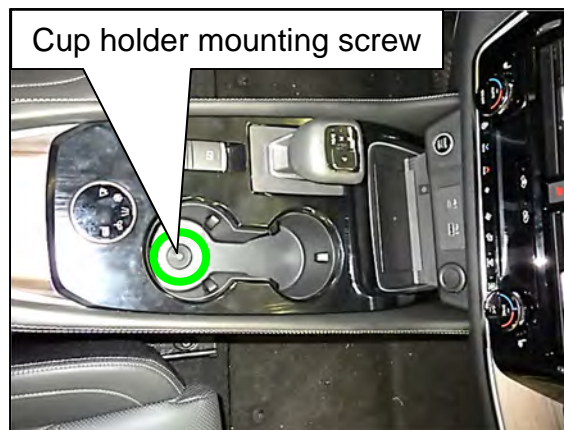

Figure 29

23. Apply protective tape (A) in the location shown in Figure 30, to protect it from damage.

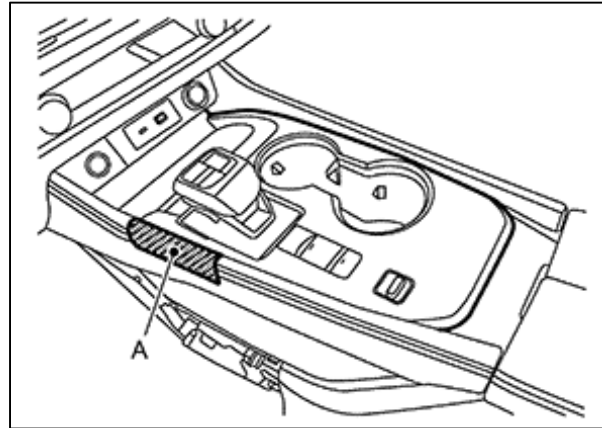

Figure 30

24. Pull up on the center console finisher assembly, as indicated by the arrow shown in Figure 32, to disengage the two (2) metal clips.



Figure 31

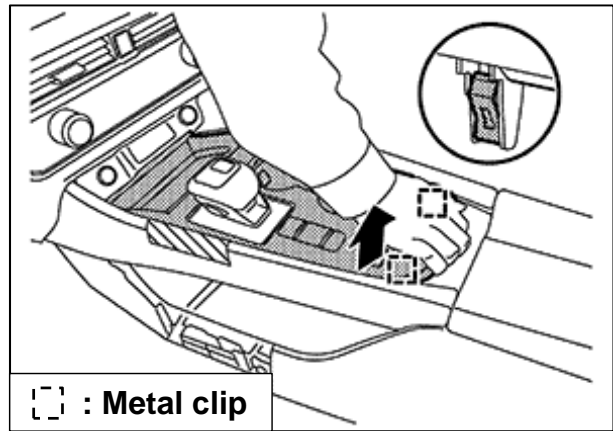

Figure 32

25. Using a remover tool, disengage the six (6) center console finisher assembly fixing pawls, as indicated by the arrows shown in Figure 33, and then pull up on the center console finisher assembly.

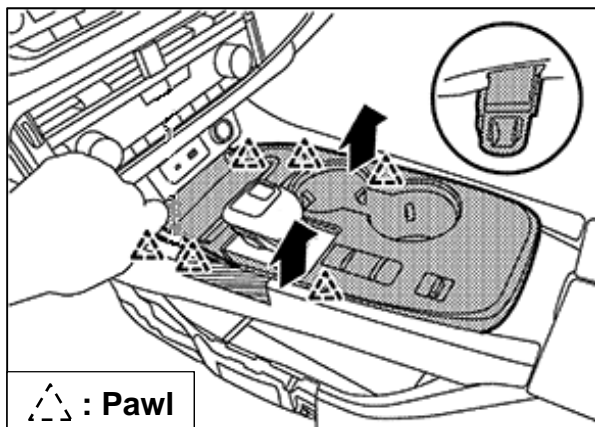

Figure 33



Figure 34

26. Disconnect the wire harness connectors, and then remove the center console finisher assembly.

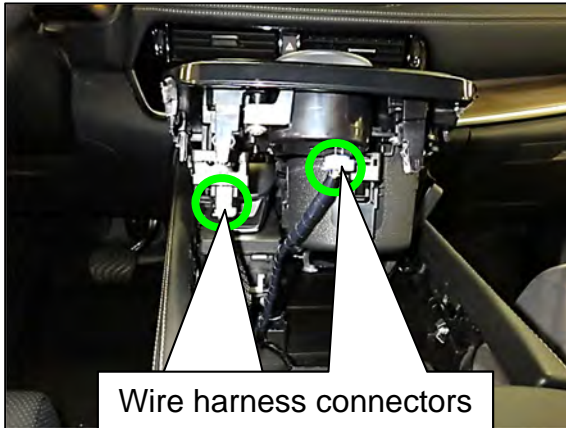

Figure 35

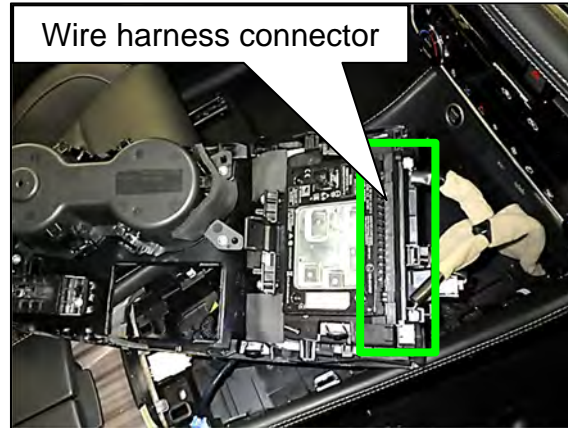

Figure 36

**⚠ WARNING**

The electric shift selector will be removed in steps 27 and 28. The electric shift selector contains a strong magnet. To avoid the risk of death or severe personal injury:

- People with an electro-medical apparatus should keep the electric shift selector away from their body. Otherwise, it may cause the electro-medial apparatus to malfunction.
- Keep the electric shift selector away from magnetic objects such as magnetic cards and metal items.
- Never subject the electric shift selector to impact by dropping or hitting it, water splash or high humidity.

27. Remove the four (4) bolts securing the electric shift selector, and then remove the electric shift selector.

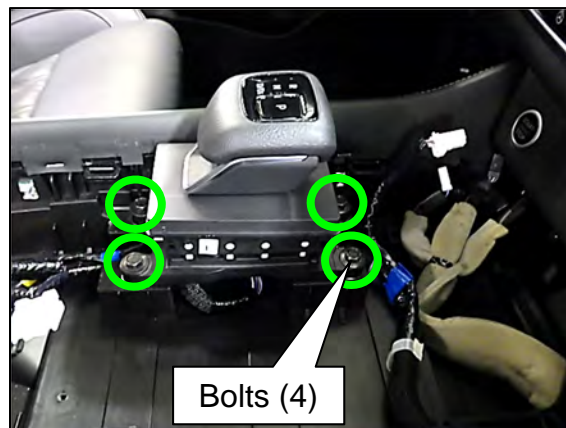

Figure 37

28. Disconnect the wire harness connector from the electric shift selector.

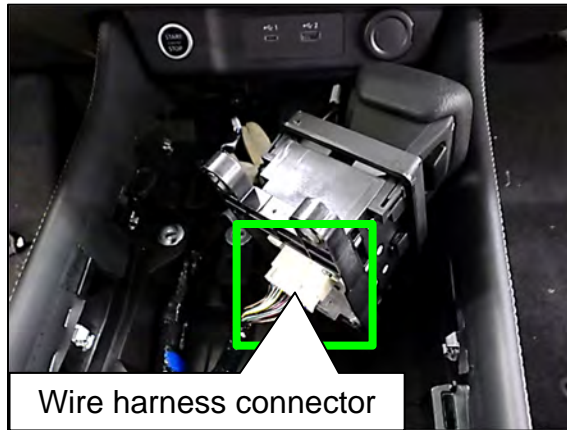

Figure 38

29. Open the center console lid and disengage the six (6) center console rear finisher fixing metal clips, as indicated by the arrows shown in Figure 40, and then pull out the center console rear finisher.



Figure 39

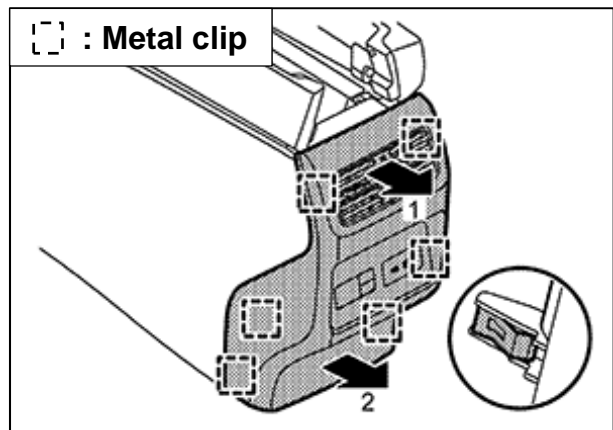

Figure 40

30. Disconnect the wire harness connectors, and then remove the center console rear finisher.

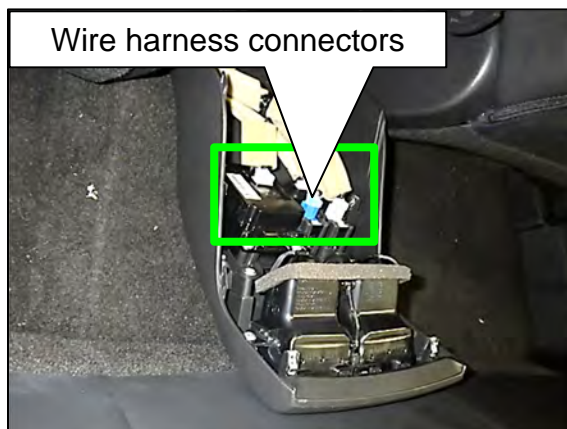

Figure 41

31. Remove the four (4) screws, two (2) bolts, and two (2) nuts securing the center console assembly, as shown in Figure 42 - Figure 45.

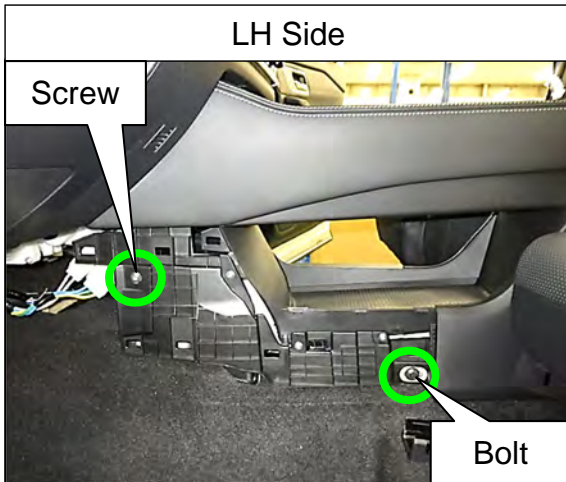

Figure 42

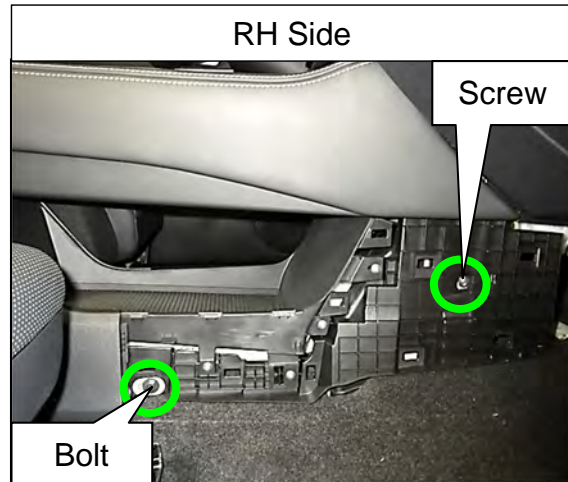

Figure 43

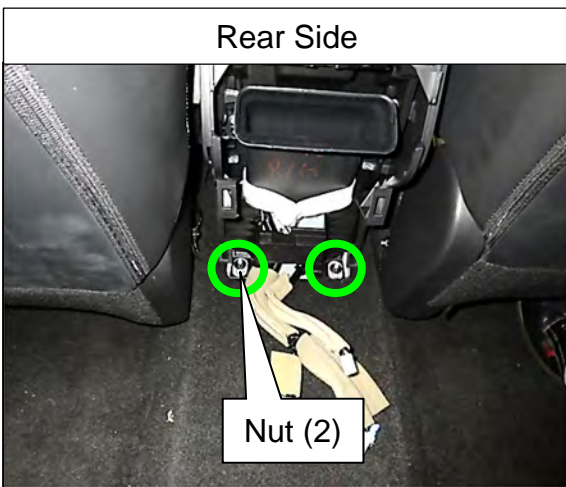

Figure 44

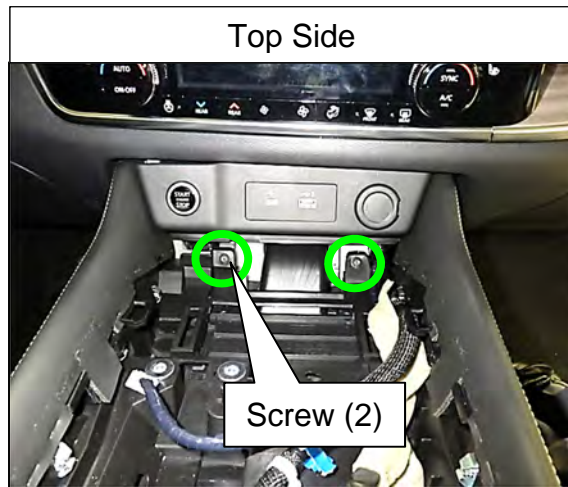

Figure 45

32. Disconnect the wire harness connectors, and then disengage the wire harness fixing clips (Figure 46).

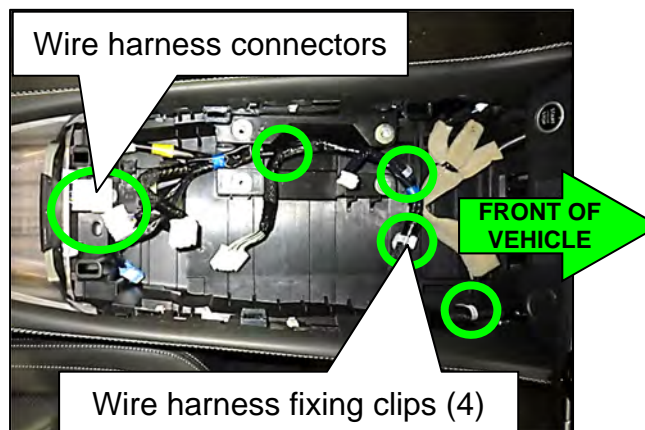

Figure 46

33. Disengage the two (2) fixing metal clips, as indicated by the arrow shown in Figure 47, and then remove the center console assembly.

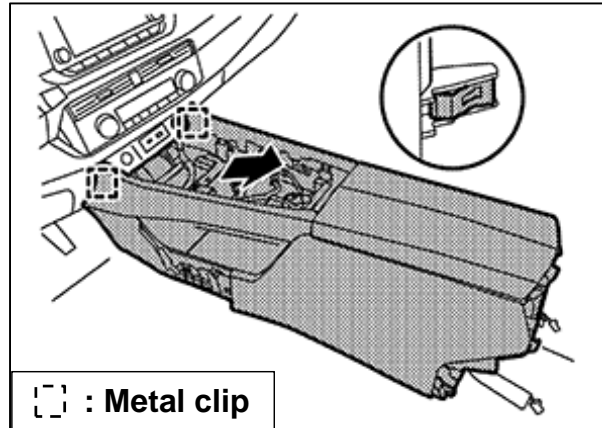

Figure 47

34. Remove the RH side body side welt, and then apply protective tape, as shown in Figure 48, to protect the instrument panel assembly from damage.

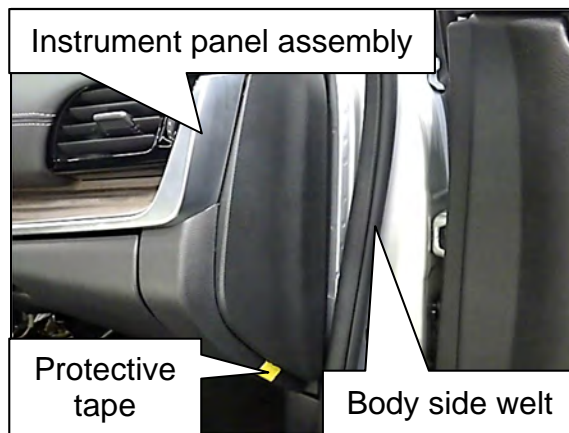

Figure 48

35. Using a remover tool, disengage the five (5) instrument mask fixing pawls, as indicated by the arrows shown in Figure 49, and then remove the RH instrument mask (Figure 50).

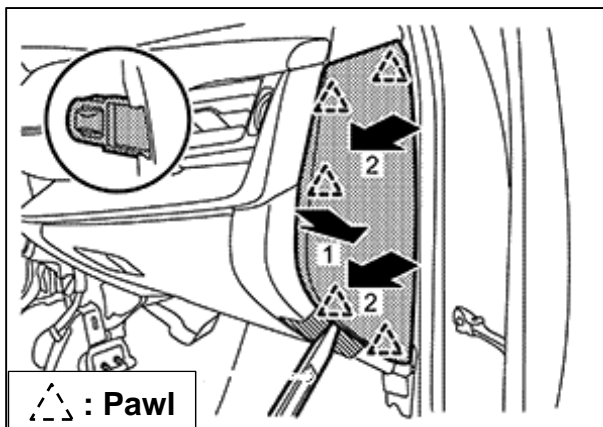

Figure 49



Figure 50



36. Remove the seven (7) glove box mounting screws (Figure 51 and Figure 52).

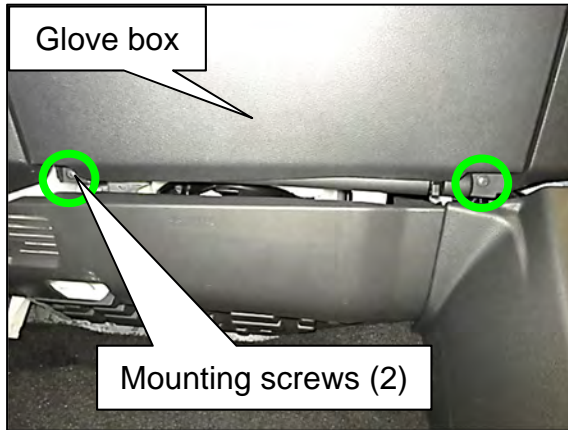

Figure 51

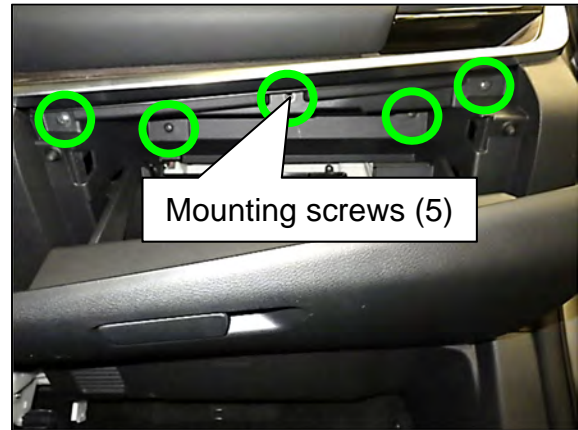

Figure 52

37. Disengage the three (3) glove box fixing metal clips, as indicated by the arrows shown in Figure 53, and then remove the glove box, as shown in Figure 54.

- If equipped, disconnect the wire harness connector (Figure 54).

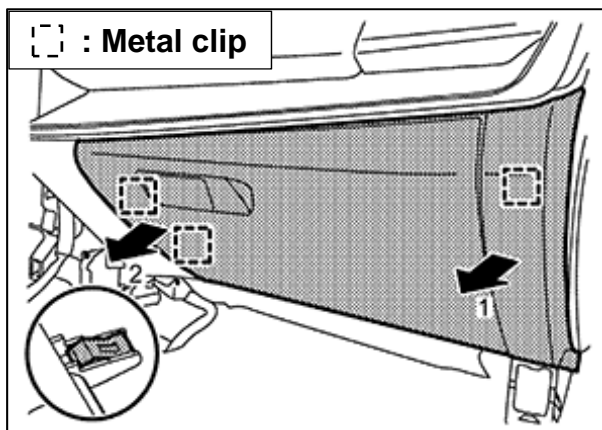

Figure 53

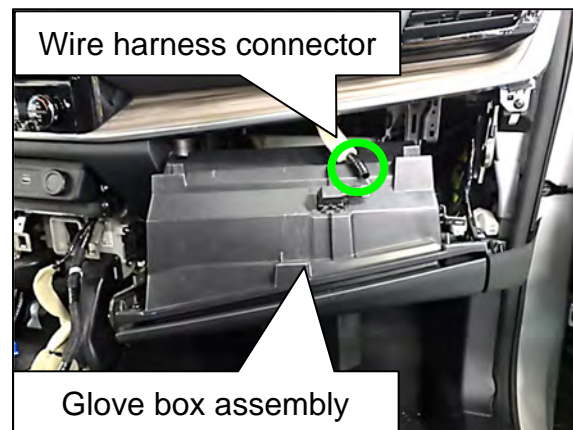

Figure 54

38. Remove the LH side body side welt, and then apply protective tape, as shown in Figure 55, to protect the instrument panel assembly from damage.

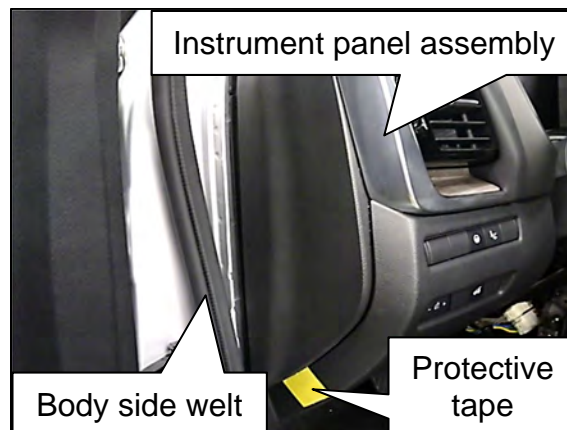

Figure 55

39. Using a remover tool, disengage the five (5) instrument mask fixing pawls, as indicated by the arrows shown in Figure 56, and then remove the LH instrument mask (Figure 57).

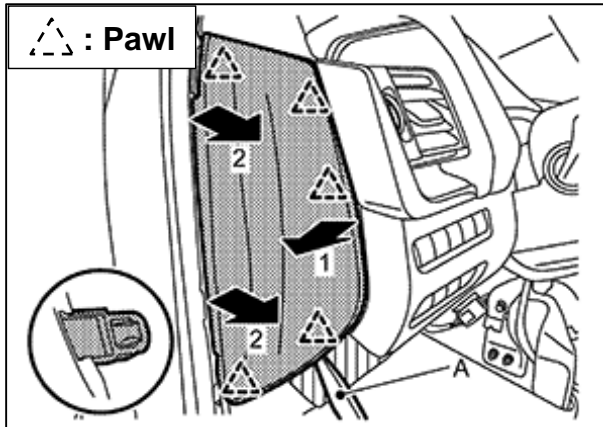

Figure 56



Figure 57

40. Disengage the four (4) fuse block lid fixing pawls, as indicated by the arrows shown in Figure 58, and then remove the fuse block lid (Figure 59).

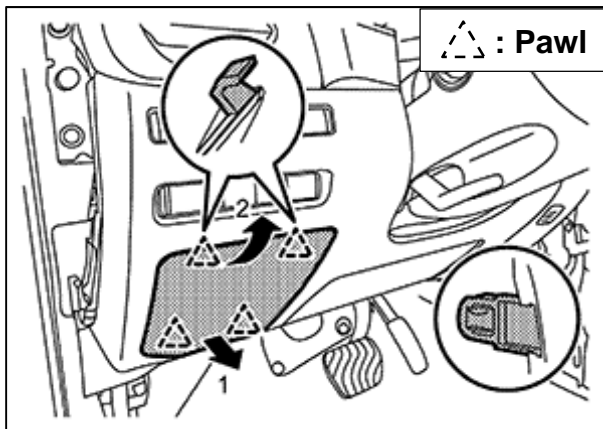

Figure 58



Figure 59

41. Remove the one (1) mounting screw, and then disengage the wire harness fixing clip.

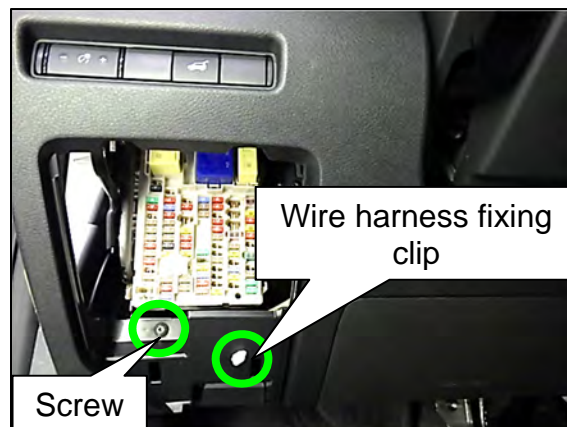

Figure 60

42. Disengage the four (4) LH instrument lower panel fixing pawls and five (5) metal clips, as indicated by the arrows shown in Figure 61.

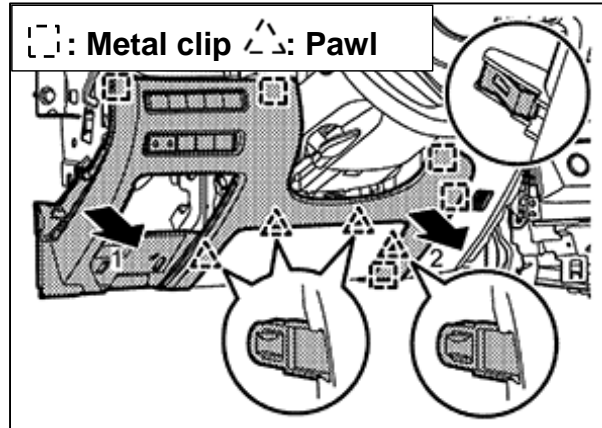

Figure 61

43. Disengage the wire harness fixing clip (Figure 62), disconnect the wire harness connectors, data link connector (Figure 63), and then remove the LH instrument lower panel.



Figure 62

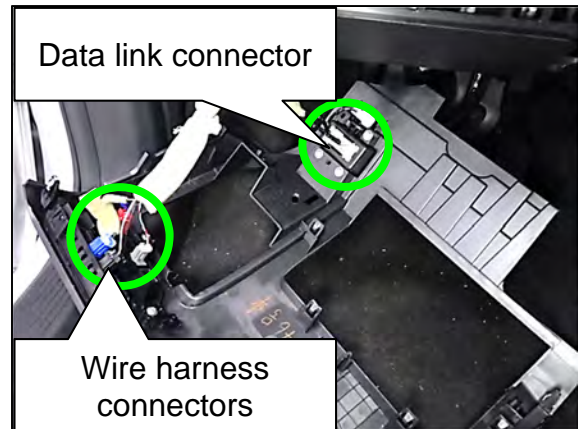

Figure 63

44. Remove the two (2) switch panel mounting screws.

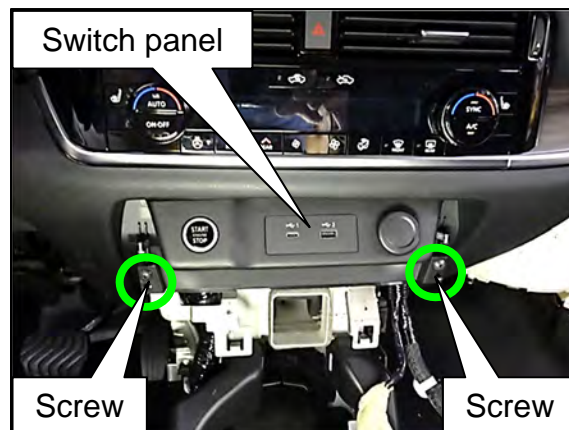

Figure 64

45. Disengage the two (2) switch panel fixing pawls, as indicated by the arrow in Figure 65, and then pull out the switch panel (Figure 66).

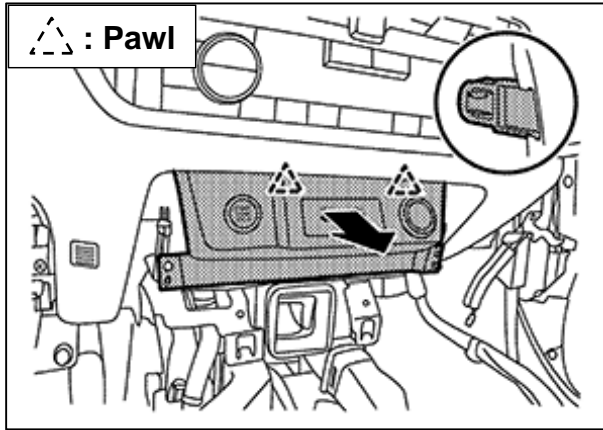

Figure 65

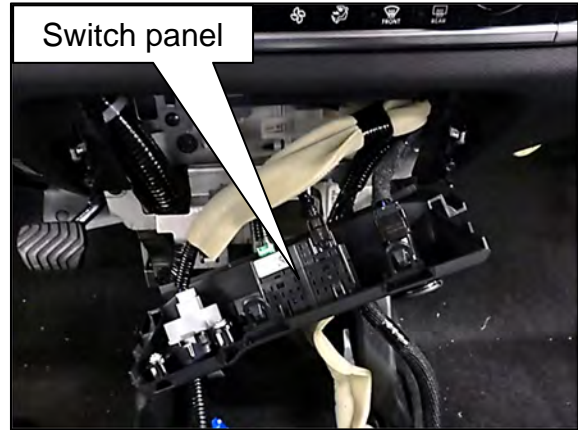

Figure 66

46. Disconnect the wire harness connectors, and then remove the switch panel.

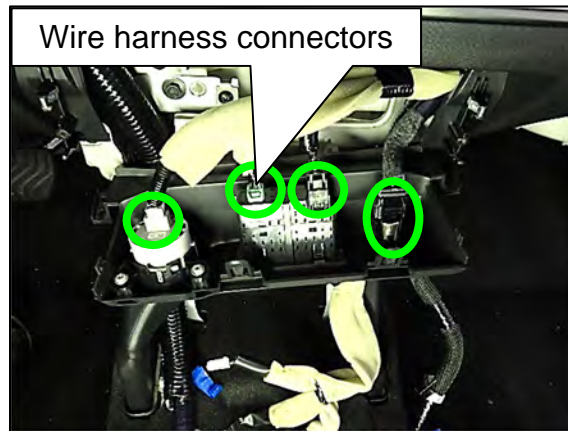

Figure 67

47. Apply protective tape to the center instrument lower panel to protect it from damage, as shown in Figure 68.

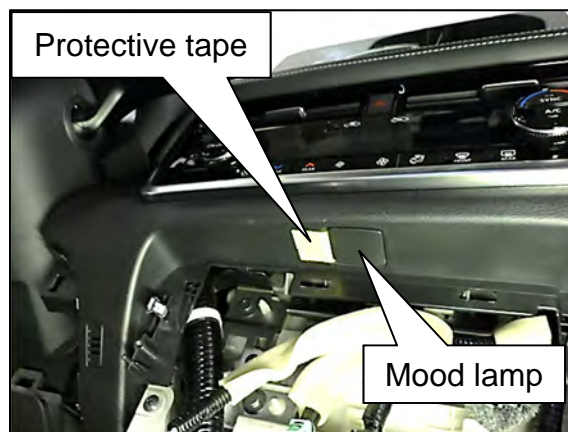

Figure 68

48. Using a remover tool, disengage the four (4) mood lamp fixing pawls, as indicated by the arrow in Figure 69.

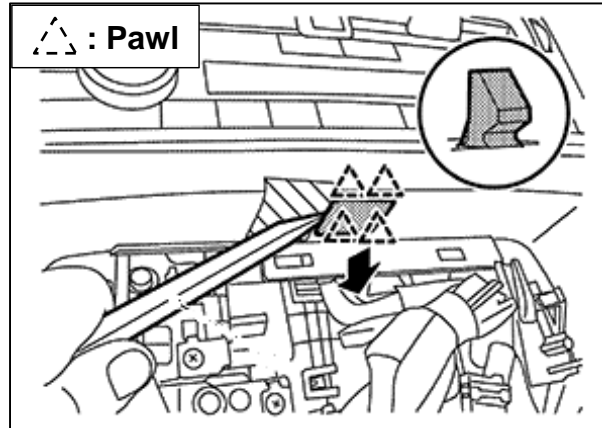

Figure 69

49. Disconnect the wire harness connector, and then remove the mood lamp.
50. Remove the two (2) mounting screws from the center instrument lower panel.

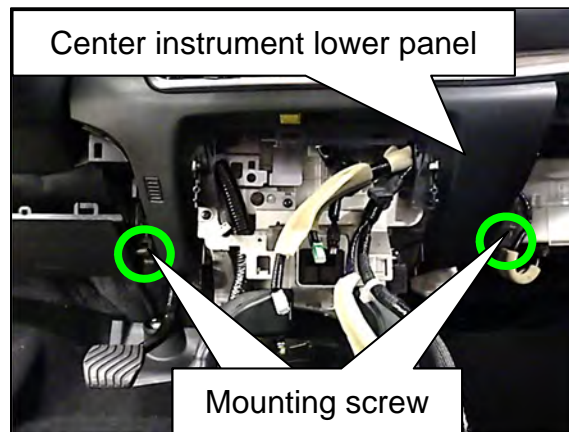

Figure 70

51. Disengage the five (5) center instrument lower panel metal clips, as indicated by the arrows in Figure 71, and then pull out the center instrument lower panel (Figure 72).

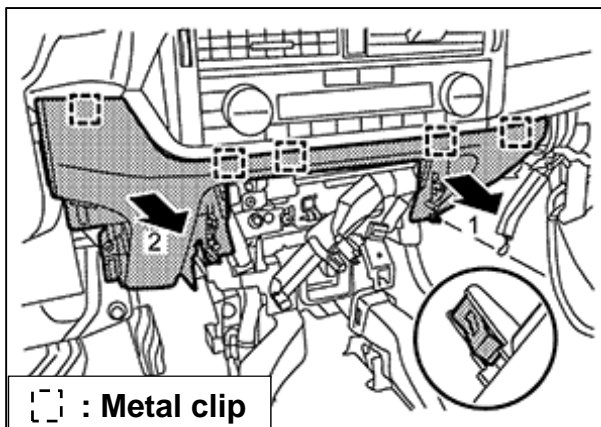

Figure 71



Figure 72

52. Disconnect the wire harness connector and, if equipped, the aspirator duct, and then remove the center instrument lower panel.

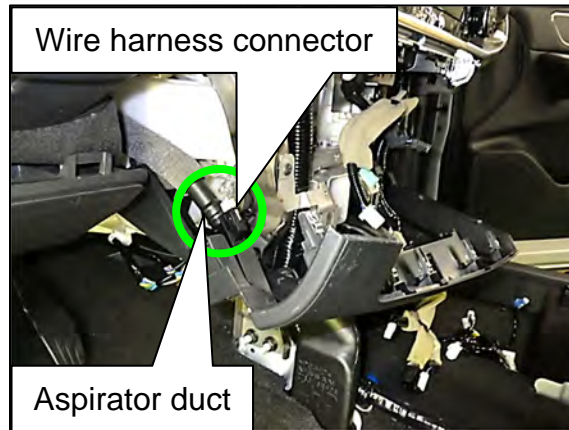

Figure 73

**⚠ WARNING**

To avoid the risk of death or severe personal injury:

- Never allow oil, grease, detergent, or water to come in contact with an airbag module.
- Never insert any foreign objects into the airbag module.
- Never reuse airbag module mounting bolts or screws after removal, replace with new mounting bolts or screws.
- Replace the airbag module if it is dropped or sustains an impact.
- Always place an airbag module with the deploying direction facing upward (Figure 74).

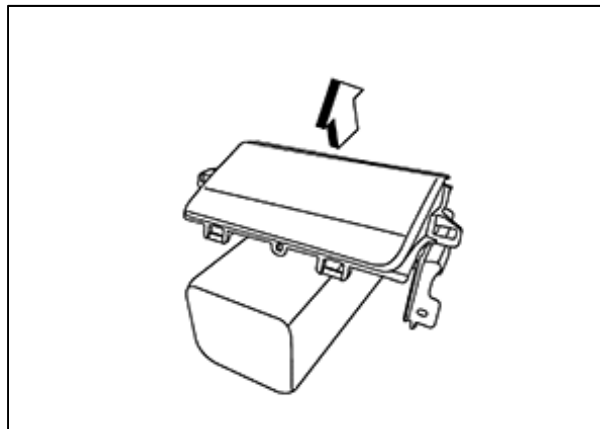

Figure 74

53. Remove the two (2) driver knee airbag module mounting bolts, and then pull out the driver knee airbag module.
- Discard the airbag module mounting bolts, they will not be reused.

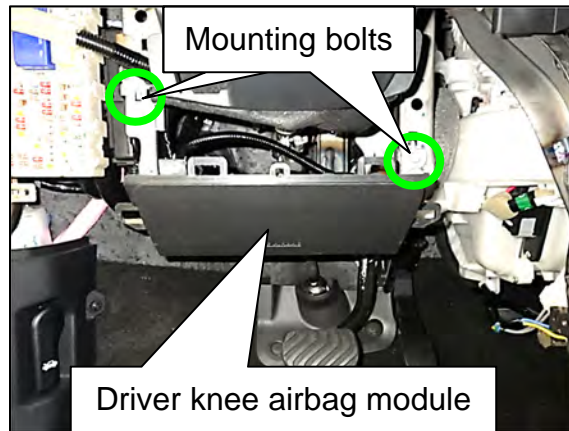

Figure 75

54. Disconnect the wire harness connector, disengage the wire harness fixing clips, and then remove the driver knee airbag module.

**HINT:** For removing the wire harness connector:

- a. Insert a thin flat blade screwdriver wrapped in tape into the notch
- b. Lift the lock
- c. Remove the wire harness connector.

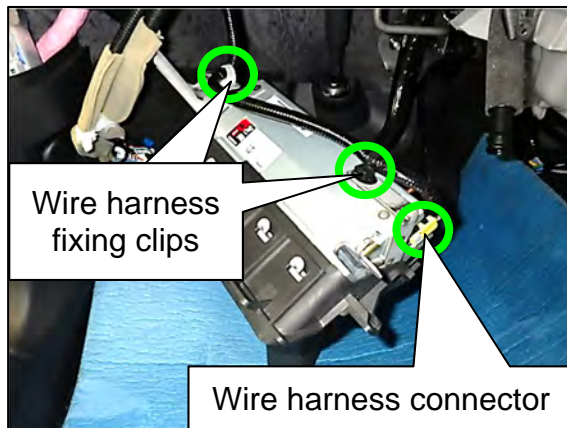

Figure 76

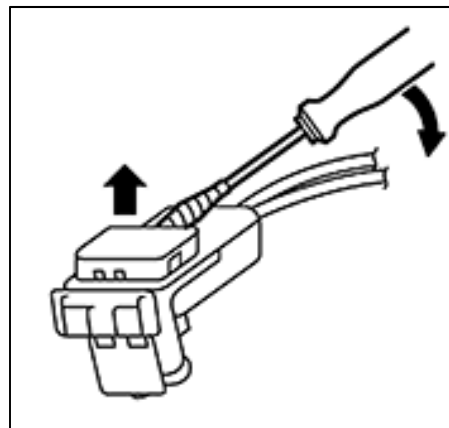

Figure 77

55. Unlock the steering wheel tilt/telescope adjustment lever and place the steering wheel to the lowest level, disengage the four (4) fixing pawls, as indicated by the arrow shown in Figure 79, and then remove the skirt portion of cluster lid A.

**NOTE:** The steering wheel does not need to be removed.

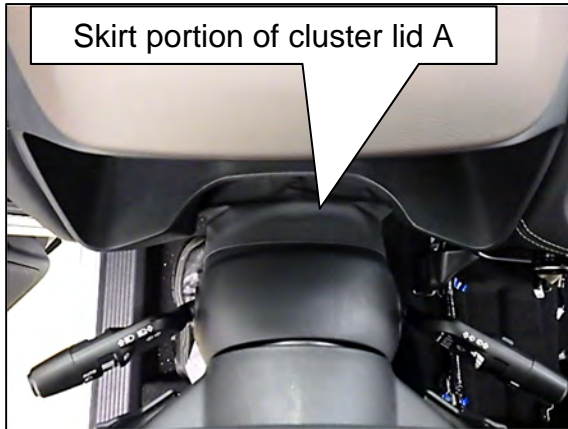

Figure 78

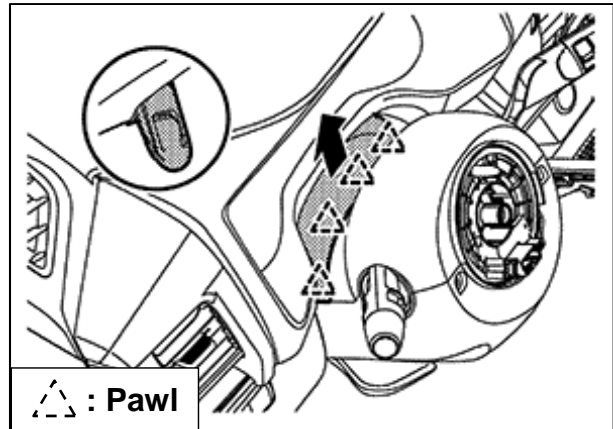

Figure 79

56. Disengage the two (2) cluster lid A fixing pawls and the four (4) metal clips, as indicated by the arrows in Figure 81, and then remove the cluster lid A.

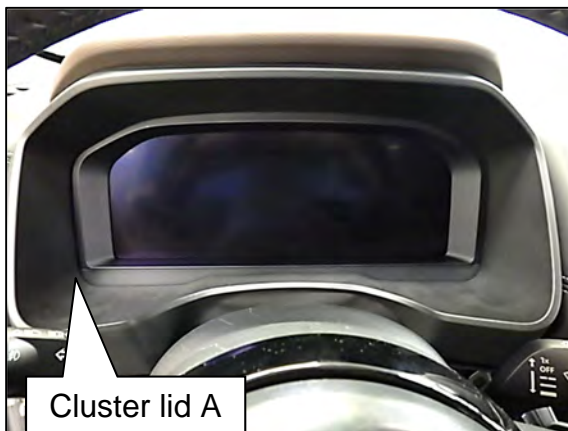

Figure 80

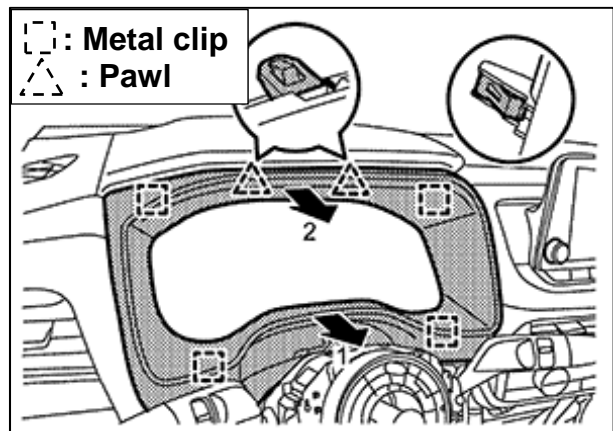

Figure 81



57. Remove the two (2) steering column assembly upper mounting bolts.

**HINT:** Support the steering column assembly with one hand while removing the bolts with the other.



Figure 82

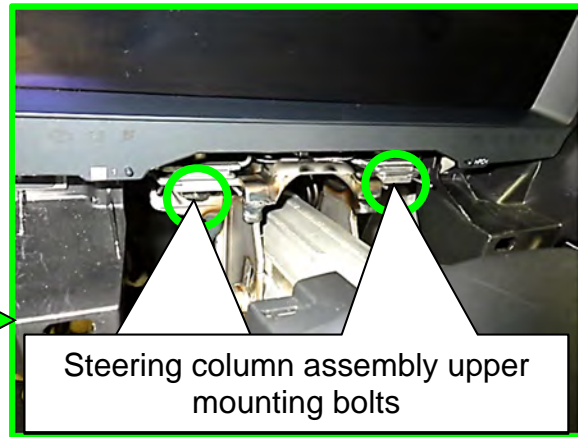

Figure 83

58. Slightly pull the steering column out just enough to rest the steering wheel on the driver seat cushion, as shown in Figure 85.

**IMPORTANT:** Carefully lift the steering column to unlatch it from the dash, and then pull it out slightly to rest it on the driver seat. Do not excessively pull on the steering column as the steering column shaft will over-extend and the shaft splines will disengage.



Figure 84



Figure 85

59. Remove the three (3) combination meter mounting screws (Figure 86), and then pull the combination meter outward (Figure 87).

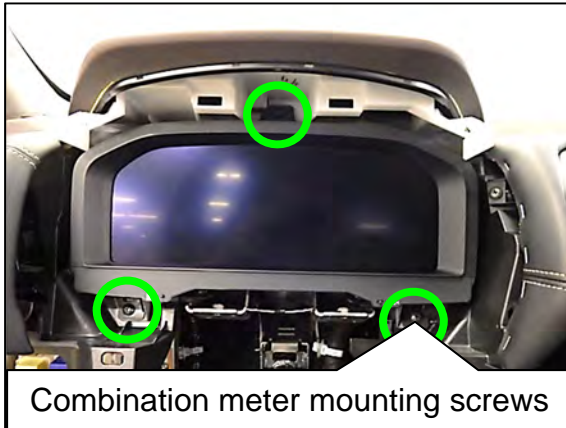

Figure 86

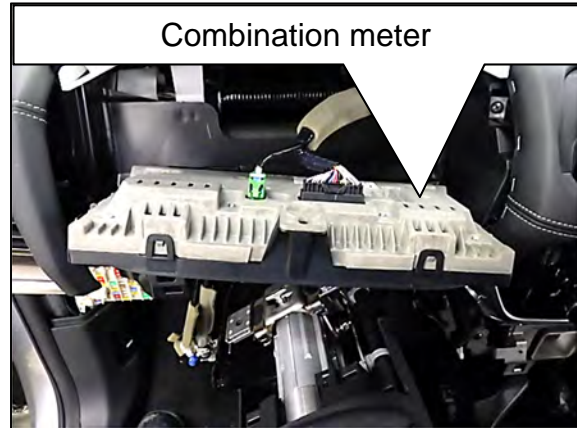

Figure 87

60. Disconnect the wire harness connectors (Figure 88), and then remove the combination meter (Figure 89).

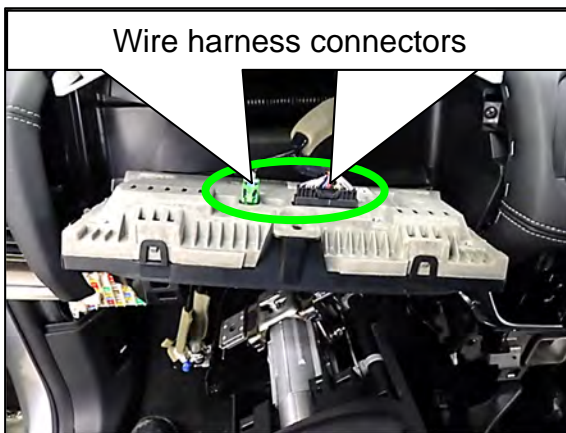

Figure 88



Figure 89

61. Disengage the four (4) LH ventilator grille assembly metal clips, as indicated by the arrow in Figure 91, and then remove the LH ventilator grille and instrument pad A as an assembly.



Figure 90

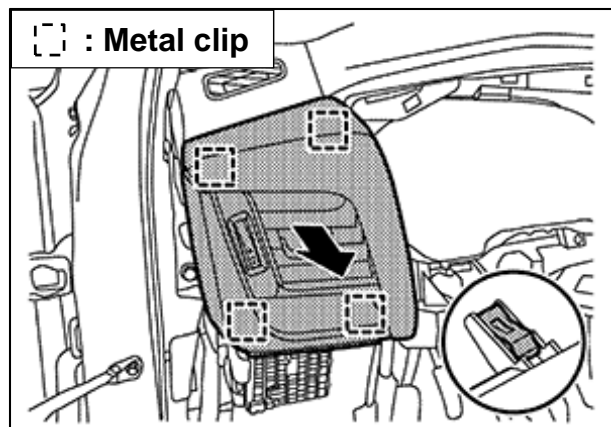

Figure 91

62. Remove the one (1) instrument pad B mounting screw.

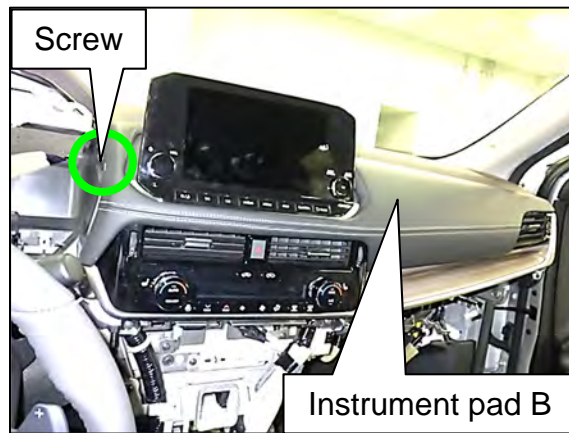

Figure 92

63. Disengage the two (2) instrument pad B fixing pawls and fifteen (15) metal clips, as indicated by the arrows in Figure 93, and then remove instrument pad B (Figure 94).

**NOTICE**

To avoid damage to the AV control unit surface, cover the AV control unit with a clean shop cloth prior to removing instrument pad B.

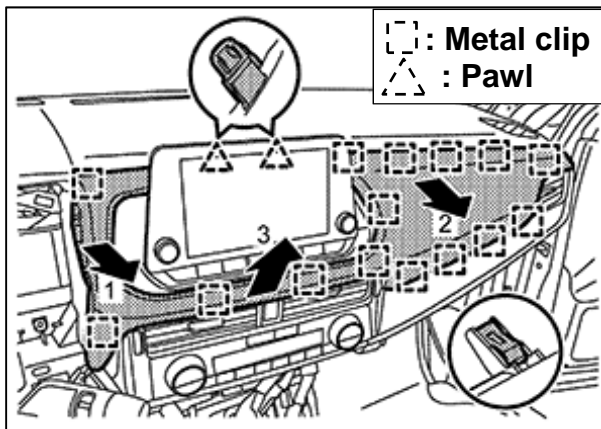

Figure 93



Figure 94

64. Remove the four (4) AV control unit mounting bolts.

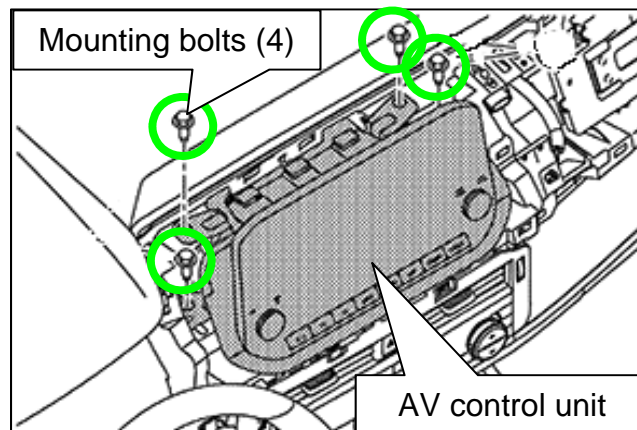

Figure 95

65. Pull the AV control unit outward, remove the wire harness connectors (Figure 96), and then remove the AV control unit.

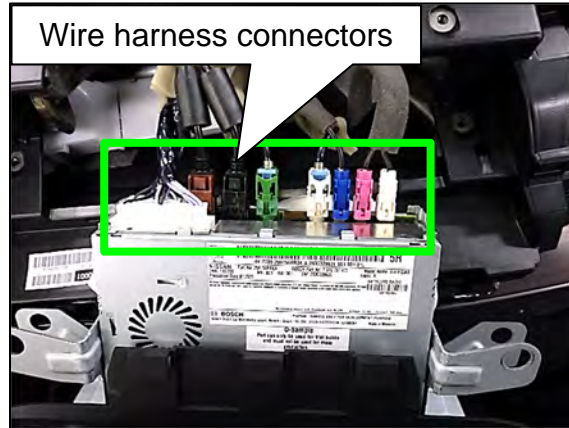

Figure 96

66. Remove the three (3) A/C switch assembly mounting screws.

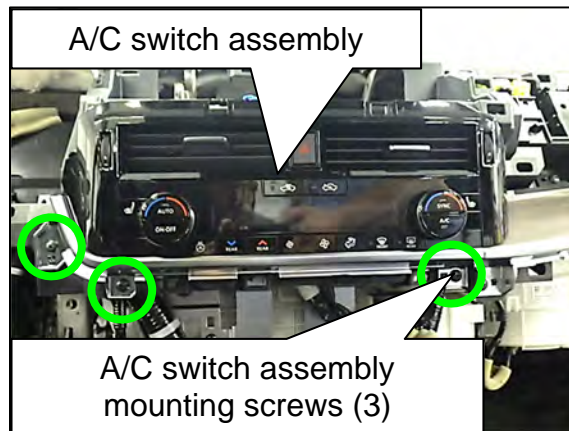

Figure 97

67. Disengage the two (2) A/C switch assembly fixing pawls and five (5) metal clips (Figure 98), and then pull out the A/C switch assembly (Figure 99).

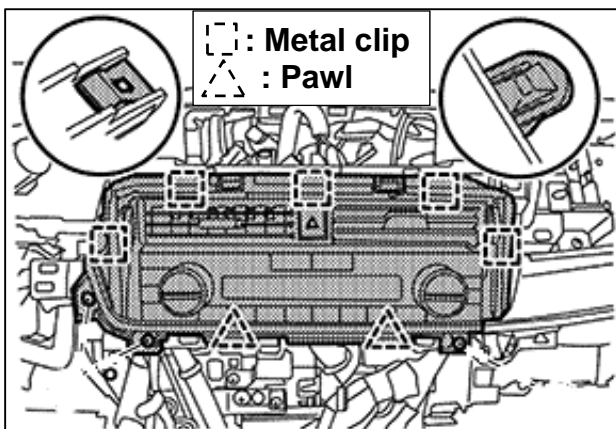

Figure 98

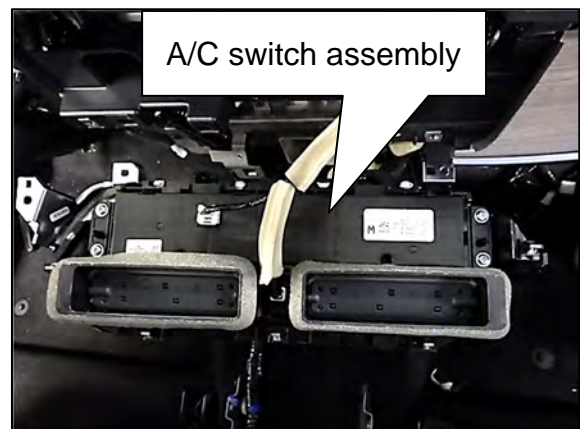

Figure 99

68. Disconnect the wire harness connectors, disengage the wire harness fixing clip, and then remove the A/C switch assembly.

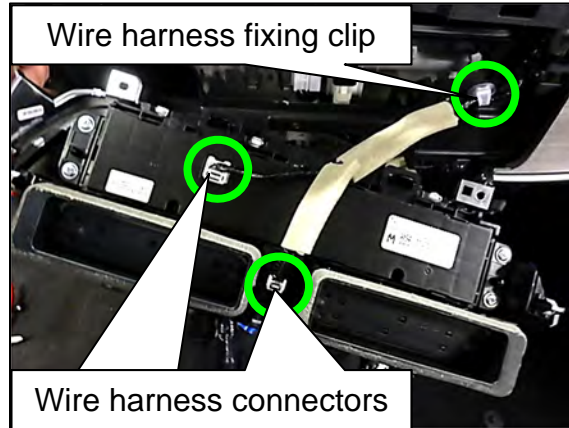

Figure 100

69. Remove the two (2) Intelligent Key unit mounting screws, disconnect the wire harness connector, and then remove the Intelligent Key unit.

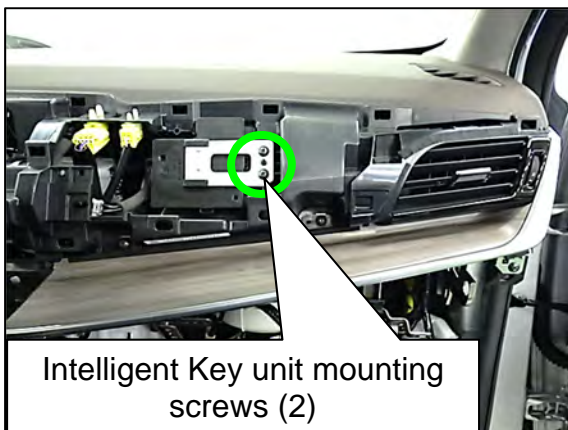

Figure 101

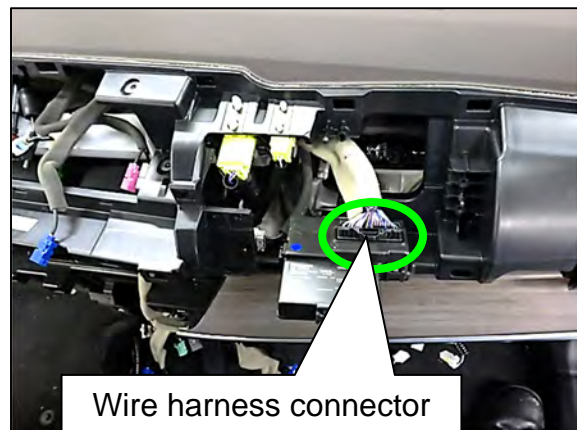

Figure 102

70. Remove the four (4) RH side ventilator grille assembly mounting screws.

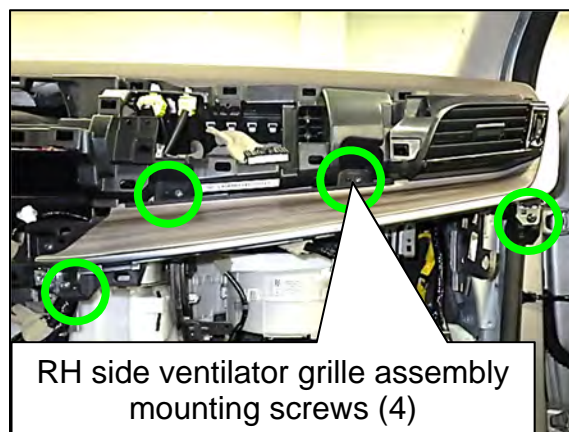

Figure 103

71. Disengage the seven (7) RH side ventilator grille assembly metal clips, as indicated by the arrows shown in Figure 104, and then remove the RH side ventilator grille assembly.

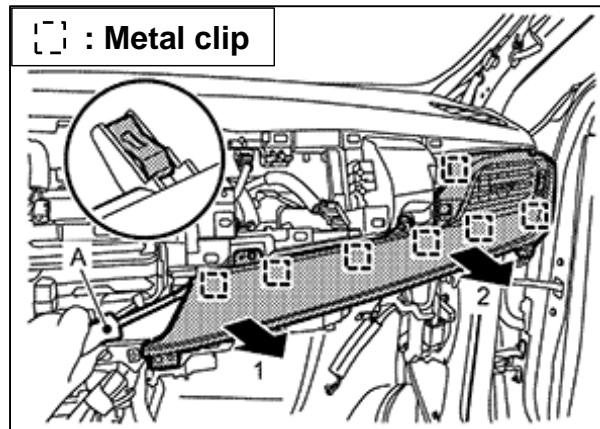

Figure 104

72. Apply protective tape to the RH side of the instrument panel assembly, as shown in Figure 105.



Figure 105

73. Disengage the one (1) RH front pillar garnish (RH A-pillar trim) metal clip and the one (1) anchor clip, as indicated by the arrows in Figure 106.

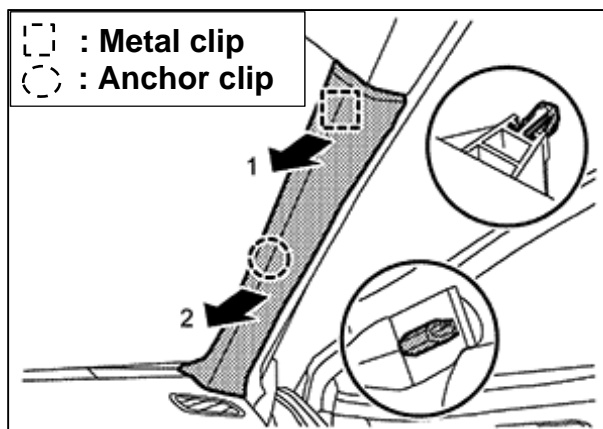

Figure 106



Figure 107

74. Cut the anchor clip, as shown in Figure 108 and Figure 109.

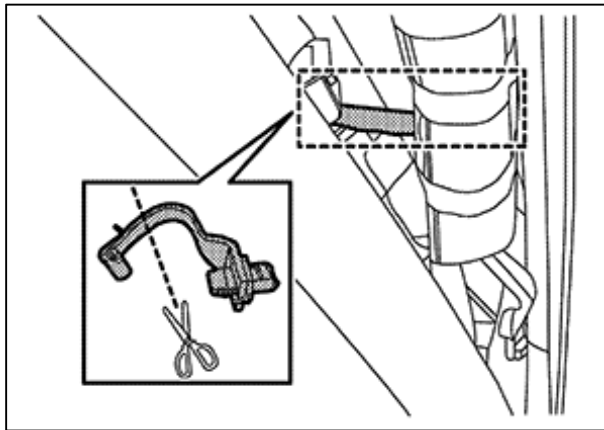

Figure 108

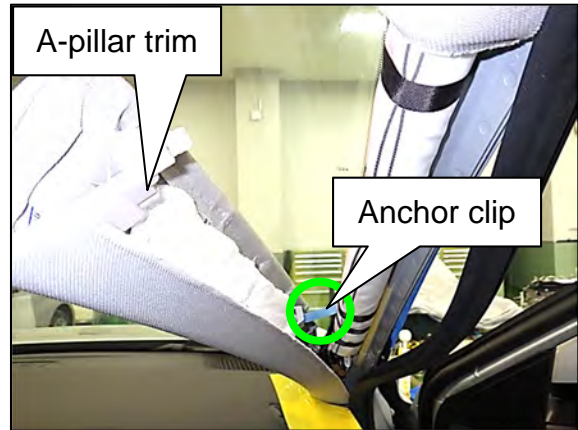

Figure 109

75. Disengage the RH A-pillar trim fixing portion, as indicated by the arrow in Figure 110, and then remove the RH A-pillar trim.

- If equipped, disconnect the tweeter wire harness connector (Figure 111).

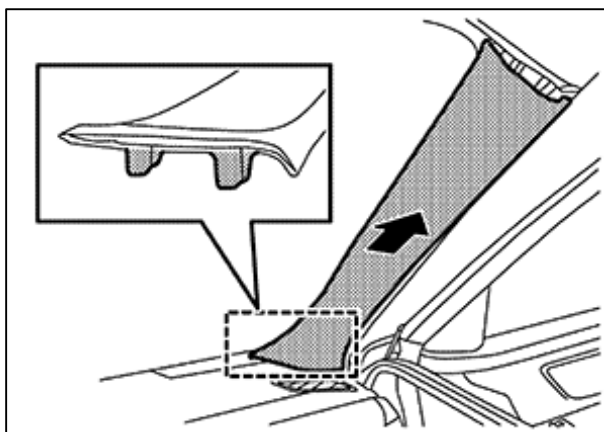

Figure 110



Figure 111

76. Remove the anchor clip from the RH A-pillar and replace with a new one.



Figure 112

77. Using a remover tool, disengage the three (3) RH speaker grille fixing pawls, as indicated by the arrow in Figure 114, and then remove the RH speaker grille.

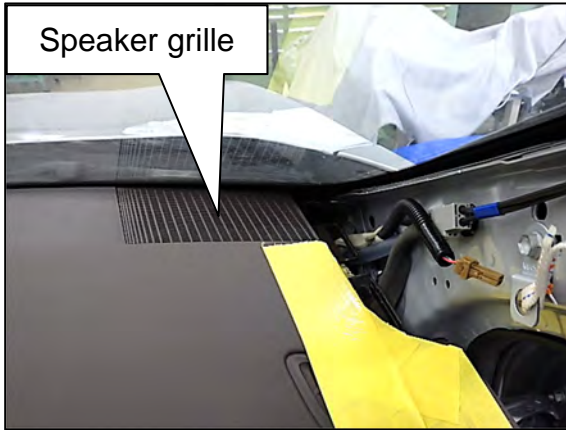

Figure 113

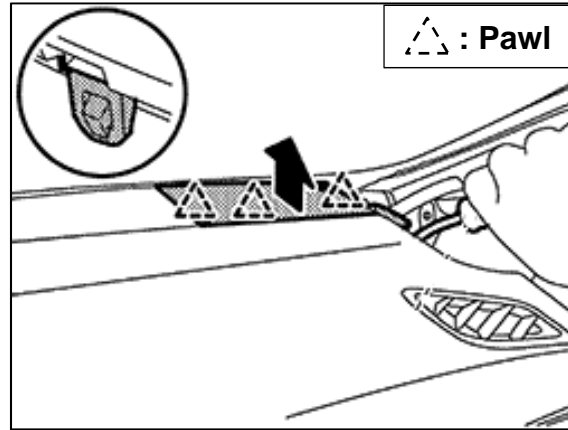

Figure 114

78. Remove the three (3) RH speaker mounting bolts, disconnect the speaker wire harness connector, and then remove the RH speaker from the instrument panel.

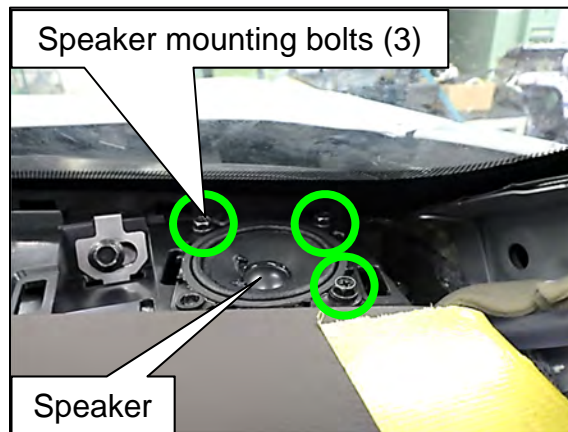

Figure 115

79. Perform steps 72 - 78 for the LH side.
80. Apply protective tape to the instrument panel in between the optical sensor and the sunload sensor, as shown in Figure 116.

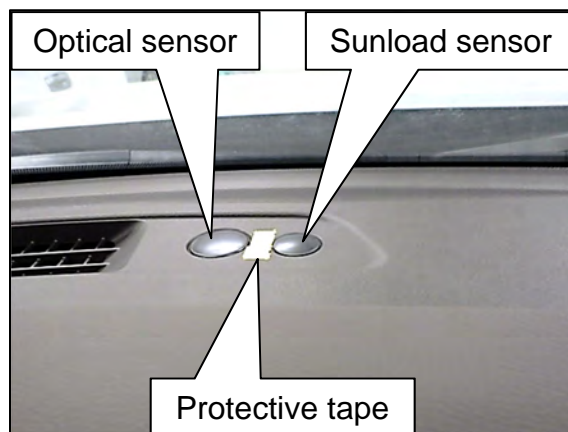

Figure 116



81. Using a remover tool, disengage the optical sensor and sunload sensor fixing pawls (Figure 117), and then pull the sensors from the instrument panel (Figure 118).



Figure 117

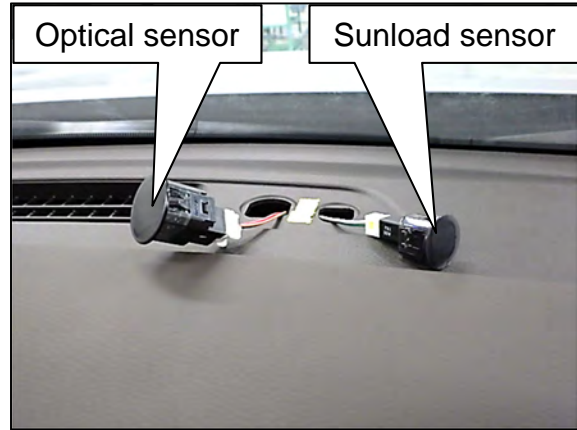

Figure 118

82. Disconnect the wire harness connectors from the optical sensor and the sunload sensor, and then remove both sensors.
83. Disengage the five (5) instrument panel garnish (trim) fixing pawls and eleven (11) metal clips, as indicated by the arrows in Figure 120, and then remove the instrument panel trim.



Figure 119

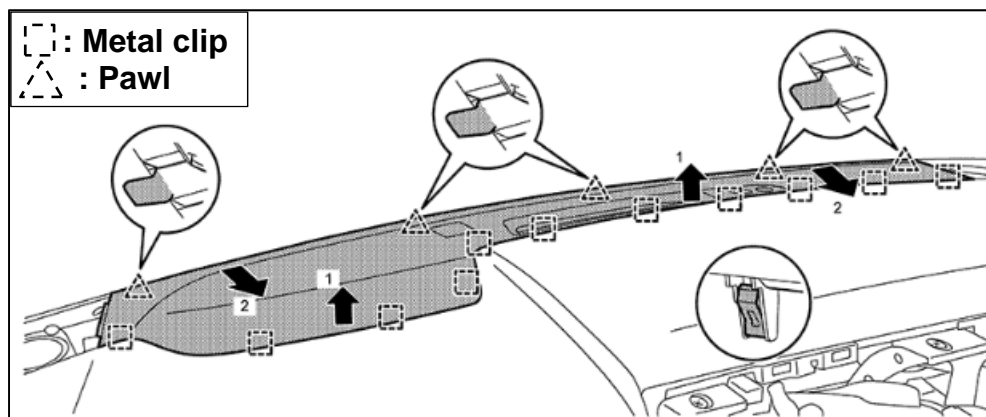

Figure 120

84. Remove the two (2) meter speaker mounting bolts, and then pull out the meter speaker.

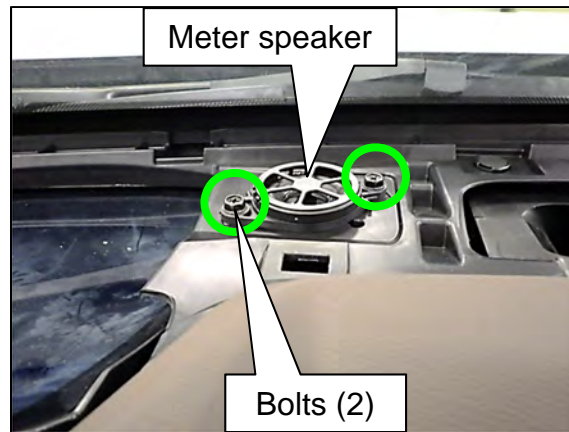

Figure 121

85. Disconnect the meter speaker wire harness connector, and then remove the meter speaker.
86. Disconnect the passenger airbag module wire harness connectors, and then disconnect the gray GPS/Telematics antenna wire harness connector, if equipped.

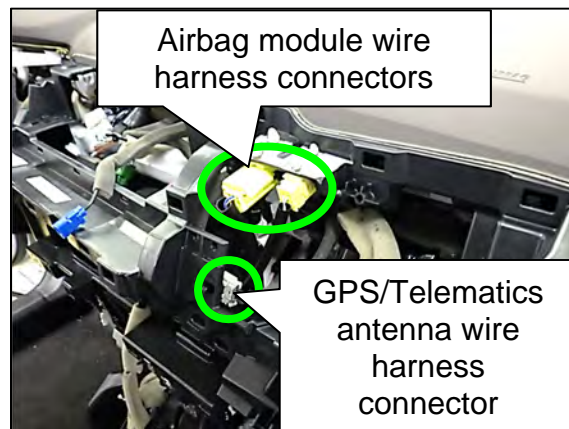

Figure 122

87. Remove the two (2) airbag module mounting bolts.
- Discard the airbag module mounting bolts, they will not be reused.

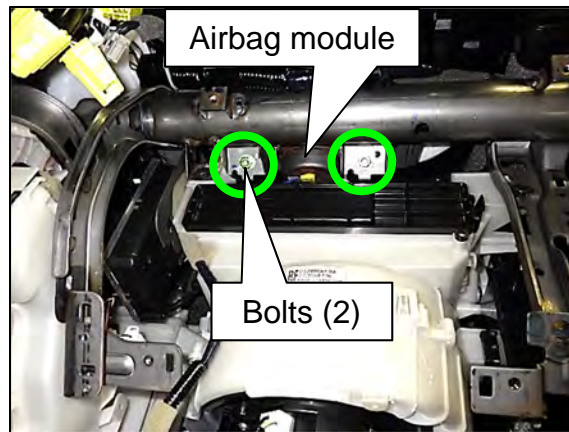

Figure 123

88. Disengage the three (3) instrument panel fixing clips.
- HINT:** Take care not to drop the instrument panel fixing clips into the defroster ducts.

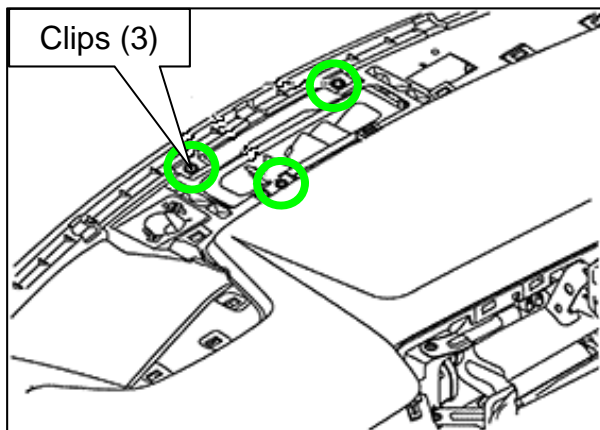

Figure 124

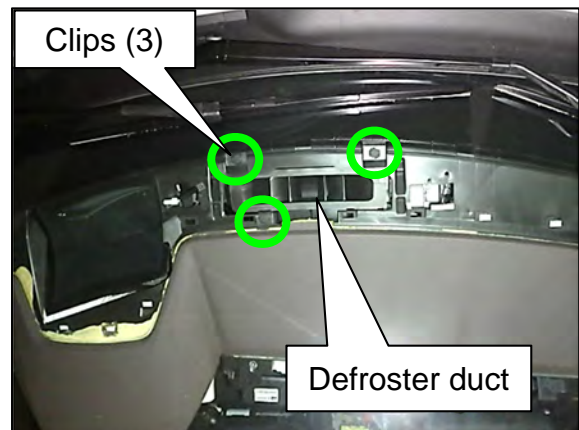

Figure 125

89. Remove the one (1) instrument panel mounting bolt (B) and ten (10) mounting screws (A).

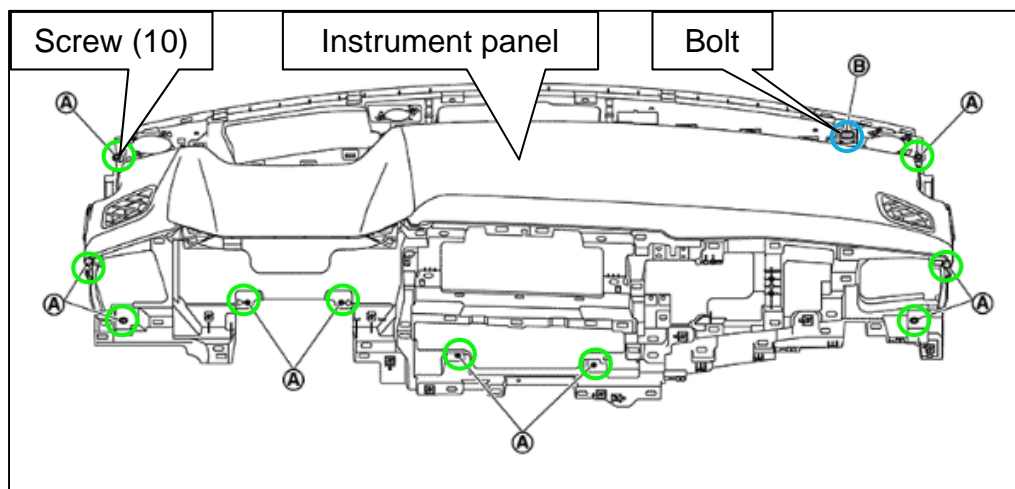

Figure 126

90. Remove the instrument panel from the passenger side door opening.

**HINT:** The passenger side of the dash must be lifted high enough for the passenger side airbag to clear the dash frame.

**NOTICE**

To avoid damage to the instrument panel, 2 people are needed to remove the instrument panel from the vehicle.

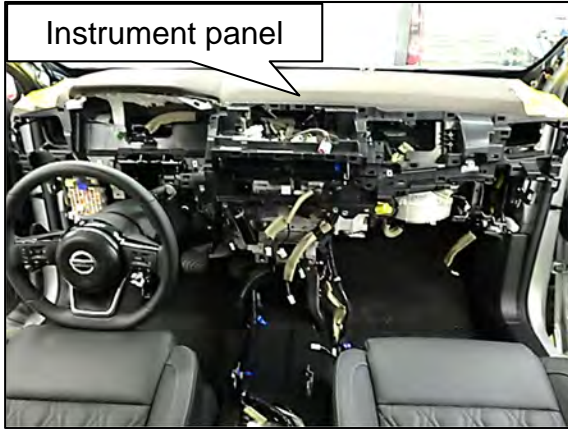

Figure 127

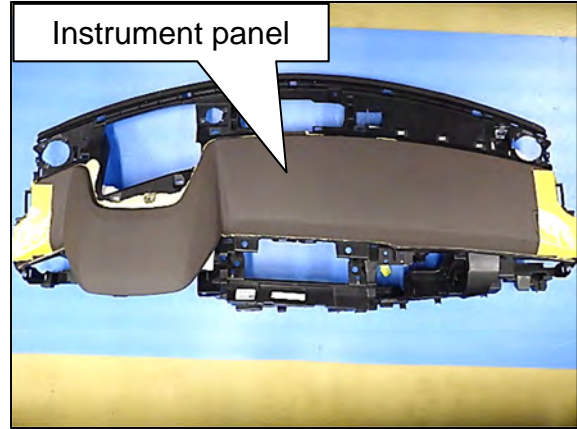

Figure 128

**WARNING**

To avoid the risk of death or severe personal injury:

- Never allow oil, grease, detergent, or water to come in contact with an airbag module.
- Never insert any foreign objects into the airbag module.
- Replace the airbag module if it is dropped or sustains an impact.
- Always place an airbag module with the deploying direction facing upward (Figure 129).
- Always use new airbag module mounting bolts and screws.

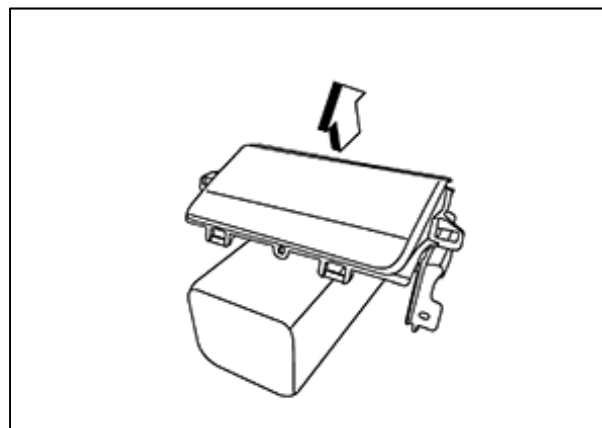

Figure 129

91. Remove the two (2) passenger airbag module mounting screws and discard, they will not be reused.

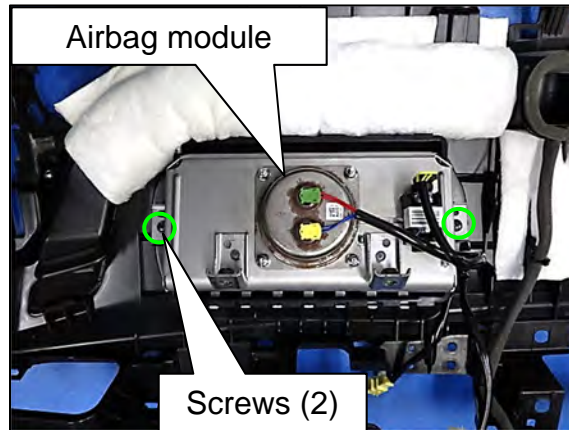

Figure 130

92. Remove the passenger airbag module from the instrument panel in the order shown in Figure 131 and Figure 132.

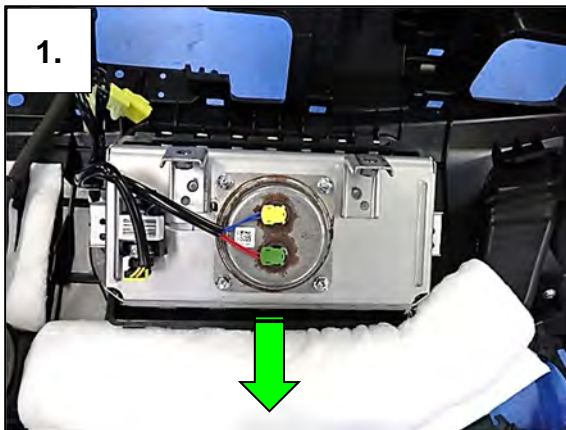

Figure 131

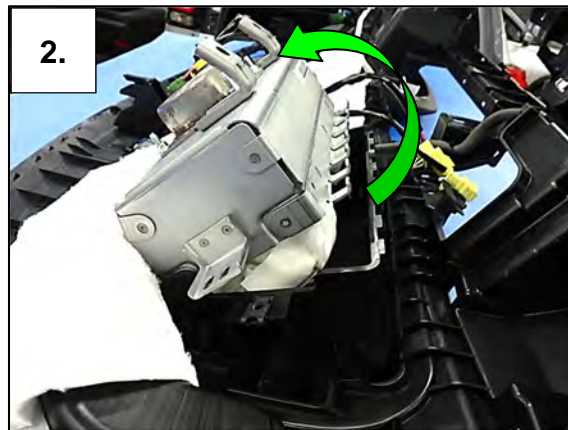

Figure 132

93. Install the new passenger airbag module in the reverse order of removal.
94. Install the instrument panel in the reverse order of removal.
- Verify the (3) clips, (10) screws and (1) bolt are reinstalled.
  - Verify the two pin gray GPS/Telematics connector is plugged in, if equipped (step 86 on page 34).
  - Verify all speaker, optical sensor, sunload sensor, combination meter, Intelligent Key unit, A/C switch, and AV control unit wire harnesses are properly routed through the appropriate instrument panel locations.

95. Install and tighten **new** passenger airbag module mounting bolts.
    - Always use new airbag module mounting bolts.
    - Passenger airbag module mounting bolt torque: 22.3 N•m (2.3 kg-m, **16 ft-lb**)
    - Connect the GPS/Telematics wire harness connector, if equipped.
  96. Install the meter speaker in the reverse order of removal.
  97. Install the instrument panel trim in the reverse order of removal.
  98. Install the optical sensor and sunload sensor in the reverse order of removal.
    - Remove the protective tape from the instrument panel after installation.
  99. Install the LH and RH instrument panel speaker and speaker grille in the reverse order of removal.
  100. Install **new** anchor clips on the LH and RH A-pillar, and then install the LH and RH A-pillar trim in the reverse order of removal.
    - Remove the protective tape from the instrument panel after installation.
  101. Install the RH side ventilator grille assembly in the reverse order of removal.
  102. Install the Intelligent Key unit in the reverse order of removal.
  103. Install the A/C switch and Center Ventilator Grille assembly in the reverse order of removal.
    - Install wire harness fixing clip.
  104. Install the AV control unit in the reverse order of removal.
  105. Install the instrument pad B in the reverse order of removal.
- NOTICE**
- To avoid damage to the AV control unit surface, cover the AV control unit with a clean shop cloth prior to installing the instrument pad B.

106. Install the LH side ventilator grille assembly in the reverse order of removal.

107. Install the combination meter in the reverse order of removal.
108. Install the steering column assembly in the reverse order of removal.
- IMPORTANT:** Do not excessively pull on the steering column as the steering column shaft will over-extend and the shaft splines will disengage.
- Steering column upper mounting bolt torque: 16.7 N•m (1.7 kg-m, **12 ft-lb**)
109. Install the cluster lid A in the reverse order of removal.
110. Install the driver knee airbag in the reverse order of removal.
- Always use **new** airbag module mounting bolts.
  - Install wire harness fixing clips.
  - Verify that the wire harness connector lock is fully seated.
  - Driver knee airbag module mounting bolt torque: 8.0 N•m (0.8 kg-m, **71 in-lb**)
111. Install the center instrument lower panel in the reverse order of removal.
- Connect the wire harness connector and aspirator tube, if equipped.
112. Install the mood lamp in the reverse order of removal.
- Remove the protective tape from the instrument panel after installation.
113. Install the switch panel in the reverse or of removal.
114. Install the LH instrument lower panel in the reverse order of removal.
- Install the wire harness fixing clip.
  - Connect the wire harness connectors and the data link connector
115. Install the fuse block lid in the reverse order of removal.
116. Install the LH instrument mask in the reverse order of removal.
- Remove the protective tape from the instrument panel after installation.
  - Install the LH body side welt.
117. Install the glove box in the reverse order of removal.
- Connect the glove box light wire harness connector.

118. Install the RH instrument mask in the reverse order of removal.
- Remove the protective tape from the instrument panel after installation.
  - Install the RH body side welt.

119. Install the center console assembly in the reverse order of removal.
- Install the wire harness fixing clips.
  - Connect the wire harness connectors.

120. Install the center console rear finisher assembly in the reverse order or removal.

121. Install the electric shift selector in the reverse order of removal.
- Electric shift selector mounting bolt torque: 8.0 N•m (0.8 kg-m, **71 in-lb**)

**⚠ WARNING**

The electric shift selector contains a strong magnet. To avoid the risk of death or severe personal injury:

- People with an electro-medical apparatus should keep the electric shift selector away from their body. Otherwise, it may cause the electro-medial apparatus to malfunction.
- Keep the electric shift selector away from magnetic objects such as magnetic cards and metal items.
- Never subject the electric shift selector to impact by dropping or hitting it, water splash or high humidity.

122. Install the center console finisher assembly in the reverse order of removal.

123. Install the LH and RH instrument side panels in the reverse order of removal.

124. Remove the protective tape from the negative battery terminal, and then install the negative cable to the battery terminal.

- Negative battery cable terminal nut torque: 8.0 N•m (0.8 kg-m, **71 in-lb**)



## Check and Correct Any DTCs Set During Instrument Panel Removal

125. Turn the engine ON.

126. Connect the Vehicle Interface (VI) to the vehicle.

127. Start CONSULT-III plus (C-III plus) on the CONSULT PC.

- The serial number will display when the VI is recognized (Figure 133).

128. Select **Diagnosis (All Systems)**.

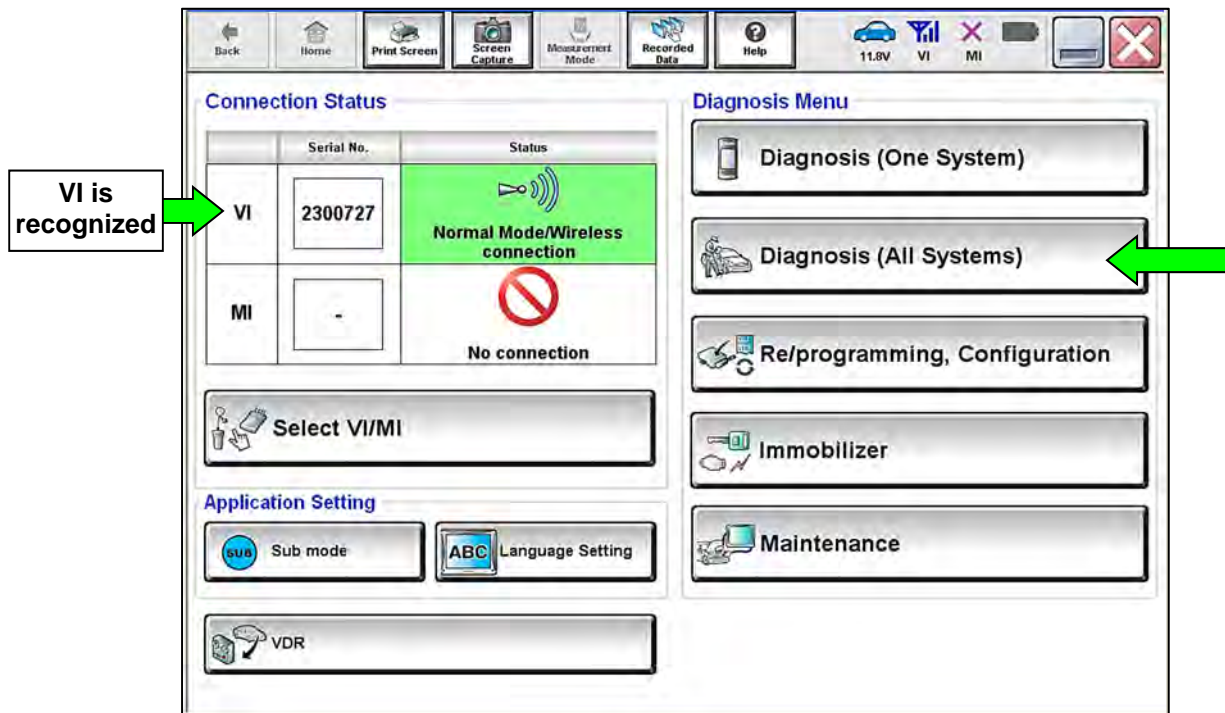

Figure 133

129. Select Automatic Selection(VIN).

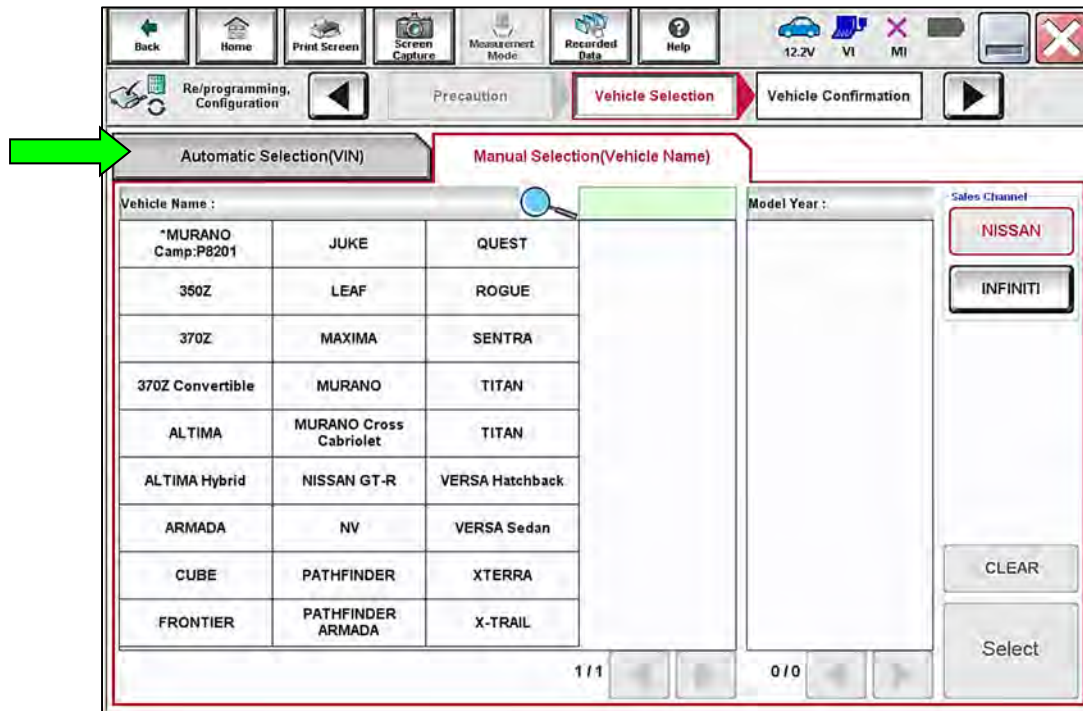

Figure 134

130. Confirm the VIN or Chassis # is correct, and then select Confirm.

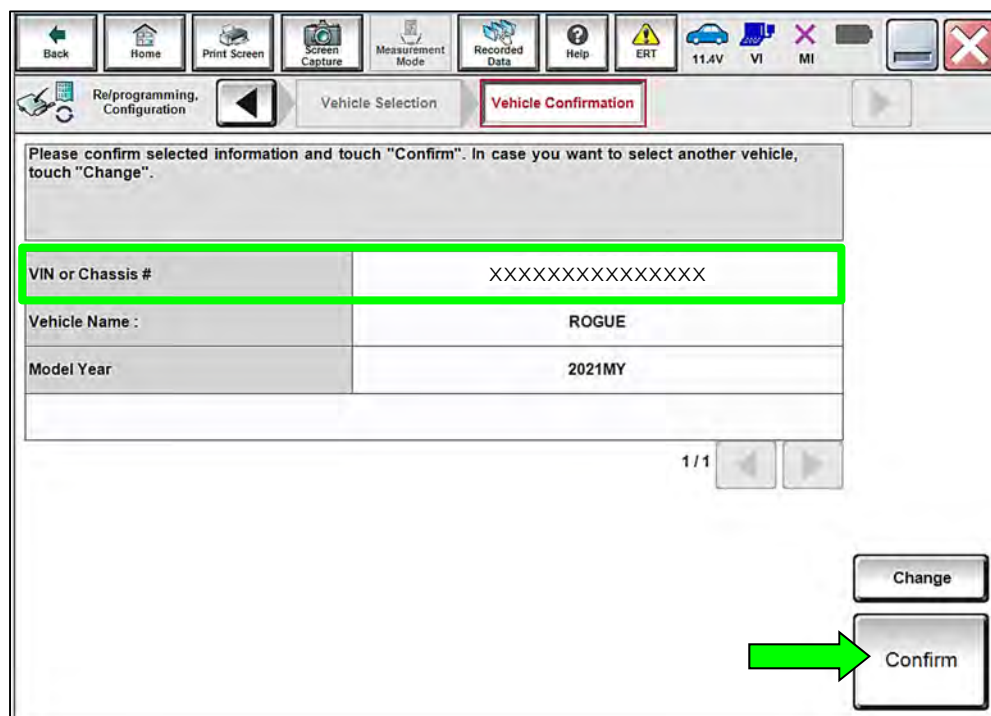

Figure 135

131. Confirm the VIN is correct for the vehicle, and then select **Confirm**.

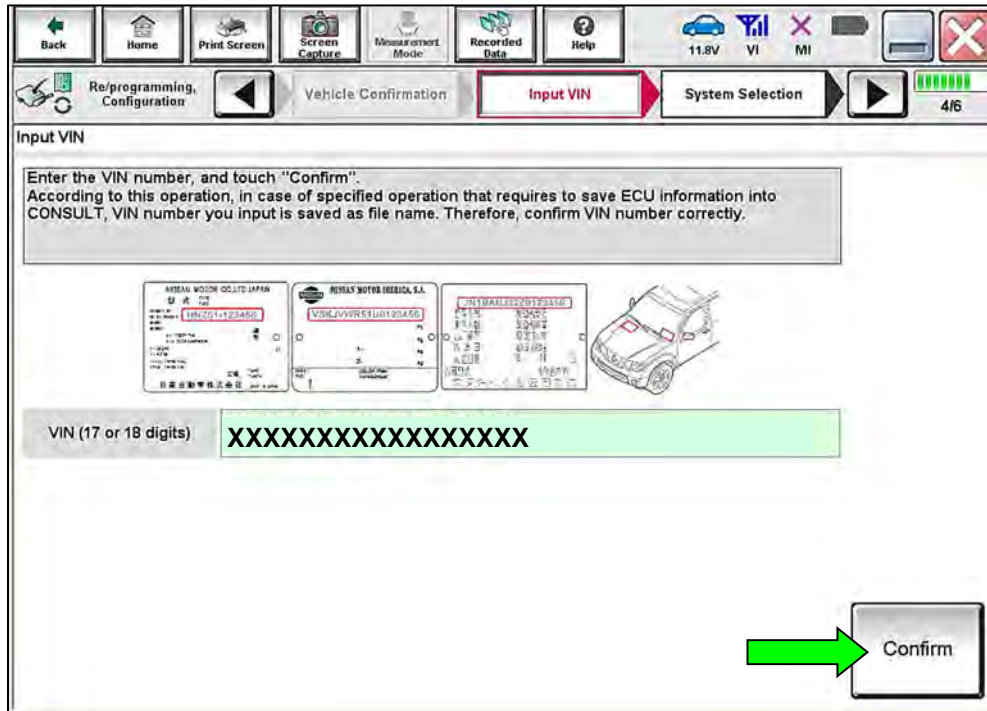

Figure 136

132. Check for DTCs.

- If any DTCs are present, correct the DTC before proceeding to step 133 on page 44.

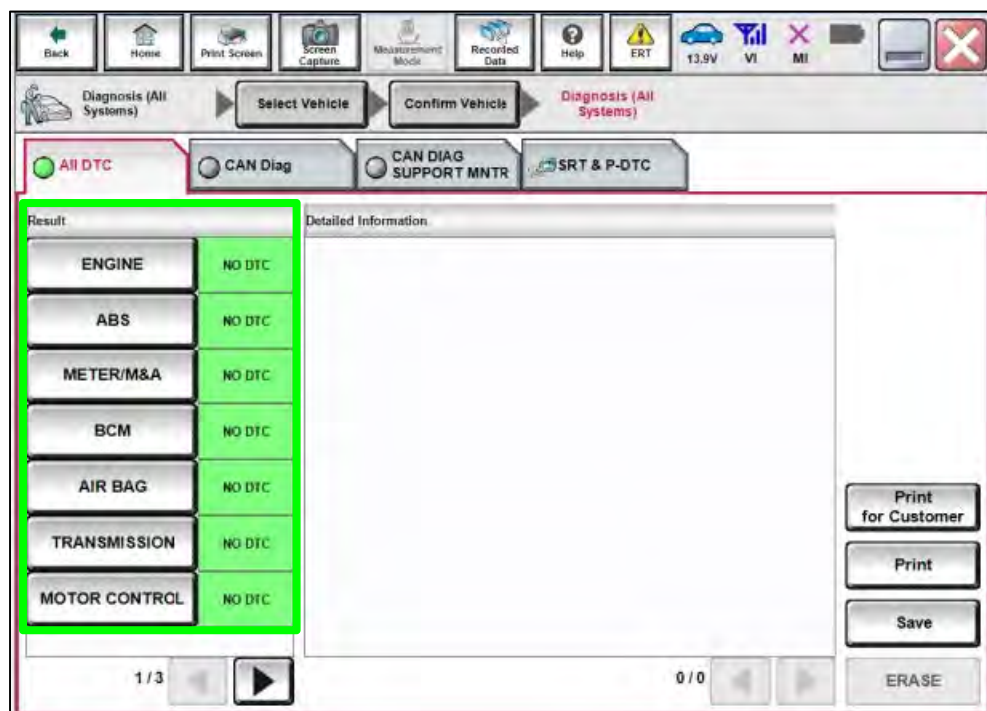

Figure 137

## Reprogram the Airbag Diagnosis Sensor Unit

**IMPORTANT:** Before starting, make sure:

- ASSIST on the CONSULT PC has been synchronized (updated) to the current date.
- All C-III plus software updates (if any) have been installed.

### NOTICE

- Connect a battery maintainer or smart charger set to reflash mode or a similar setting. If the vehicle battery voltage drops below 12.0V or rises above 15.5V during reprogramming, the Airbag Diagnosis Sensor Unit may be damaged.
- Be sure to turn OFF all vehicle electrical loads. If a vehicle electrical load remains ON, the Airbag Diagnosis Sensor Unit may be damaged.
- Be sure to connect the AC Adapter. If the CONSULT PC battery voltage drops during reprogramming, the process will be interrupted and the Airbag Diagnosis Sensor Unit may be damaged.
- Turn OFF all external Bluetooth® devices (e.g., cell phones, printers, etc.) within range of the CONSULT PC and the VI. If Bluetooth® signal waves are within range of the CONSULT PC or VI during reprogramming, reprogramming may be interrupted and the Airbag Diagnosis Sensor Unit may be damaged.

133. Select Home.

134. Select **Re/programming, Configuration.**

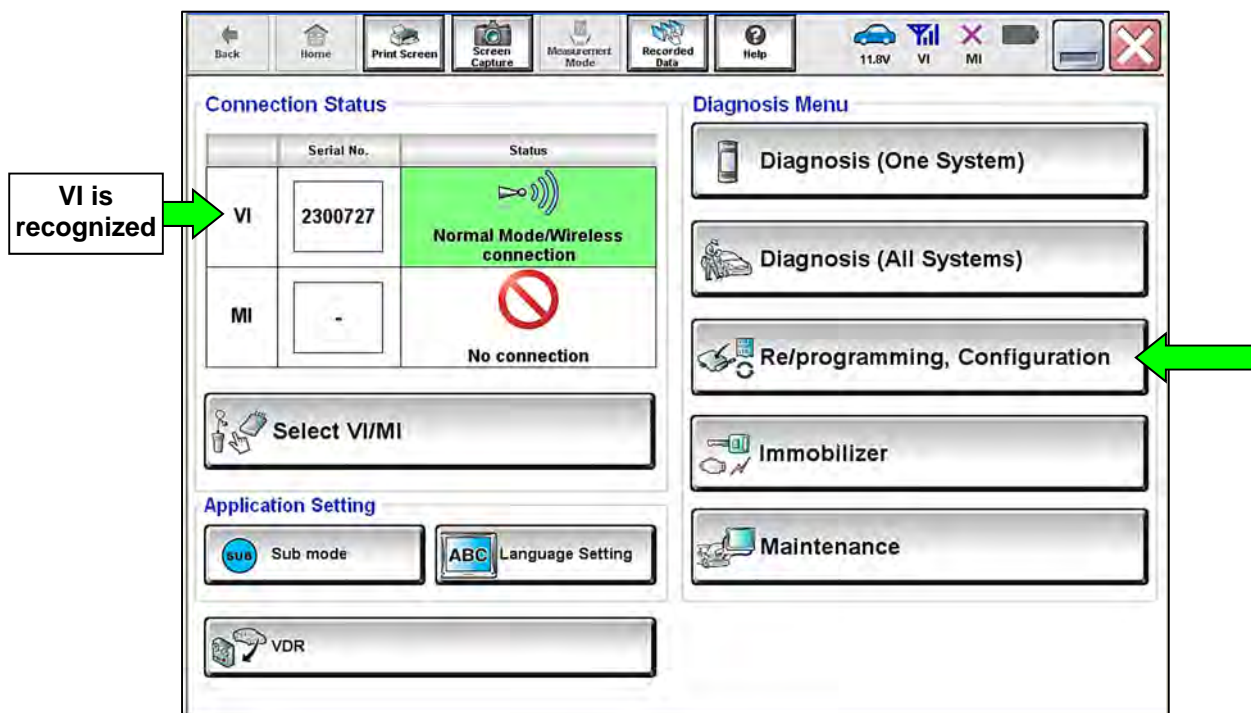

Figure 138

135. Check the box to confirm the precaution instructions have been read, and then select **Next**.

**NOTE:** Use the arrows (if needed) to view and read all precautions.

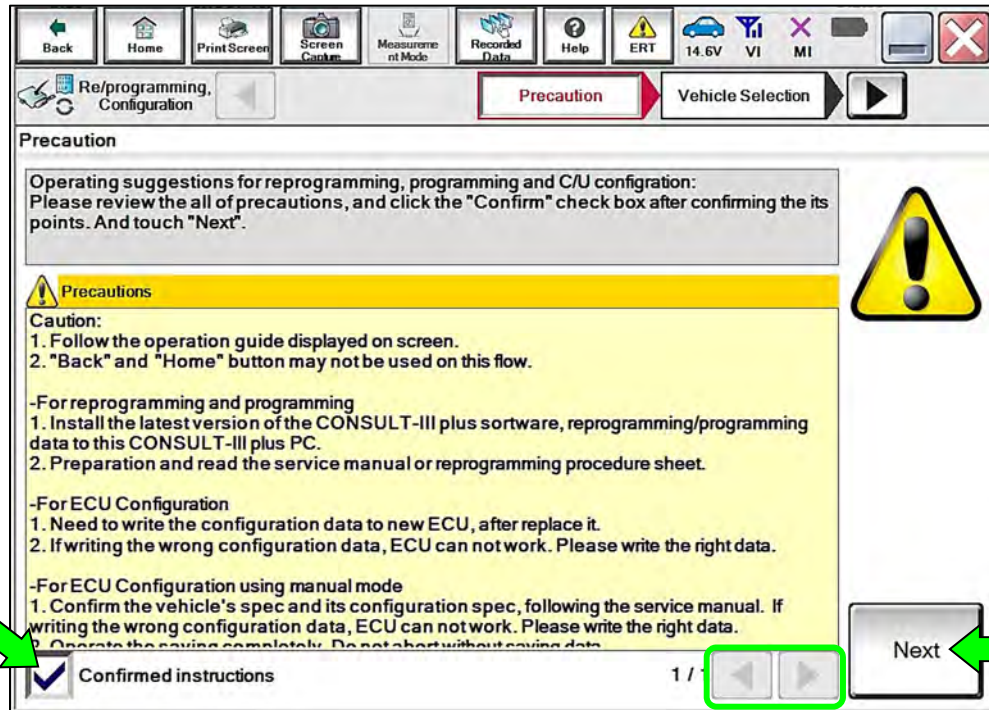

Figure 139

136. Select **Automatic Selection(VIN)**.

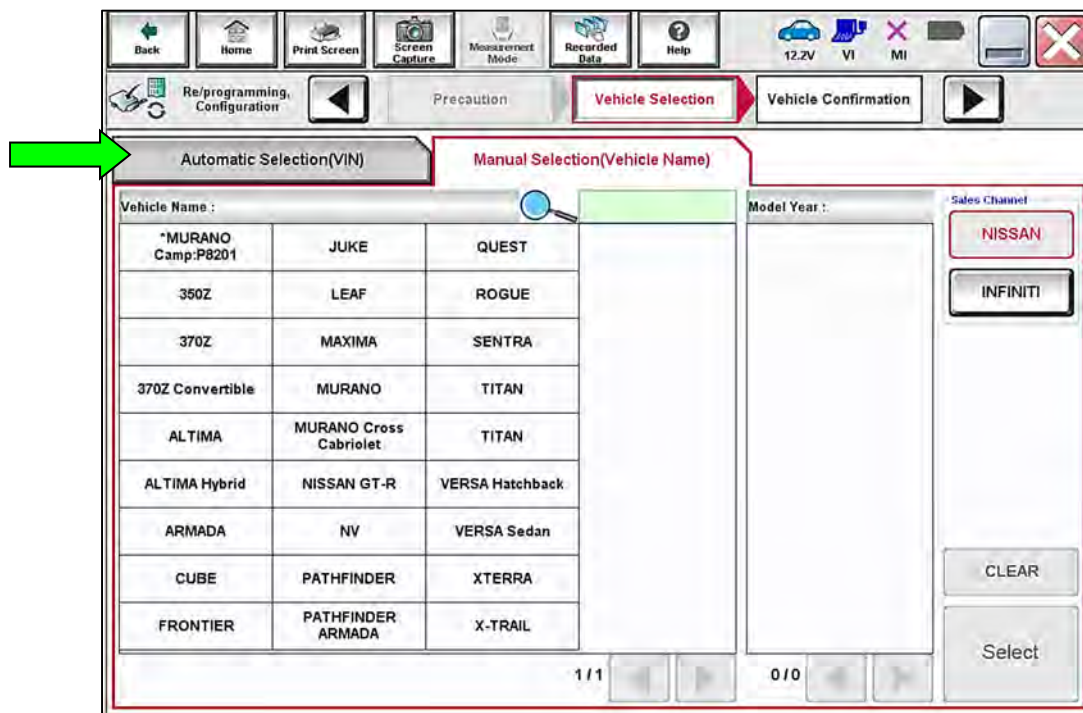

Figure 140

137. Confirm the **VIN or Chassis #** is correct, and then select **Confirm**.

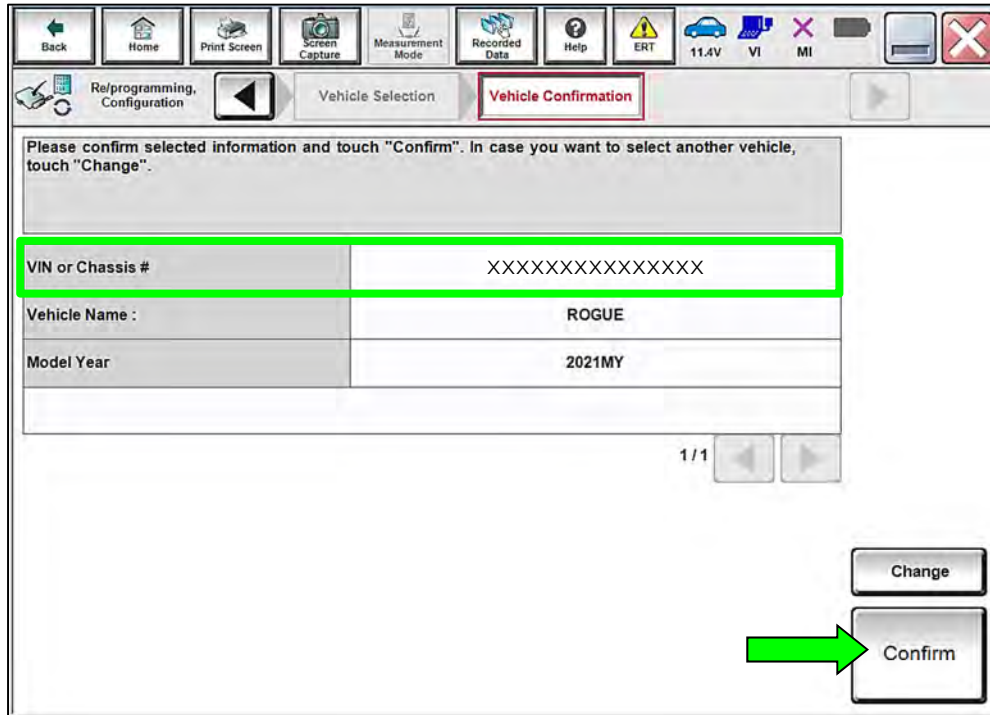

Figure 141

138. Confirm the VIN is correct for the vehicle, and then select **Confirm**.

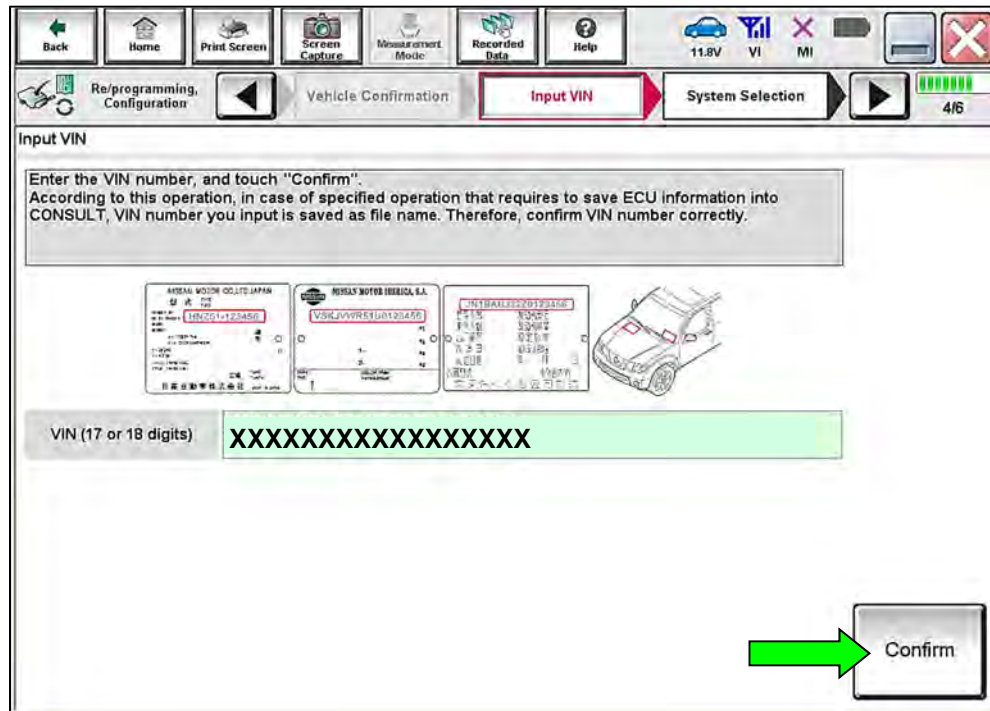

Figure 142

139. Select **AIR BAG**.

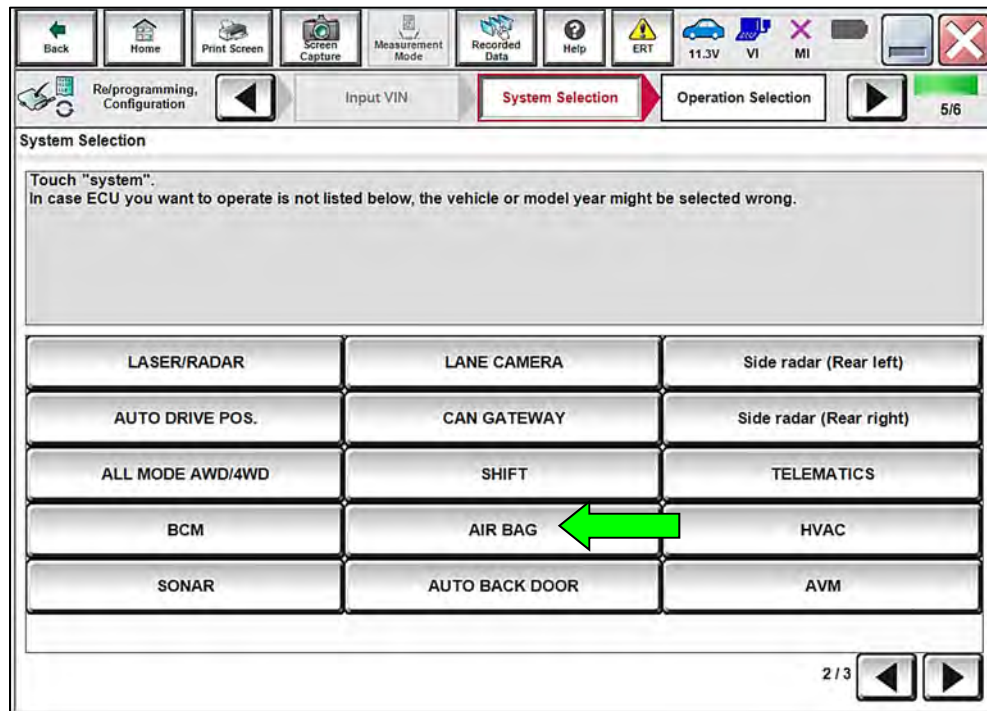

Figure 143

140. Select **Reprogramming**.

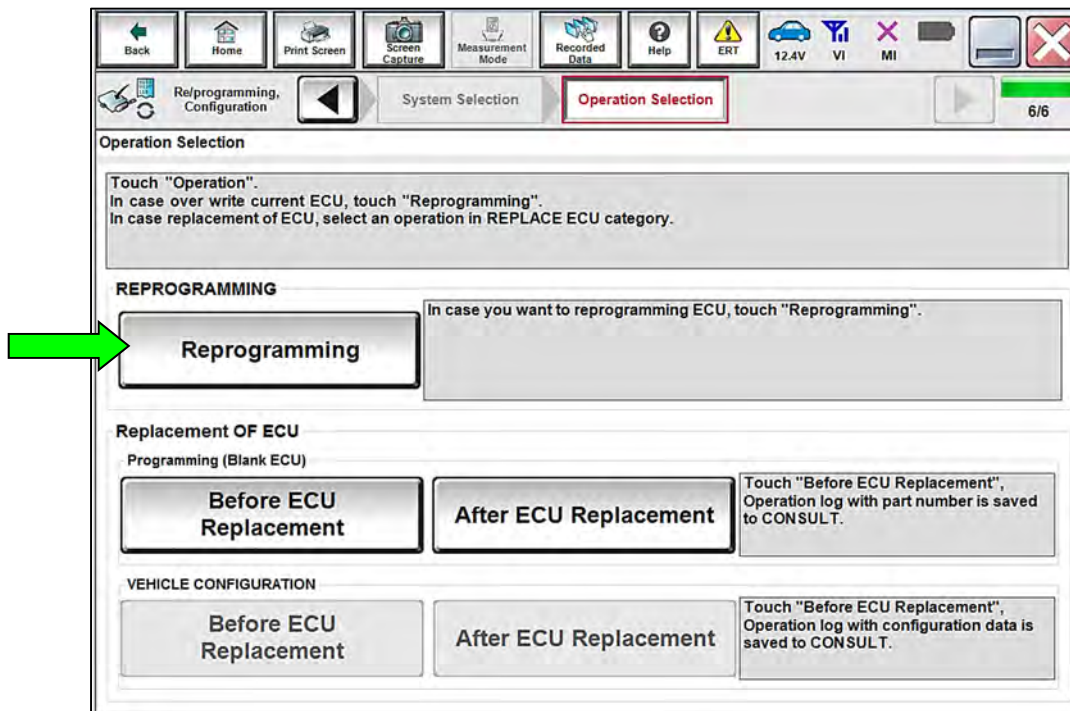

Figure 144

141. Find the Airbag Diagnosis Sensor Unit **Part Number** and write it on the repair order, and then select **Save**.

**NOTE:** This is the current Part Number (P/N).

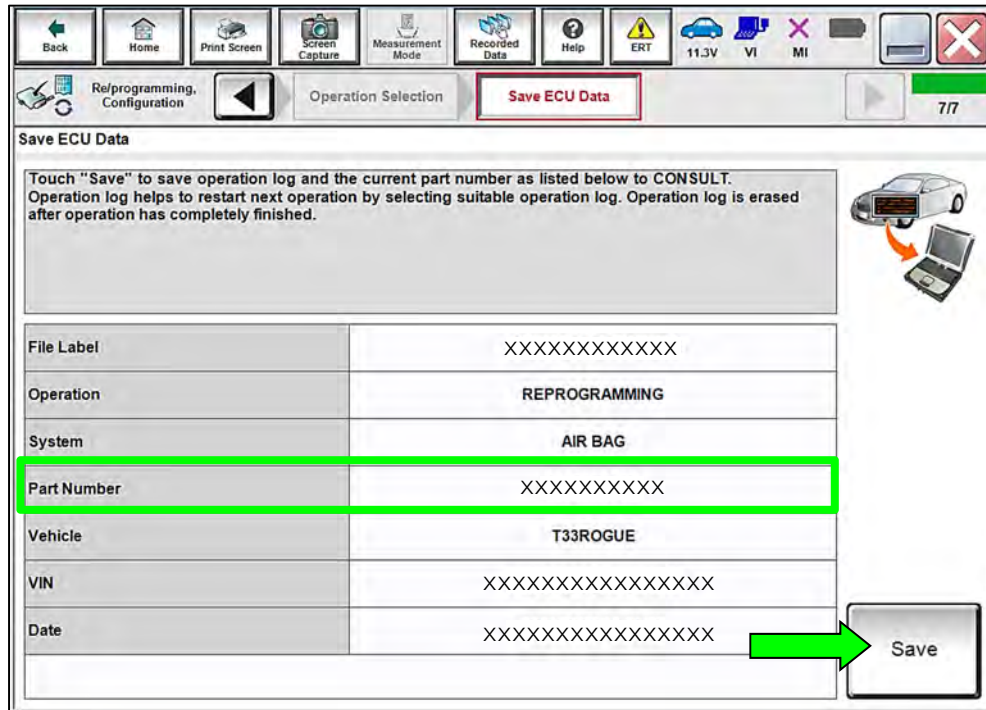

Figure 145

142. Check the box to confirm the precaution instructions have been read, and then select **Next**.

**NOTE:** Use the arrows (if needed) to view and read all precautions.

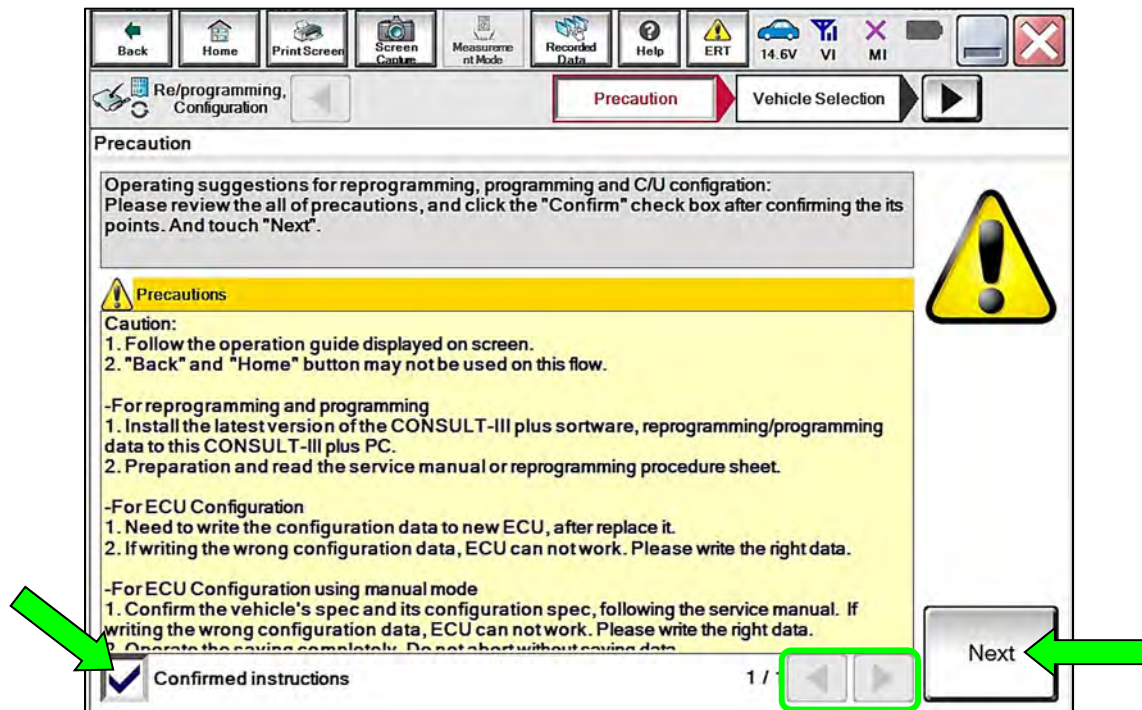

Figure 146



143. Verify that the **Current Part Number** and **Part Number After Repro/programming** are different, and then select **Next**.

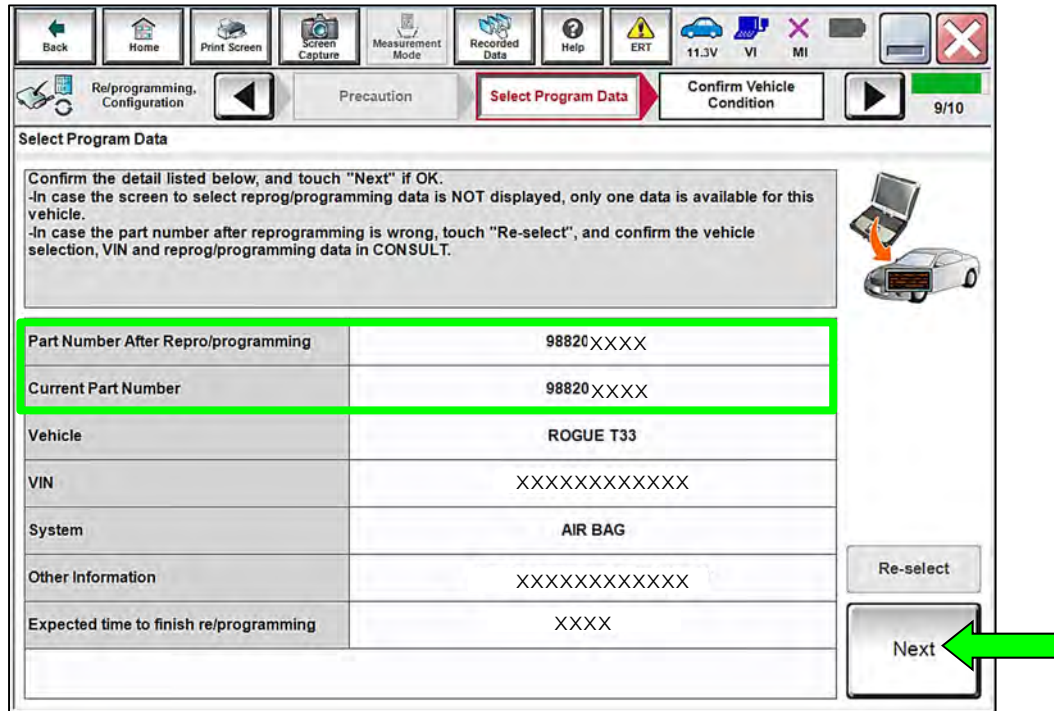

Figure 147

144. Confirm the battery charger is ON and the battery voltage is between 12V-15.5V, and then select **Next**.

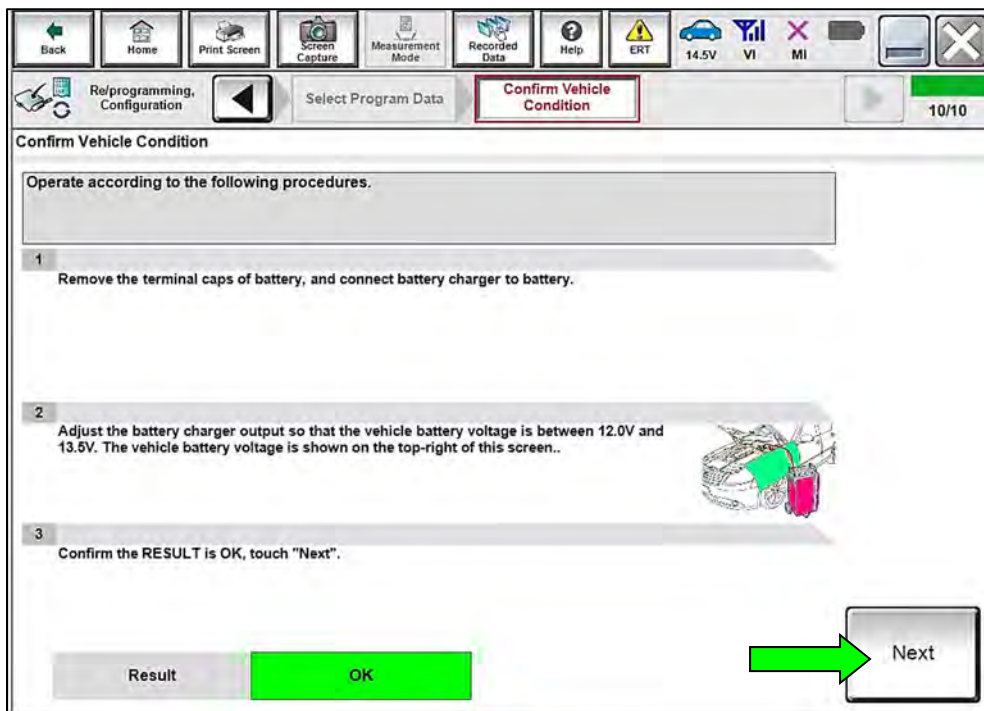

Figure 148

145. Confirm the **Judgement** for all the **Monitor Items** are “OK”, and then select **Start**.

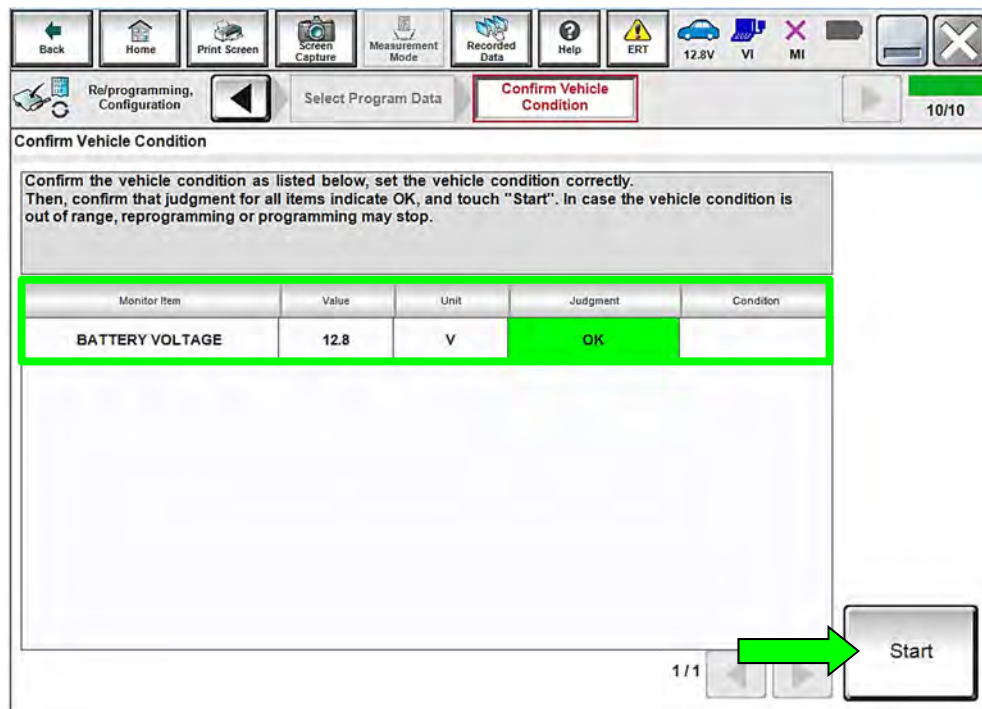

Figure 149

146. Select **USA/CANADA Dealers** from the drop down menu, and then select **OK**.

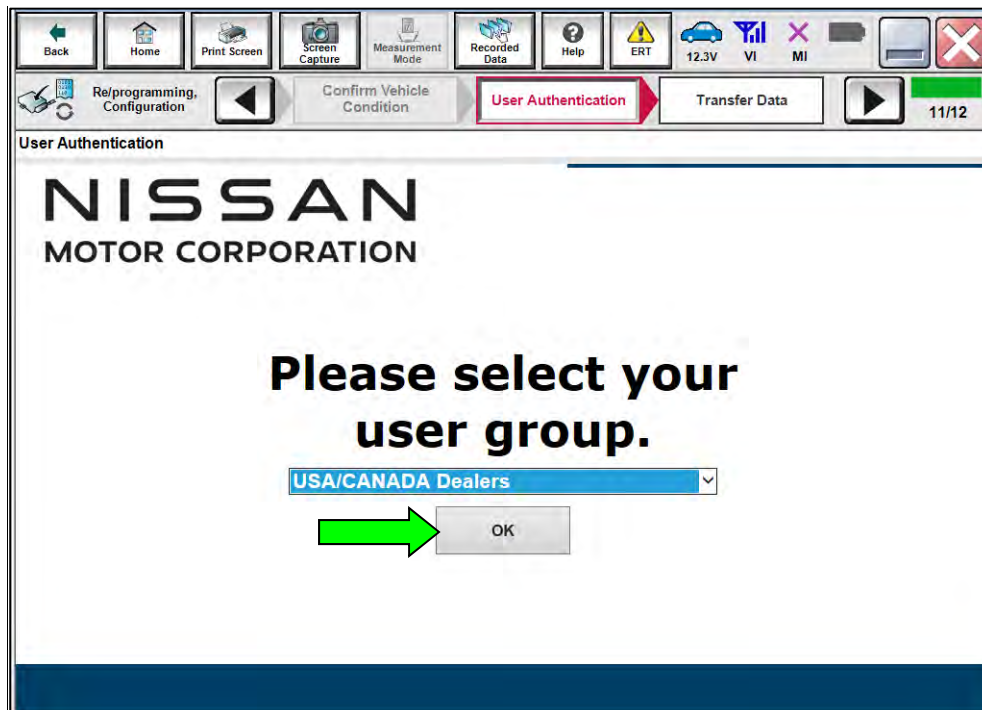

Figure 150

147. Login using your NNAnet credentials, and then select **Submit**.

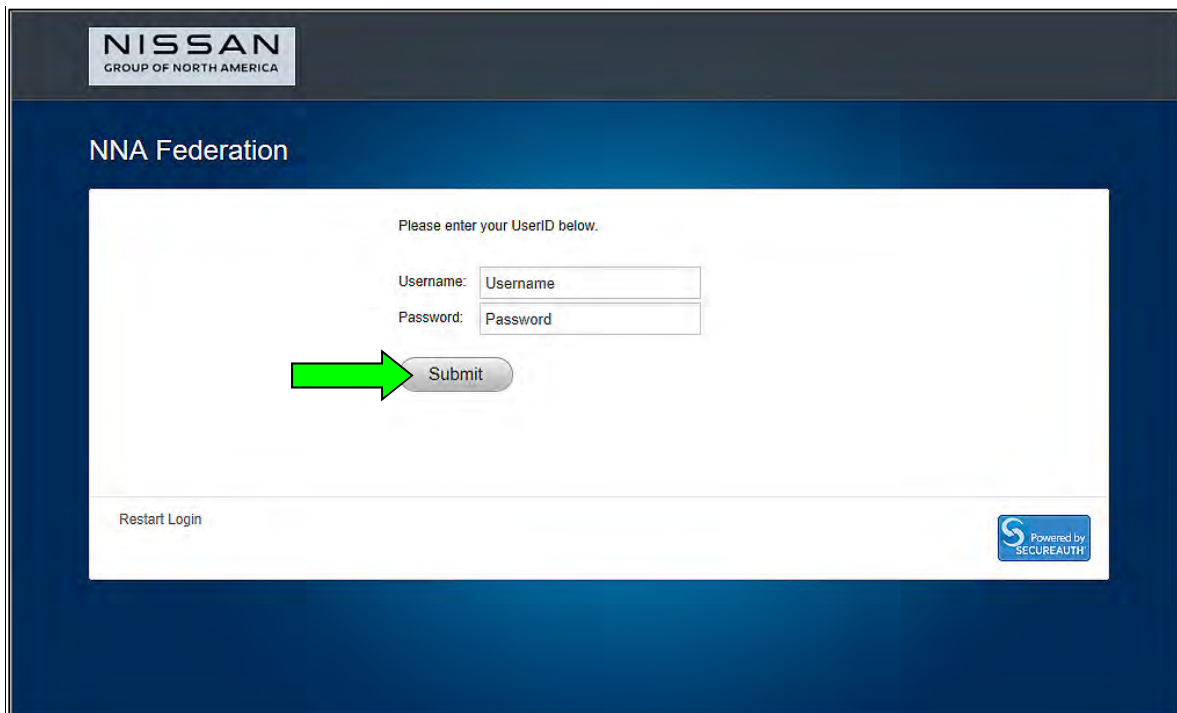

Figure 151

148. Allow **Transfer Data** to complete.

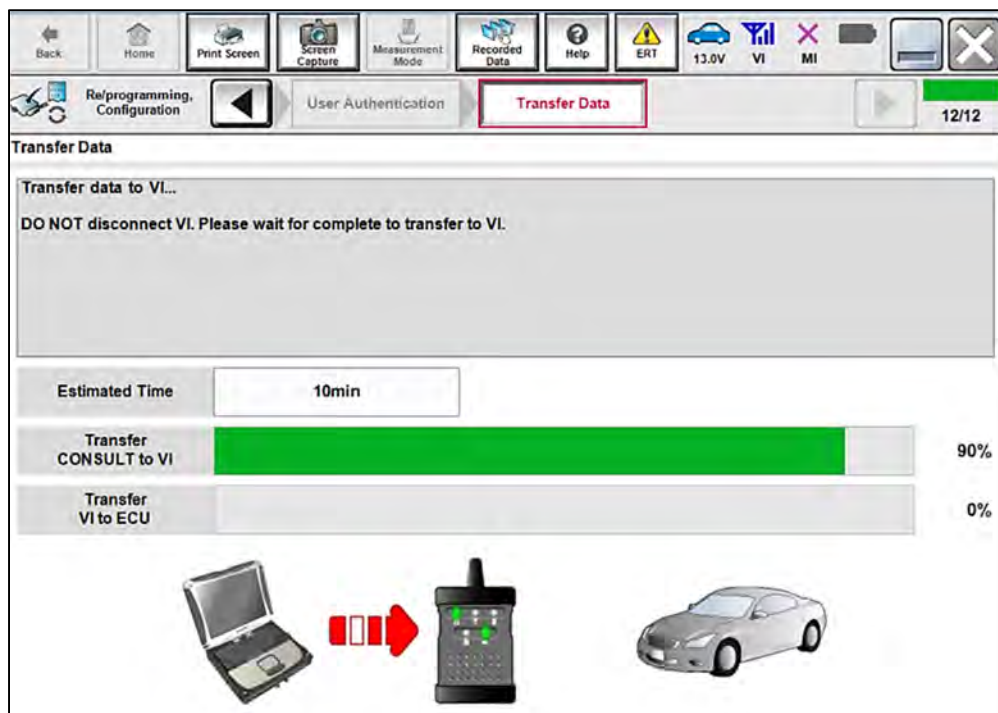

Figure 152

149. Once the reprogramming completes, select **Next**.

**NOTE:**

- If the screen in Figure 153 does not display (indicating that reprogramming did not complete), refer to the information on page 53.
- Additional steps/operations are required before CONSULT will provide the final reprogramming confirmation report. Continue with the reprogramming procedure on page 54.

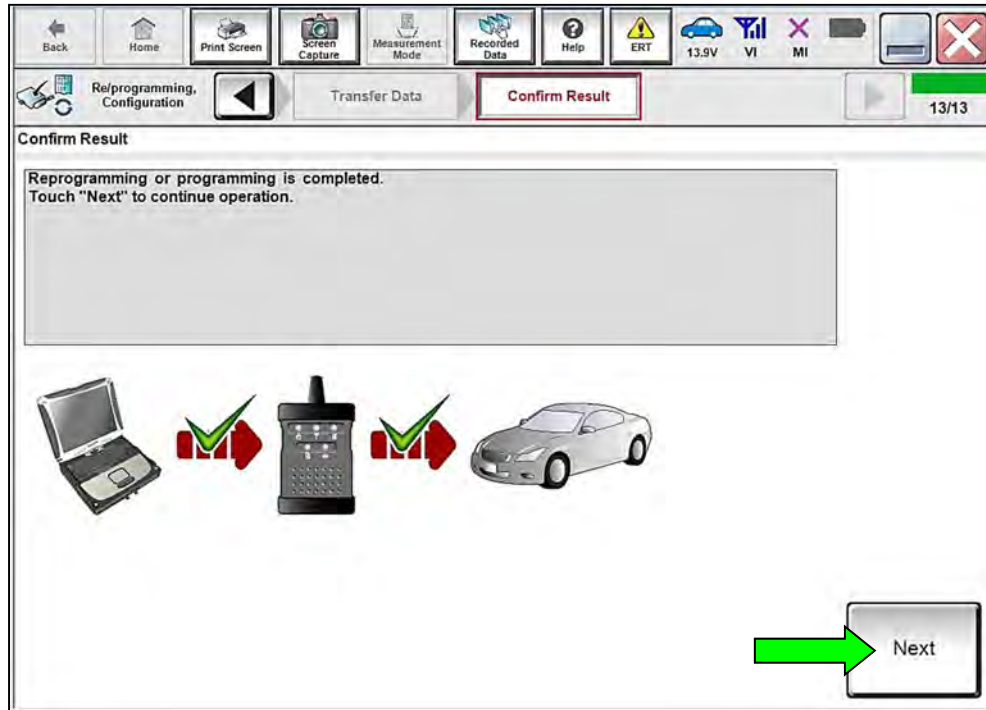

Figure 153

## Airbag Diagnosis Sensor Unit Recovery:

If reprogramming does not complete and the “!?” symbol displays as shown in Figure 154:

- Check battery voltage (12.0 – 15.5V).
- Ignition is ON, Engine is OFF.
- External Bluetooth® devices are OFF.
- All electrical loads are OFF.
- Select **Retry** and follow the on screen instructions.

**NOTE:** **Retry** may not go through on first attempt and can be selected more than once.

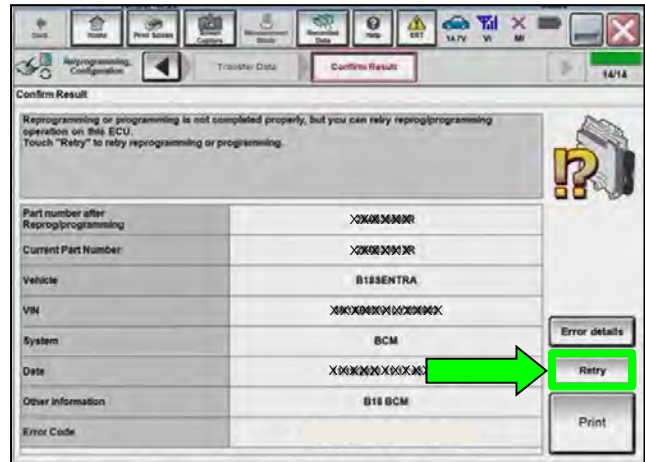

Figure 154

If reprogramming does not complete and the “X” symbol displays as shown in Figure 155:

- **Do not disconnect the VI or shut down C-III plus if reprogramming does not complete.**
- Check battery voltage (12.0 – 15.5V).
- CONSULT A/C adapter is plugged in.
- Ignition is ON, Engine is OFF.
- Transmission in Park.
- All C-III plus / VI cables are securely connected.
- All C-III plus updates are installed.
- Select **Home**, and then restart the reprogram procedure from the beginning.



Figure 155

150. Perform **Erase All DTCs**.

- a. Follow the on-screen instructions as shown in Figure 156 and Figure 157.

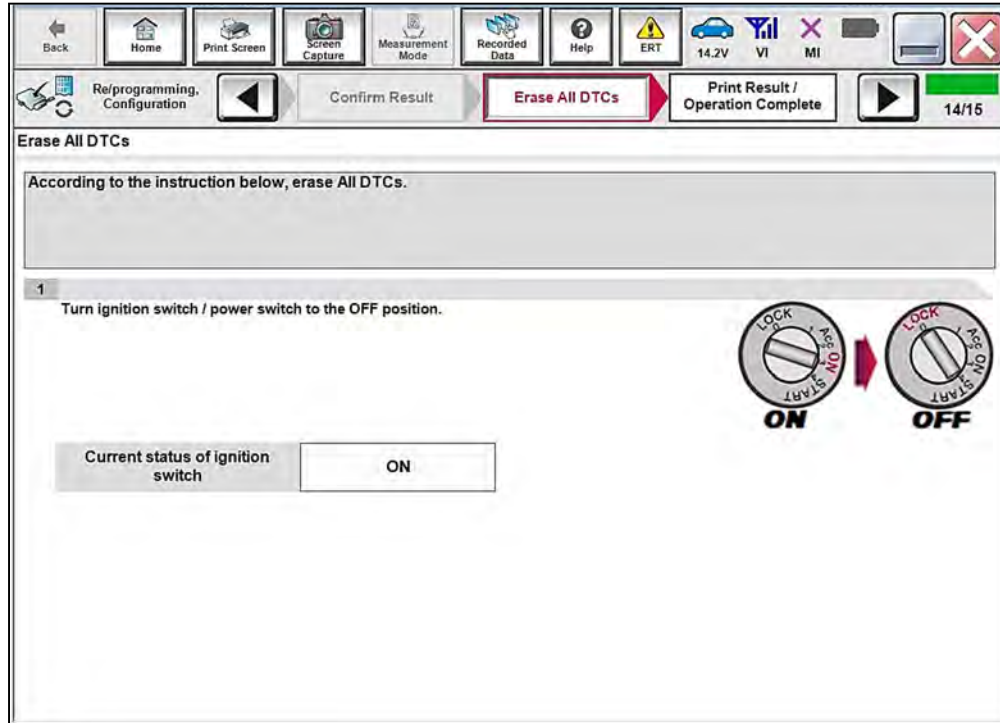

Figure 156

- b. Select **Next**.

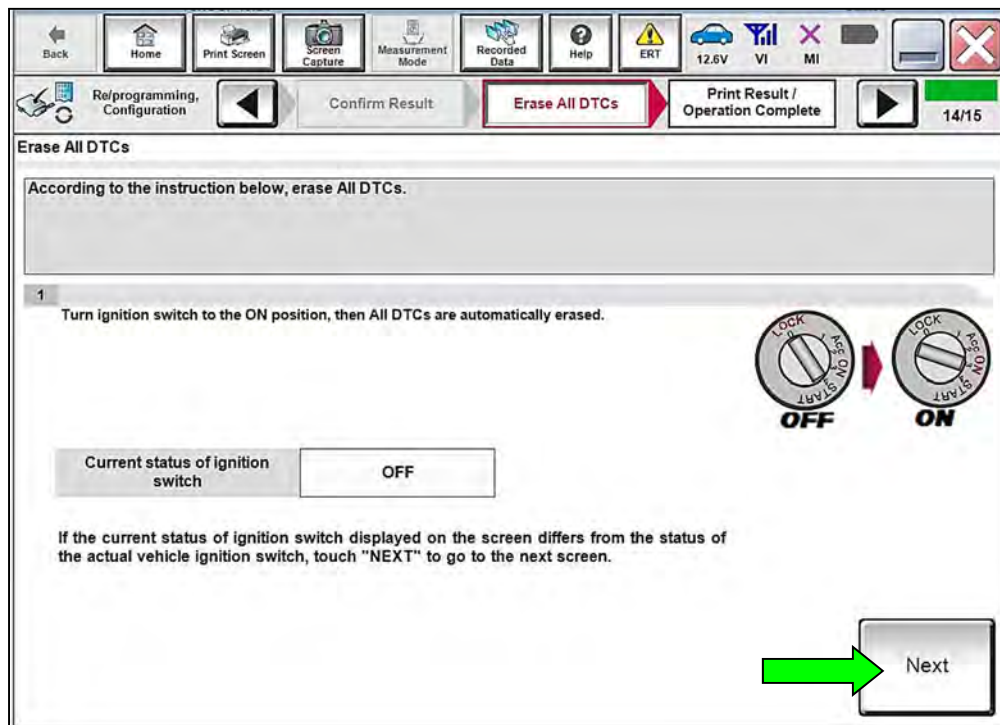

Figure 157

151. Allow **Erase All DTCs** to complete.

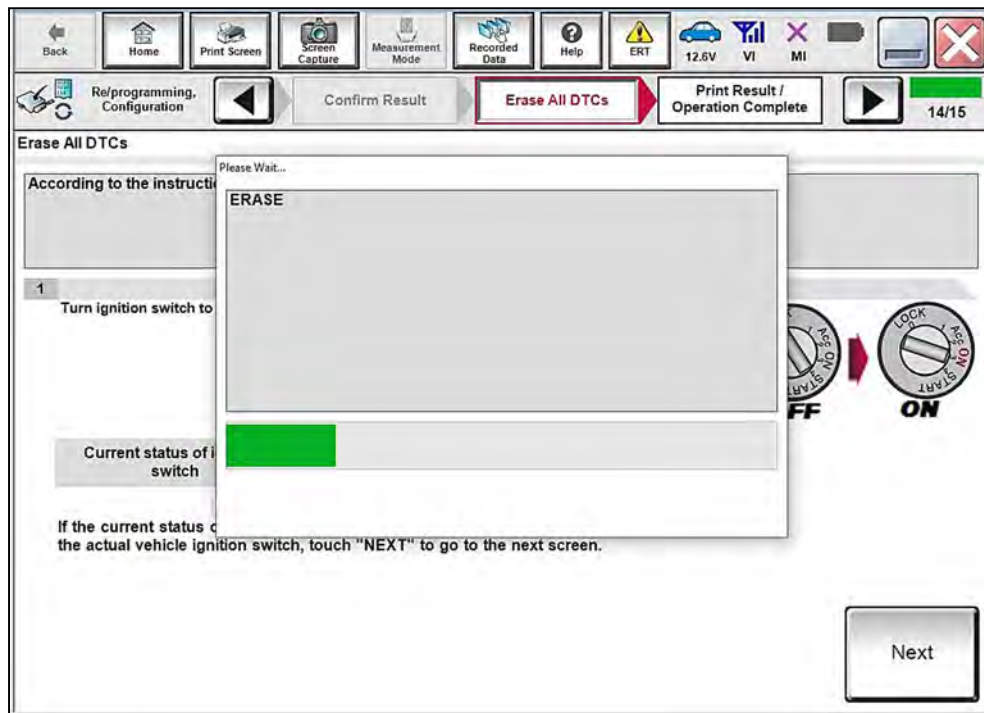

Figure 158

152. Select **Print** and attach the reprogramming results to the repair order, and then select **Confirm**.

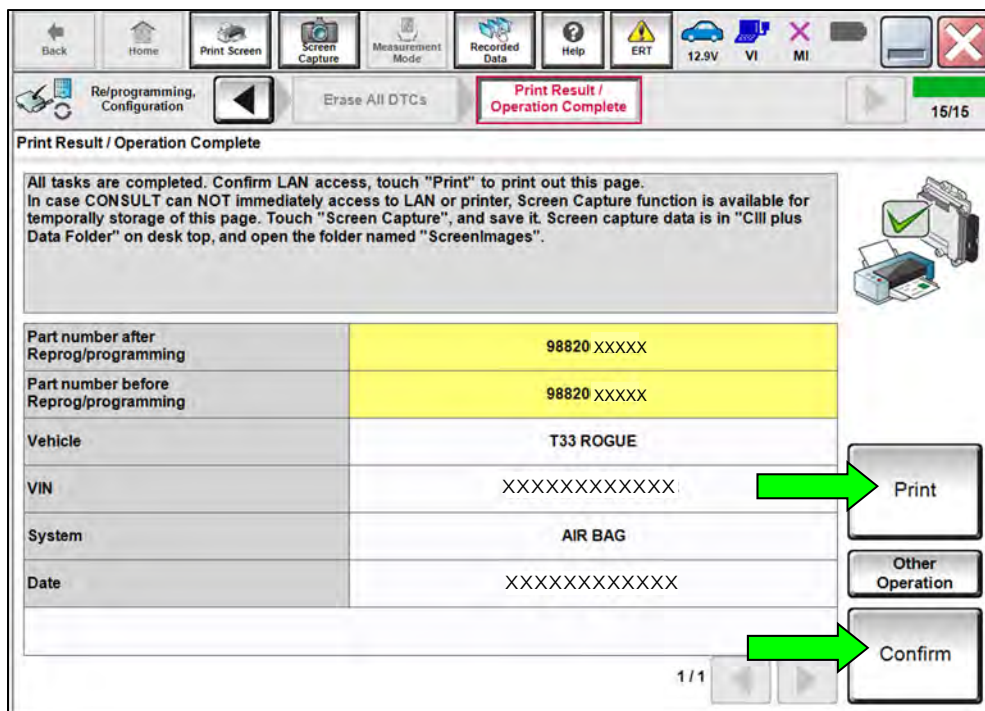

Figure 159

153. Select **Home**.

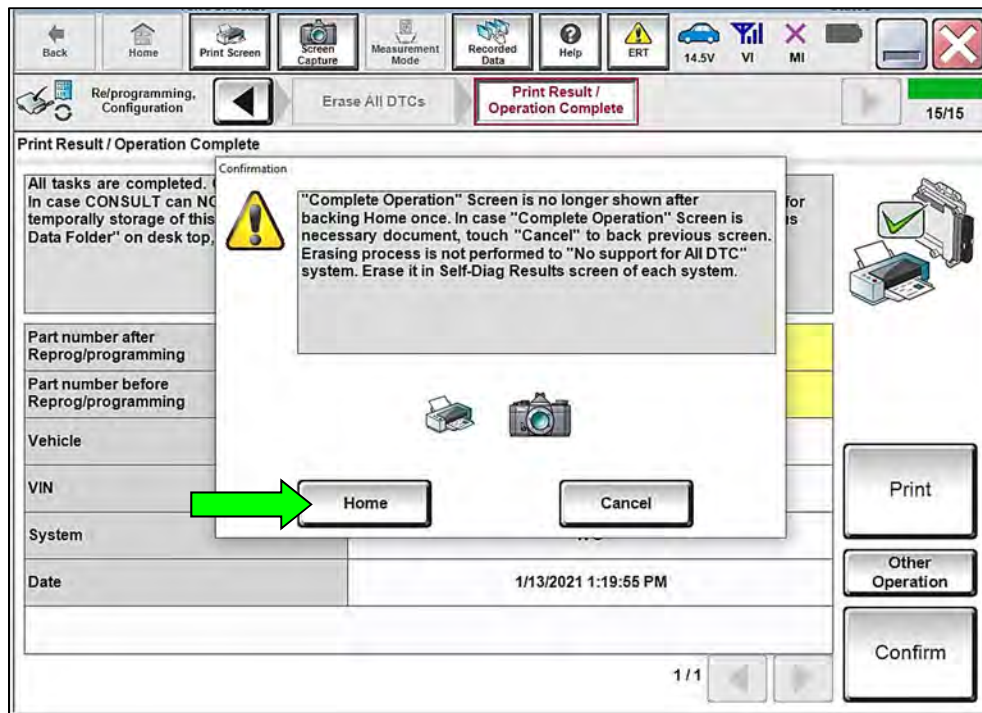

Figure 160

154. Remove the battery maintainer/smart charger.

155. Close the C-III plus application.

156. Remove the VI from the vehicle.

157. Perform **ADDITIONAL SERVICE WHEN REMOVING BATTERY NEGATIVE TERMINAL**.

- Refer to the ESM: **ELECTRICAL & POWER CONTROL > POWER SUPPLY, GROUND & CIRCUIT ELEMENTS > BASIC INSPECTION > INSPECTION AND ADJUSTMENT > ADDITIONAL SERVICE WHEN REMOVING BATTERY NEGATIVE TERMINAL**



## PARTS INFORMATION

DESCRIPTION	PART NUMBER	QUANTITY
MODULE ASSY – AIR BAG, ASSIST	K8E15-6RC0A	1
BELT ASSY – TONGUE, PRETENSIONER CHARCOAL (G) AND TAN (C) INTERIOR TRIM	H6884-6RR7A	1
BELT ASSY – TONGUE, PRETENSIONER GRAY (K) INTERIOR TRIM	H6884-6RR7B	
CLIP (A-Pillar Trim Anchor Clips)	76988-6LB5A	2
BOLT (Driver Knee Airbag Bolt)	01125-N6061	2

## CLAIMS INFORMATION

Submit a “CM” line claim using the following claims coding:

CAMPAIGN (“CM”) ID	DESCRIPTION	OP CODE	FRT
P2A08	Replace Front Passenger Seat Belt Retractor Assembly, Airbag Module, and Reprogram The Airbag Diagnosis Sensor Unit	P2A080	3.9

## AMENDMENT HISTORY

PUBLISHED DATE	REFERENCE	DESCRIPTION
July 25, 2022	NTB22-063	Original bulletin published
July 28, 2022	NTB22-063A	<b>PARTS INFORMATION</b> revised
August 8, 2022	NTB22-063B	<b>APPLIED DATES</b> and <b>APPLIED VINS</b> removed, and <b>INTRODUCTION</b> revised