



Service Bulletin

Bulletin No.: 20-NA-198

Date: August, 2022

TECHNICAL

Subject: Trailer Running Lights Shut Off Due to Excessive Load on the Running Lamp Circuit

Brand:	Model:	Model Year:		Date Breakpoint:		Engine:	Transmission:
		from	to	from	to		
Chevrolet	Silverado 1500 (New Model)	2019	2019			All	All
	Silverado 1500	2020	2020				
	Silverado 2500HD/3500HD						
GMC	Sierra 1500 (New Model)	2019	2019				
	Sierra 1500	2020	2020				
	Sierra 2500HD/3500HD						

Involved Region or Country	North America, Middle East, Argentina (Mercosur), Brazil (Mercosur), Bolivia (West), Chile (West), Colombia (West), Ecuador (West), Paraguay (West), Peru (West), Uruguay (West), GM Korea Company, Singapore, Phiippines, Egypt, Other Africa, South Africa.
Additional Options (RPOs)	Equipped with INDICATOR-TRAILER INFORMATION (U1D)
Condition	Some customers may comment that the running lamps may illuminate for a second or two, and then go out when operating a trailer running lamp circuit with more than 7-8 amps of current draw. On vehicles with LED lighting, the owner may have concerns with a flash of the lighting about once every 10 seconds.
Cause	The cause of the condition may be that trailers with incandescent running lamps may have in-rush current that exceeds the trailer lighting module limits for current flow. And that monitoring voltage may illuminate LED lights even when trailer theft deterrent is not enabled.
Additional Information	<p>On 2019 Model Year vehicles, equipped with U1D, use the K68 Trailer Lighting Control Module to control all trailer lighting through pulse width modulated (PWM) voltage. The Trailer Lamp Control Module has a current handling capability on the running lamp circuit of about 9 amps. On a trailer with a large number of incandescent lights, in-rush current can exceed 20 amps before it settles back to around 8-9 amps. During this inrush or "marriage" current period, the Trailer Lamp Control Module may see the inrush current as an "overload" and go into protection mode.</p> <p>On 2020 Model Year vehicles, there may be complaints about either trailers that cannot be properly detected, or complaints about light flash related to trailer connection monitoring on trailers with LED lighting.</p> <p>Install a 2021 design module and re-pin the running lamps to pin 25 for the running lamps. (2019 model year only). This requires a terminated lead to be inserted into cavity 25 on the chassis harness X1 connector. Wiring connected to pin 5 on the X1 will be cut and reconnected to Pin 25. Terminal in cavity 5 will remain, be blunt cut, and sealed with a closed end duraseal splice to prevent water entering through pin 5.</p> <p>This also changes the trailer connection detection flashing of LED lighting from every 10 seconds to every 42 minutes. (Connection detection will still be enabled if trailer theft deterrent is enabled).</p>

Correction

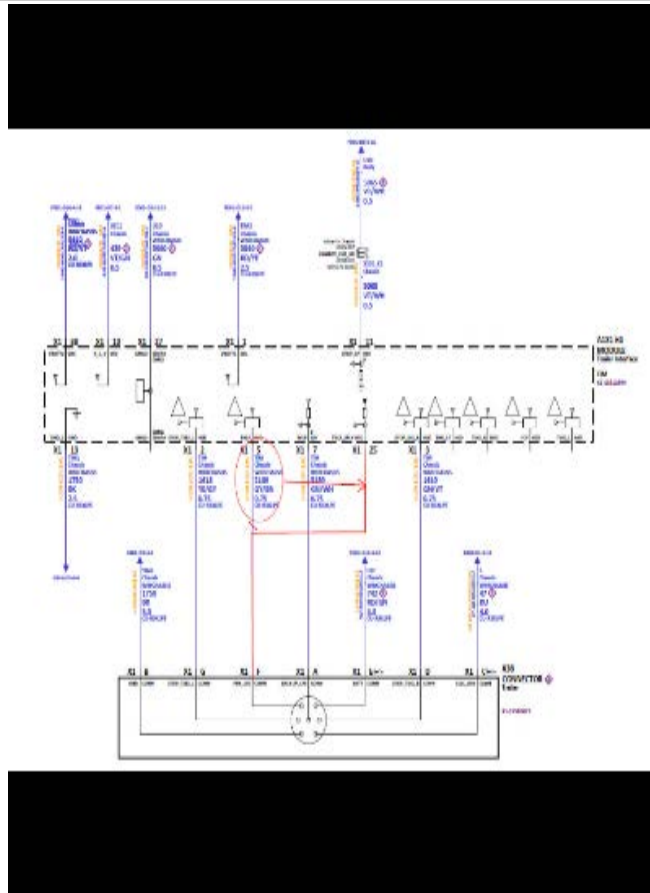

5652571

For 2019 models ONLY, Follow the steps in the Service Procedure below, and move circuit 2109 on the Trailer Lamp Control Module from X1 cavity 5 to X1 cavity 25, and install new Trailer Lighting Module GM P/N 13540274.

For 2020 models ONLY, No wiring changes are required. Change the Trailer Lighting Control Module to GM P/N 13540274.

Service Procedure

Important: Important: Service agents must comply with all International, Federal, State, Provincial, and/or Local laws applicable to the activities it performs under this bulletin, including but not limited to handling, deploying, preparing, classifying, packaging, marking, labeling, and shipping dangerous goods. In the event of a conflict between the procedures set forth in this bulletin and the laws that apply to your dealership, you must follow those applicable laws.

Important: If both trailer tail lamp codes are present on a 2019 Model vehicle, please review to make sure the re-pinning service procedure has been fully performed. If the replacement Trailer Lighting Module is installed on a 2019 vehicle without doing the wiring service

procedure, DTC B3885-04 Trailer Left Tail Lamp Circuit and DTC B3886-04 Right Trailer Tail Lamp Circuit will set when a trailer is connected.

- **For 2019 models ONLY**, the complete Service Procedure must be completed.
- **For 2020 models ONLY**, jump ahead to step #14 and install the new Trailer Lamp Control Module.

1. Raise and support the vehicle. Refer to *Lifting and Jacking the Vehicle* in SI.
2. Lower and reposition the spare tire, if necessary.

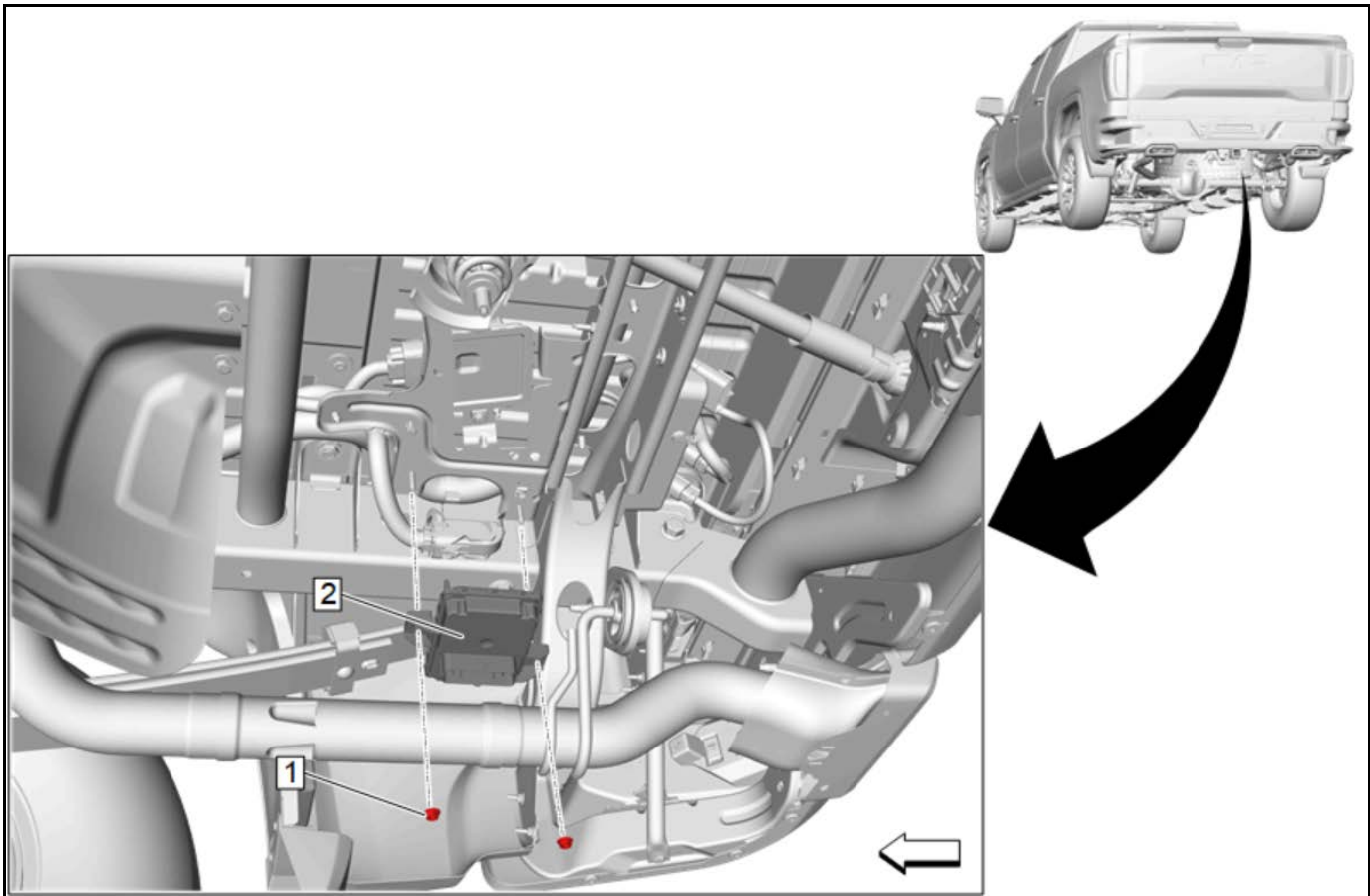

5209978

3. Locate the Trailer Lamp Control Module (2) and disconnect the chassis harness X1 electrical connector.

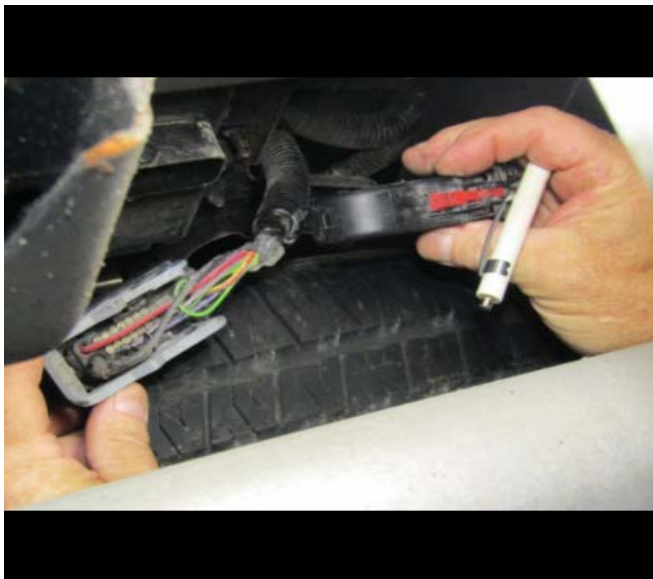

5652572

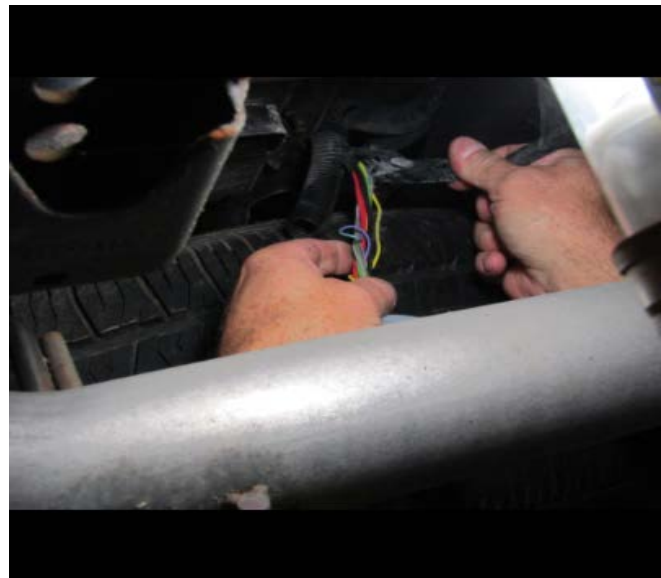

5652574

4. Cut off the tie strap retaining the wiring harness and remove the cover from the connector.

5. Pull the wiring harness out of protective sleeve, and trim back previous tape to access the wiring.

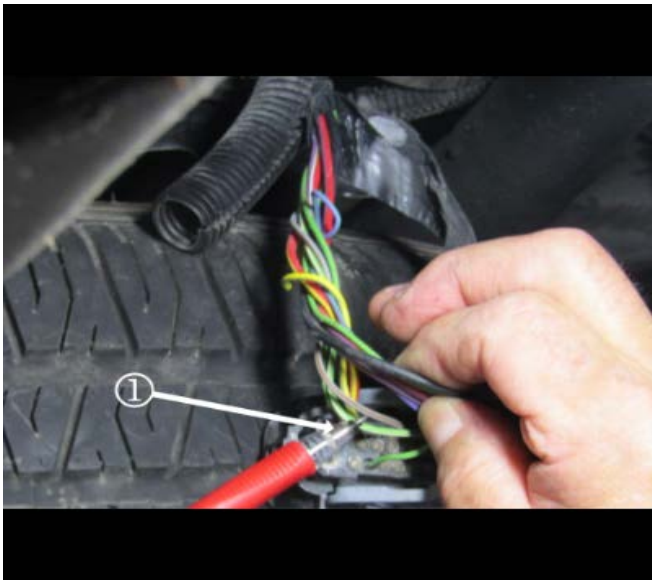

5652575



5652578

7. Release the 4 tabs on the Terminal Position Assurance (TPA) and pull slightly upward to partially release it from the connector housing.

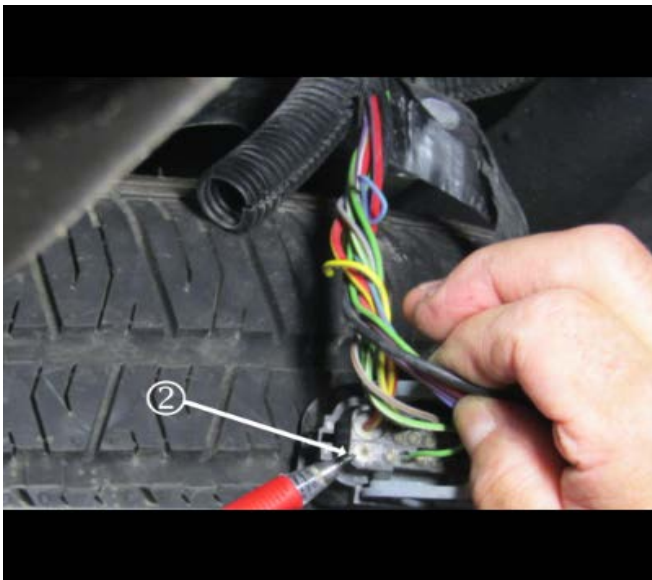

5652576

6. Locate the Gray/Brown wire, at pointer (1), connected to cavity 5, and cut the wire approximately 7.62 cm (3.0 in) from the connector body. The wire will be re-located to cavity 25 (2).

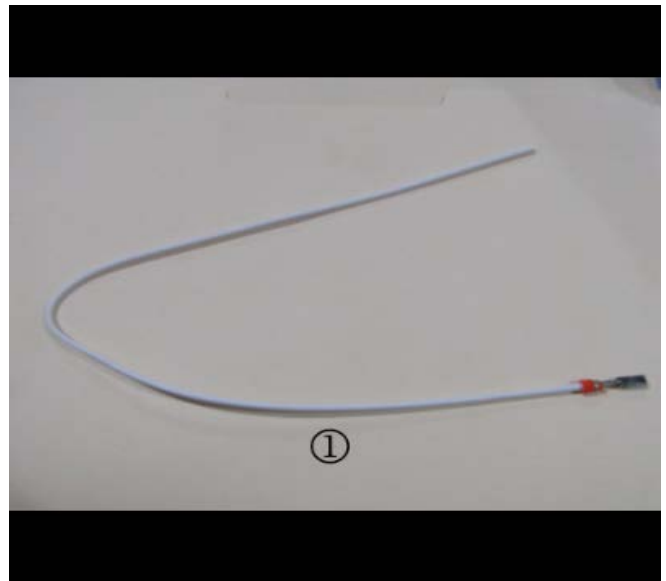

5662018

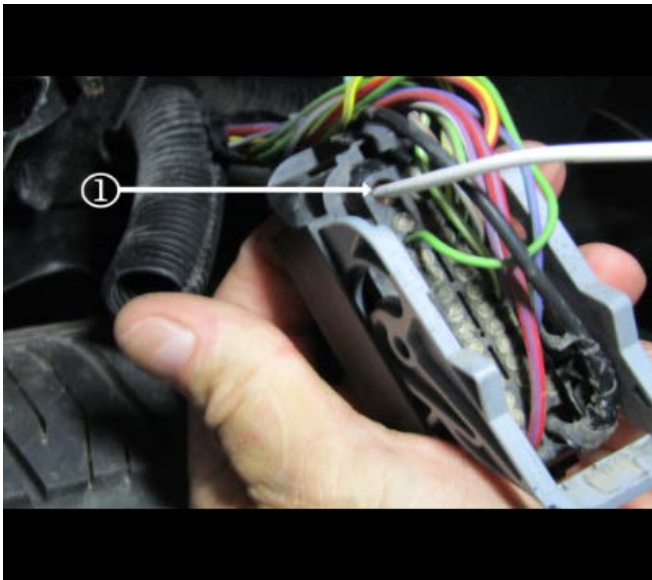

5652580

8. Remove the seal from connector cavity 25 and install the new terminated lead (1) into this cavity. Ensure the terminal locks into place by pulling back gently on the wire.



5652578

9. Gently press down on the TPA until all 4 tabs re-engage with the connector and are fully seated.



5662021

10. Crimp a salmon Duraseal splice sleeve onto the striped end of the wire stub in cavity 5 of the connector. Attach the harness side of the grey brown wire to the end of the terminated lead that was just installed into cavity 25, using another salmon duraseal splice sleeve.

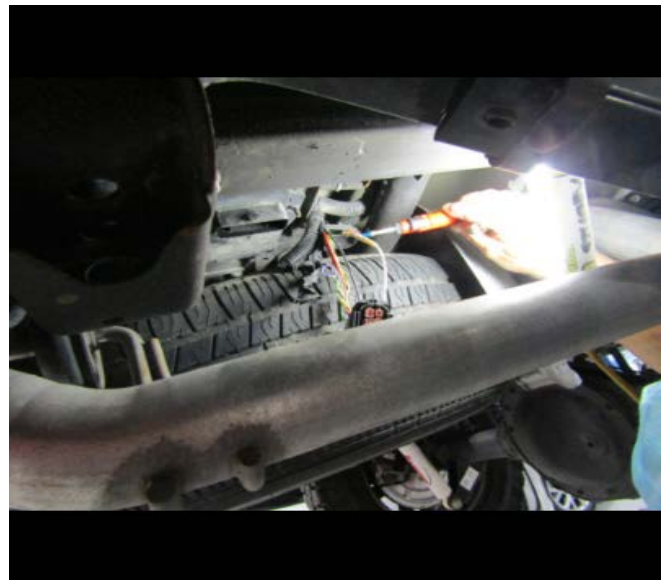

5662022

11. Use the Ultra torch to shrink the splice sleeve around the wire and also seal the open end. Use the Ultra torch to shrink the splice sleeve around the grey/brown and white terminated lead wires. Refer to the Weatherpack™ Wiring Repair section of *Wire to Wire Repair*. in SI.



5652583

12. Using Woven Polyester (PET) Electrical/ Anti-Abrasive Tape, or equivalent, re-tape the harness where the previous tape was removed and reposition the harness back inside the sleeve.

13. Reinstall the connector cover. Replace the tie strap that was removed previously.
14. Install the new trailer lamp control module. Refer to *Trailer Lamp Control Module Replacement*, in SI.
15. Reconnect the connector.
16. Remove the support and lower the vehicle.

Parts Information

Causal Part	Description	Part Number	Qty
N/A	WIRE,SPLICE (TERMINATED LEAD)	13575368	1
	MODULE ASM-TRLR LP CONT	13540274	1
	SPLICE,WIRE (SALMON)	19300089	2

Warranty Information

For vehicles repaired under the Bumper-to-Bumper coverage (Canada Base Warranty coverage), use the following labor operation. Reference the Applicable Warranties section of Investigate Vehicle History (IVH) for coverage information.

Labor Operation	Description	Labor Time
5480858*	New Trailer Lamp Control Module Replacement	0.3 hr
Add	Move Circuit 2109 on the Trailer Lamp Control Module (2019 Models Only)	0.7 hr

*This is a unique Labor Operation for Bulletin use only.

Version	6
Modified	<p>Released September 28, 2020</p> <p>Revised October 23, 2020 – Revised Text in Several Procedure Steps to Better Clarify Repair, Added Graphic, Updated Parts Information</p> <p>Revised December 04, 2020 – Added 2020 Model Year and Updated Labor Operation with Add.</p> <p>Revised January 29, 2021 – Revised Service Procedure to Note it is Necessary to Contact TCSC For Repair of 2019 Model Year Vehicles Only. It is Not necessary to Contact TCSC for 2020 Model Year Repairs.</p> <p>Revised April 07, 2021 – Updated Service Procedure for Trailer Lamp Control Module Replacement, Updated Parts and Warranty Information.</p> <p>Revised August 09, 20220 – Added a First Important to Service Procedure and Added a Lead Sentence to the Second Important.</p>

