



INFINITI

TECHNICAL SERVICE BULLETIN

Classification: BT22-009	Reference: ITB22-023	Date: May 11, 2022
-----------------------------	-------------------------	-----------------------

KNOCK NOISE OVER BUMPS FROM SECOND ROW SEATS

APPLIED VEHICLES: 2022 QX60 (L51)
APPLIED DATES: Built on or before January 28, 2022
APPLIED SEATS: Second Row Captain Seats and 60/40 Bench Seats

IF YOU CONFIRM

A knocking and/or rattling noise is heard in one, or both, second row seat(s), when driving over uneven or rough road surfaces.

ACTION

Perform the **SERVICE PROCEDURE**, starting on page 2, to install two (2) plastic washers into each seat.

NOTE: This procedure will be applied to both the incident seat, as well as the remaining second row seat.

IMPORTANT: The purpose of **ACTION** (above) is to give you a quick idea of the work you will be performing. You **MUST** closely follow the entire **SERVICE PROCEDURE** as it contains information that is essential to successfully completing this repair.

Bulletins are intended for use by qualified technicians, not 'do-it-yourselfers'. Qualified technicians are properly trained individuals who have the equipment, tools, safety instruction, and know-how to do a job properly and safely. **NOTE:** If you believe that a described condition may apply to a particular vehicle, **DO NOT** assume that it does. See your Infiniti retailer to determine if this applies to your vehicle.

SERVICE PROCEDURE

The following steps will be applied to all four (4) second row rear seat front pivots; two (2) on the driver (LH) side and two (2) on the passenger (RH) side.

Figure 1 is of a passenger side Captain Seat and its two (2) seat front pivots. The driver side Captain Seat and 60/40 bench seats are similar.

1. Slide both front seats all the way forward, and then both rear seats all the way back, to access the second row rear seat's front pivots.

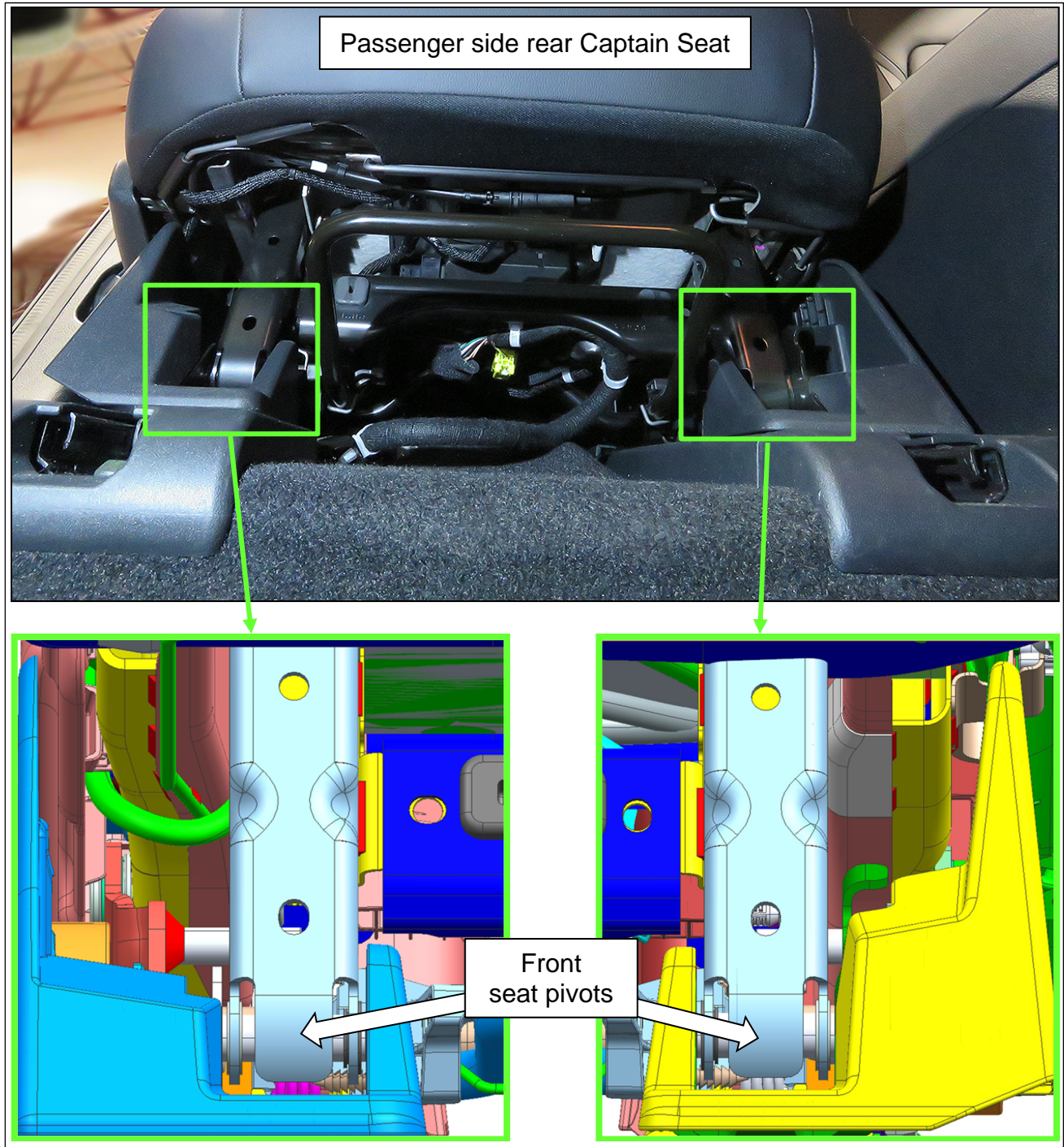

Figure 1

- Using an appropriate tool that will not damage the painted surfaces, insert the tool between the outside of the seat frame front pivot assembly and the seat slide, where shown in Figure 3.

HINT: A small pry bar with the end wrapped with tape can be used.

- Figure 3 is of a passenger side Captain Seat inner seat pivot assembly.



Figure 2

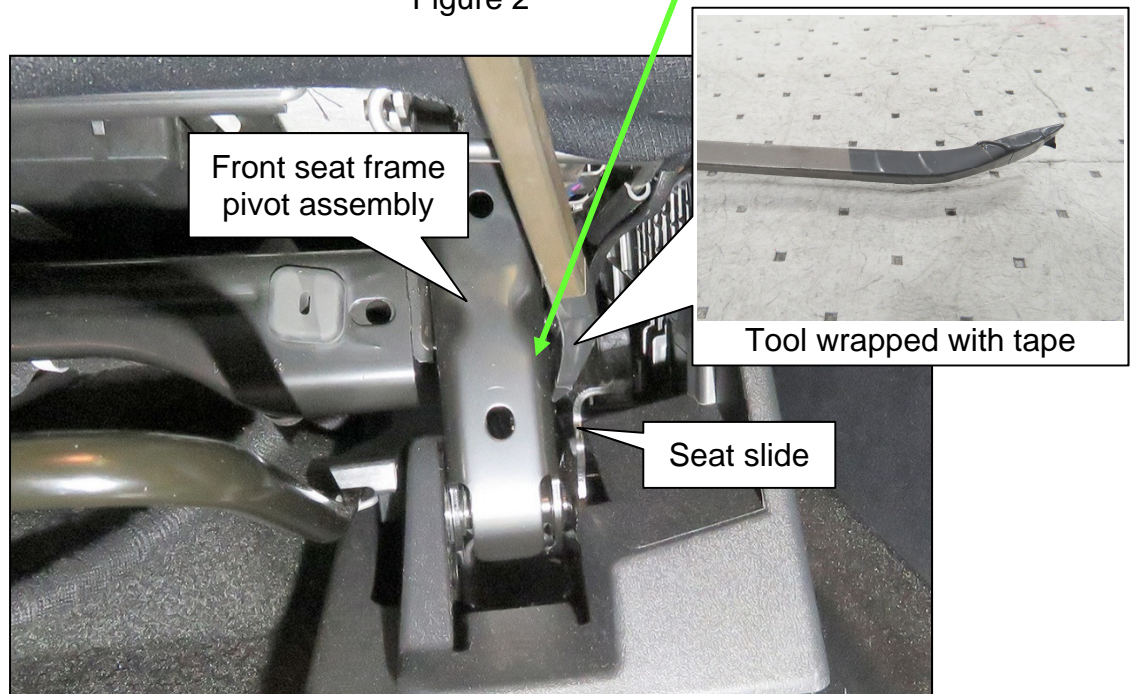
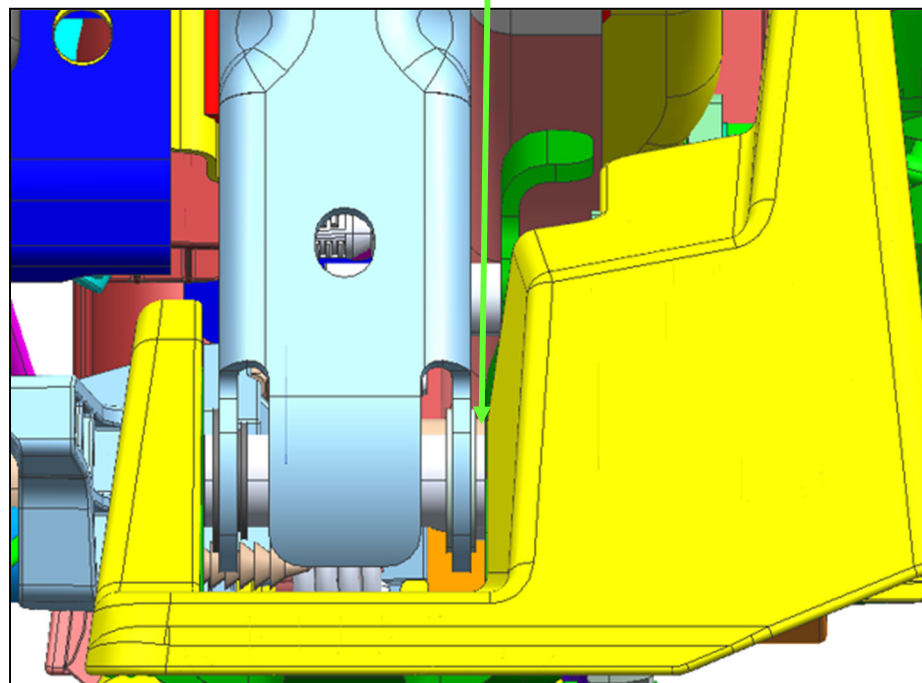
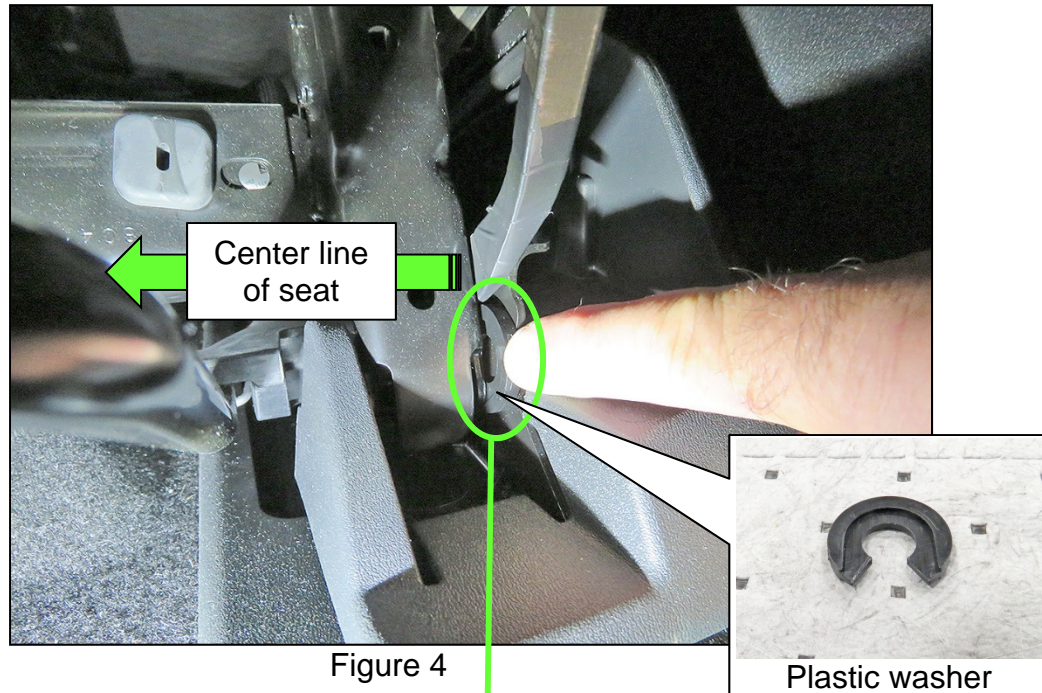

Figure 3

3. While gently prying the seat frame pivot assembly toward the seat's center line, insert one (1) plastic washer, as shown in Figure 4.
 - Pry to the left (passenger side) for a right side seat pivot assembly.



4. Push the plastic washer onto the seat pivot until it snaps into place.
 - A blunt ended tool may be used to apply enough pressure to the plastic washer to snap it into place.

5. Move to the opposite seat pivot and gently pry the seat frame pivot assembly toward the seat's center line, and then insert one (1) plastic washer.
 - Pry to the right (driver side) for a left hand seat pivot assembly.



Figure 6

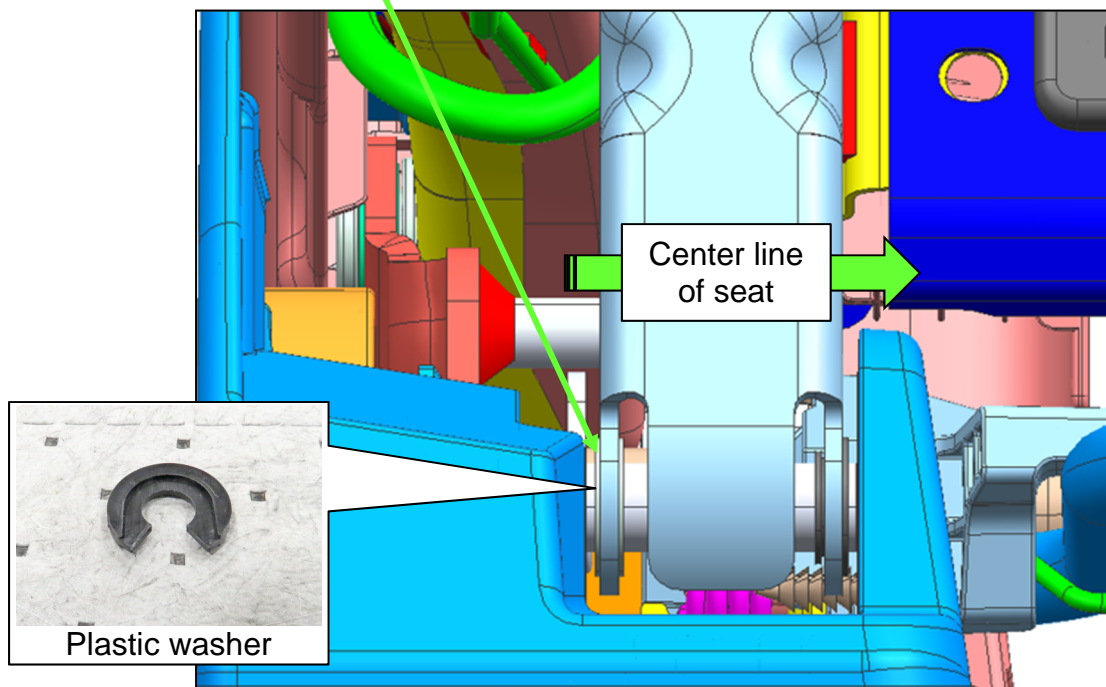

Figure 7

6. Push the plastic washer onto the seat pivot until it snaps into place.
 - A blunt ended tool may be used to apply enough pressure to the plastic washer to snap it into place.
7. Perform steps 2-6, starting on page 3, to install the two (2) remaining plastic washers to the remaining rear seat.

PARTS INFORMATION

DESCRIPTION	PART NUMBER	QUANTITY
Plastic Washer (c-clip)	23320-6TA1A	4

CLAIMS INFORMATION

Submit a Primary Part (PP) type line claim using the following claims coding:

DESCRIPTION	PFP	OP CODE	SYM	DIA	FRT
Install Plastic Washers	(1)	VX5YAA	ZL	32	0.2

- (1) Reference the electronic parts catalog and use the Rear Seat Frame as the Primary Failed Part (PFP).

AMENDMENT HISTORY

PUBLISHED DATE	REFERENCE	DESCRIPTION
May 11, 2022	ITB22-023	Original bulletin published

