



INFINITI

Nissan Group of the Americas
Copyright ©

TECHNICAL SERVICE BULLETIN

Classification: AN22-018	Reference: ITB22-027	Date: June 30, 2022
-----------------------------	-------------------------	------------------------

ENABLING WIRELESS APPLE CARPLAY® FEATURES

APPLIED VEHICLES: 2020-2021 QX80 (Z62)

SERVICE INFORMATION

To enable wireless use of current Apple CarPlay® features, follow the **SERVICE PROCEDURE** in this bulletin.

NOTE: Depending on the software version, the AV control unit may need to be updated. Perform steps 1-4 beginning on page 3 to check the software version.

Bulletins are intended for use by qualified technicians, not 'do-it-yourselfers'. Qualified technicians are properly trained individuals who have the equipment, tools, safety instruction, and know-how to do a job properly and safely. **NOTE:** If you believe that a described condition may apply to a particular vehicle, DO NOT assume that it does. See your Infiniti retailer to determine if this applies to your vehicle.

REQUIRED SPECIAL TOOL

- One of special tool USB drive J-52727-1 was previously shipped to each retailer and should already be available (Figure 1).
- Do not use any other USB drive to perform the procedure in this bulletin.
- Additional USB drives may be purchased from Tech•Mate: infinitytechmate.com or 1-800-662-2001.

HINT:

- The update-software only needs to be downloaded once, and can then be used continuously on multiple **APPLIED VEHICLES**.
- The update-software must be the only file on the USB drive.



Figure 1

SERVICE PROCEDURE

IMPORTANT: Configuration of the AV control unit (steps 27 - 45 on pages 11 - 18) and onboard navigation calibration (steps 56 - 65 on page 22) are required after the software update.

- If the configuration steps are not completed, the wireless CarPlay will not operate.
- Do not perform the onboard navigation calibration procedure if the software update was not performed.

Check the Software Version

1. On the main menu screen, select **Info**.



Figure 2

2. Select **System Information**.



Figure 3

3. Select **Version Information**.

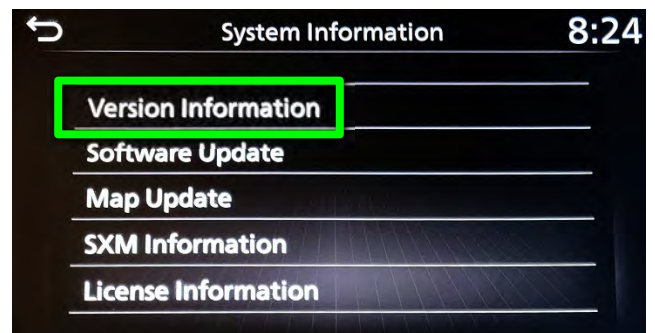

Figure 4

4. Confirm the **Software Version**.

- If the **Software Version** is lower than xxxxx2992x (digits 6-9 as shown in Figure 5), select the back icon and proceed to step 5 on page 5.
- If the **Software Version** is xxxxx2992x or higher (digits 6-9), select the back button and skip to step 27 on page 11 to configure the AV control unit.

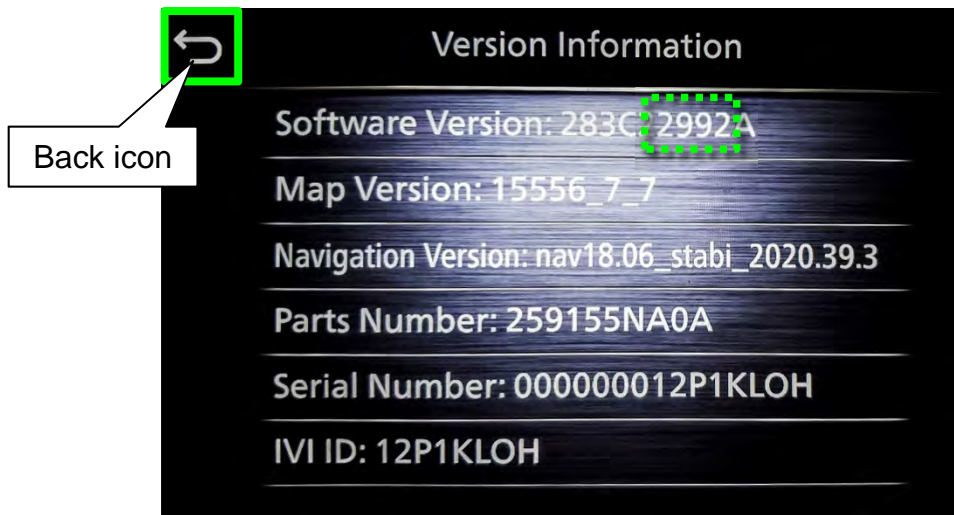

Figure 5

Update the AV Control Unit

IMPORTANT: Before starting, make sure:

- The CONSULT PC is connected to the internet.
- ASIST has been synchronized (updated) to the current date.

NOTE: In the following steps, if more than one CONSULT PC is available and the **PVI002** infotainment update-software has already been downloaded through ASIST to one of them, use the CONSULT PC with the pre-existing download.

5. Insert special tool USB drive J-52727-1 into the CONSULT PC.

- If the infotainment software has already been downloaded onto special tool USB drive J-52727-1 from a prior service procedure, skip to step 14 on page 7.

HINT:

- Special tool USB drive J-52727-1 is the only USB drive approved for use with this procedure.
- The initial download of the update-software to the CONSULT PC and file transfer to the USB drive is estimated to take **6 hours**. After the initial download of the update-software, file transfer to the USB drive is estimated to take 1 hour.
- The update-software must be the only file on the USB drive.

6. Open ASIST.

7. Select **Specialty Tools**, and then select **Infotainment Software Updates**.

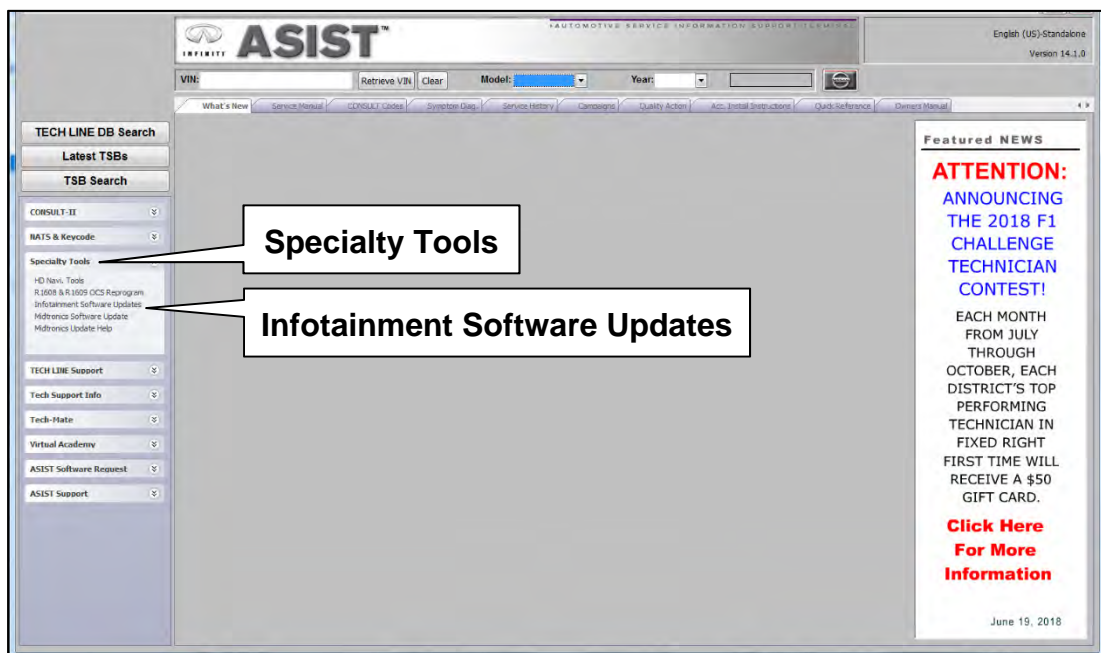

Figure 6

8. Select the check box next to the **PVI002** infotainment update-software (Figure 7).
9. Use the drop-down menu and select the location of the USB drive that was inserted in step 5 on page 5.

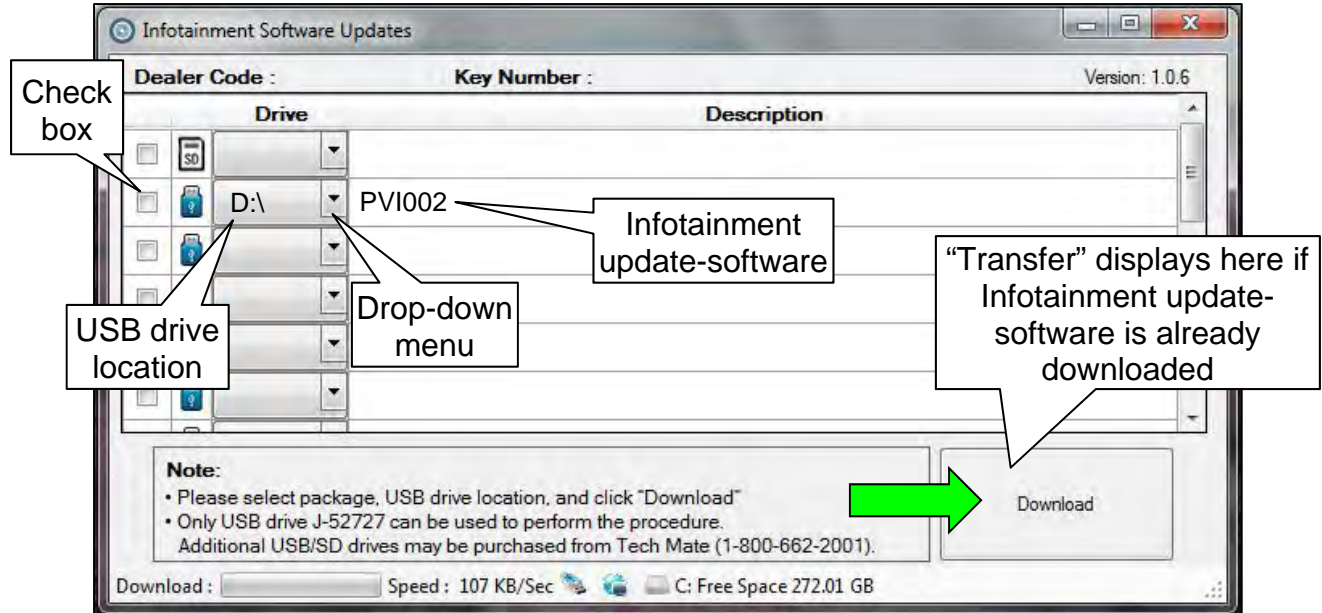

Figure 7

10. Select **Download**, and then wait for the download to complete.
 - If the **PVI002** infotainment update-software has already been downloaded, “Transfer” will be displayed instead of “Download” when the infotainment software update box is checked.

HINT:

- The initial download of the update-software to the CONSULT PC and file transfer to the USB drive is estimated to take **6 hours**. After the initial download of the update-software, file transfer to the USB drive is estimated to take 1 hour.
- If while attempting to download the update-software to the CONSULT PC, you receive the message shown in Figure 8:
 - a. First attempt to clear space on the CONSULT PC hard drive (40 GB required).
 - b. If space cannot be cleared and a second CONSULT PC is available with space, use it and start over from step 5 on page 5.



Figure 8

11. Select **OK**.

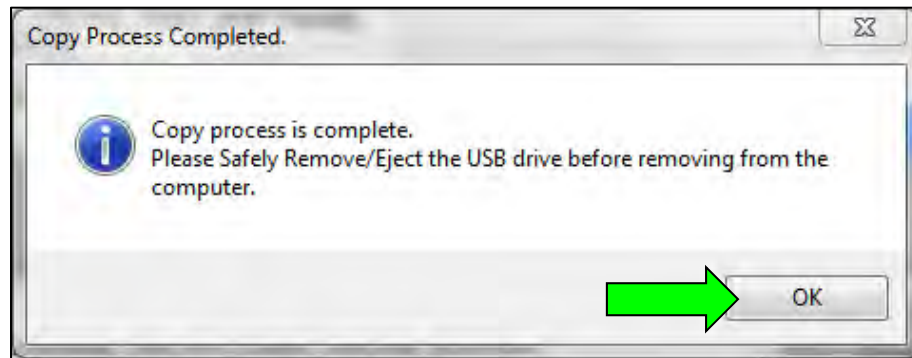

Figure 9

12. Once the transfer is complete, safely remove the USB drive from the CONSULT PC.
 - a. From the PC toolbar, select the **Safely Remove Hardware** icon.
 - o The icon is on the toolbar, or can be found after selecting the arrow.
 - b. Select the USB drive to be removed, and then remove the USB drive from the CONSULT PC.

NOTICE

Follow the steps to safely remove the USB drive. If not followed, the USB drive may corrupt the infotainment update-software.

- o If you are not familiar with the process of safe USB drive removal, ask for assistance at your retailer.

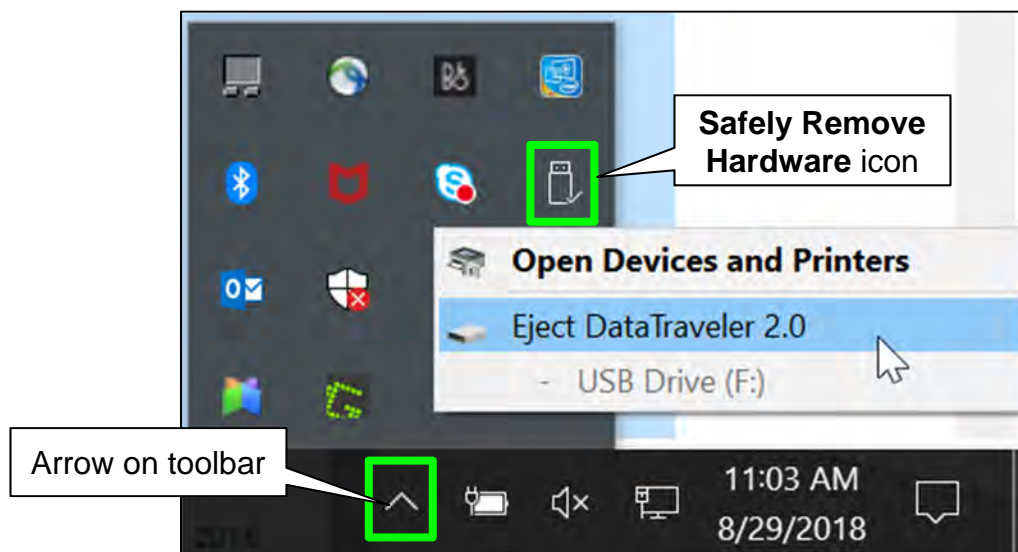

Figure 10

13. Close all ASIST **Infotainment Software Update** screens.
14. Set the parking brake.
15. Start the engine, and then wait 60 seconds for the system to load.

HINT: The engine needs to idle for the duration of the update to retain battery charge.

16. Insert the USB drive with the infotainment update-software into the vehicle's USB media port (Figure 11).

HINT: Charging ports are marked in the vehicle with a “lightning bolt” symbol (Figure 12).

NOTICE

- Do not insert the USB drive into a charging port. If used, the update-software and/or USB drive may become damaged. Only insert the USB drive in a USB media port.
- Do not remove the USB drive during the update to the vehicle until instructed to. If the USB drive is removed during the update, the AV control unit may become damaged.

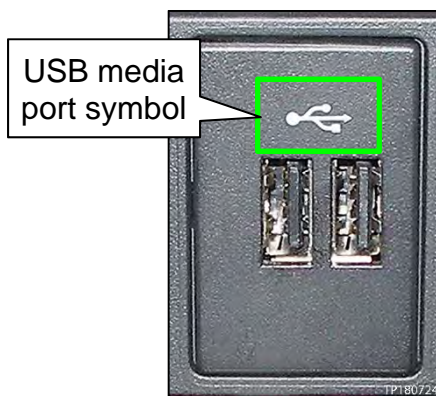

Figure 11

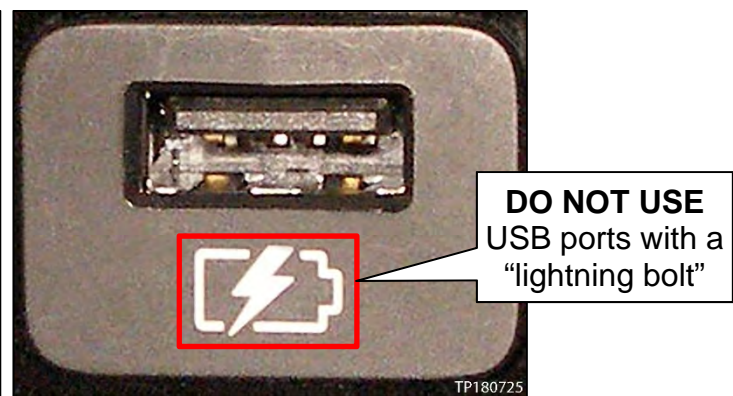

Figure 12

17. Wait for the update to complete.
- Follow the on-screen instructions while waiting.

HINT: The update lasts 15-25 minutes.

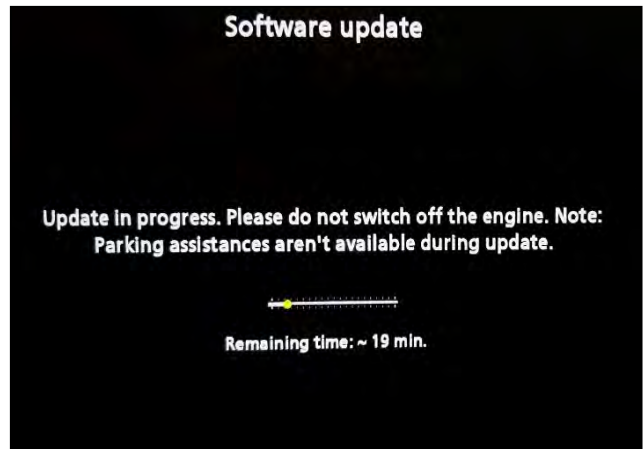

Figure 13

18. Once the update is complete (Figure 14), remove the USB drive; the system will reboot (restart).

HINT: The system will not reboot until the USB drive is removed.

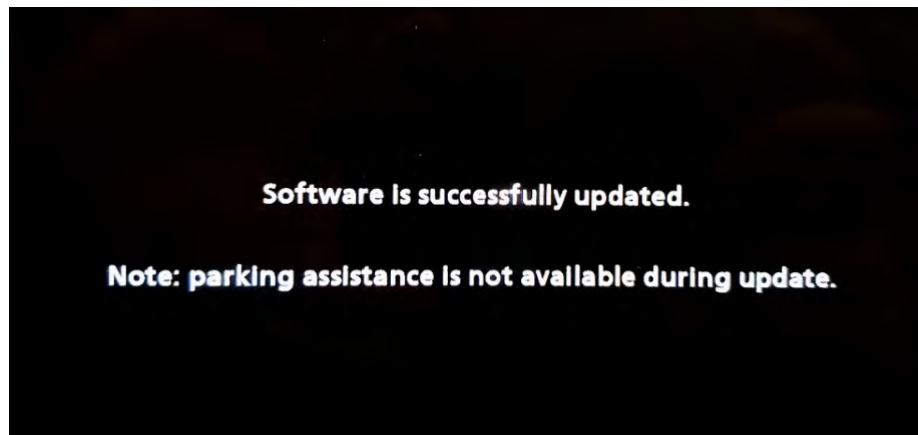

Figure 14

NOTICE

Steps 19 - 26 must be completed. If they are not completed, the update may become corrupted.

19. Allow the reboot to complete (approximately 30 seconds).
- The Infiniti logo will be displayed during the reboot.



Figure 15

20. Turn the ignition OFF.

The steps below will fully reboot the infotainment system twice.

21. Open and close the driver (LH) door, and then ensure that all doors are closed.

22. Wait 5 minutes.

NOTICE

Ensure that all doors remain closed during the 5-minute wait period. If a door is opened during the 5-minute wait period, the update may not complete and the AV control unit may become inoperable.

HINT: The engine does not need to be running for the next steps.

23. Turn the ignition ON (engine OFF) and wait for the Infiniti logo to appear (Figure 15 on page 9).

- If the Infiniti logo does not appear (this might take up to 30 seconds), start over from step 20.

24. After the Infiniti logo appears, wait about 1 minute.

- The **MENU** (Home) screen in Figure 16 will be displayed.

25. Turn OFF the ignition.



Figure 16

26. Repeat steps 21 - 25 one more time (for a total of two [2] times) to complete the update.

Configure Wireless CarPlay

27. Connect a battery maintainer/smart charger to the vehicle.
28. Connect the VI to the vehicle.
29. Start C-III plus.
30. Wait for the VI to be recognized (Figure 17).
 - The serial number will display when the VI is recognized.
31. Select **Re/programming, Configuration**.

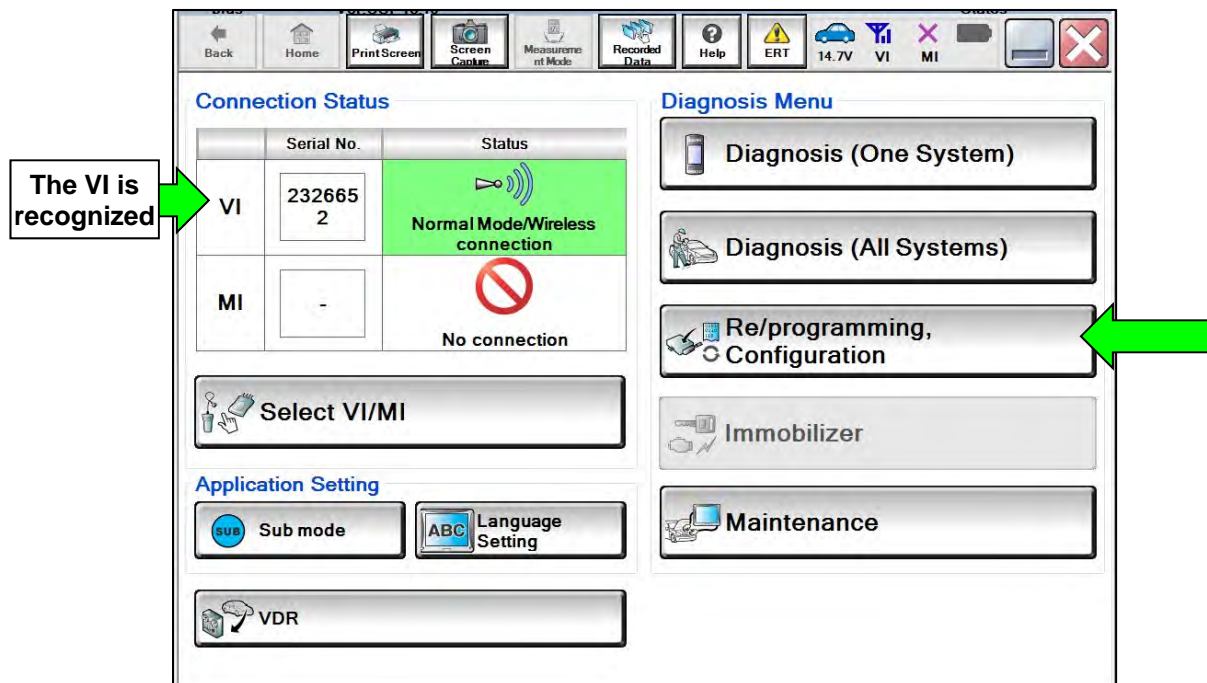

Figure 17

32. Check the box to confirm the precaution instructions have been read, and then select **Next**.

NOTE: Use the arrows (if needed) to view and read all the precautions.

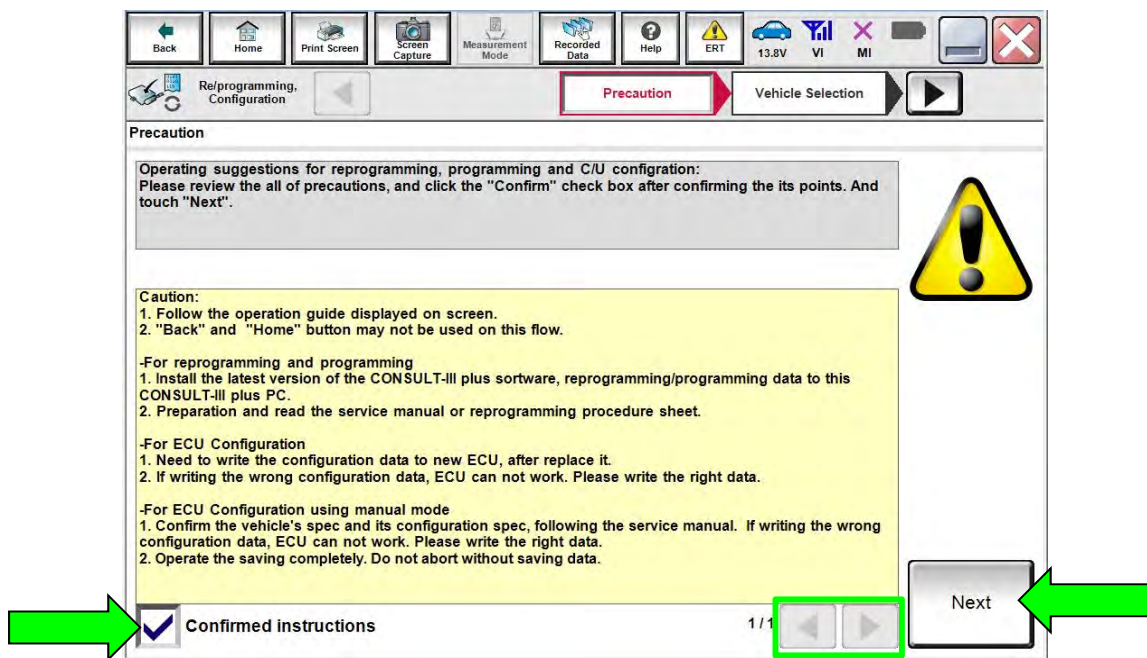

Figure 18

33. Select **Manual Selection(Vehicle Name)**, select the applicable **Vehicle Name** and **Model Year**, and then select **Select**.

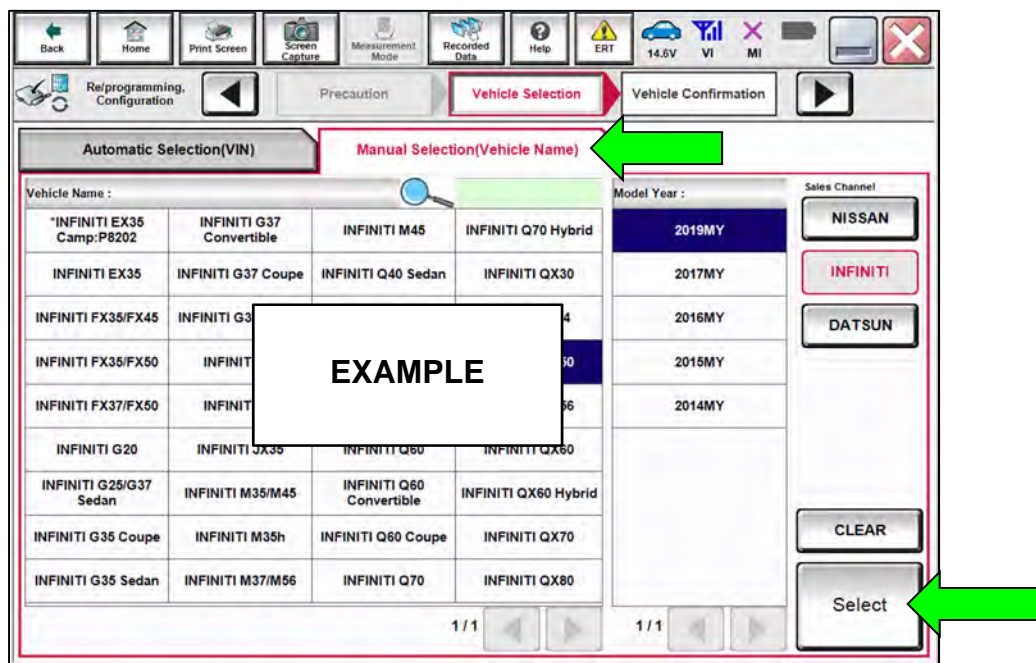

Figure 19

34. Confirm the **VIN or Chassis #** is correct, and then select **Confirm**.

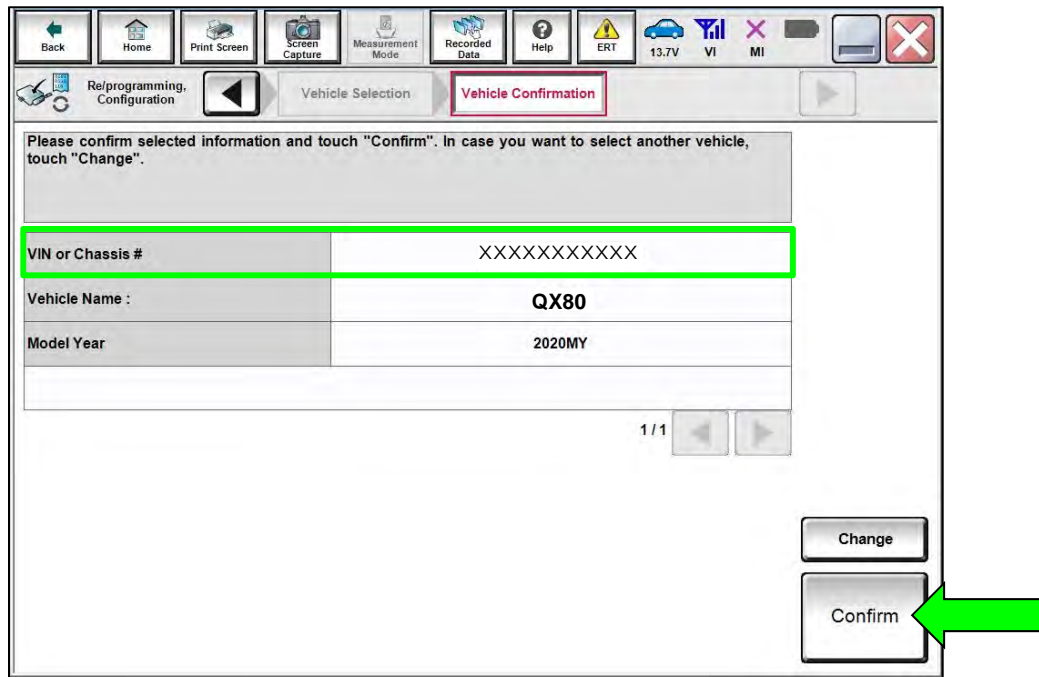

Figure 20

35. Confirm the VIN is correct for the vehicle, and then select **Confirm**.

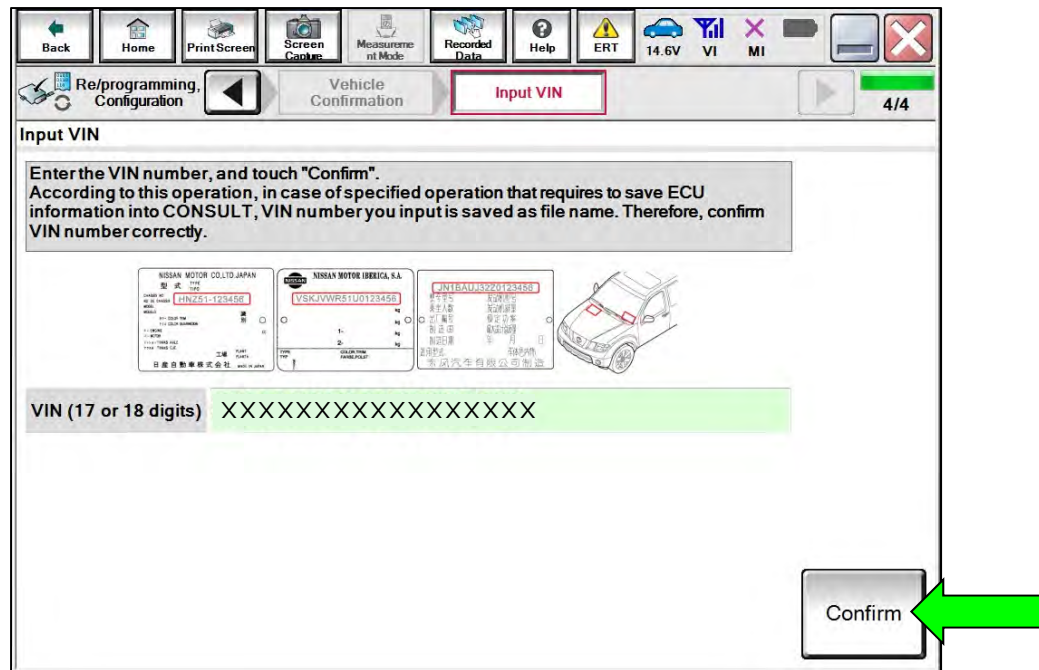

Figure 21

36. Select **MULTI AV**.

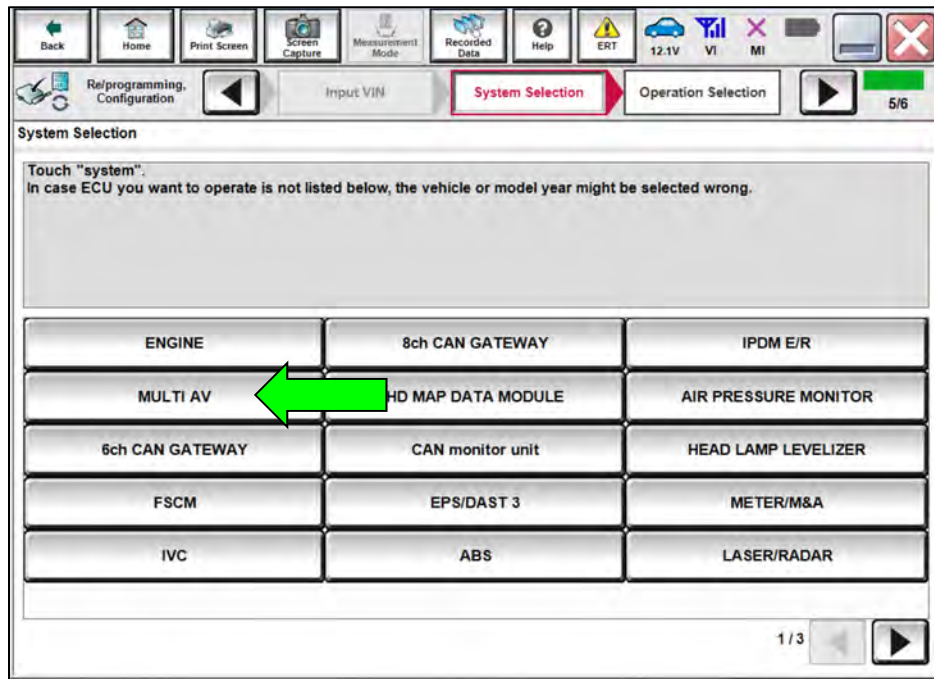

Figure 22

37. Select **Before ECU Replacement** under **VEHICLE CONFIGURATION**.

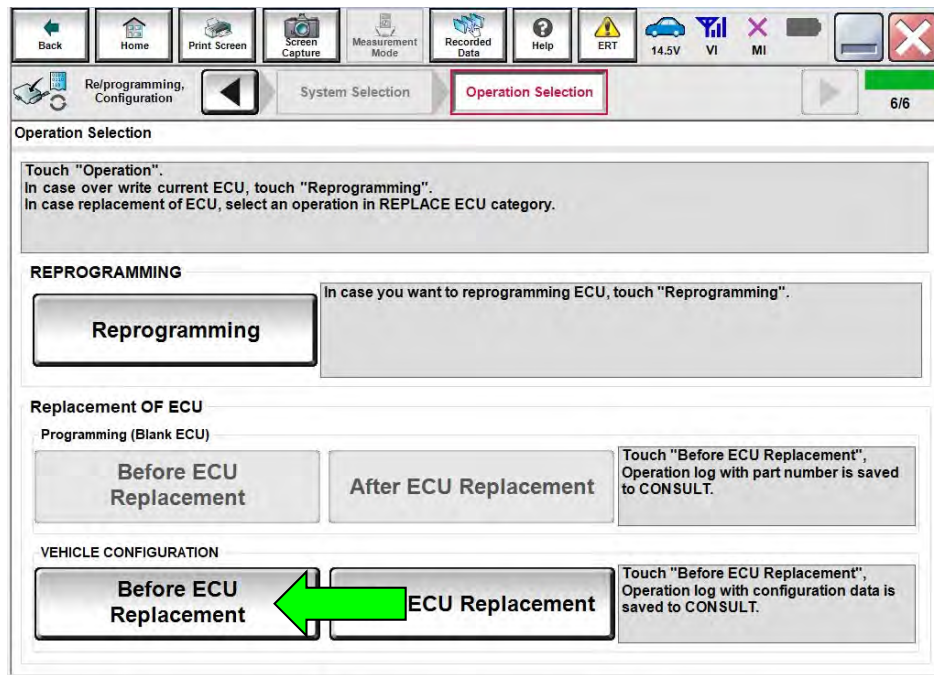

Figure 23

38. Scroll through each of the pages of configuration items and write down each of the **Items** and its **Setting Value**.

- If a printer is connected to the CONSULT PC, you may select **Print**.

IMPORTANT: Write down or print all the configuration settings, as these settings will be used in step 42 on page 16.

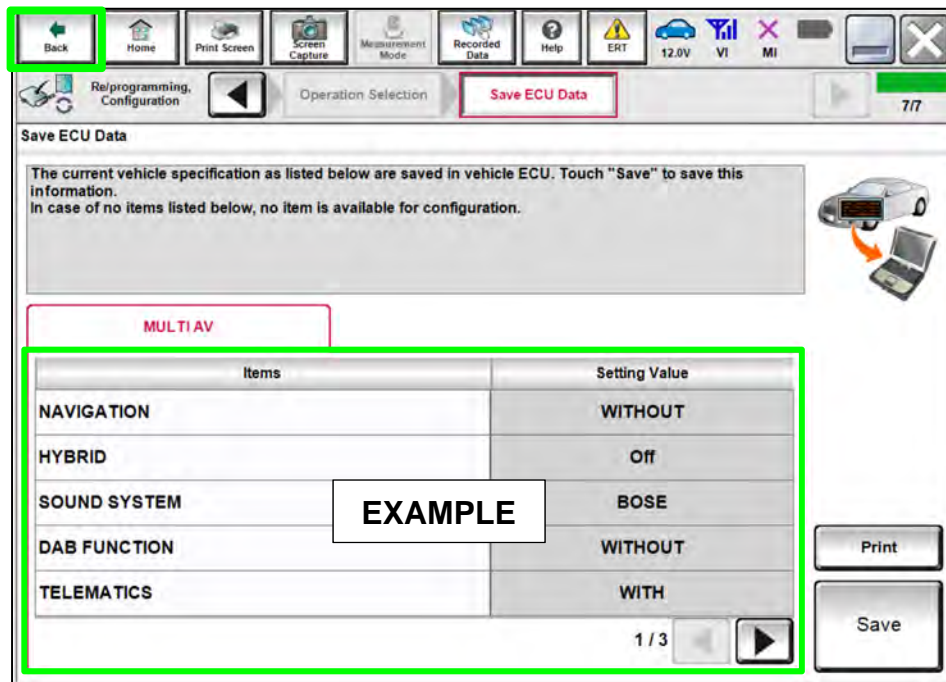

Figure 24

39. After the current configurations have been written down or printed, select **Back** in the upper LH corner of the screen (Figure 24).

40. Select **After ECU Replacement** under **VEHICLE CONFIGURATION**.

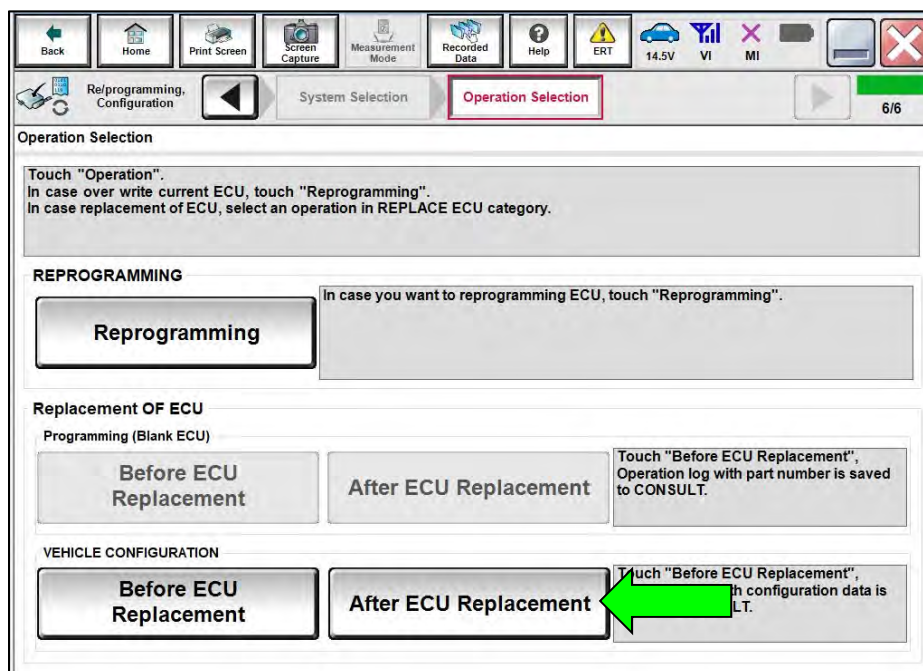

Figure 25

41. Select **Manual selection**.

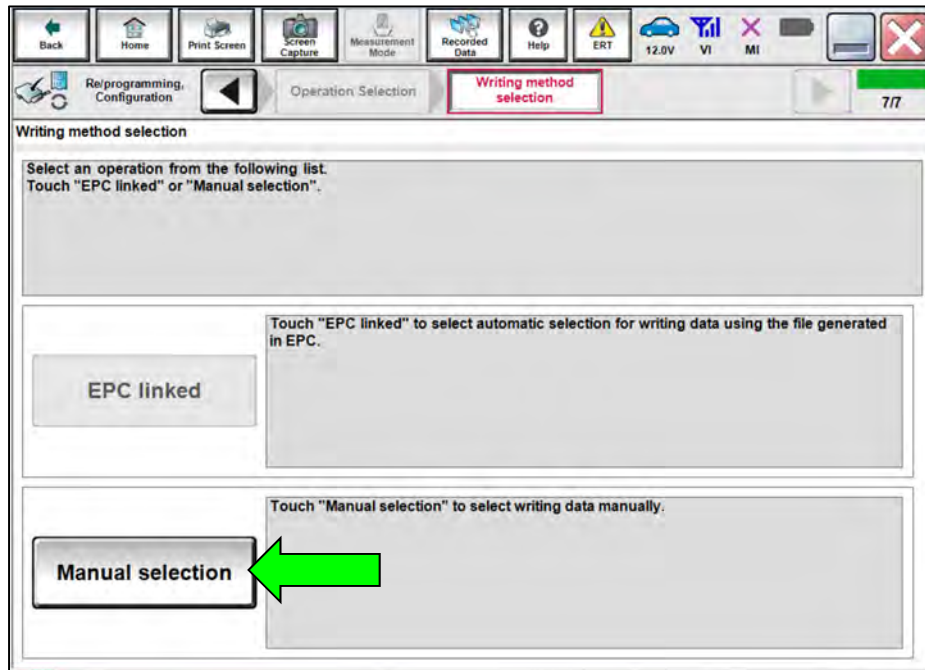

Figure 26

42. Use the drop down menus to select the configuration options that were printed or written down in step 38 on page 15, and then select **Next**.

IMPORTANT: The default **Setting Value** for **Wireless CarPlay** is "WITHOUT". Be sure to change this **Setting Value** to "WITH" (Figure 27).

NOTE: If needed, refer to the table on page 23, and select the applicable specification for the vehicle you are working on.

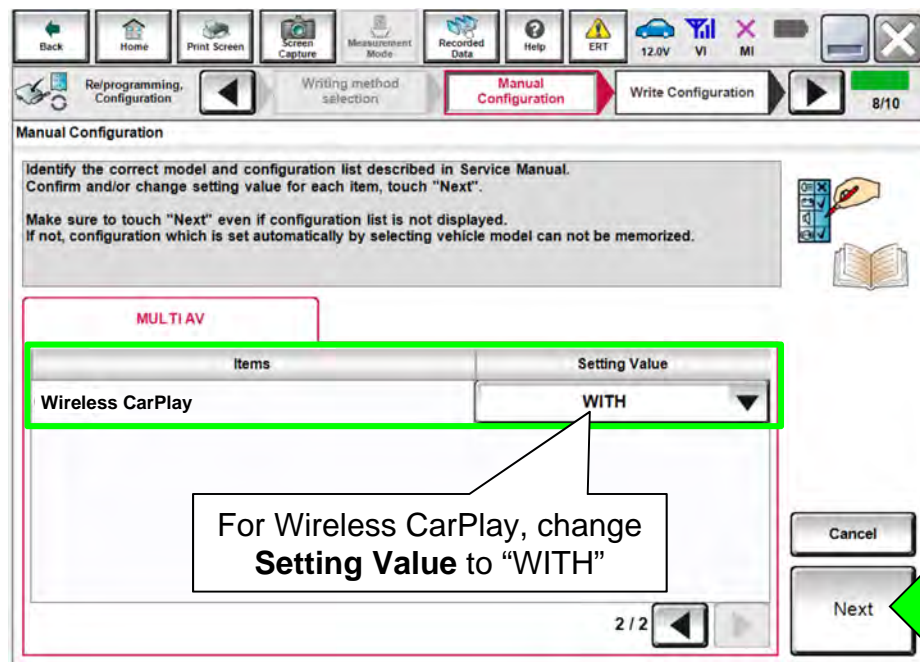

Figure 27

43. Confirm the configuration displayed is correct, and then select **OK**.

IMPORTANT: Be sure the **Setting Value** for **Wireless CarPlay** is “WITH” before selecting **OK**.

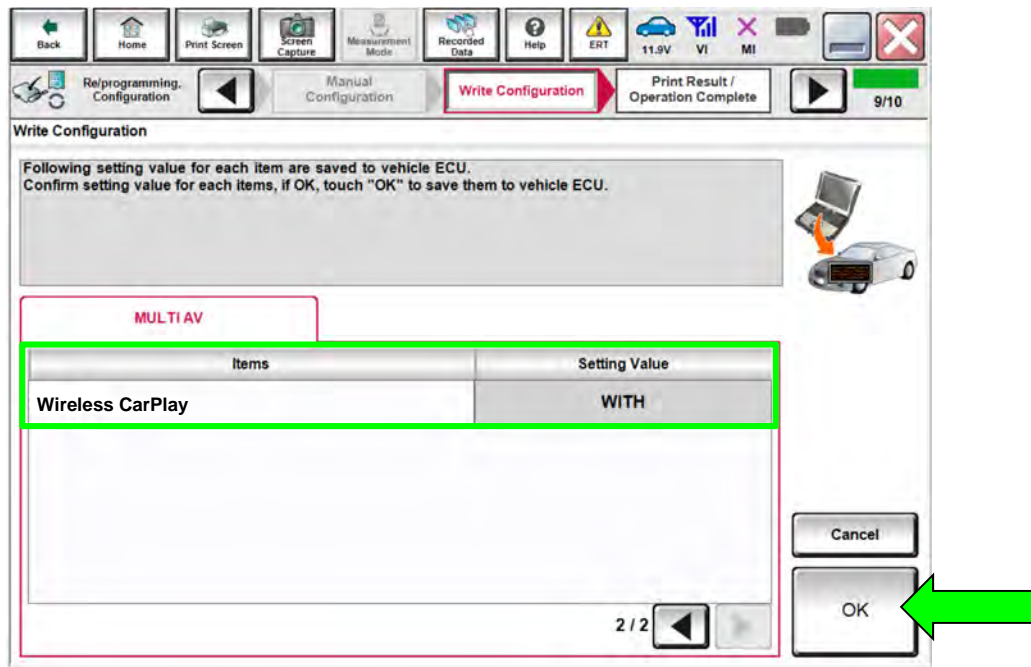

Figure 28

44. Allow configuration to transfer to the vehicle.

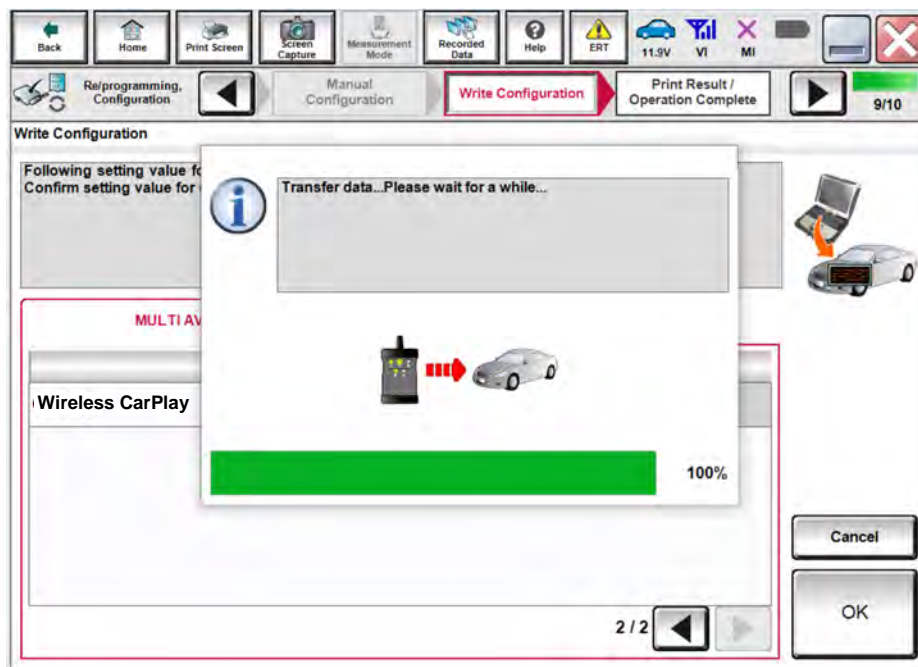

Figure 29

45. Select **End**.

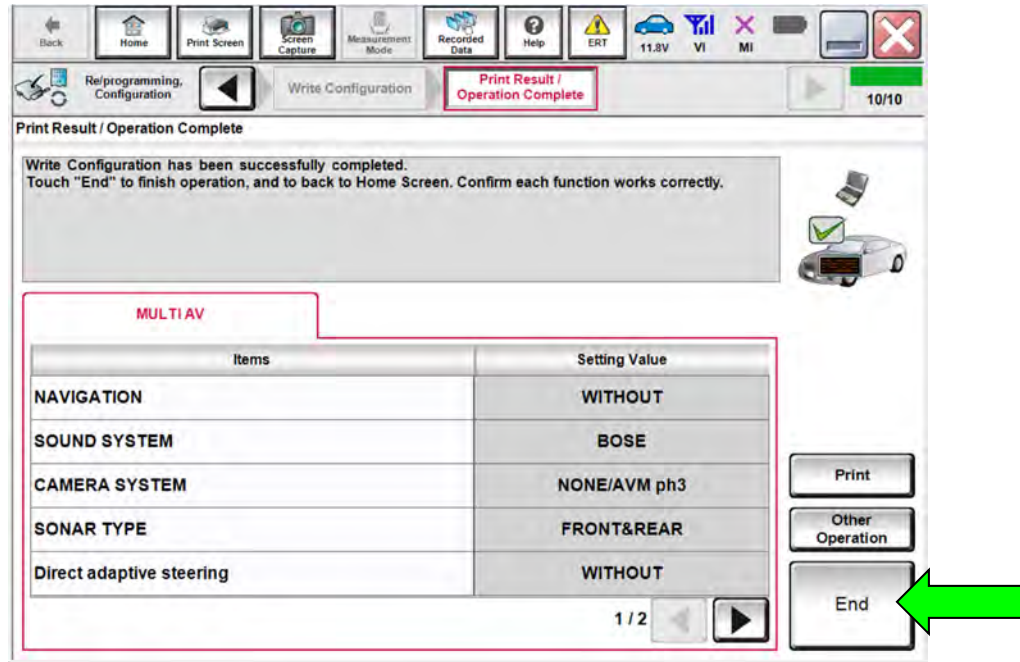

Figure 30

Erase DTCs

46. Select **Diagnosis (All Systems)**.

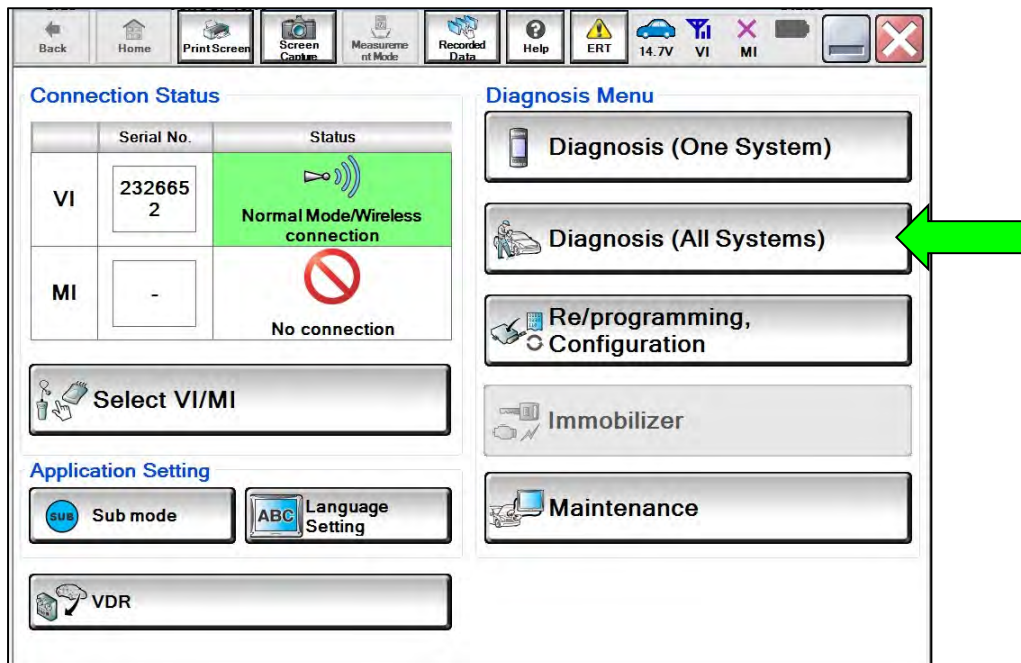

Figure 31

49. Confirm the **VIN or Chassis #** is correct, and then select **Confirm**.

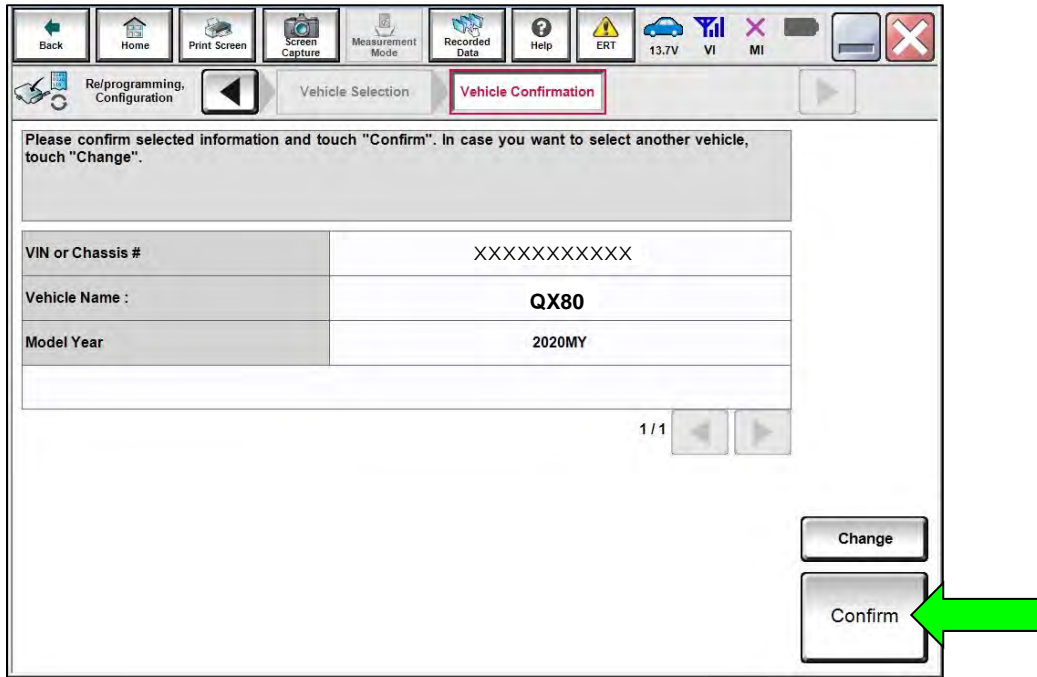

Figure 34

50. Select **ERASE**.

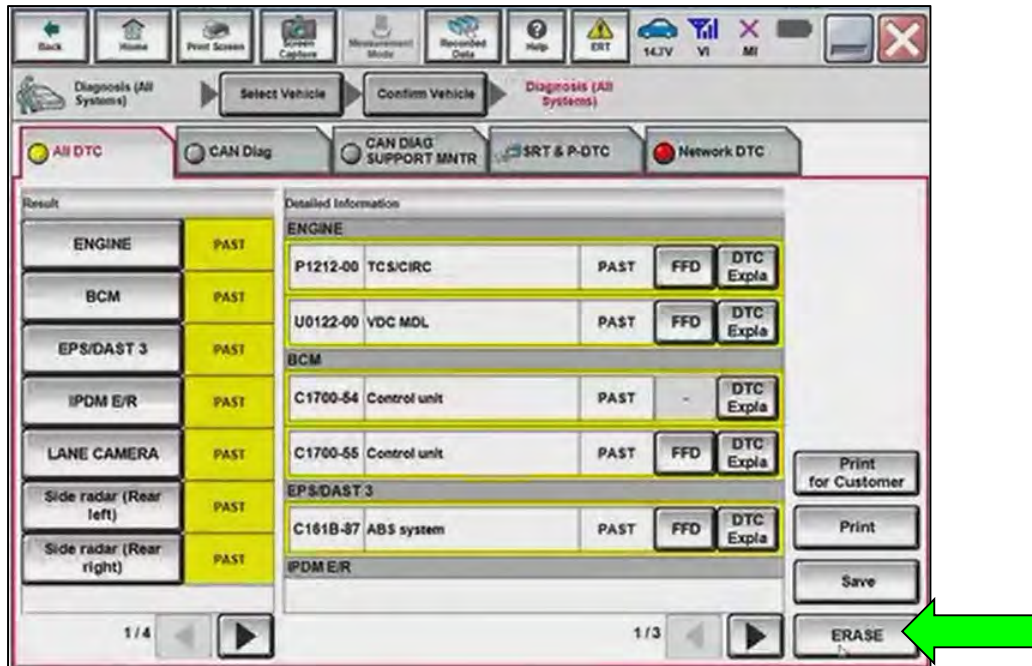

Figure 35

51. Select **Execute**.

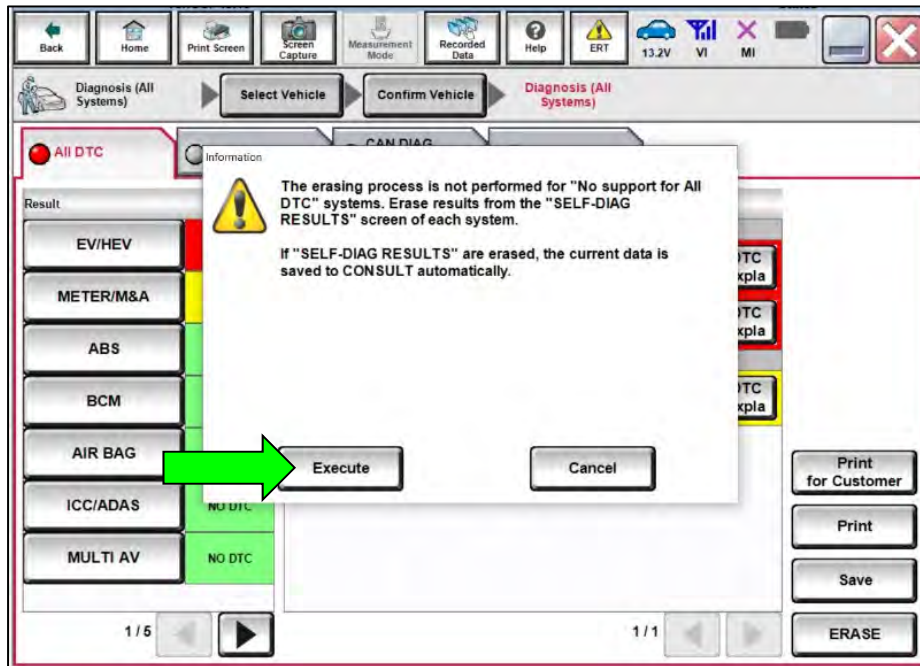

Figure 36

52. Select **Close**.

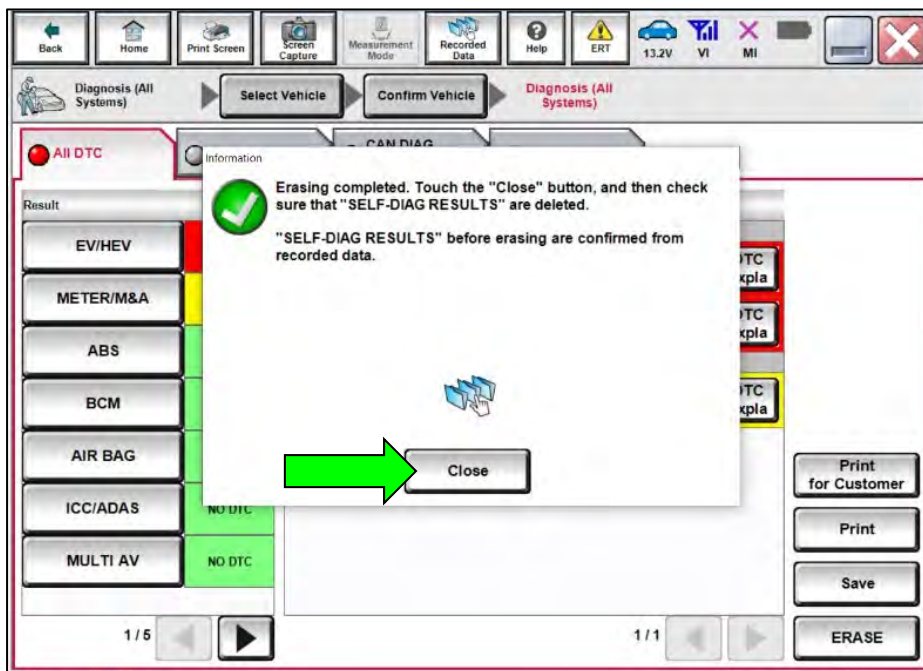

Figure 37

53. Close C-III plus.

54. Remove the VI from the vehicle.

55. Disconnect the battery maintainer/smart charger.

Calibrate Onboard Navigation

IMPORTANT: Perform this procedure only if the software update was performed.

56. Using a suitable tool, detach the Upper Ventilator Grille but do not remove it.

57. Disconnect the Sunload Sensor harness.

NOTICE

To avoid damage to the Sunload Sensor harness, it must be disconnected before performing the next steps. If not disconnected, damage to Sunload Sensor harness may occur.

58. Remove the Upper Ventilator Grille.

NOTICE

To avoid damage to the Instrument Panel and/or Center Speaker, the Upper Ventilator Grille must be completely removed before performing the next steps. If not removed, damage to the Instrument Panel and/or Center Speaker may occur.

59. Turn the headlamps ON.

60. Drive the vehicle 3-6 miles AND for a minimum of 10 minutes.

61. Turn the engine OFF, and wait 5 minutes before proceeding to the next step.

NOTE: The ignition must also be OFF during this time.

62. Drive the vehicle a short distance (approximately ¼ mile).

63. Confirm the navigation system is displaying the correct location.

- If the correct location is not displayed, perform steps 60-63 again.

64. Turn the headlamps OFF.

65. Reattach the Sunload Sensor harness and the Upper Ventilator Grille.

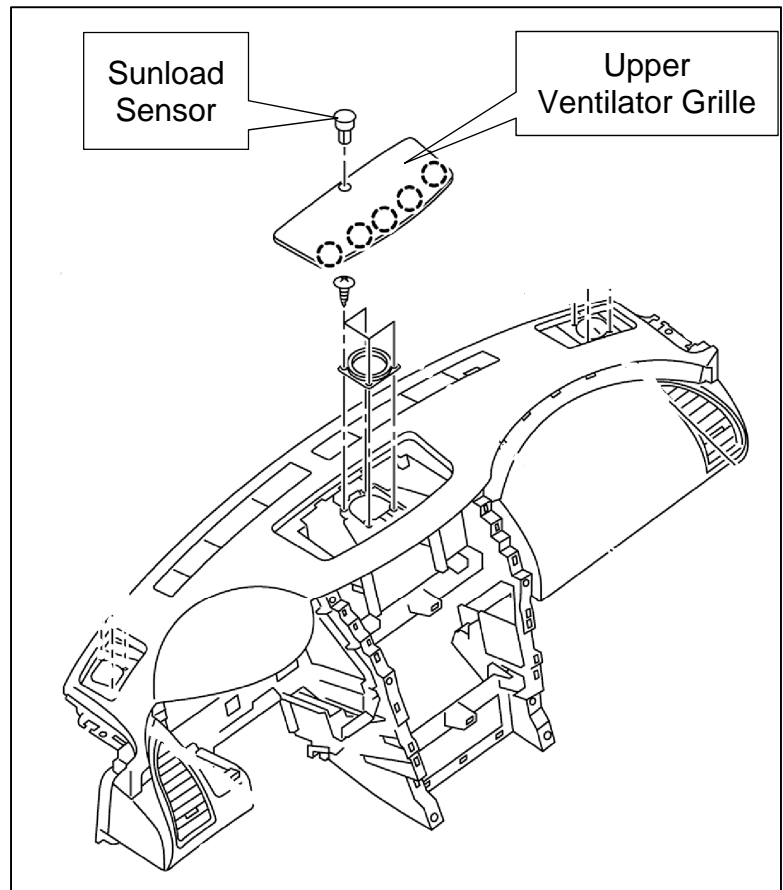

Figure 38

2020 QX80 (Z62)

MANUAL SETTING ITEM		DETAIL
Items	Setting Value	
TELEMATICS	WITH	Models with telematics system
	WITHOUT	Models without telematics system
ANTI-THEFT CONTROL	WITH	Models with anti-theft system
	WITHOUT	Models without anti-theft system
Mobile entertainment system	WITH	Models with rear entertainment system
	WITHOUT	Models without rear entertainment system
FEB SYSTEM	OFF	Models without forward emergency brake system
	ON	Models with forward emergency brake system
AUDIO AMP TYPE	4ch AMP	Models with 13 speakers
	BosePerformance AMP	Models with 17 speakers
DESTINATION	U.S.A	For United States of America
	Canada	For Canada
	EUR	For Europe
	Russia	For Russia
	Mexico	For Mexico
	LAM	For Latin America
	Vietnam	For Vietnam
Wireless CarPlay	WITHOUT	Set this item to WITH.
	WITH	

2021 QX80 (Z62)

MANUAL SETTING ITEM		DETAIL
Items	Setting Value	
TELEMATICS	WITH	Models with telematics system
	WITHOUT	Models without telematics system
DAB FUNCTION	WITH	Applicable
	WITHOUT	Not applicable
Mobile entertainment system	WITH	Models with rear entertainment system
	WITHOUT	Models without rear entertainment system
FEB SYSTEM	OFF	Models without forward emergency brake system
	ON	Models with forward emergency brake system
NAVIGATION	WITH	Models with navigation system
	WITHOUT	Models without navigation system
AUDIO AMP TYPE	4ch AMP	Models with 13 speakers
	BosePerformance AMP	Models with 17 speakers
DESTINATION	U.S.A	For United States of America
	Canada	For Canada
	EUR	For Europe
	Russia	For Russia
	Mexico	For Mexico
	LAM	For Latin America
	GCC	For The Middle East (Gulf Cooperation Council)
Vietnam	For Vietnam	
Wireless CarPlay	WITHOUT	Set this item to WITH.
	WITH	

AMENDMENT HISTORY

PUBLISHED DATE	REFERENCE	DESCRIPTION
June 30, 2022	ITB22-027	Original bulletin published