



VOLUNTARY SERVICE CAMPAIGN

Classification: HA22-004	Reference: NTB22-059	Date: July 22, 2022
-----------------------------	-------------------------	------------------------

VOLUNTARY EMISSION SERVICE CAMPAIGN 2022 PATHFINDER; A/C CONDENSER PIPE

CAMPAIGN ID #: PC899
APPLIED VEHICLES: 2022 Pathfinder (R53)

**Check Service COMM or Dealer Business Systems (DBS)
National Service History to confirm campaign eligibility.**

INTRODUCTION

Nissan is conducting this voluntary emission service campaign, on certain specific model year 2022 Pathfinder vehicles, to replace the A/C condenser pipe. This service will be performed at no charge to the customer for parts or labor.

IDENTIFICATION NUMBER

Nissan has assigned identification number PC899 to this campaign. This number must appear on all communication and documentation of any nature dealing with this campaign.

DEALER RESPONSIBILITY

Dealers are to repair vehicles falling within range of this campaign that enter the service department. This includes vehicles purchased from private parties, vehicles presented by transient (tourists) owners, and vehicles in a dealer's inventory.

Bulletins are intended for use by qualified technicians, not 'do-it-yourselfers'. Qualified technicians are properly trained individuals who have the equipment, tools, safety instruction, and know-how to do a job properly and safely. **NOTE:** If you believe that a described condition may apply to a particular vehicle, DO NOT assume that it does. See your Nissan dealer to determine if this applies to your vehicle.

SERVICE PROCEDURE

1. Open the hood and use the hood support rod to support the hood.
2. Install a protective fender cover.

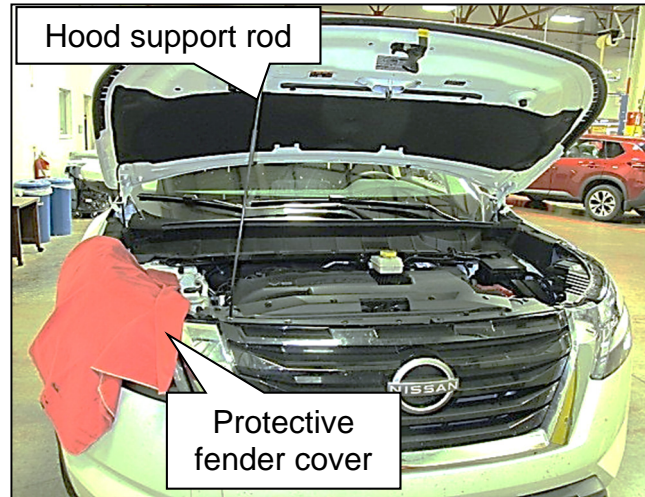

Figure 1

3. Recover the refrigerant using approved equipment.
 - Refer to the ESM: **VENTILATION, HEATER & AIR CONDITIONER > HEATER & AIR CONDITIONING SYSTEM > PERIODIC MAINTENANCE > REFRIGERANT > Recycle Refrigerant**



Figure 2

4. Remove the core support cover.
 - Using a suitable tool, remove the thirteen (13) retaining clips, and then remove the core support cover.

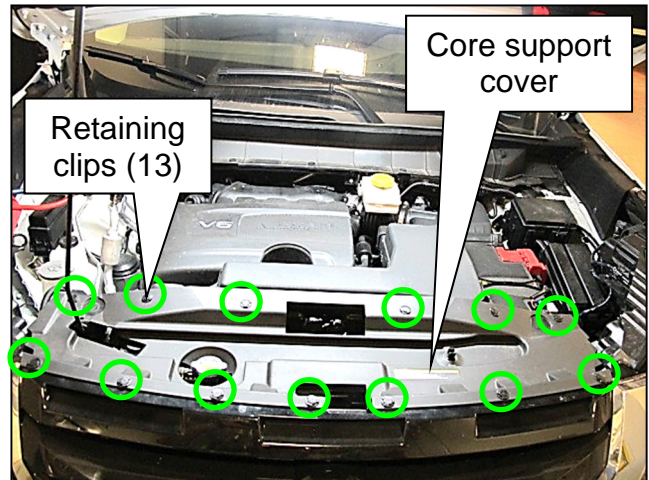

Figure 3

5. Remove the splash guard (air duct).
 - Using a suitable tool, remove the three (3) retaining clips, and then remove the splash guard.

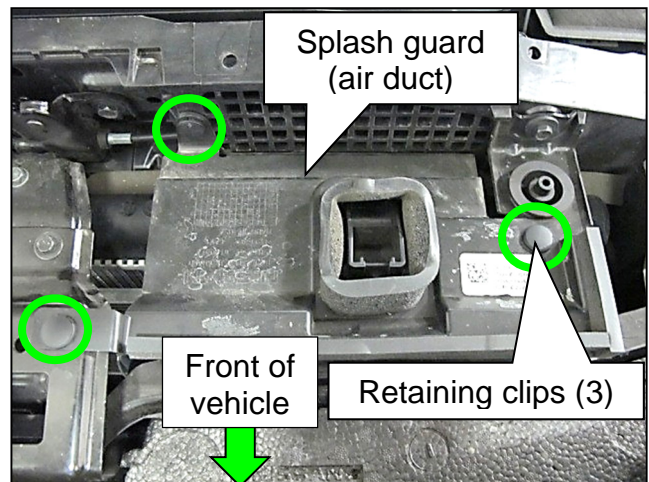

Figure 4

- Using a suitable tool, remove the top passenger (RH) side (Figure 5) and the top driver (LH) side (Figure 6) front grille retainer clips.

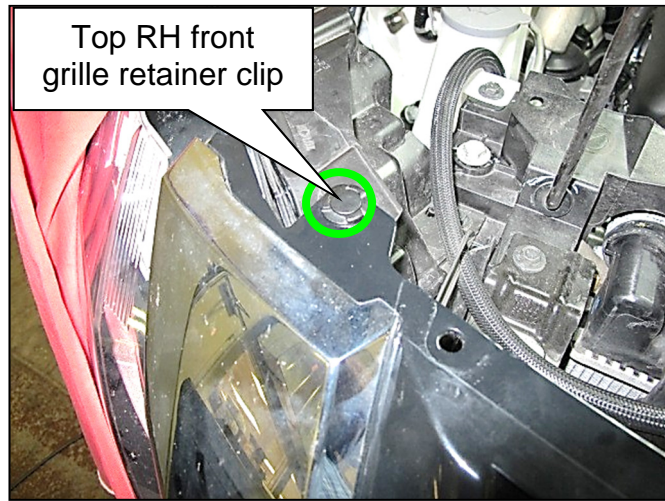

Figure 5

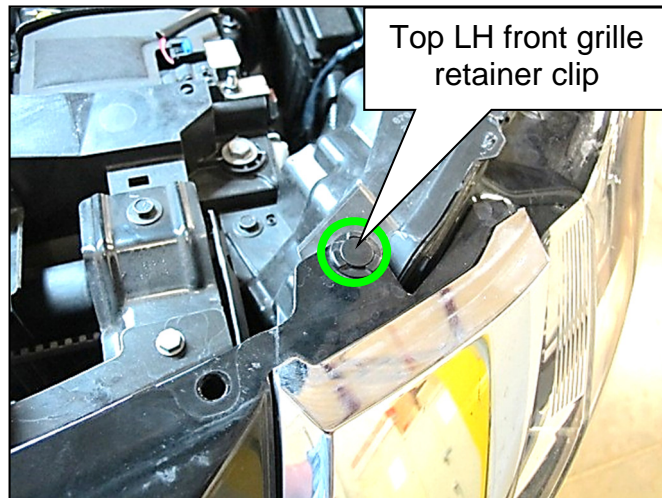

Figure 6

7. Gently pull out the top of the passenger (RH) side (Figure 7) and the driver (LH) side (Figure 8) front grille ONLY.
- When gently pulling forward on the front grille, the clips/pawls should release and allow the front grille to move forward.

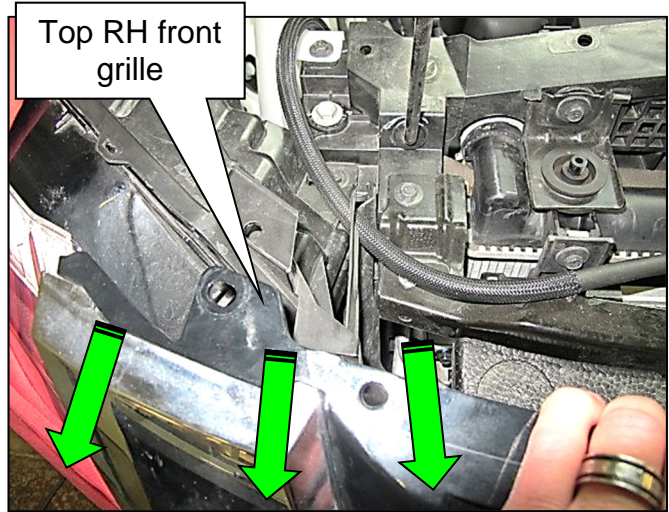

Figure 7

NOTE: Complete removal of the front grille assembly from the vehicle is not required.

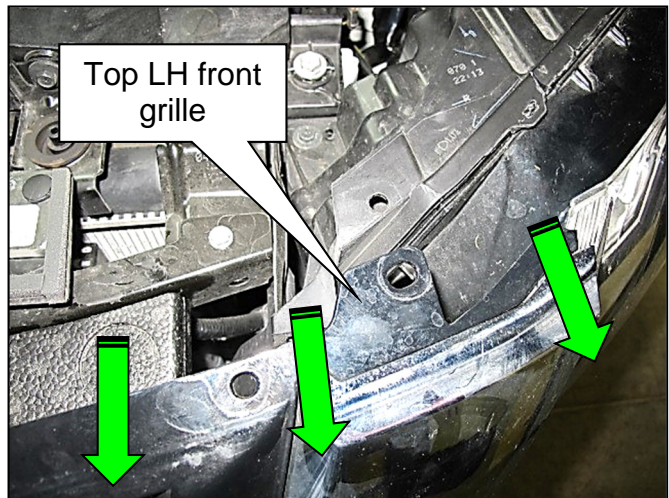

Figure 8

8. Remove the front bumper energy absorber.
 - a. Locate the backside of the two (2) retaining tabs in the core support and push them forward with a finger to release them from the core support.
 - b. Push the front bumper energy absorber forward and lift it out.
 - c. Discard the front bumper energy absorber, it will not be reused.

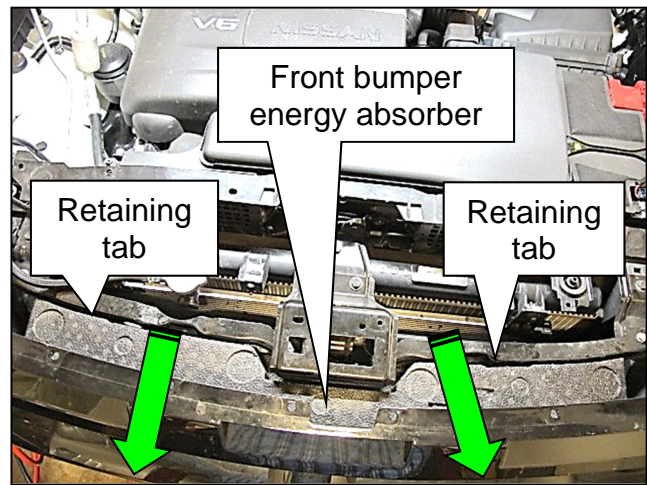

Figure 9

9. Locate the A/C high pressure condenser pipe connections in the engine compartment, where shown in Figure 10 and Figure 11.

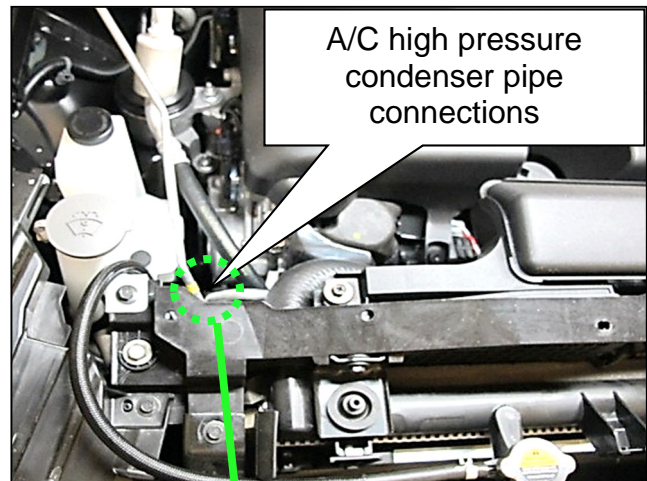

Figure 10

10. Remove the two (2) 12 mm A/C high pressure condenser pipe retaining bolts in the engine compartment, where shown in Figure 11.

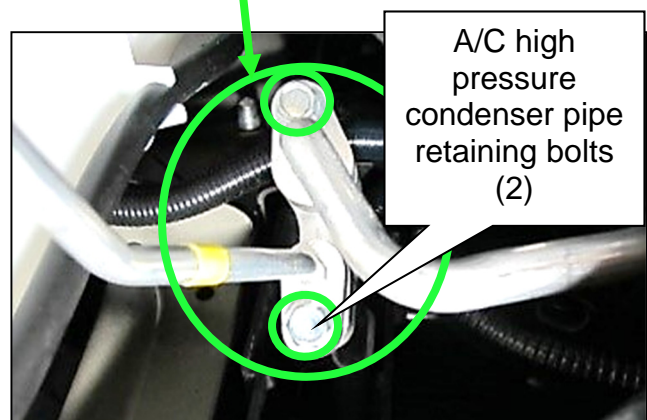

Figure 11

11. Disconnect the high pressure pipe and the high pressure flex-hose connections (Figure 12).
 - a. Gently pull and wiggle each pipe to allow the O-ring and captured seal to release.



Figure 12

- b. Remove and discard the O-ring seal and the captured seal from each high pressure pipe, they will not be reused (Figure 13).
 - c. Cap off or use a suitable material such as vinyl tape, to wrap the high pressure pipe and the high pressure flex-hose connections (vehicle side) to avoid the entry of air.

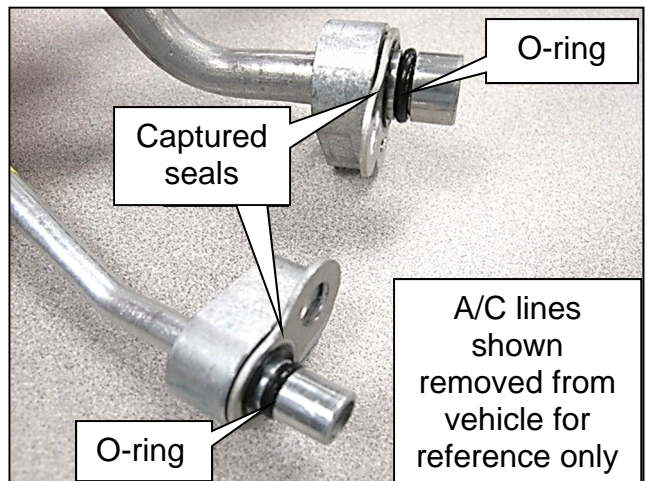

Figure 13

12. Locate the A/C condenser pipe connections at the A/C condenser (Figure 14).

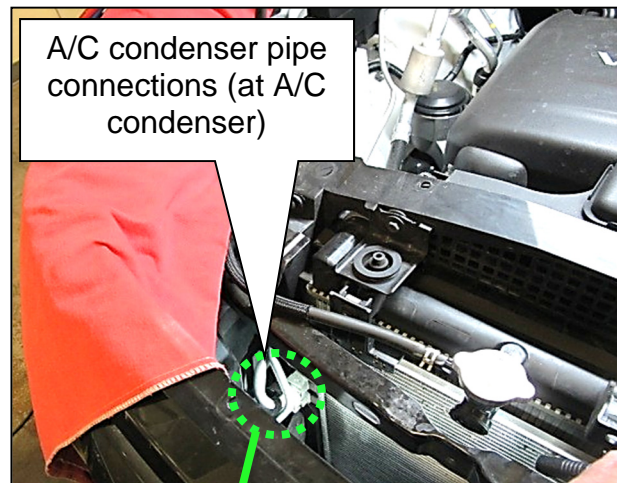

Figure 14

13. Remove the two (2) 10 mm A/C condenser pipe retaining bolts at the A/C condenser, where shown in Figure 15.

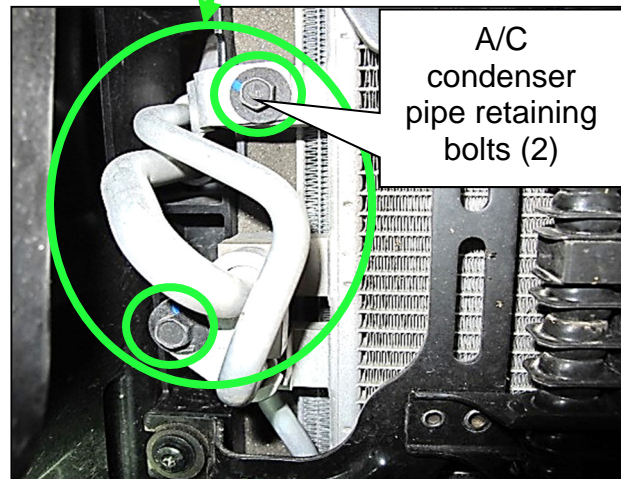

Figure 15

14. Disconnect the A/C condenser pipe from the A/C condenser (Figure 16).
- Gently pull the A/C condenser pipe away from the A/C condenser.

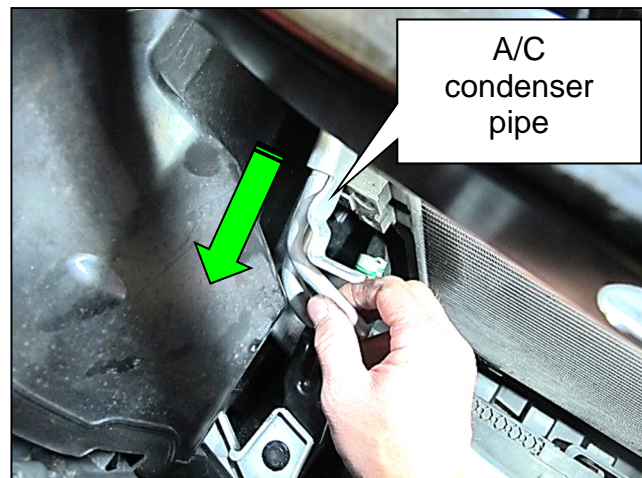

Figure 16

15. Remove the A/C condenser pipe from the vehicle.

- a. Pull the A/C condenser pipe forward, halfway through the radiator core support (Figure 17).

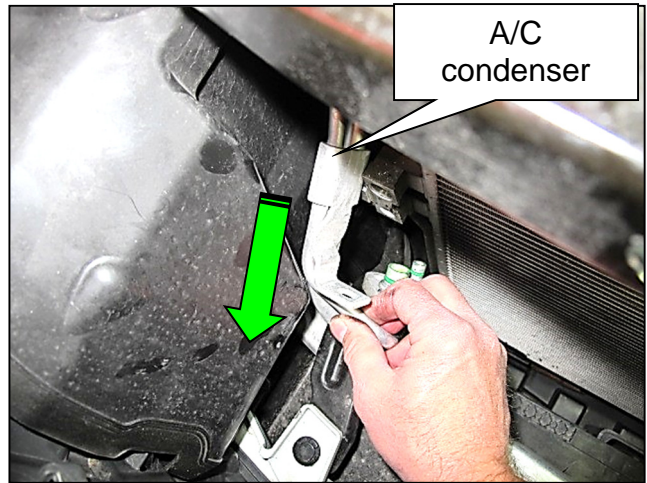

Figure 17

- b. Pull down on the A/C condenser pipe as it threads through the radiator core support to remove it from the vehicle (Figure 18).
- c. Cap off or use a suitable material, such as vinyl tape, to wrap the A/C condenser pipe openings on the A/C condenser to avoid the entry of air.

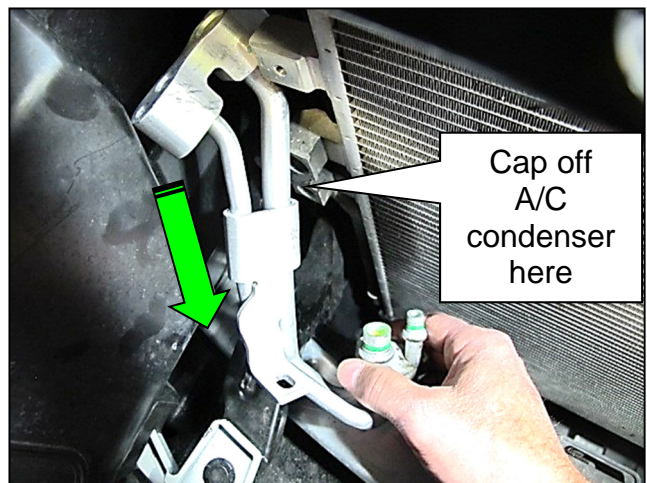

Figure 18

16. Install the new A/C condenser pipe.
- a. Remove the protective covers from the new A/C condenser pipe.
 - b. Verify the O-rings are present and undamaged (Figure 19).
 - o The new A/C condenser pipe will be supplied with new O-rings installed on the end that mates to the A/C condenser.
 - c. Apply the correct refrigerant oil (PAG VC100YF) to all the new A/C condenser pipe O-rings and seals.

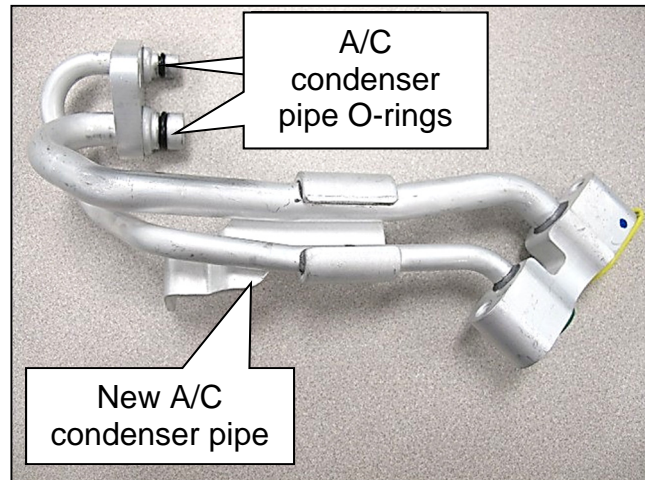

Figure 19

- d. Thread the new A/C condenser pipe through the radiator core support (Figure 20).
- e. Install the A/C condenser pipe into the engine compartment.
- f. Remove any caps and/or protective covering from the A/C condenser openings.

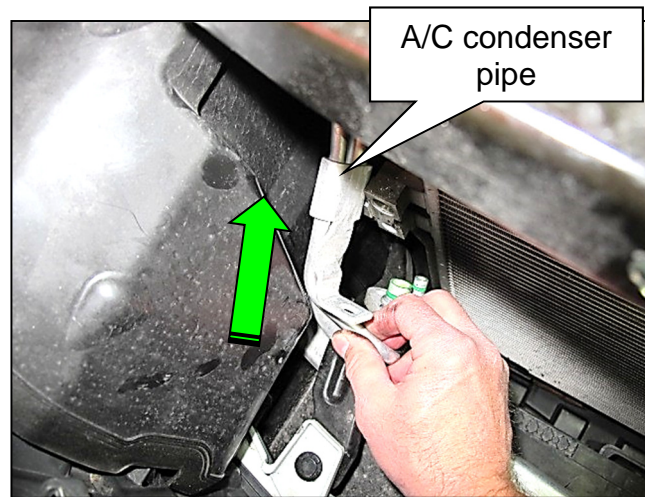

Figure 20

- g. Install and torque the two (2) 10 mm A/C condenser pipe retaining bolts (Figure 21).
 - o A/C condenser pipe retaining bolt torque: 8.0 N•m (0.82 kg-m, **71 in-lb**)

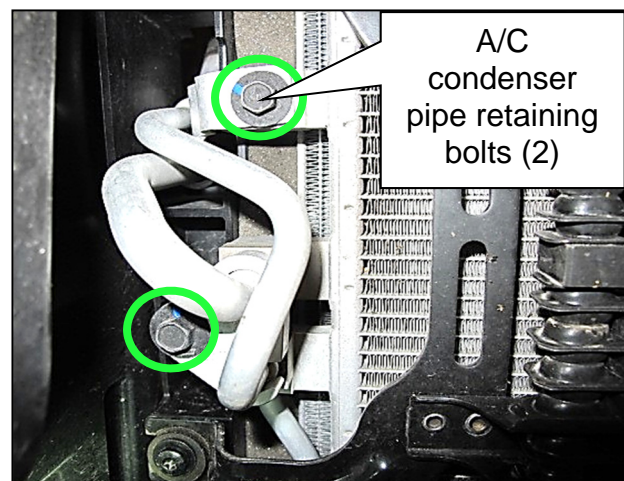

Figure 21

17. Install the high pressure pipe and the high pressure flex-hose connections.
 - a. Remove any caps and/or protective covering from the A/C high pressure pipe and the high pressure flex-hose connections.
 - b. Install new O-rings and captured seals onto the high pressure pipe and the high pressure flex-hose connections (Figure 22).
 - c. Apply the correct refrigerant oil (PAG VC100YF) to the new high pressure pipe and high pressure flex hose O-rings and captured seals.

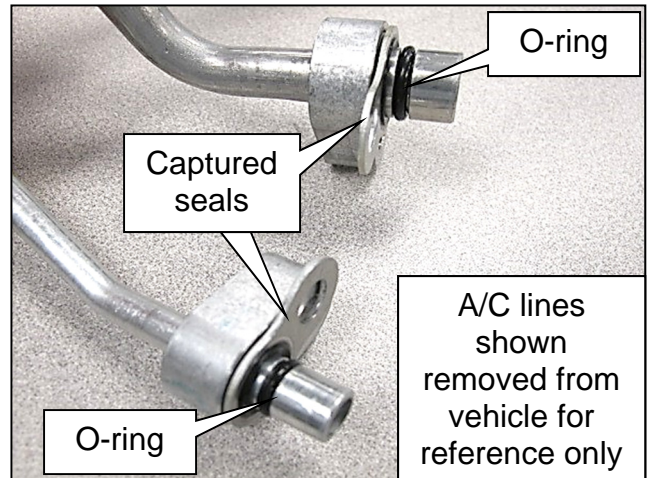

Figure 22

- d. Connect the high pressure pipe and the high pressure flex-hose connections (Figure 23).
- e. Install and torque the two (2) 12 mm retaining bolts for the high pressure pipe and the high pressure flex-hose connections.
 - o High pressure pipe and high pressure flex-hose connection bolt torque: 11.0 N•m (1.1 kg-m, **8 ft-lb**)

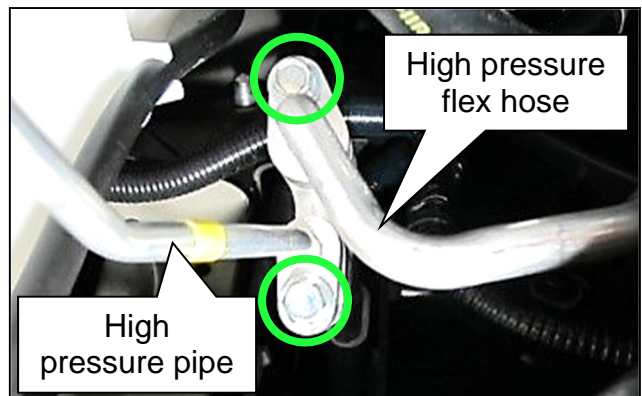

Figure 23

18. Install a new front bumper energy absorber with the one listed in **PARTS INFORMATION** on the last page.

a. The front bumper energy absorber is directional. Install it with the "R1" and arrow facing up (Figure 24 and Figure 25).



Figure 24

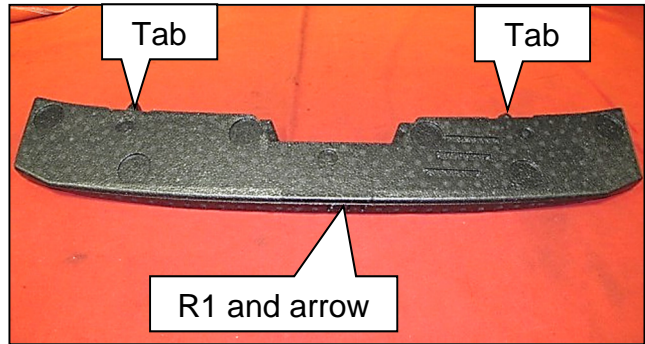

Figure 25

b. Locate the two (2) retaining tabs on the back of the front bumper energy absorber and gently install them into the radiator core support holes (Figure 26).

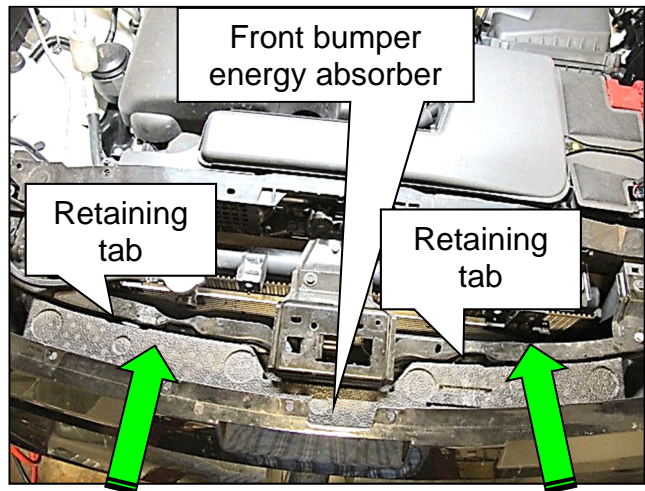

Figure 26

19. Reposition the top right and left sides of the front grille (Figure 27).

- a. Push down on the top corners of the front grille to align the retaining clips on the sides into the respective holes, then latch the front grille into place.

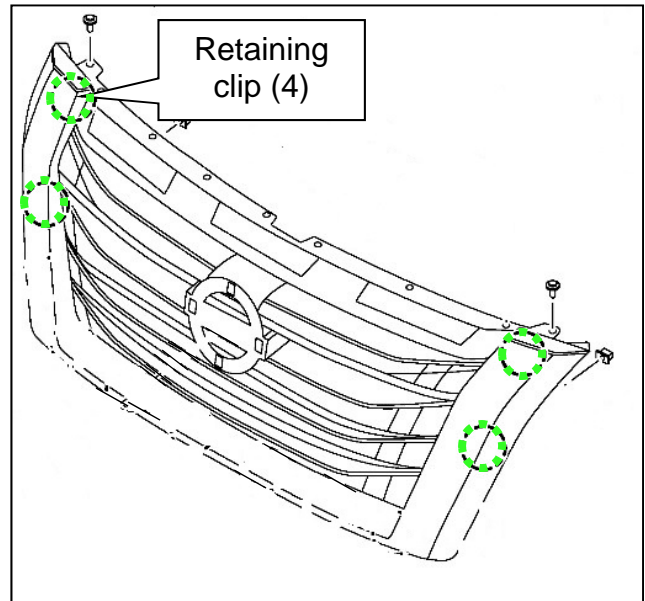

Figure 27

- b. Install the top passenger (RH) side and the top driver (LH) side front grille retainer clips (Figure 28).

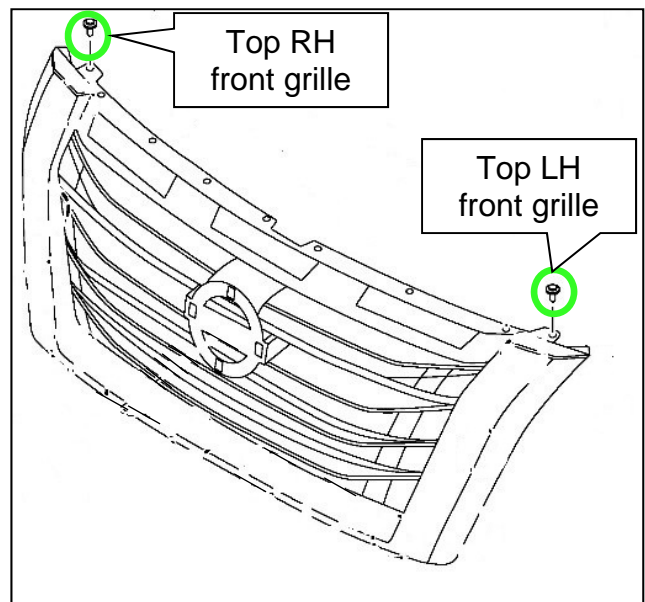

Figure 28

20. Install the splash guard (Figure 29).
- Install the three (3) retaining clips and the splash guard.

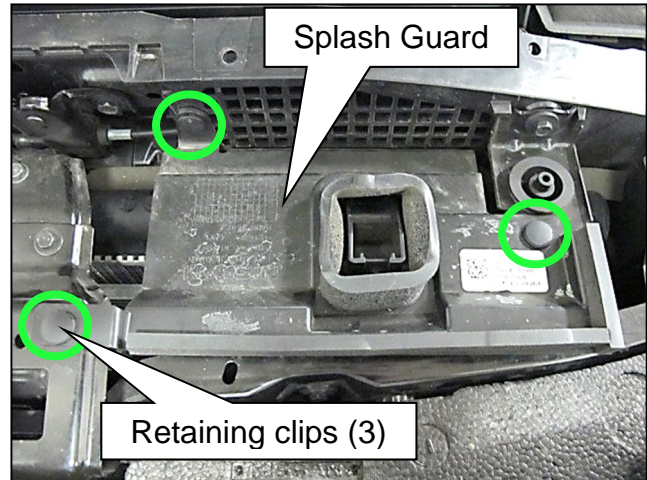

Figure 29

21. Install the core support cover, and then install the thirteen (13) core support cover retaining clips (Figure 30).

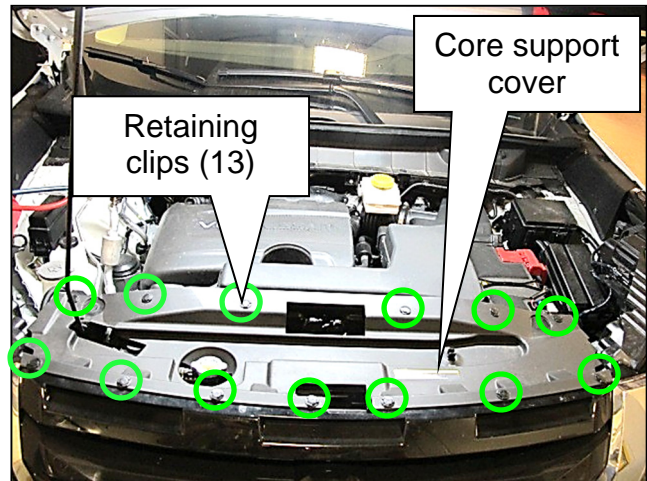

Figure 30

22. Recharge the refrigerant using approved equipment.
- Refer to the **ESM: VENTILATION, HEATER & AIR CONDITIONER > HEATER & AIR CONDITIONING SYSTEM > PERIODIC MAINTENANCE > REFRIGERANT > Charge Refrigerant**
 - Verify there are no refrigerant leaks at the condenser pipe connections.



Figure 31

23. Verify the A/C system is operating normally.
 - a. Set the parking brake.
 - b. Start the engine and turn on the climate control system to full cold.
 - c. Verify the cold air is blowing from the center vents.

24. Remove the protective fender cover.

25. Close the hood.

PARTS INFORMATION

DESCRIPTION	PART NUMBER	QUANTITY
PIPE ASSY	92446-6SA0K	1
SEAL O-RING	92471-N823A	1
SEAL O-RING	92472-N823A	1
SEAL O-RING	92477-6RR1A	1
SEAL O-RING	92477-6RR2A	1
FR BUMPER EA	62090-6TA0B	1

EXPENSE CODE

Submit a "CM" line claim using the following claims coding:

CODE #	DESCRIPTION	AMOUNT (MAX)
123	R1234yf A/C Refrigerant	\$104.75 (1)
124	PAG VC100YF Refrigerant Oil (2)	\$4.81 (3)

- (1) One (1) lb. maximum.
- (2) For new O-ring lubrication ONLY.
- (3) ½ ounce maximum.

CLAIMS INFORMATION

Submit a "CM" line claim using the following claims coding:

CAMPAIGN ("CM") ID	DESCRIPTION	OP CODE	FRT
PC899	Replace A/C Condenser Pipe	PC8990	1.3

AMENDMENT HISTORY

PUBLISHED DATE	REFERENCE	DESCRIPTION
July 22, 2022	NTB22-059	Original bulletin published