

# Service Journal

TITLE:

**Aftermarket Wiring Diagrams XC40 and C40 MY23**

<b>REF NO:</b> 1001522	<b>ISSUING DEPARTMENT:</b> Service Operations	<b>REVISIONS:</b>
<b>CATEGORY:</b>	<b>SUBCATEGORY:</b>	<b>CAR MARKET:</b> United States and Canada
<b>ISSUE DATE:</b> 2022-07-22	<b>STATUS DATE:</b> 2022-07-22	<b>Page 1 of 150</b>

**“Right first time in Time”**

As a result of delays in the production of aftermarket wiring diagrams, no wiring diagrams will be available in VIDA by start of production for MY23 CMA (2022 week 22).

Models included:

XC40 Battery Electric Vehicle, XC40 Non-Battery Electric Vehicle, C40

**Temporary Solution:**

Refer to system based wiring diagrams from R&D attached as a PDF.

**Final Solution**

Customer function based wiring diagrams will continuously be released to VIDA once they are finished.

# P319/V316/V317

## 622A\_PP | 623A\_VP | 624A\_E2

Sheet Name	Sheet Number	Sheet Name	Sheet Number
0A_P319_V316_V317	1	2R_Safety_Belt	76
0B1_Overview_LHD	2	2S_Restraint	77
0B2_Overview_RHD	3	3A_3C_Engine_management	78
1A1_Electrical_distribution_CJB_BEV	4	3A_3D_Engine_Management_(HEV)	79
1A1_Electrical_distribution_CJB_N_BEV	5	3A_3D_Engine_Management_VEP4_GEN3_(HEV)	80
1A1_Electrical_distribution_EJB_BEV	6	3A_Engine_Management_GEP3_(HEV)	81
1A1_Electrical_distribution_EJB_N_BEV	7	3A_Engine_Management_VEP4_G3_(N_BEV)	82
1A3_System_relays_control_BEV	8	3B_Management_BEV_Driveline	83
1A3_System_relays_control_HEV	9	3B_Management_Hybrid_Driveline_HEV	84
1B1_Grounding_Engine_Body	10	3D_Engine_thermal_management_BEV	85
1B2_Grounding_IP_Roof_Tunnel	11	3D_Engine_thermal_management_HEV	86
1B3_Grounding_Body_Front	12	3E_Automatic_Gear_Shifting	87
1B4_Grounding_Body_Rear_Tailgate	13	3E_Automatic_Gear_Shifting_7DCT	88
1C1_EI_power_generating	14	3G_4WD_Transmission	89
1D_Diagnostics	15	3H_Manual_Gear_Shifting	90
1E_CAN_ABS_Braking	16	3M_Engine_Cranking_Control_(HEV)	91
1E_CAN_Body	17	3S_Fuel_Supply_Control	92
1E_CAN_Body_Exp	18	4A_Driver_Information	93
1E_CAN_Chassie	19	4J1_Parking_Assistance_FAP	94
1E_CAN_Connectivity_Diagnostics	20	4J1_Parking_Assistance_NBEV	95
1E_CAN_Engine	21	4J1_Parking_Assistance_PAS_PAS2	96
1E_CAN_Front_1	22	4J2B_Lane_Change_Aid	97
1E_CAN_Front_3	23	4J4_PAC_Visualisation	98
1E_CAN_Front_Exposed	24	4J4_PAC_Visualisation/Driver_Assistance	99
1E_CAN_Mid_1	25	5A_Climate_Control	100
1E_CAN_Propulsion_1A_Front	26	5A_Climate_Control_HEV_PHEV	101
1E_CAN_Propulsion_1B_Front_Hybrid	27	5A_Climate_Control_HVAC_ECC	102
1E_CAN_Propulsion_2_Centre	28	5B_Front_Seat_Comfort	103
1E_CAN_Rear_1	29	5B_Front_Seat_Comfort_PHEV	104
1E_CAN_Safety_Exposed_BEV_48V_KERS	30	5B_Rear_Seat_Comfort	105
1E_CAN_Safety_Exposed_ICE_PHEV	31	5B_Rear_Seat_Comfort_PHEV	106
1E_CAN_Safety_Protected	32	5F1_Passenger_Compartment_Pre-Conditioning	107
1E_FlexRay_Backbone_BEV_48V_KERS	33	5G_Steering_Wheel_Heating	108
1E_FlexRay_Backbone_ICE_PHEV	34	6A_Locking	109
1E_FlexRay_Front_2	35	6A_Locking_Front_Right	110
1E_FlexRay_Mid_2	36	6A_Locking_Rear_Right	111
1E_LIN_Body	37	6C1_Phone_As_Key	112
1E_LIN_Body_Infotainment_Powertrain	38	6C_Theft_protection	113
1E_LIN_Comfort	39	6D_Window_Manoeuvring	114
1E_LIN_MOST	40	6D_Window_Manoeuvring_Right	115
1E_LIN_POWERTRAIN_N_BEV	41	6F_Roof_Manoeuvring	116
1F1_Accessories_Alcolock_Aftermarket	42	6K_Tailgate_and_boot_lid_manoeuvring_etc	117
1F1_Accessories_ALCPRP_TOWBAR	43	6P_Voltage_outlet	118
1F2_Accessories_Towing_System_4/7-pole_US	44	7A_External_Amplifier	119
1F3_Accessories_Rear_Park_Assist_Camera	45	7A_Infotainment	120
1F4_Accessories_LED_Illumination	46	7A_Infotainment_N_ICUP	121
1F4_Accessories_USB_Hub_Installation_Aftermarket	47	7A_Television	122
1F5_Accessories_Steering_Wheel_Heating	48	7B_Telematics_ICUP	123
1H1_EI_Distribution_High_Voltage_BEV	49	7B_Telematics_N_ICUP	124
1H2_EI_Distribution_High_Voltage_PHEV	50	7C_DSRC	125
1K1_EI_Energy_Management_High_Voltage_BEV	51	7C_DSRC_N_ICUP	126
1K2_EI_Energy_Management_High_Voltage_BEV_3X	52	7F_Electronic_Toll_Collection	127
1K3_EI_Energy_Management_High_Voltage_PHEV	53	8A_Exterior_Light_Front	128
1L1_EI_generating_public_network_1X	54	8A_Exterior_Light_LED_Front	129
1L2_EI_generating_public_network_2X	55	8A_Exterior_Light_Rear_V316	130
1L3_EI_generating_public_network_V331_3X-4X_DC	56	8A_Exterior_Light_Rear_V331_V317	131
1L4_EI_generating_public_network_V331_3X_AC	57	8K_8H_8J_Lamp_windscreen_rear_window_cleaning	132
1L5_EI_generating_public_network_V331_4X_AC	58	8K_8H_8J_Lamp_windscreen_rear_window_cleaning_NBEV	133
1L6_EI_generating_public_network_V316_V317_3X-4X_DC	59	8N_8L_Windscreen_rear_window_defroster	134
1L7_EI_generating_public_network_V316_V317_3X_AC	60	8P_Sound_signaling	135
1L8_EI_generating_public_network_V316_V317_4X_AC	61	9A_Interior_Lights	136
1L9_EI_generating_public_network_V316_PHEV	62	9A_Interior_Lights_Doors	137
1M_EI_Distribution_Mid_Voltage	63	9A_Interior_Lights_Doors_Right	138
2A_Braking	64	9H_Instr_Control_Switch_Lighting	139
2A_Braking_48V_KERS	65	10A_Driver_Seat_Internal_Harness_High_LHD	140
2A_Braking_F-TE	66	10A_Driver_Seat_Internal_Harness_High_RHD	141
2A_Braking_Hybrid	67	10A_Driver_Seat_Internal_Harness_Mech_LHD	142
2E2_Steering	68	10A_Driver_Seat_Internal_Harness_Mech_RHD	143
2E_Power_Steering	69	10A_Interior_HVAC_Harness_VCC_2-ZONES_ECC	144
2G_Levelling_control	70	10A_Internal_7DCT_Harness	145
2M_Pedestrian_Protection	71	10A_Passenger_Seat_Internal_Harness_High_LHD	146
2N_Safety_Belt_Reminder	72	10A_Passenger_Seat_Internal_Harness_High_RHD	147
2O_Collision_Avoidance	73	10A_Passenger_Seat_Internal_Harness_Mech_LHD	148
2P_Supplementary_Restraint_System_Igniters_BEV	74	10A_Passenger_Seat_Internal_Harness_Mech_RHD	149
2P_Supplementary_Restraint_System_Igniters_HEV_PHEV	75		

<p>The copying, distribution and utilization of this document as well as the communication of its contents to others without expressed authorization is prohibited. Offenders will be held liable for payment of damages. All rights reserved in the event of the grant of a patent, utility model or ornamental design registration.</p>  <p>VOLVO CAR CORPORATION</p>	<b>Document title</b> CMA_622A_CC_All_5_30 0A_P319_V316_V317	
	<b>Document Type</b> DRAW/ELSY	<b>Release Status</b> RELEASED
	Volvo Document No 33445458	<b>Edited</b> February/15/2022
	<b>Issue</b> 030	<b>Page No</b> 1/149

# 0B Overview LHD

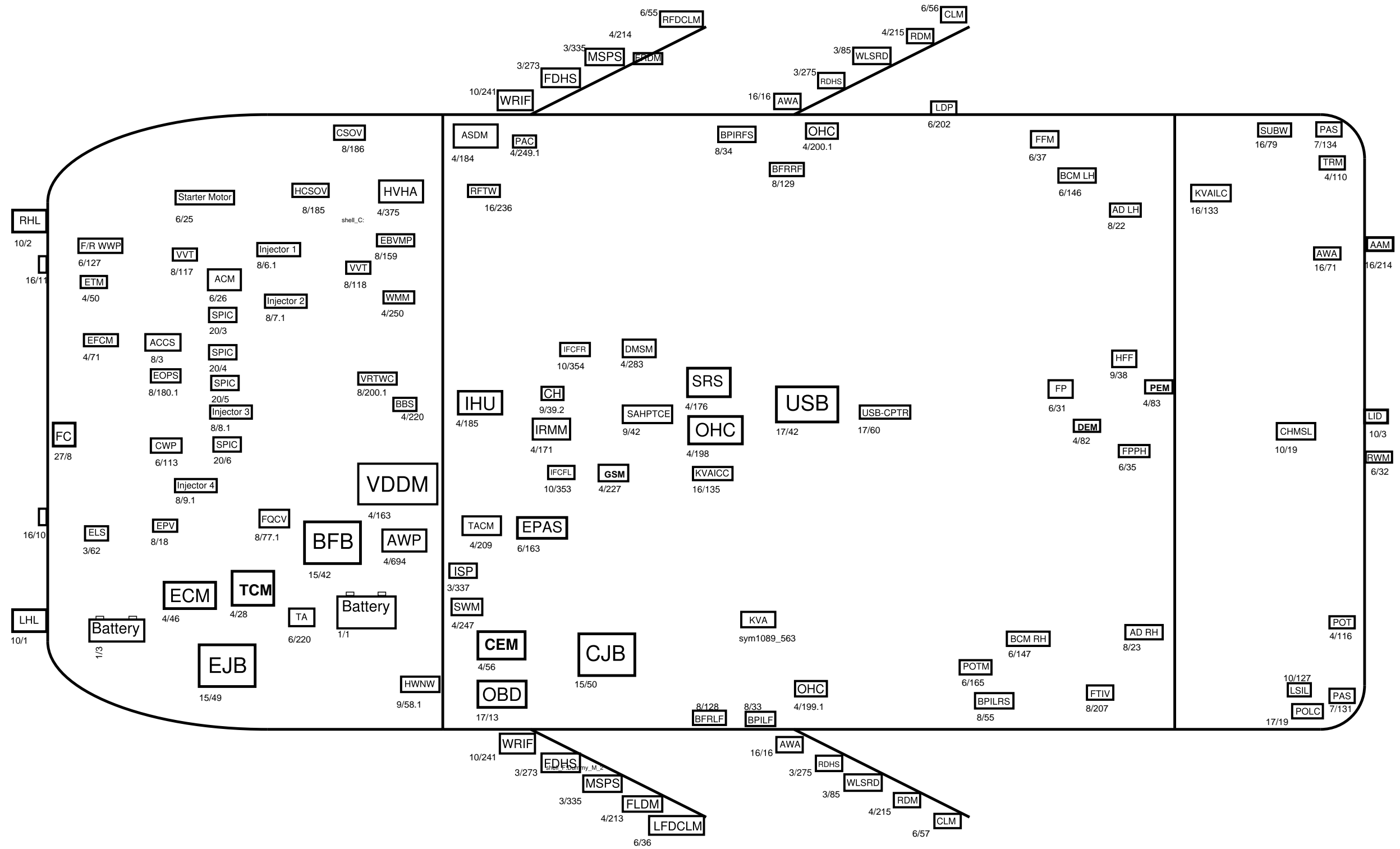

shell\_C1:30682003  
 shell\_H1:32200089  
 shell\_O1:30731581

<p>The copying, distribution and utilization of this document as well as the communication of its contents to others without expressed authorization is prohibited. Offenders will be held liable for payment of damages. All rights reserved in the event of the grant of a patent, utility model or ornamental design registration.</p> <p><b>VOLVO</b> VOLVO CAR CORPORATION</p>	<b>Document title</b> CMA_622A_CC_All_5_30	
	0B1_Overview_LHD	
	<b>Document Type</b> DRAW/ELSY	<b>Release Status</b> RELEASED
	Volvo Document No 33445458	<b>Edited</b> September/23/2020
<b>Issue</b> 030	<b>Page No</b> 2/149	

# 0B Overview RHD

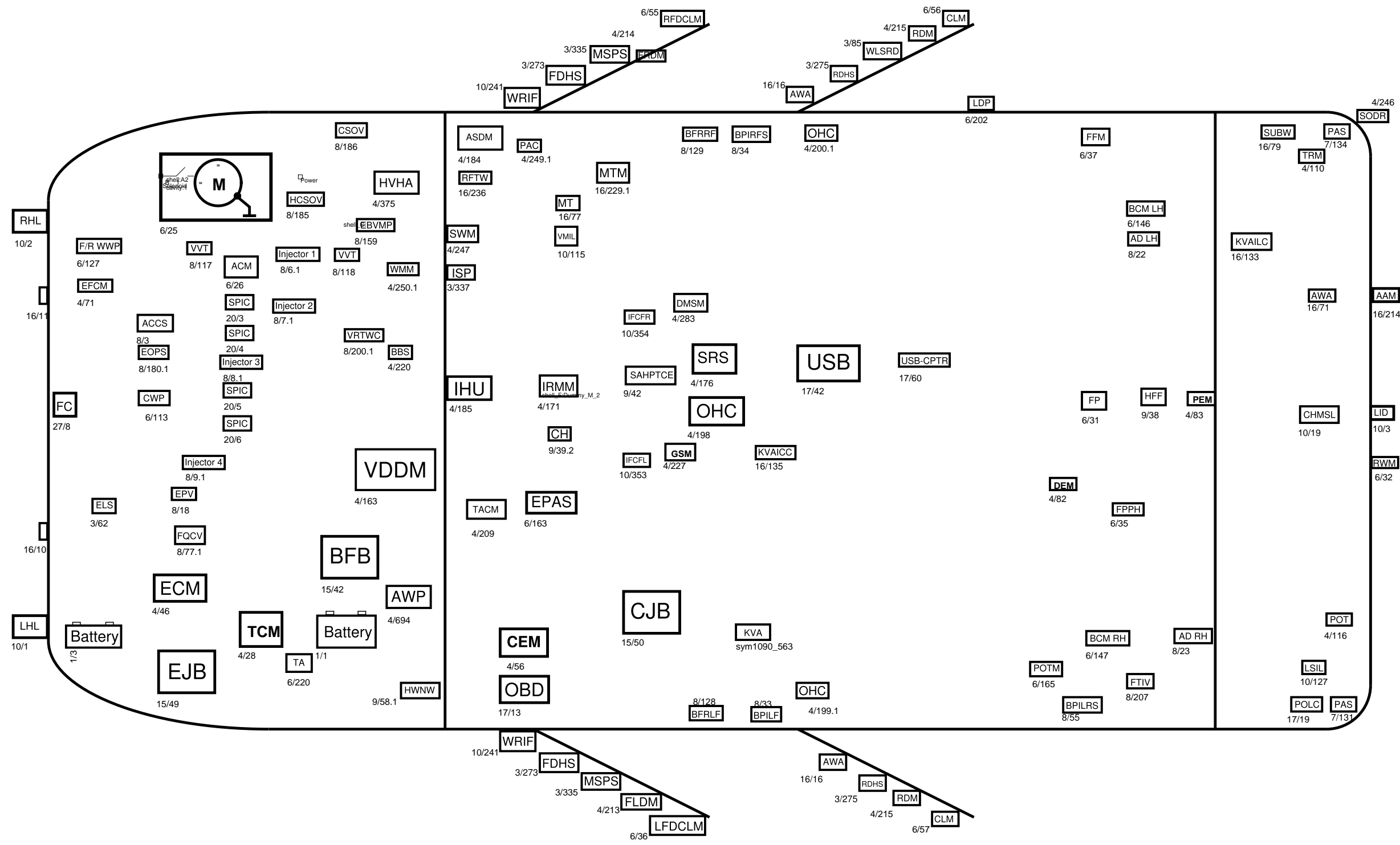

shell\_C1:30682803  
 shell\_H1:32200089  
 shell\_O1:30731581

<p>The copying, distribution and utilization of this document as well as the communication of its contents to others without expressed authorization is prohibited. Offenders will be held liable for payment of damages. All rights reserved in the event of the grant of a patent, utility model or ornamental design registration.</p> <p><b>VOLVO</b> VOLVO CAR CORPORATION</p>	<p><b>Document title</b> CMA_622A_CC_All_5_30 0B2_Overview_RHD</p>	
	<p><b>Document Type</b> DRAW/ELSY</p>	<p><b>Release Status</b> RELEASED</p>
	<p>Volvo Document No 33445458</p>	<p><b>Edited</b> November/03/2020</p>
	<p><b>Issue</b> 030</p>	<p><b>Page No</b> 3/149</p>

# 1A1 Electrical distribution CJB BEV

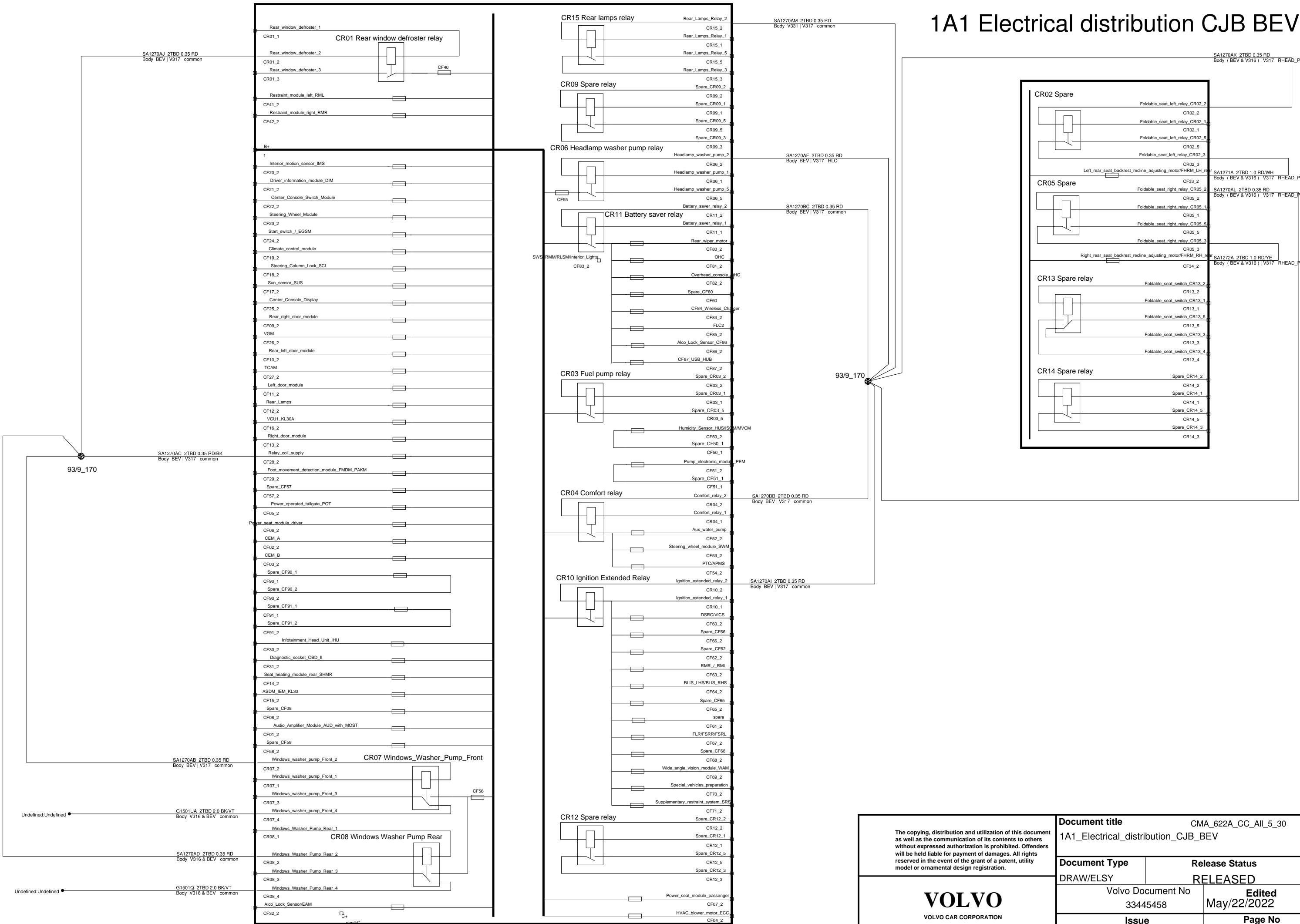

<p>The copying, distribution and utilization of this document as well as the communication of its contents to others without expressed authorization is prohibited. Offenders will be held liable for payment of damages. All rights reserved in the event of the grant of a patent, utility model or ornamental design registration.</p>		<p><b>Document title</b> CMA_622A_CC_All_5_30</p> <p>1A1_Electrical_distribution_CJB_BEV</p>	
		<p><b>Document Type</b> DRAW/ELSY</p>	<p><b>Release Status</b> RELEASED</p>
<p><b>VOLVO</b> VOLVO CAR CORPORATION</p>		<p>Volvo Document No 33445458</p>	<p><b>Edited</b> May/22/2022</p>
		<p><b>Issue</b> 030</p>	<p><b>Page No</b> 4/149</p>

# 1A1\_Electrical\_distribution\_CJB\_N\_BEV

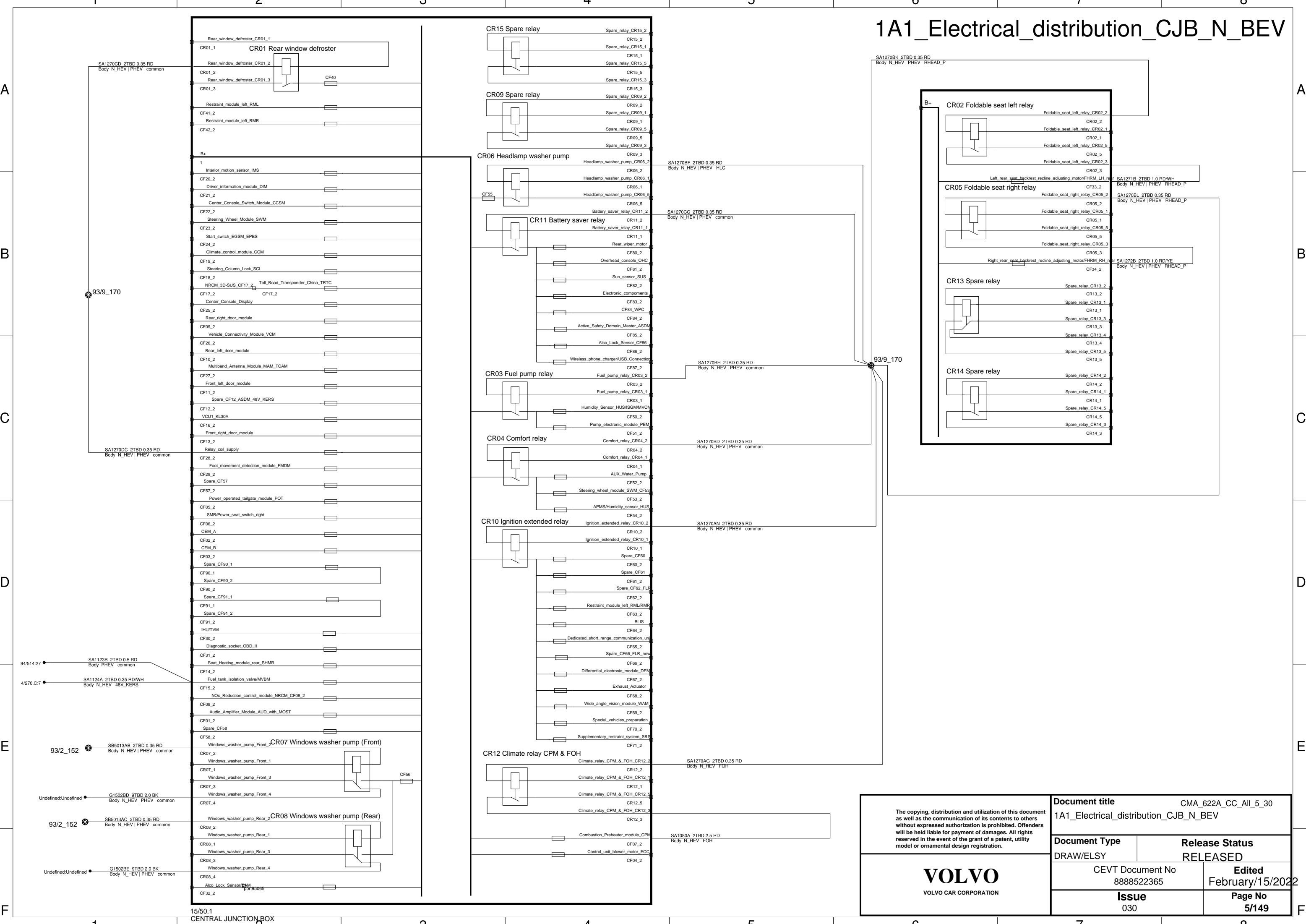

<p>The copying, distribution and utilization of this document as well as the communication of its contents to others without expressed authorization is prohibited. Offenders will be held liable for payment of damages. All rights reserved in the event of the grant of a patent, utility model or ornamental design registration.</p>		<b>Document title</b> CMA_622A_CC_All_5_30 1A1_Electrical_distribution_CJB_N_BEV	
		<b>Document Type</b> DRAW/ELSY	<b>Release Status</b> RELEASED
<p><b>VOLVO</b> VOLVO CAR CORPORATION</p>		CEVT Document No 8888522365	<b>Edited</b> February/15/2022
		<b>Issue</b> 030	<b>Page No</b> 5/149

# 1A1 Electrical distribution EJB BEV

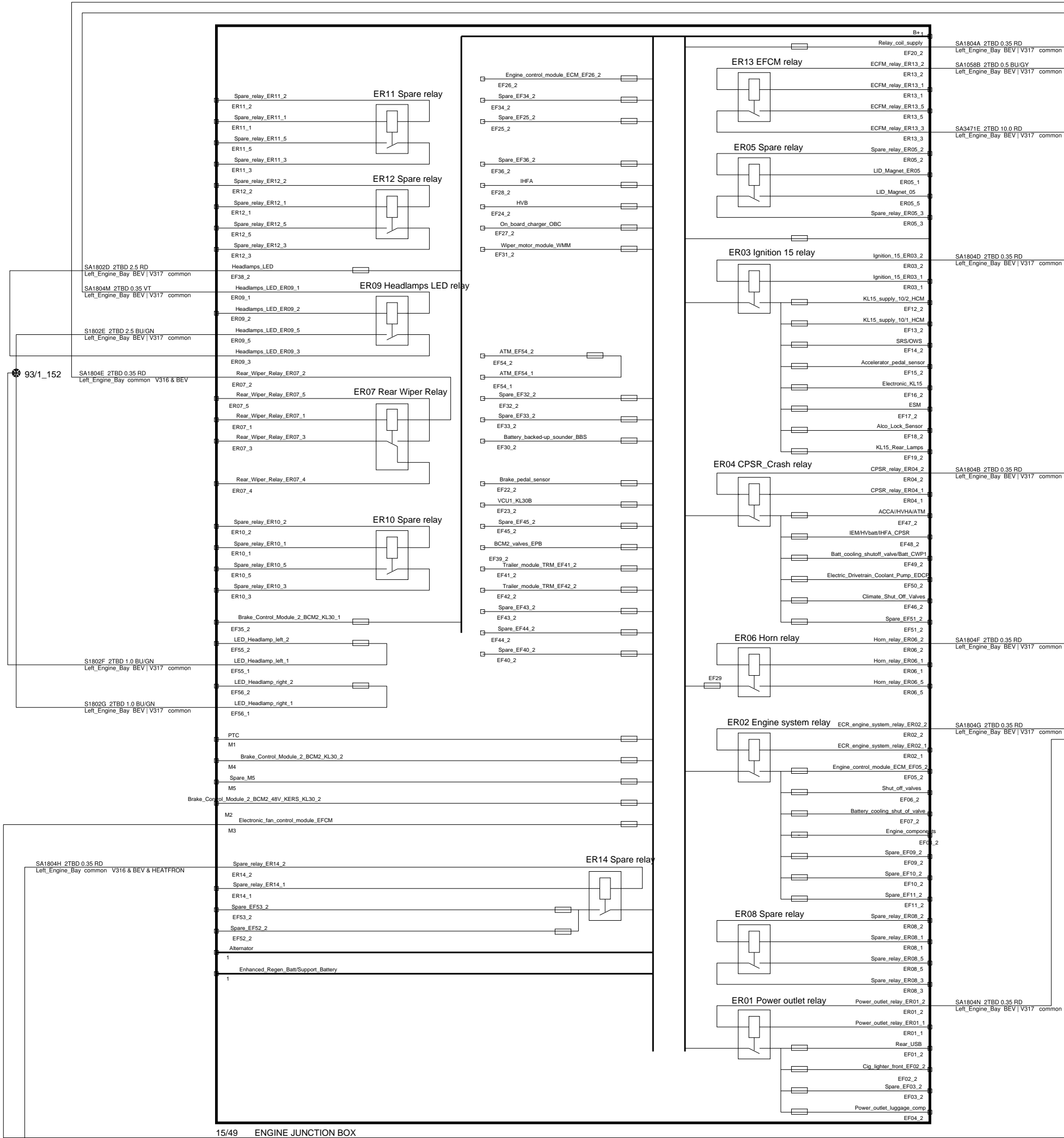

<p>The copying, distribution and utilization of this document as well as the communication of its contents to others without expressed authorization is prohibited. Offenders will be held liable for payment of damages. All rights reserved in the event of the grant of a patent, utility model or ornamental design registration.</p>		<b>Document title</b> CMA_622A_CC_All_5_30	
		1A1_Electrical_distribution_EJB_BEV	
<b>Document Type</b> DRAW/ELSY		<b>Release Status</b> RELEASED	
Volvo Document No 33445458		<b>Edited</b> January/20/2022	
<b>Issue</b> 030		<b>Page No</b> 6/149	



# 1A1\_Electrical\_distribution\_EJB\_N\_BEV

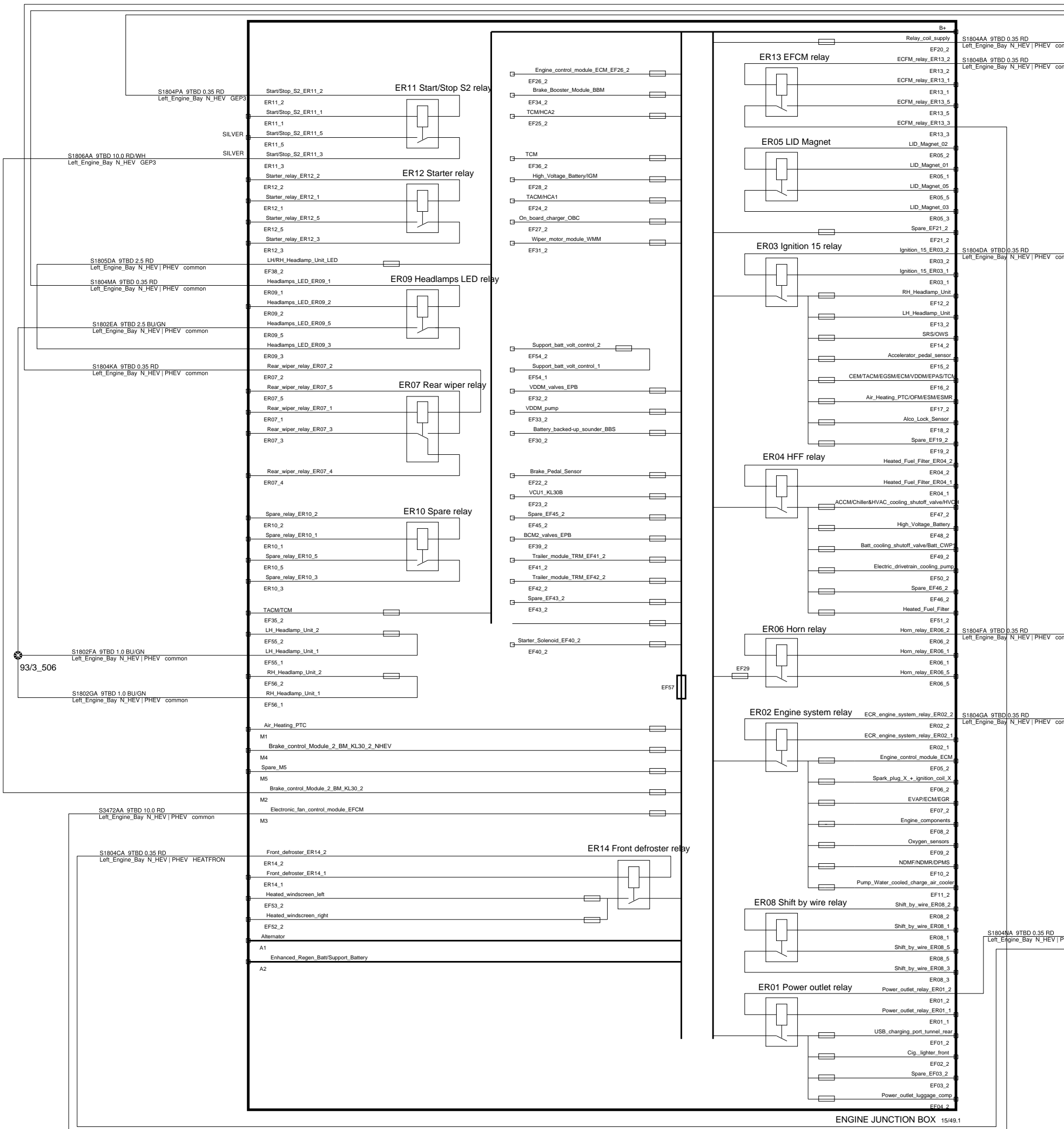

<p>The copying, distribution and utilization of this document as well as the communication of its contents to others without expressed authorization is prohibited. Offenders will be held liable for payment of damages. All rights reserved in the event of the grant of a patent, utility model or ornamental design registration.</p>		<b>Document title</b> CMA_622A_CC_All_5_30 1A1_Electrical_distribution_EJB_N_BEV	
		<b>Document Type</b> DRAW/ELSY	<b>Release Status</b> RELEASED
 <p>VOLVO CAR CORPORATION</p>		CEVT Document No 8888522365	Edited May/22/2022
		<b>Issue</b> 030	Page No 7/149



# 1A3 System relays control

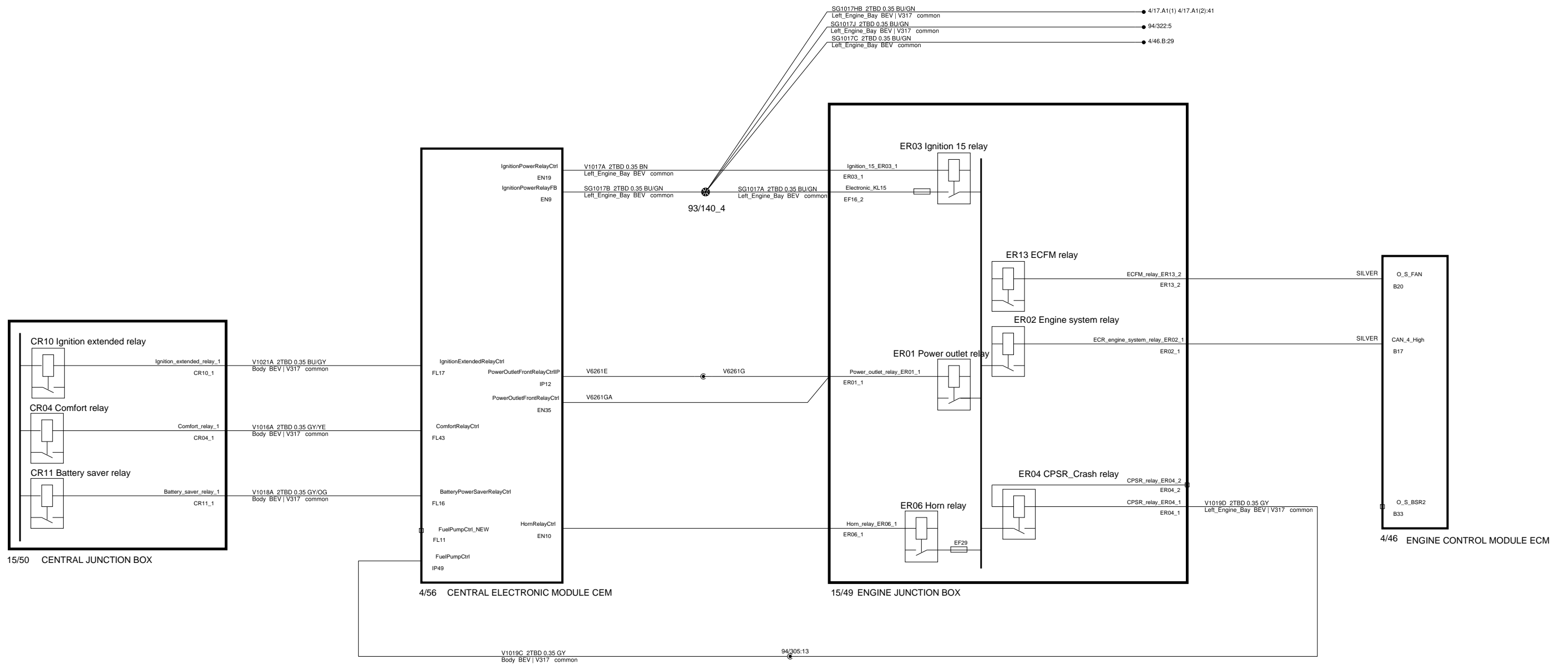

<p>The copying, distribution and utilization of this document as well as the communication of its contents to others without expressed authorization is prohibited. Offenders will be held liable for payment of damages. All rights reserved in the event of the grant of a patent, utility model or ornamental design registration.</p> <p><b>VOLVO</b> VOLVO CAR CORPORATION</p>	<b>Document title</b> CMA_622A_CC_All_5_30 1A3_System_relays_control_BEV	
	<b>Document Type</b> DRAW/ELSY	<b>Release Status</b> RELEASED
	Volvo Document No 33445458	<b>Edited</b> February/15/2022
	<b>Issue</b> 030	<b>Page No</b> 8/149

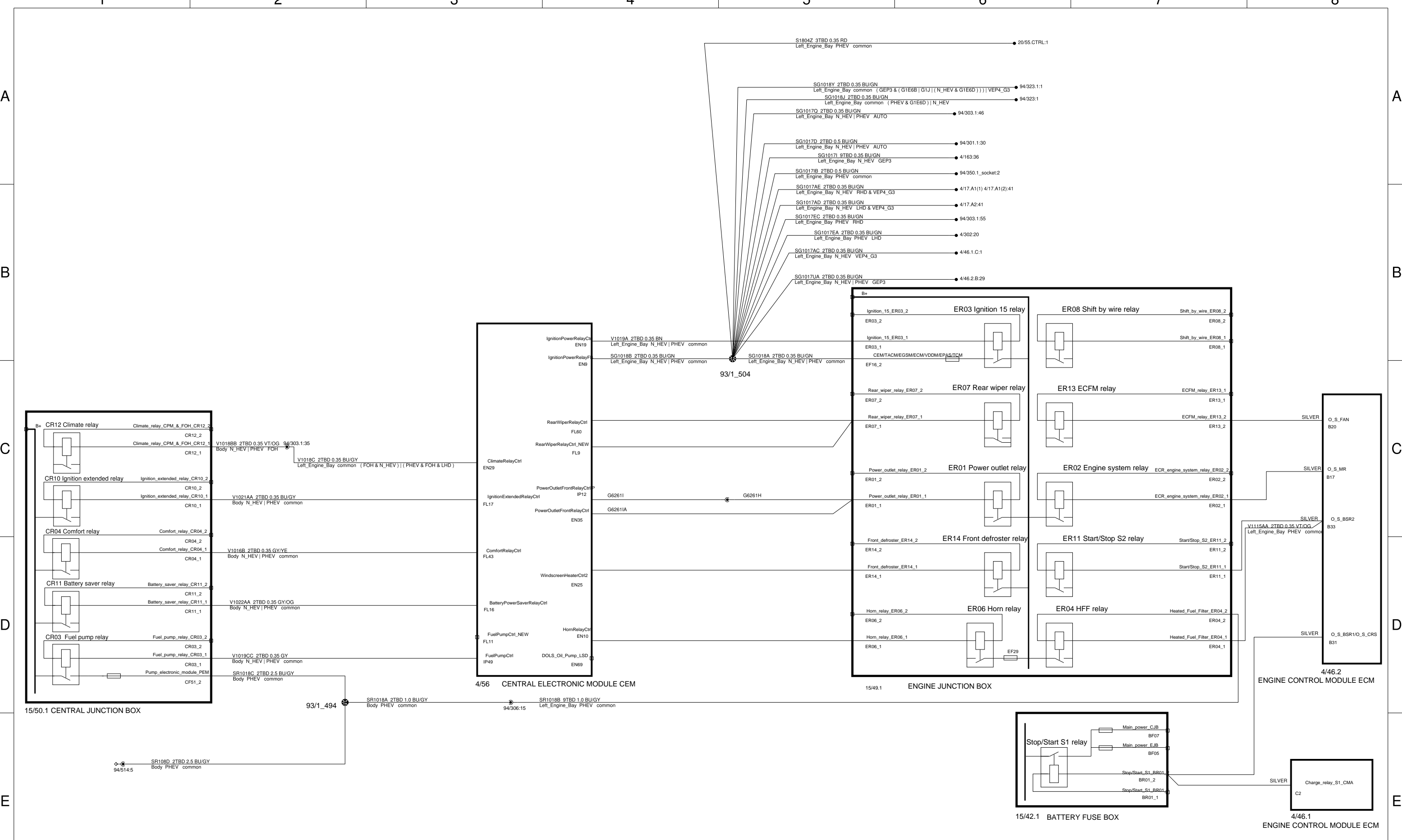

<p>The copying, distribution and utilization of this document as well as the communication of its contents to others without expressed authorization is prohibited. Offenders will be held liable for payment of damages. All rights reserved in the event of the grant of a patent, utility model or ornamental design registration.</p> <p><b>VOLVO</b> VOLVO CAR CORPORATION</p>	<b>Document title</b> CMA_622A_CC_All_5_30 1A3_System_relays_control_HEV	
	<b>Document Type</b> DRAW/ELSY	<b>Release Status</b> RELEASED
	CEVT Document No 8888522365	<b>Edited</b> May/22/2022
	<b>Issue</b> 030	<b>Page No</b> 9/149

# 1B Grounding Engine, Body

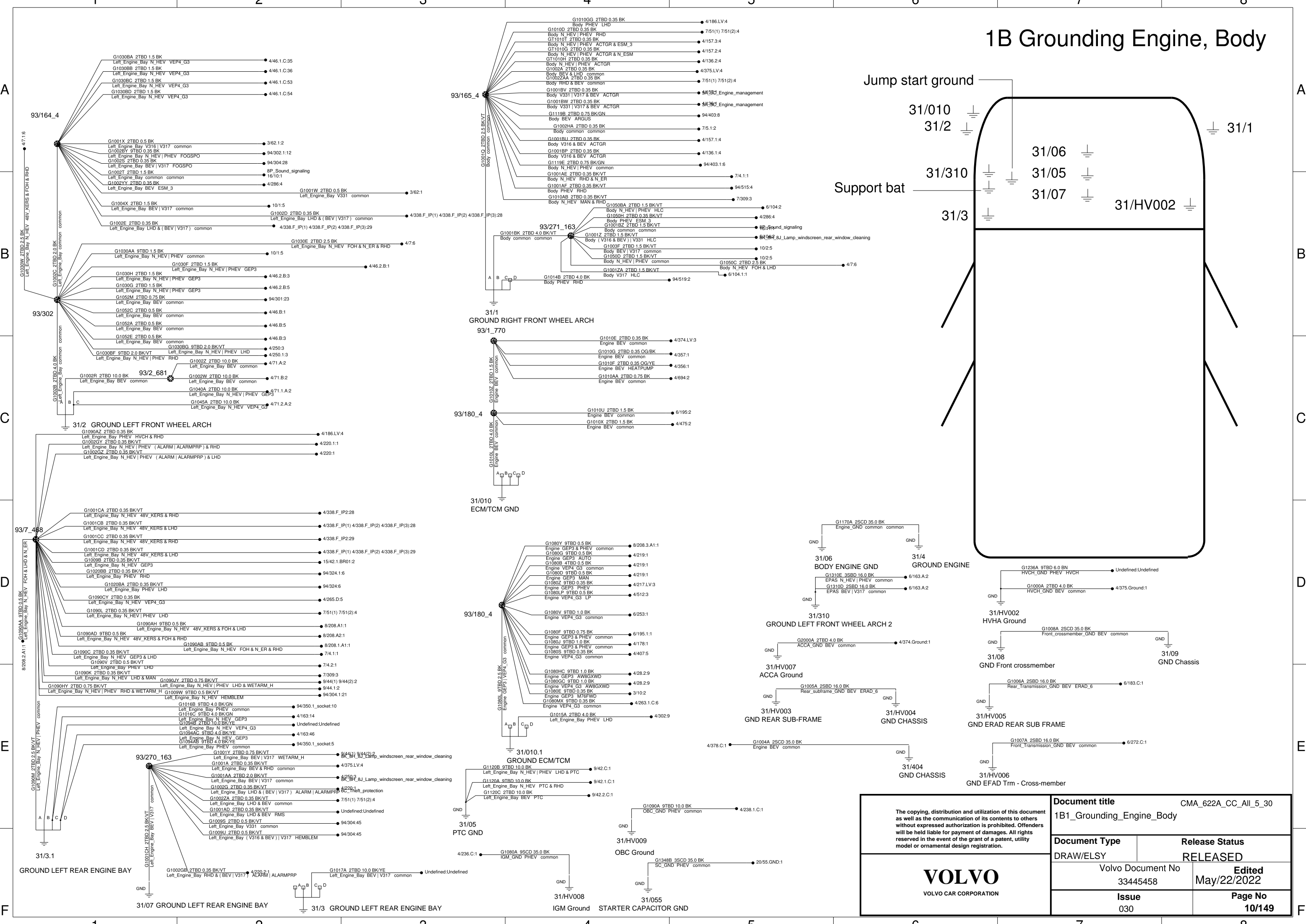

The copying, distribution and utilization of this document as well as the communication of its contents to others without expressed authorization is prohibited. Offenders will be held liable for payment of damages. All rights reserved in the event of the grant of a patent, utility model or ornamental design registration.

**VOLVO**  
VOLVO CAR CORPORATION

<b>Document title</b>		CMA_622A_CC_All_5_30	
<b>Document Type</b>		<b>Release Status</b>	
DRAW/ELSY		RELEASED	
Volvo Document No		<b>Edited</b>	
33445458		May/22/2022	
<b>Issue</b>		<b>Page No</b>	
030		10/149	

# 1B Grounding IP, Tunnel & Roof

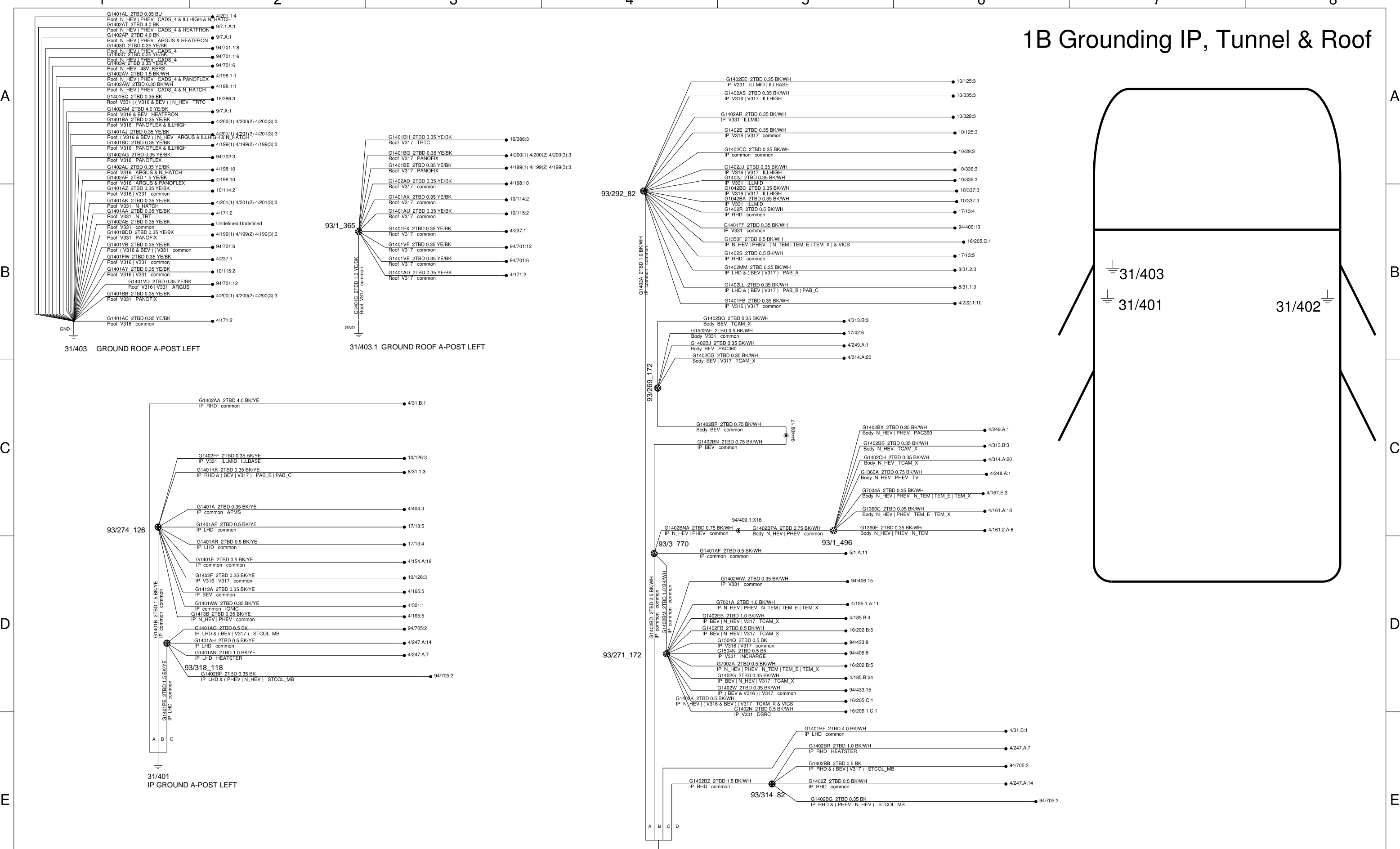

<p>The copying, distribution and utilization of this document as well as the communication of its contents to others without expressed authorization is prohibited. Offenders will be held liable for payment of damages. All rights reserved in the event of the grant of a patent, utility model or ornamental design registration.</p> <p><b>VOLVO</b> VOLVO CAR CORPORATION</p>		<b>Document title</b> CMA_622A_CC_All_5_30 1B2_Grounding_IP_Roof_Tunnel	
		<b>Document Type</b> DRAW/ELSY	<b>Release Status</b> RELEASED
Volvo Document No 33445458		<b>Edited</b> February/22/2022	
<b>Issue</b> 030		<b>Page No</b> 11/149	

# 1B Grounding Body Front

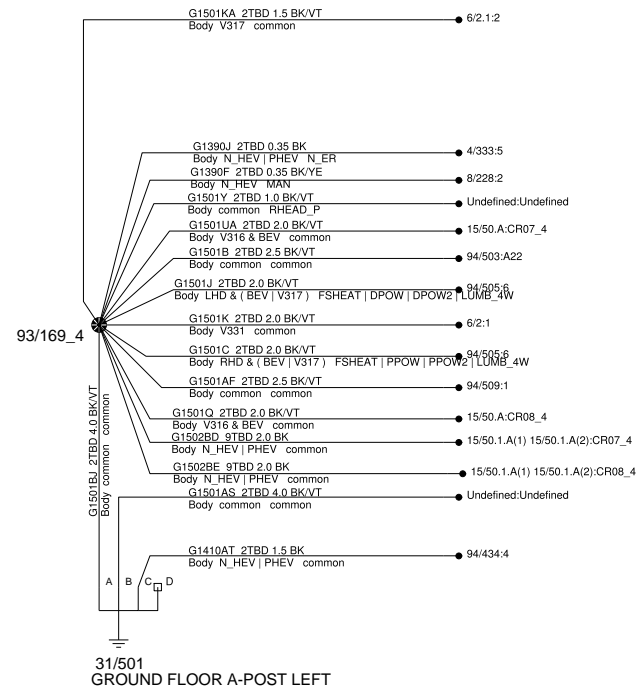

31/501  
GROUND FLOOR A-POST LEFT

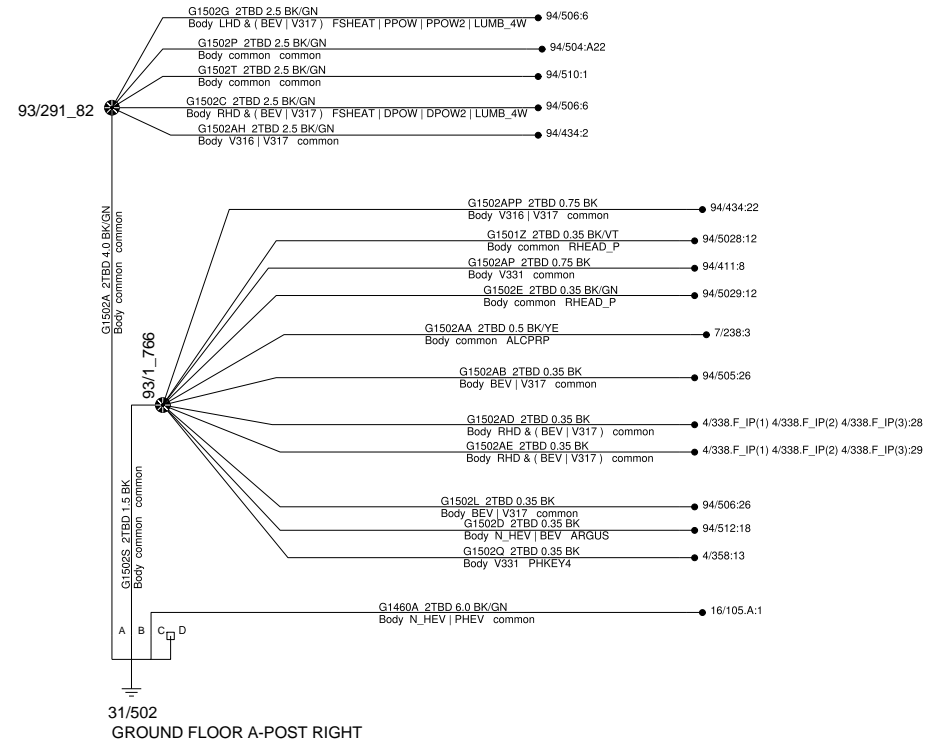

31/502  
GROUND FLOOR A-POST RIGHT

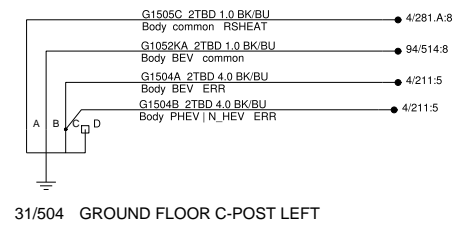

31/504  
GROUND FLOOR C-POST LEFT

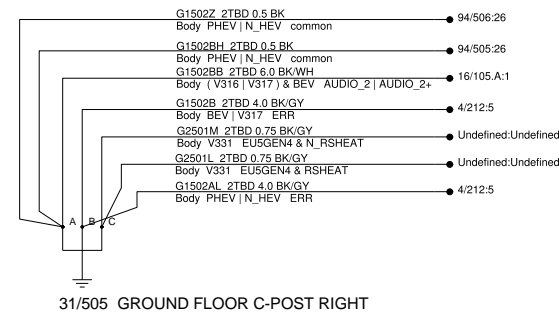

31/505  
GROUND FLOOR C-POST RIGHT

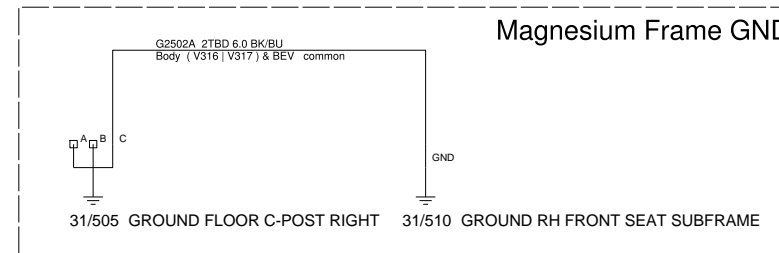

Magnesium Frame GND

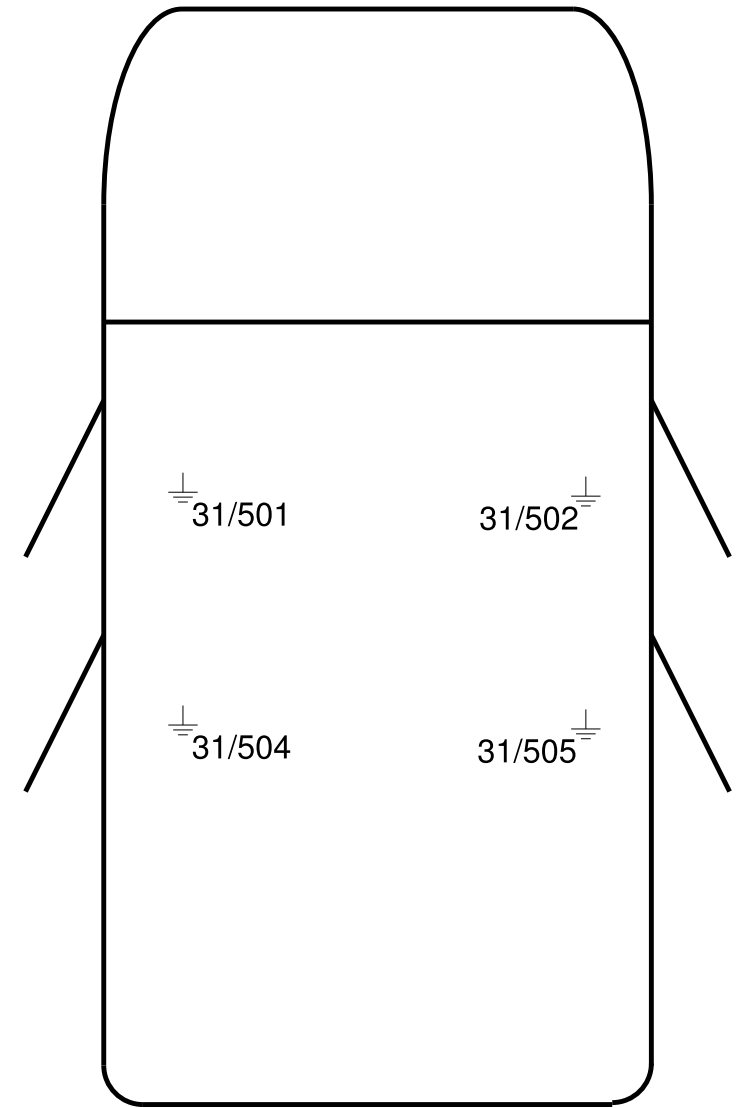

The copying, distribution and utilization of this document as well as the communication of its contents to others without expressed authorization is prohibited. Offenders will be held liable for payment of damages. All rights reserved in the event of the grant of a patent, utility model or ornamental design registration.

**VOLVO**  
VOLVO CAR CORPORATION

**Document title** CMA\_622A\_CC\_All\_5\_30  
1B3\_Grounding\_Body\_Front

**Document Type** DRAW/ELSY  
**Release Status** RELEASED

Volvo Document No 33445458  
**Edited** March/04/2022

**Issue** 030  
**Page No** 12/149

# 1B Grounding Body Rear, Tailgate

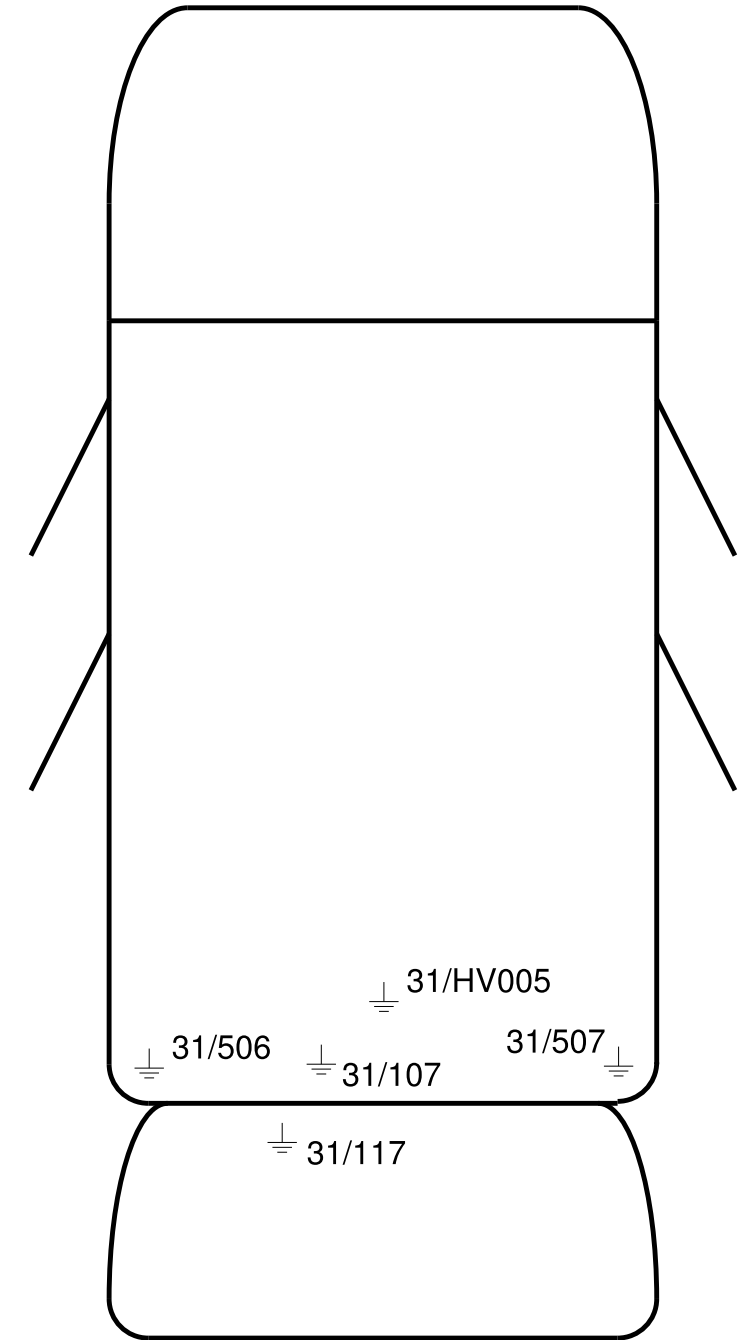
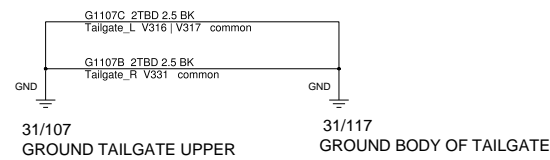
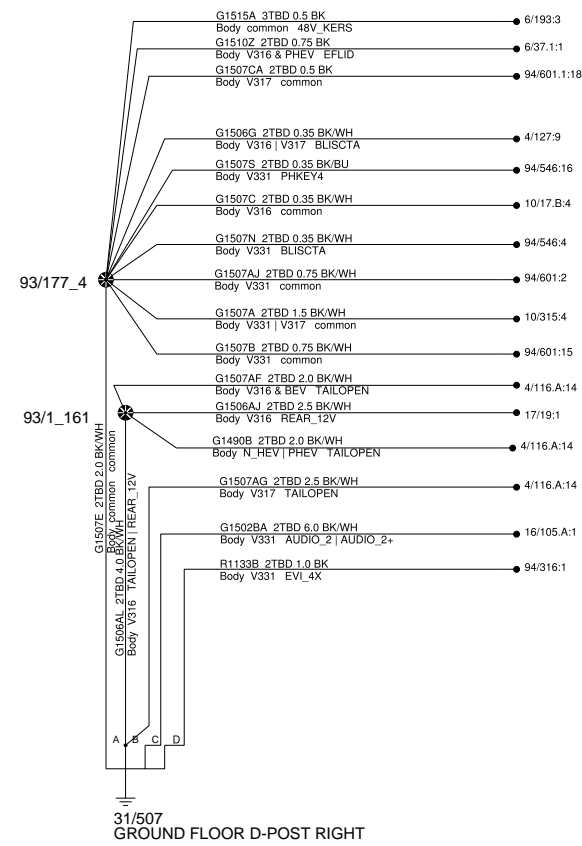
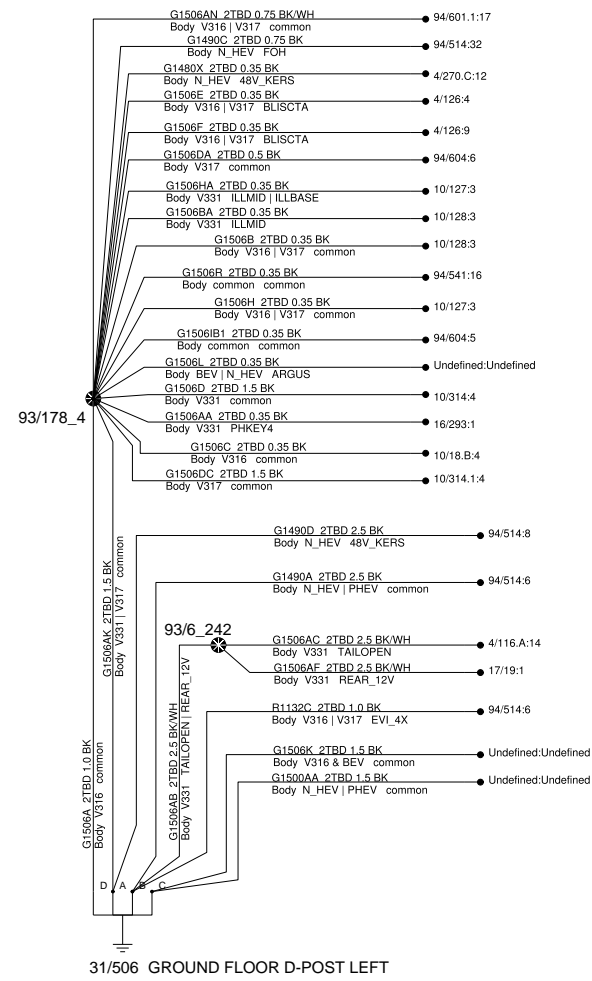

<p>The copying, distribution and utilization of this document as well as the communication of its contents to others without expressed authorization is prohibited. Offenders will be held liable for payment of damages. All rights reserved in the event of the grant of a patent, utility model or ornamental design registration.</p> <p><b>VOLVO</b> VOLVO CAR CORPORATION</p>	<b>Document title</b> CMA_622A_CC_All_5_30 1B4_Grounding_Body_Rear_Tailgate	
	<b>Document Type</b> DRAW/ELSY	<b>Release Status</b> RELEASED
	Volvo Document No 33445458	<b>Edited</b> March/18/2022
	<b>Issue</b> 030	<b>Page No</b> 13/149

# 1C1 El. Power generating

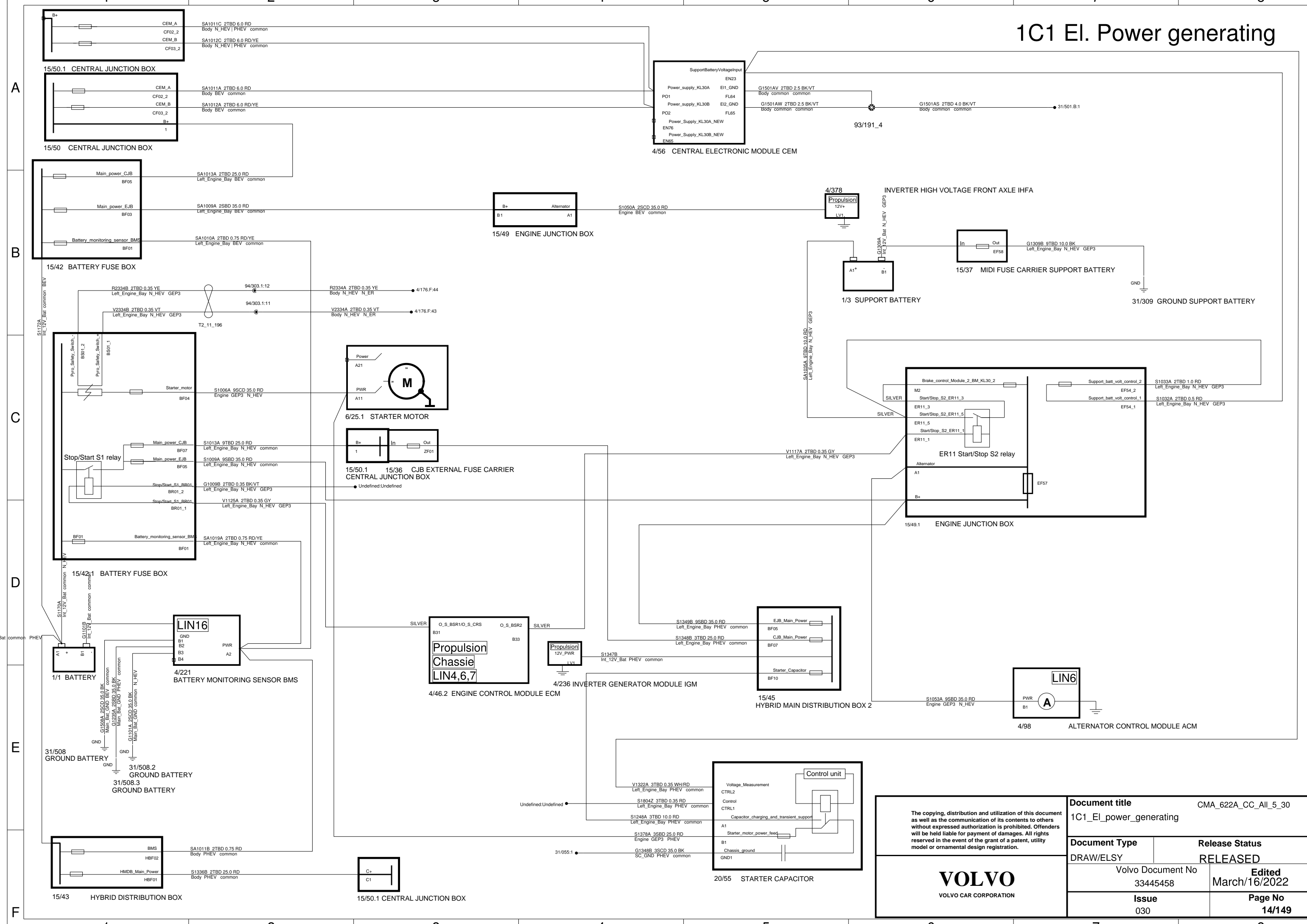

<p>The copying, distribution and utilization of this document as well as the communication of its contents to others without expressed authorization is prohibited. Offenders will be held liable for payment of damages. All rights reserved in the event of the grant of a patent, utility model or ornamental design registration.</p>		<p><b>Document title</b> CMA_622A_CC_All_5_30 1C1_El_power_generating</p>	
<p><b>Document Type</b> DRAW/ELSY</p>		<p><b>Release Status</b> RELEASED</p>	
<p><b>Issue</b> 030</p>		<p>Volvo Document No 33445458 <b>Edited</b> March/16/2022 <b>Page No</b> 14/149</p>	
<p><b>VOLVO</b> VOLVO CAR CORPORATION</p>			

# 1D Diagnostics



The copying, distribution and utilization of this document as well as the communication of its contents to others without expressed authorization is prohibited. Offenders will be held liable for payment of damages. All rights reserved in the event of the grant of a patent, utility model or ornamental design registration.

**VOLVO**  
VOLVO CAR CORPORATION

<b>Document title</b> 1D_Diagnostics		CMA_622A_CC_All_5_30	
<b>Document Type</b> DRAW/ELSY	<b>Release Status</b> RELEASED		
Volvo Document No 33445458		<b>Edited</b> June/16/2021	
<b>Issue</b> 030		<b>Page No</b> 15/149	



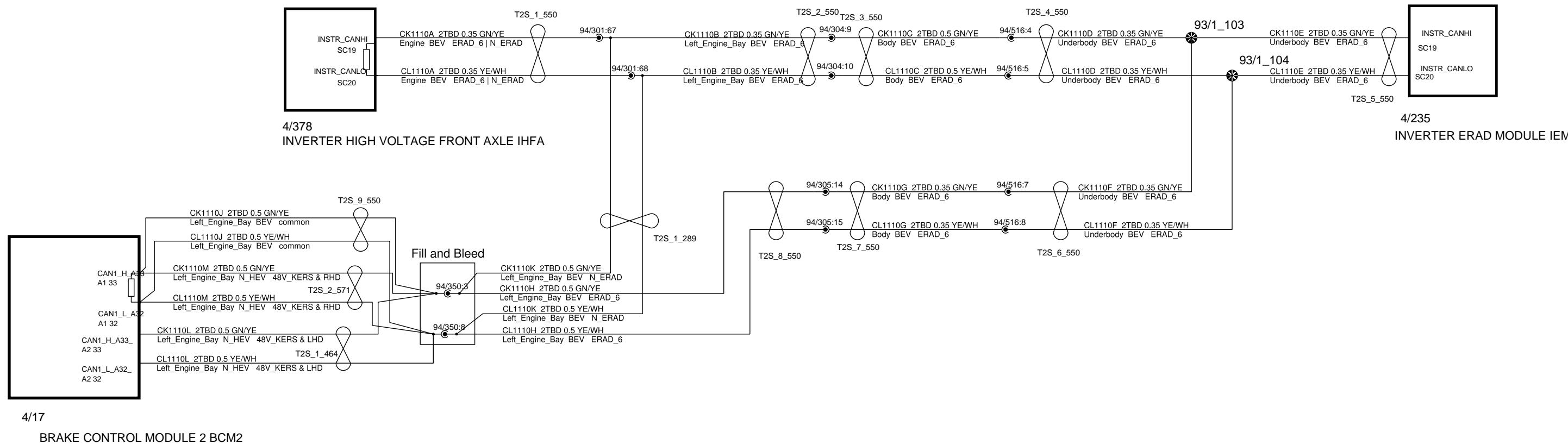

<p>The copying, distribution and utilization of this document as well as the communication of its contents to others without expressed authorization is prohibited. Offenders will be held liable for payment of damages. All rights reserved in the event of the grant of a patent, utility model or ornamental design registration.</p> <p><b>VOLVO</b> VOLVO CAR CORPORATION</p>	<p><b>Document title</b> CMA_622A_CC_All_5_30 1E_CAN_ABS_Braking</p>	
	<p><b>Document Type</b> DRAW/ELSY</p>	<p><b>Release Status</b> RELEASED</p>
	<p>CEVT Document No 8888522365</p>	<p><b>Edited</b> February/16/2022</p>
	<p><b>Issue</b> 030</p>	<p><b>Page No</b> 16/149</p>

# 1E Body CAN Exp

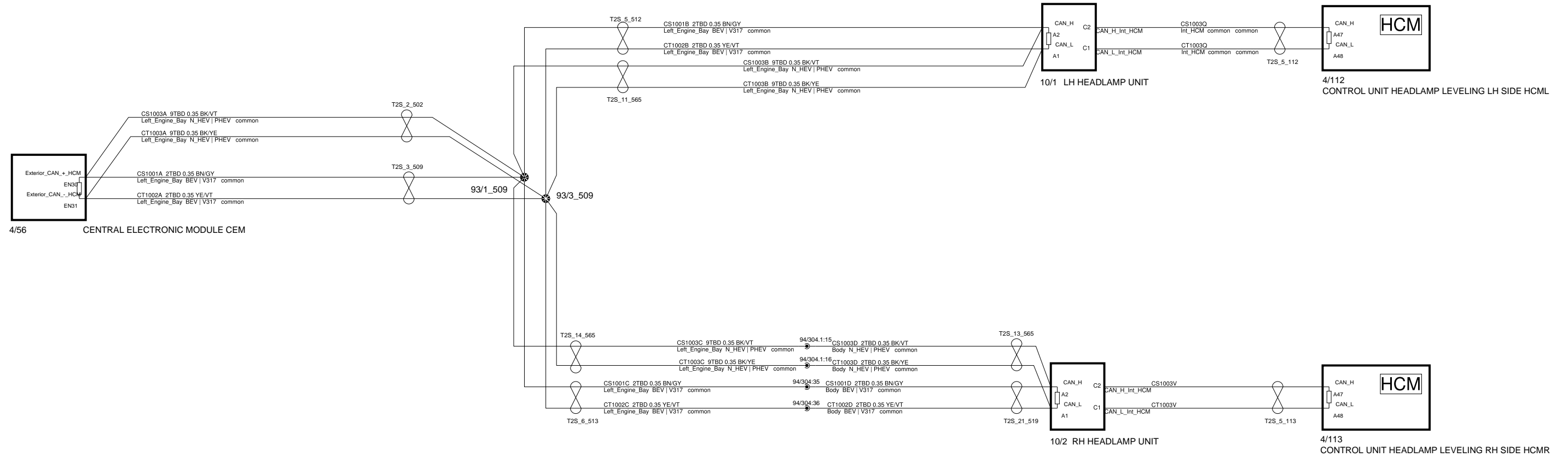

<p>The copying, distribution and utilization of this document as well as the communication of its contents to others without expressed authorization is prohibited. Offenders will be held liable for payment of damages. All rights reserved in the event of the grant of a patent, utility model or ornamental design registration.</p> <p><b>VOLVO</b> VOLVO CAR CORPORATION</p>	<b>Document title</b> CMA_622A_CC_All_5_30 1E_CAN_Body_Exp	
	<b>Document Type</b> DRAW/ELSY	<b>Release Status</b> RELEASED
	Volvo Document No 33445458	<b>Edited</b> May/22/2022
	<b>Issue</b> 030	<b>Page No</b> 18/149

# 1E Body-CAN

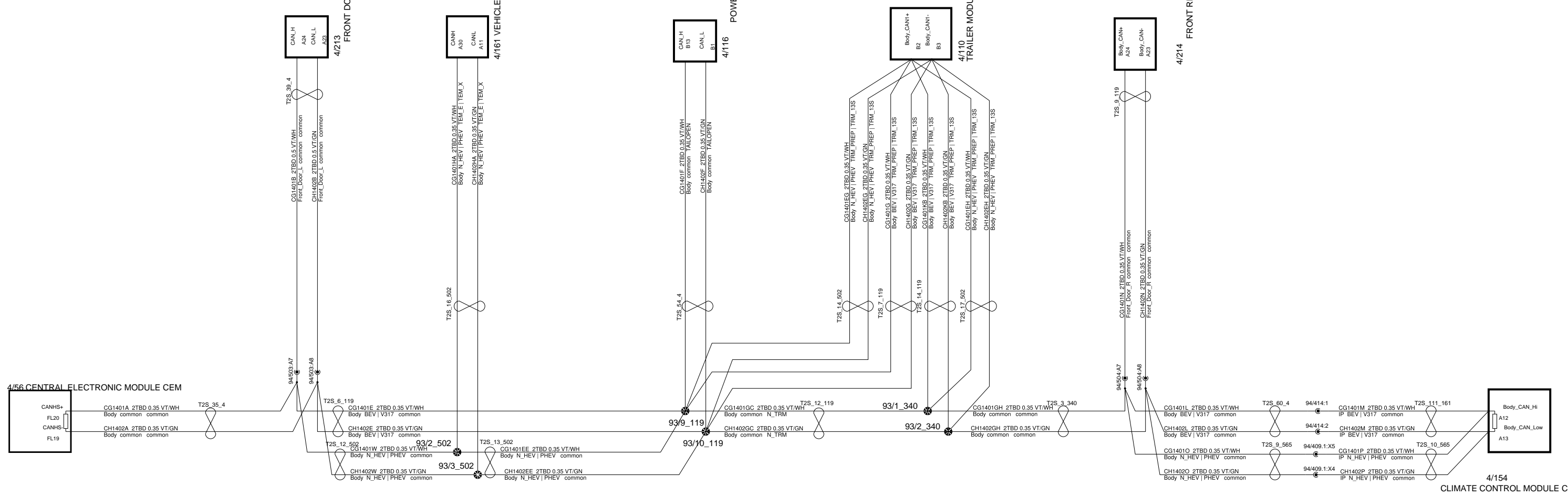

<p>The copying, distribution and utilization of this document as well as the communication of its contents to others without expressed authorization is prohibited. Offenders will be held liable for payment of damages. All rights reserved in the event of the grant of a patent, utility model or ornamental design registration.</p> <p><b>VOLVO</b> VOLVO CAR CORPORATION</p>	<b>Document title</b> CMA_622A_CC_All_5_30 1E_CAN_Body	
	<b>Document Type</b> DRAW/ELSY	<b>Release Status</b> RELEASED
	Volvo Document No 33445458	<b>Edited</b> March/01/2022
	<b>Issue</b> 030	<b>Page No</b> 17/149

# 1E Chassie CAN

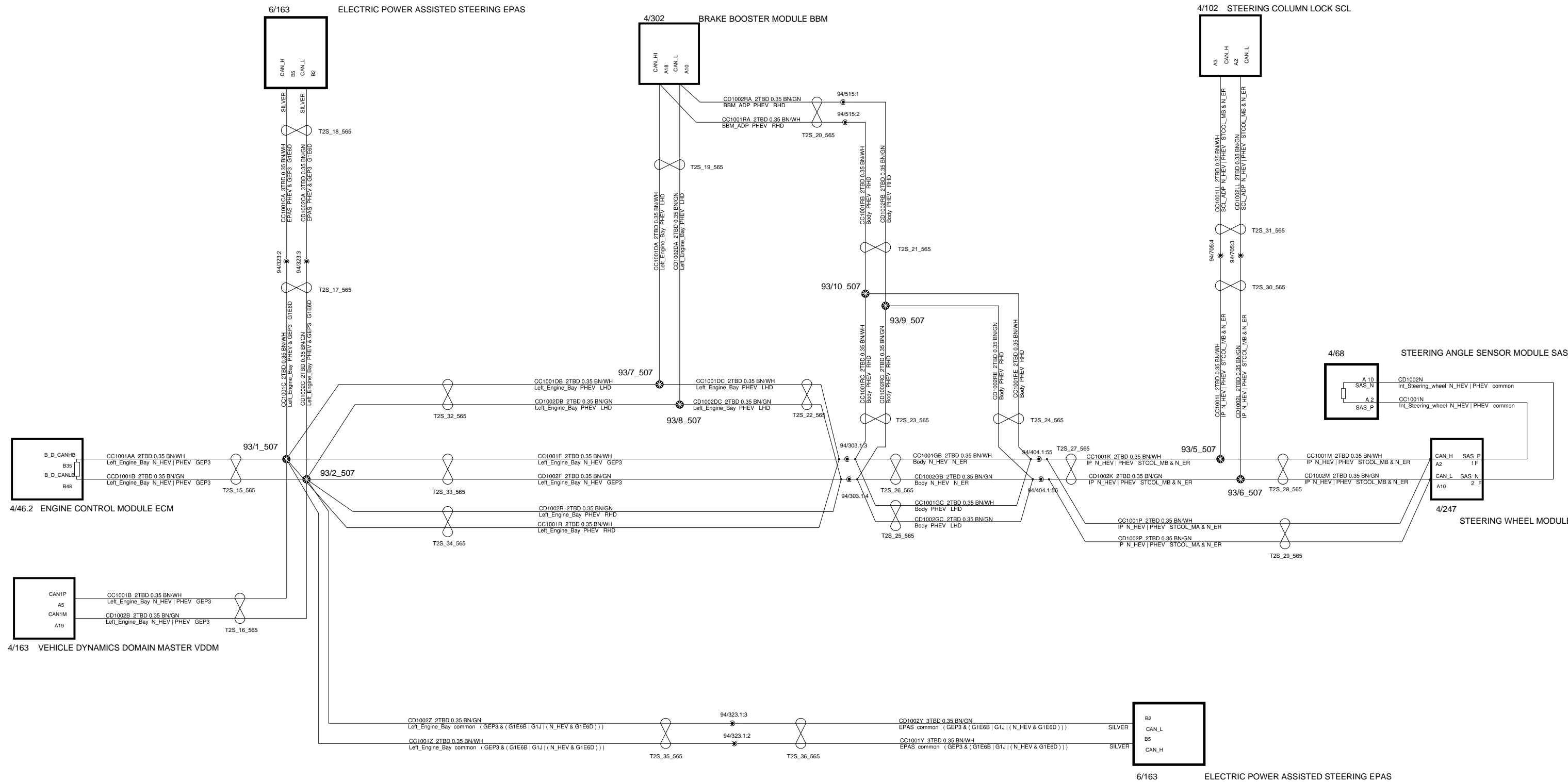

<p>The copying, distribution and utilization of this document as well as the communication of its contents to others without expressed authorization is prohibited. Offenders will be held liable for payment of damages. All rights reserved in the event of the grant of a patent, utility model or ornamental design registration.</p> <p><b>VOLVO</b> VOLVO CAR CORPORATION</p>	<b>Document title</b> CMA_622A_CC_A11_5_30	
	1E_CAN_Chassie	
	<b>Document Type</b> DRAW/ELSY	<b>Release Status</b> RELEASED
	CEVT Document No 8888522365	<b>Edited</b> May/22/2022
<b>Issue</b> 030	<b>Page No</b> 19/149	

# 1E Diagnostics and Connectivity CAN

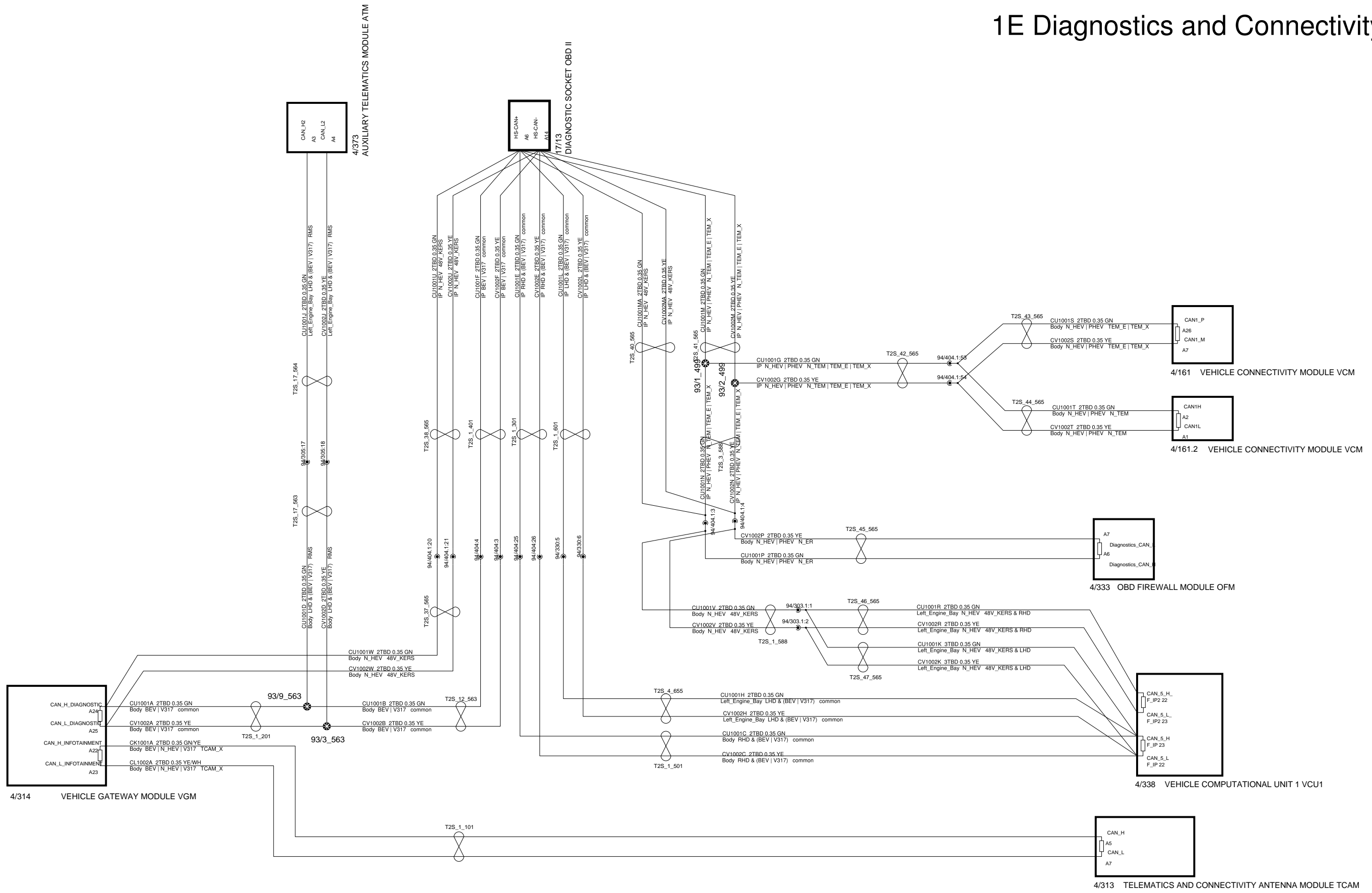

<p>The copying, distribution and utilization of this document as well as the communication of its contents to others without expressed authorization is prohibited. Offenders will be held liable for payment of damages. All rights reserved in the event of the grant of a patent, utility model or ornamental design registration.</p> <p><b>VOLVO</b> VOLVO CAR CORPORATION</p>	<b>Document title</b> CMA_622A_CC_All_5_30 1E_CAN_Connectivity_Diagnostics	
	<b>Document Type</b> DRAW/ELSY	<b>Release Status</b> RELEASED
	Volvo Document No 33445458	<b>Edited</b> June/16/2021
	<b>Issue</b> 030	<b>Page No</b> 20/149

# 1E Engine CAN

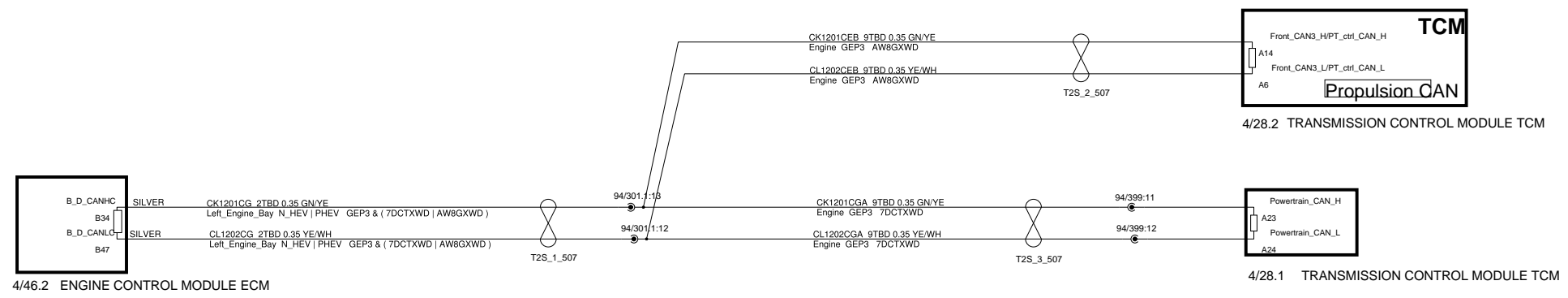

<p>The copying, distribution and utilization of this document as well as the communication of its contents to others without expressed authorization is prohibited. Offenders will be held liable for payment of damages. All rights reserved in the event of the grant of a patent, utility model or ornamental design registration.</p> <p><b>VOLVO</b> VOLVO CAR CORPORATION</p>	<b>Document title</b> CMA_622A_CC_All_5_30 1E_CAN_Engine	
	<b>Document Type</b> DRAW/ELSY	<b>Release Status</b> RELEASED
	CEVT Document No 8888522365	<b>Edited</b> February/01/2021
	<b>Issue</b> 030	<b>Page No</b> 21/149

# 1E Front 1 CAN

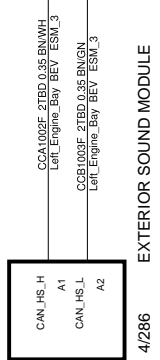
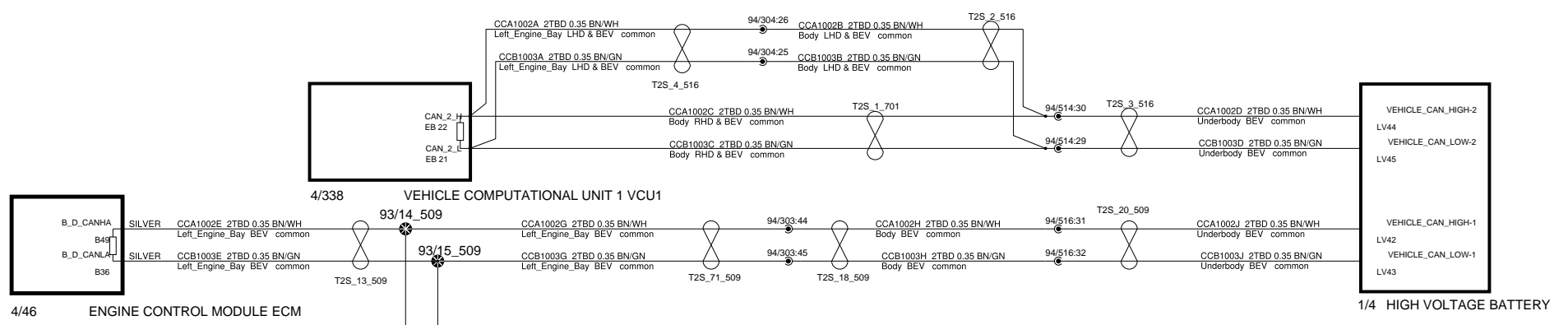
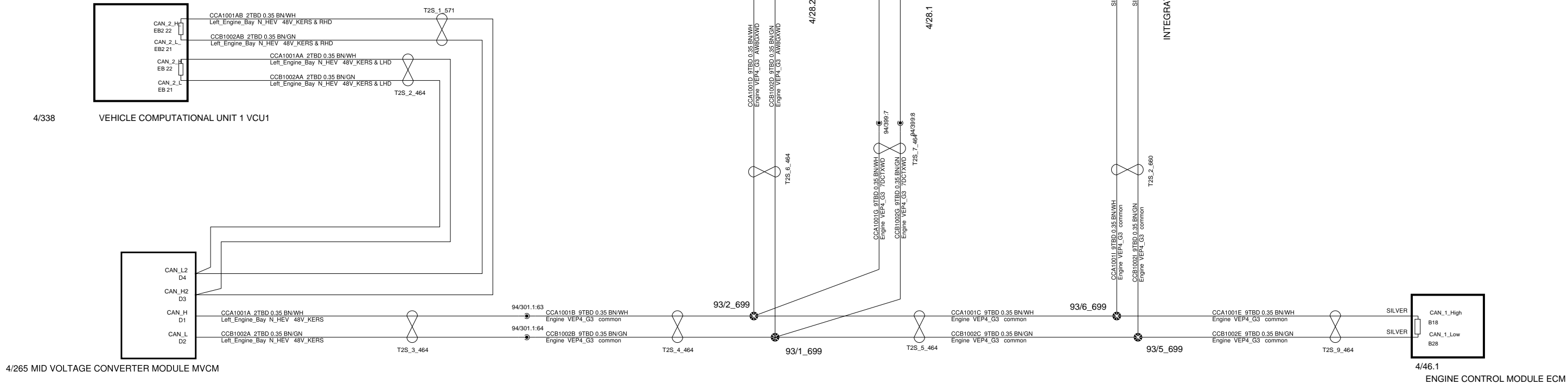

<p>The copying, distribution and utilization of this document as well as the communication of its contents to others without expressed authorization is prohibited. Offenders will be held liable for payment of damages. All rights reserved in the event of the grant of a patent, utility model or ornamental design registration.</p> <p><b>VOLVO</b> VOLVO CAR CORPORATION</p>		<p><b>Document title</b> CMA_622A_CC_All_5_30</p> <p>1E_CAN_Front_1</p>	
		<p><b>Document Type</b> DRAW/ELSY</p>	<p><b>Release Status</b> RELEASED</p>
		<p>Volvo Document No 33445458</p>	<p><b>Edited</b> February/16/2022</p>
		<p><b>Issue</b> 030</p>	<p><b>Page No</b> 22/149</p>

# 1E Front 3 CAN

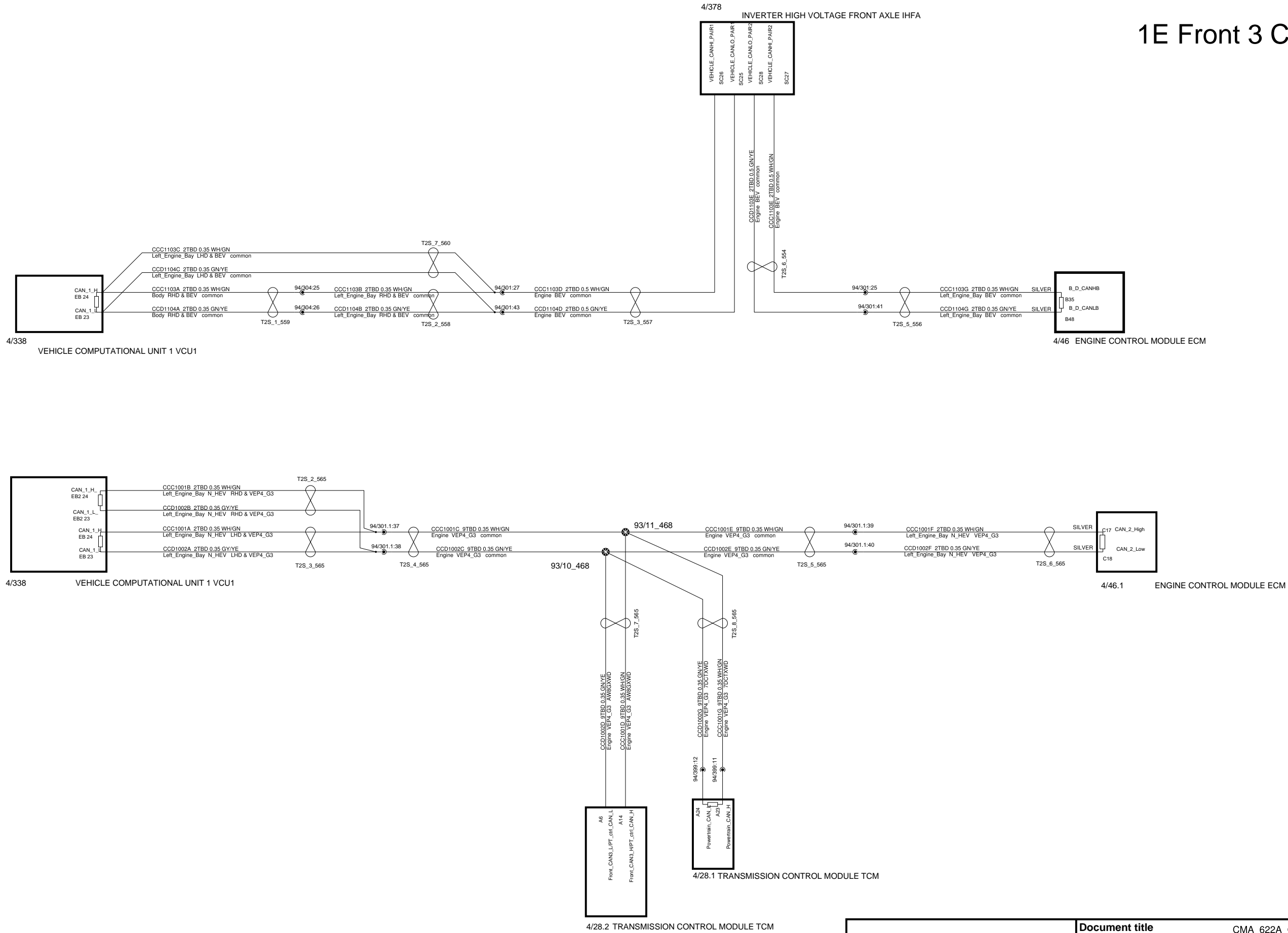

<p>The copying, distribution and utilization of this document as well as the communication of its contents to others without expressed authorization is prohibited. Offenders will be held liable for payment of damages. All rights reserved in the event of the grant of a patent, utility model or ornamental design registration.</p> <p><b>VOLVO</b> VOLVO CAR CORPORATION</p>	<b>Document title</b> CMA_622A_CC_All_5_30	
	1E_CAN_Front_3	
	<b>Document Type</b> DRAW/ELSY	<b>Release Status</b> RELEASED
	Volvo Document No 33445458	<b>Edited</b> February/16/2022
<b>Issue</b> 030	<b>Page No</b> 23/149	



# 1E Front CAN Exposed

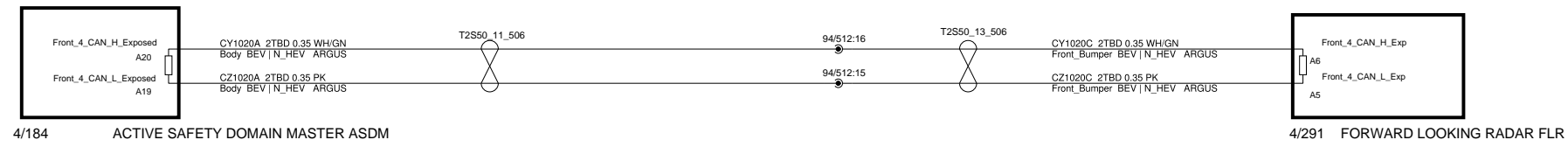

<p>The copying, distribution and utilization of this document as well as the communication of its contents to others without expressed authorization is prohibited. Offenders will be held liable for payment of damages. All rights reserved in the event of the grant of a patent, utility model or ornamental design registration.</p> <p><b>VOLVO</b> VOLVO CAR CORPORATION</p>	<b>Document title</b> CMA_622A_CC_All_5_30 1E_CAN_Front_Exposed	
	<b>Document Type</b> DRAW/ELSY	<b>Release Status</b> RELEASED
	Volvo Document No 33445458	<b>Edited</b> September/30/2020
	<b>Issue</b> 030	<b>Page No</b> 24/149

ELECTRIC POWER ASSISTED STEERING EPAS

# 1E Mid 1 CAN

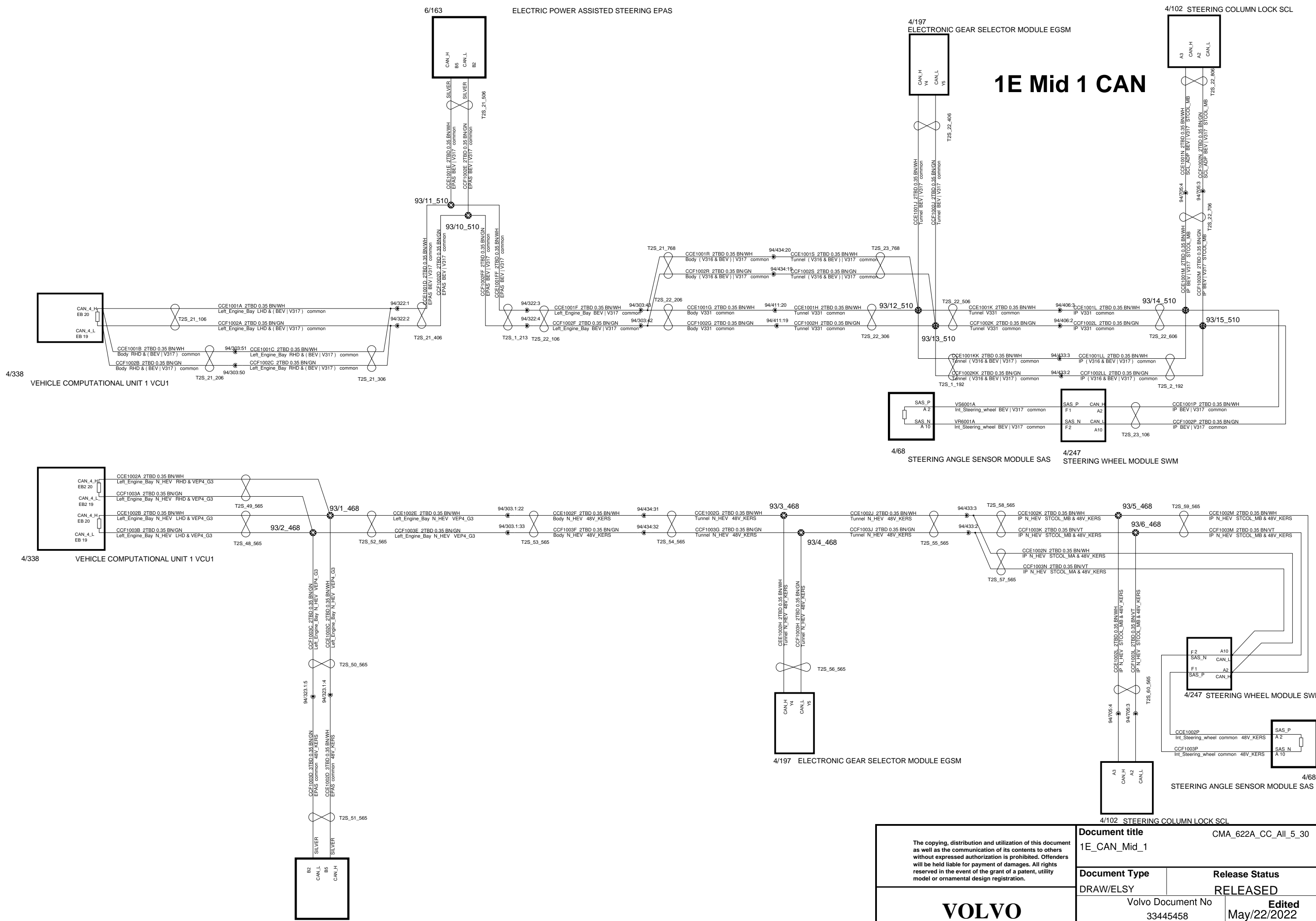

The copying, distribution and utilization of this document as well as the communication of its contents to others without expressed authorization is prohibited. Offenders will be held liable for payment of damages. All rights reserved in the event of the grant of a patent, utility model or ornamental design registration.		<b>Document title</b> CMA_622A_CC_All_5_30	
		<b>Document title</b> 1E_CAN_Mid_1	
<b>Document Type</b> DRAW/ELSY		<b>Release Status</b> RELEASED	
Volvo Document No 33445458		<b>Edited</b> May/22/2022	
<b>Issue</b> 030		<b>Page No</b> 25/149	



6/163 ELECTRIC POWER ASSISTED STEERING EPAS

4/197 ELECTRONIC GEAR SELECTOR MODULE EGSM

4/68 STEERING ANGLE SENSOR MODULE SAS

4/102 STEERING COLUMN LOCK SCL

4/247 STEERING WHEEL MODULE SWM

4/338 VEHICLE COMPUTATIONAL UNIT 1 VCU1

4/338 VEHICLE COMPUTATIONAL UNIT 1 VCU1

# 1E Propulsion CAN Front

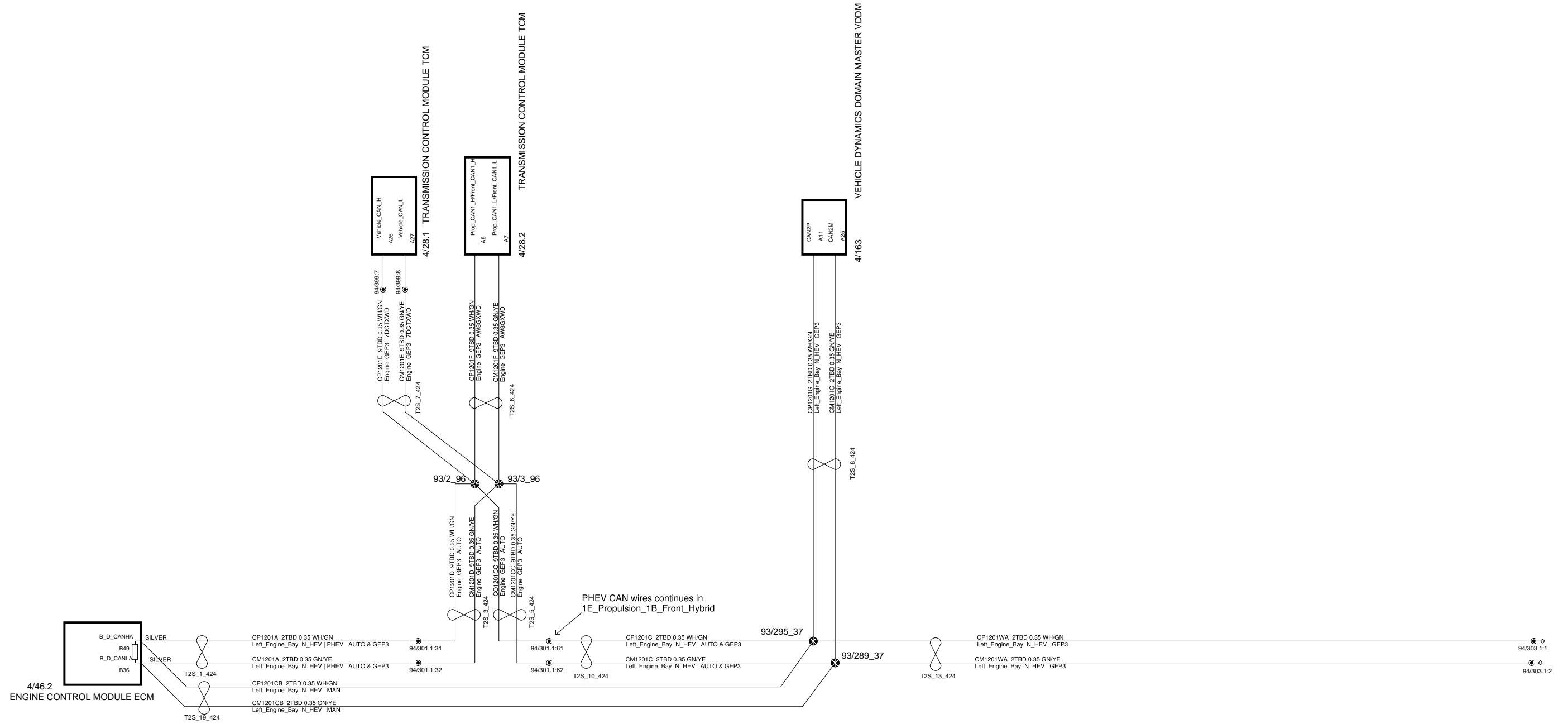

<p>The copying, distribution and utilization of this document as well as the communication of its contents to others without expressed authorization is prohibited. Offenders will be held liable for payment of damages. All rights reserved in the event of the grant of a patent, utility model or ornamental design registration.</p> <p><b>VOLVO</b> VOLVO CAR CORPORATION</p>	<b>Document title</b> CMA_622A_CC_All_5_30 1E_CAN_Propulsion_1A_Front	
	<b>Document Type</b> DRAW/ELSY	<b>Release Status</b> RELEASED
	CEVT Document No 8888522365	<b>Edited</b> March/15/2022
	<b>Issue</b> 030	<b>Page No</b> 26/149

# 1E Propulsion CAN Front Hybrid

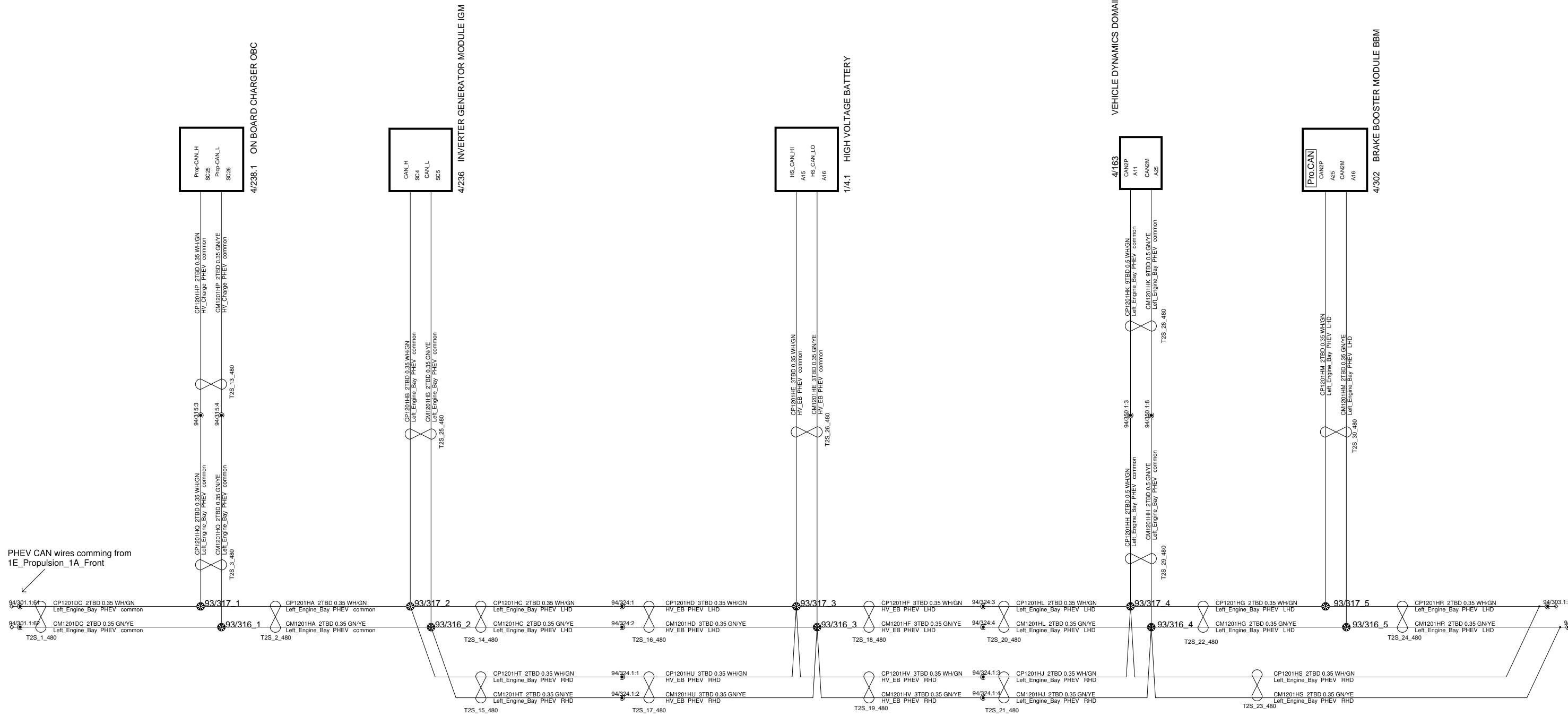

<p>The copying, distribution and utilization of this document as well as the communication of its contents to others without expressed authorization is prohibited. Offenders will be held liable for payment of damages. All rights reserved in the event of the grant of a patent, utility model or ornamental design registration.</p> <p><b>VOLVO</b> VOLVO CAR CORPORATION</p>	<b>Document title</b> CMA_622A_CC_All_5_30 1E_CAN_Propulsion_1B_Front_Hybrid	
	<b>Document Type</b> DRAW/ELSY	<b>Release Status</b> RELEASED
	CEVT Document No 8888522365	<b>Edited</b> March/17/2022
	<b>Issue</b> 030	<b>Page No</b> 27/149

# 1E Propulsion CAN Centre

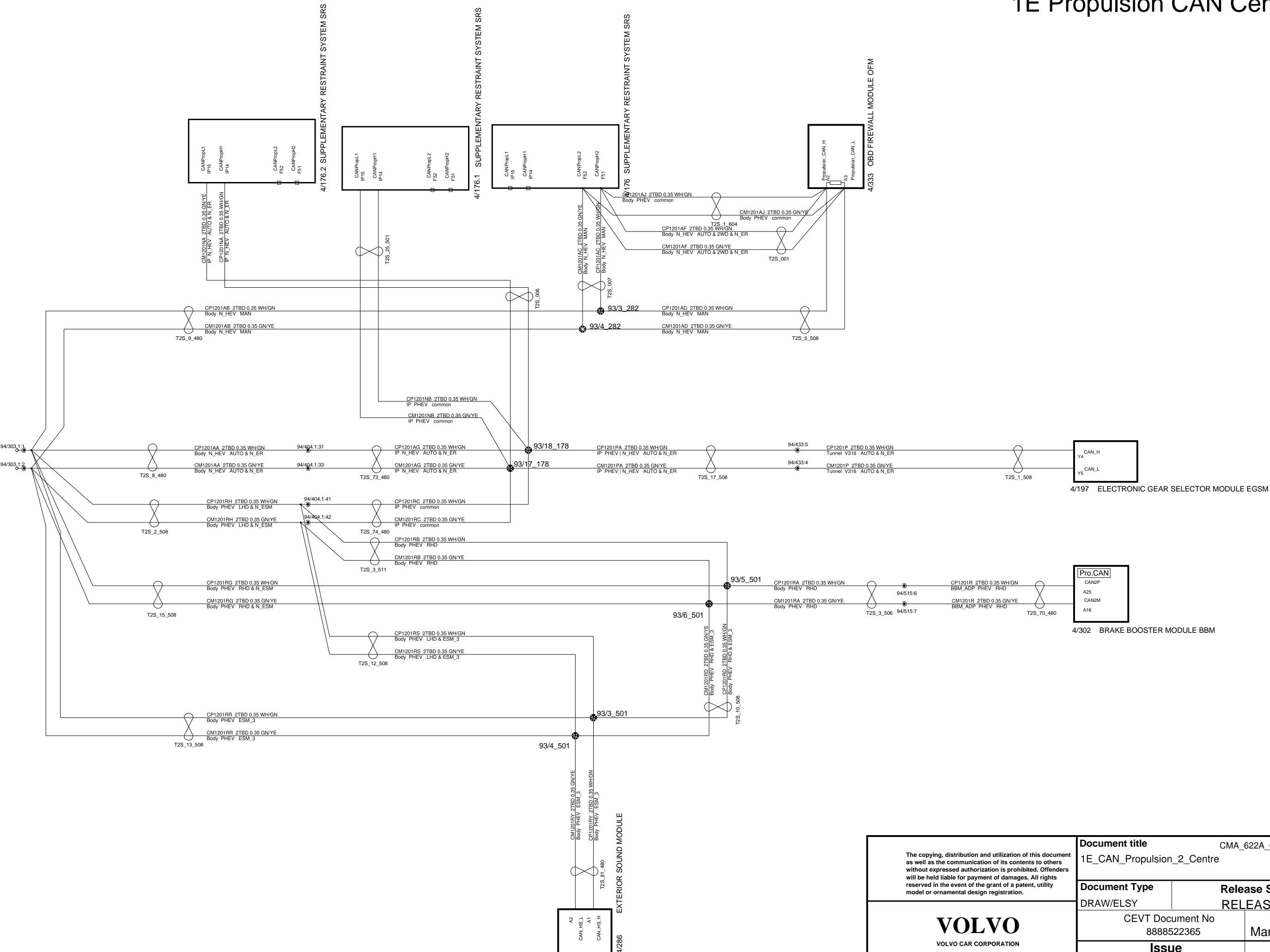

<p>The copying, distribution and utilization of this document as well as the communication of its contents to others without expressed authorization is prohibited. Offenders will be held liable for payment of damages. All rights reserved in the event of the grant of a patent, utility model or ornamental design registration.</p>		<b>Document title</b> CMA_622A_CC_All_5_30 1E_CAN_Propulsion_2_Centre	
		<b>Document Type</b> DRAW/ELSY	<b>Release Status</b> RELEASED
 VOLVO CAR CORPORATION		CEVT Document No 8888522365	<b>Edited</b> March/17/2022
		<b>Issue</b> 030	<b>Page No</b> 28/149

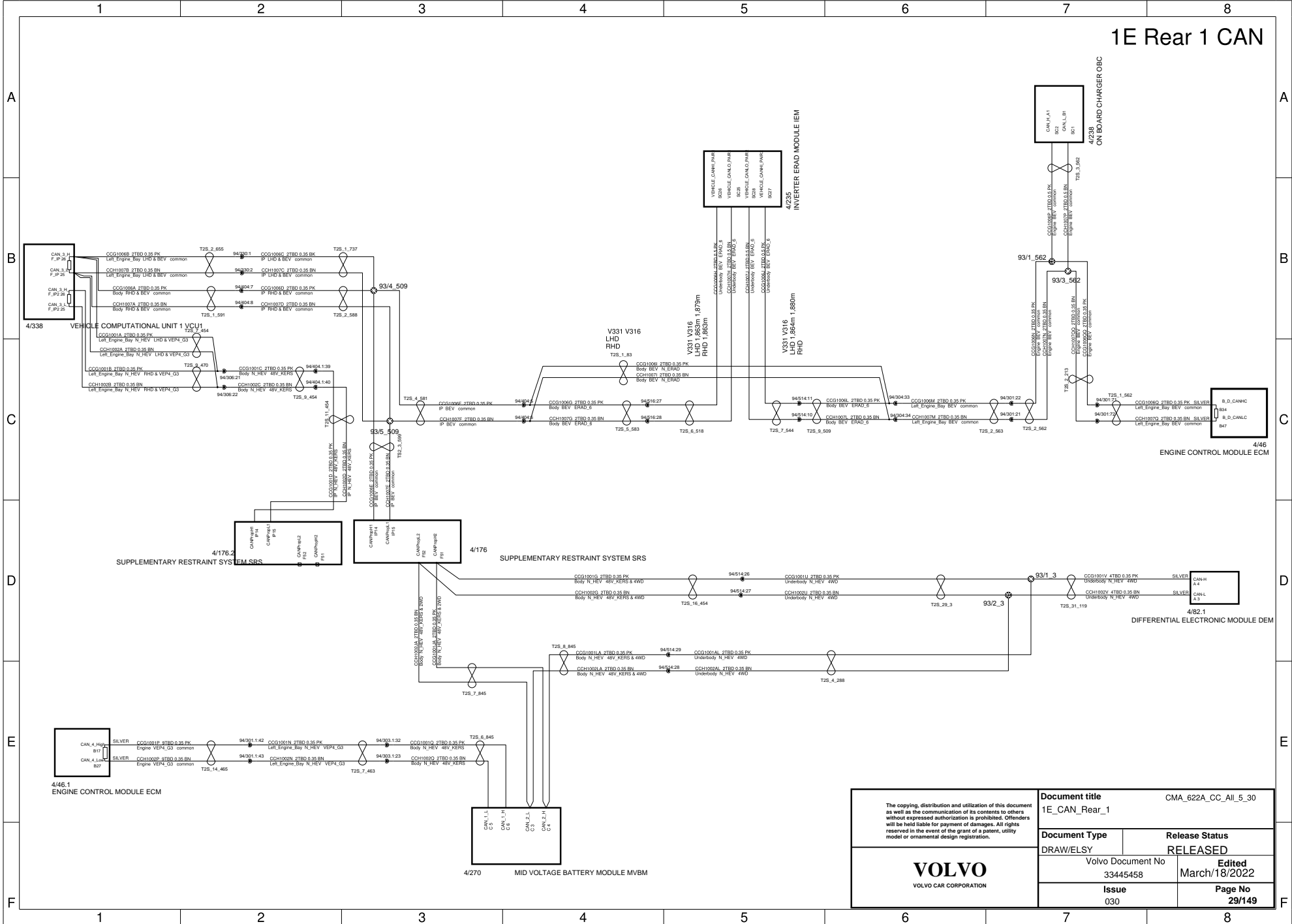

1E Rear 1 CAN

<p>The copying, distribution and utilization of this document as well as the communication of its contents to others without expressed authorization is prohibited. Offenders will be held liable for payment of damages. All rights reserved in the event of the grant of a patent, utility model or ornamental design registration.</p> <p><b>VOLVO</b> VOLVO CAR CORPORATION</p>		<p>Document title 1E_CAN_Rear_1</p>	<p>CMA_622A_CC_All_5_30</p>
		<p>Document Type DRAW/ELSY</p>	<p>Release Status RELEASED</p>
		<p>Volvo Document No 33445458</p>	<p>Edited March/18/2022</p>
		<p>Issue 030</p>	<p>Page No 29/149</p>

# 1E Safety CAN Exposed BEV 48V KERS

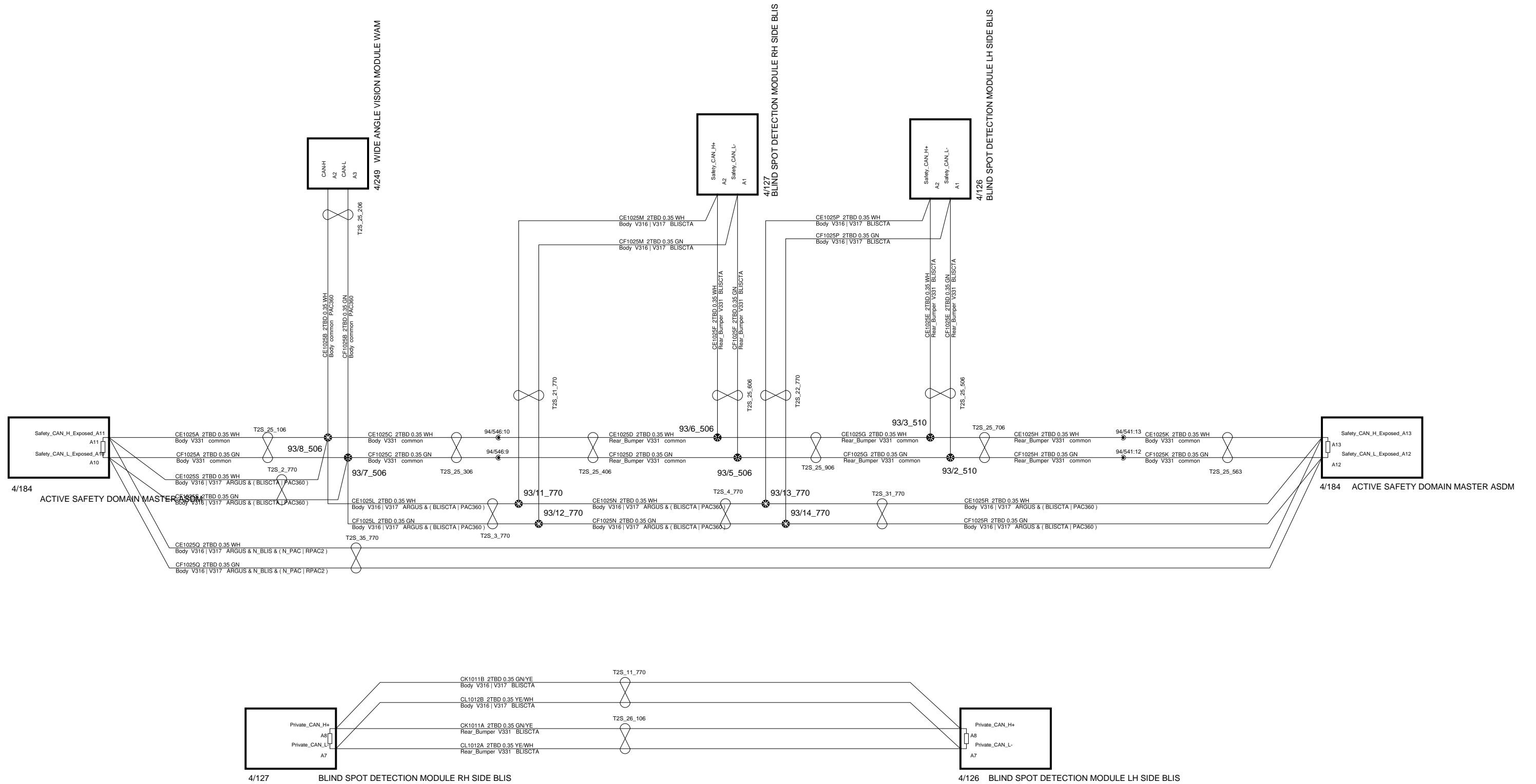

<p>The copying, distribution and utilization of this document as well as the communication of its contents to others without expressed authorization is prohibited. Offenders will be held liable for payment of damages. All rights reserved in the event of the grant of a patent, utility model or ornamental design registration.</p> <p><b>VOLVO</b> VOLVO CAR CORPORATION</p>	<b>Document title</b> CMA_622A_CC_All_5_30 1E_CAN_Safety_Exposed_BEV_48V_KERS	
	<b>Document Type</b> DRAW/ELSY	<b>Release Status</b> RELEASED
	Volvo Document No 33445458	<b>Edited</b> February/16/2022
	<b>Issue</b> 030	<b>Page No</b> 30/149

# 1E Safety CAN Exposed ICE PHEV

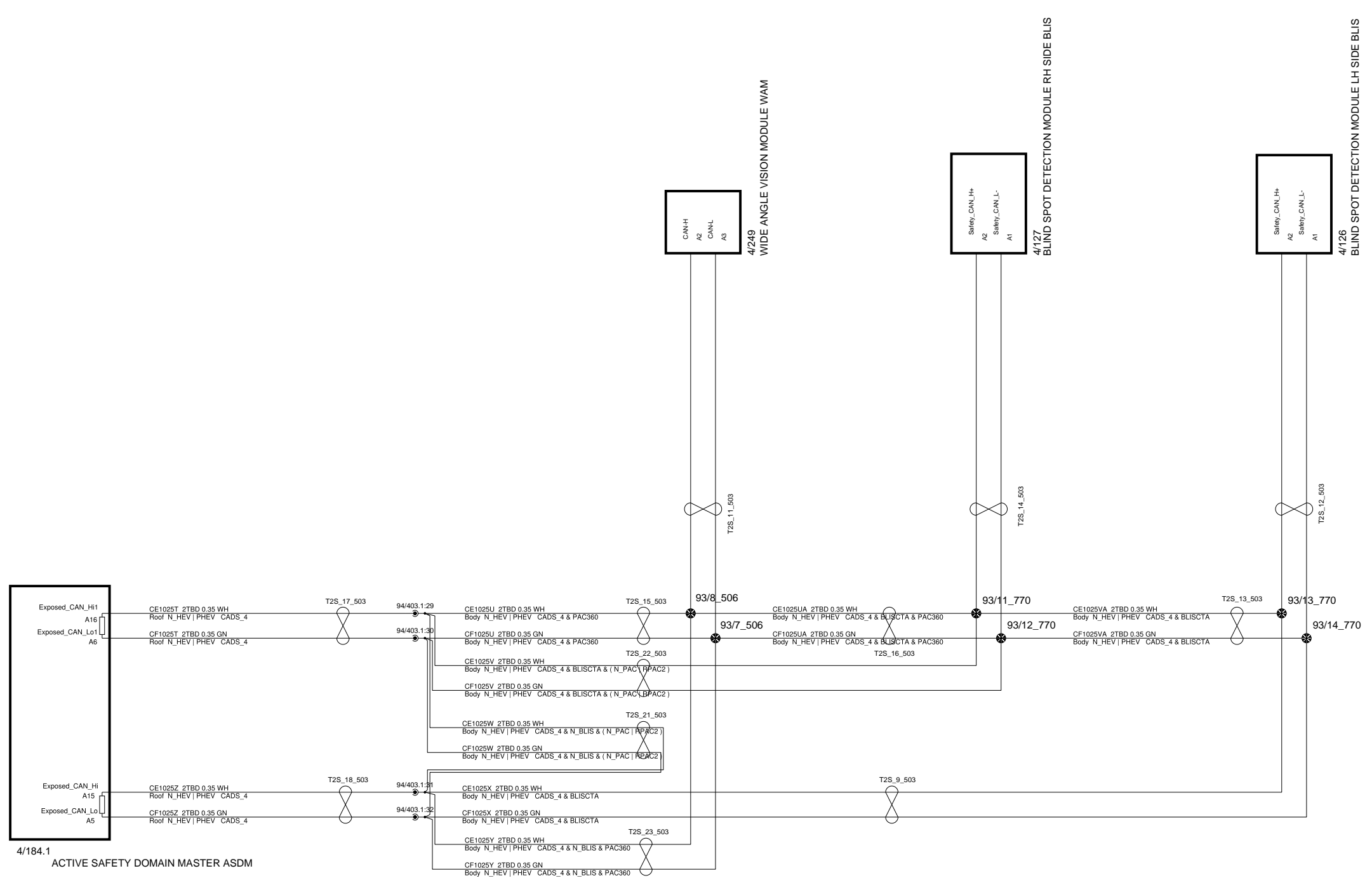

<p>The copying, distribution and utilization of this document as well as the communication of its contents to others without expressed authorization is prohibited. Offenders will be held liable for payment of damages. All rights reserved in the event of the grant of a patent, utility model or ornamental design registration.</p> <p><b>VOLVO</b> VOLVO CAR CORPORATION</p>	<p><b>Document title</b> CMA_622A_CC_All_5_30 1E_CAN_Safety_Exposed_ICE_PHEV</p>	
	<p><b>Document Type</b> DRAW/ELSY</p>	<p><b>Release Status</b> RELEASED</p>
	<p>CEVT Document No 8888522365</p>	<p><b>Edited</b> February/16/2022</p>
	<p><b>Issue</b> 030</p>	<p><b>Page No</b> 31/149</p>



# 1E Safety CAN Protected

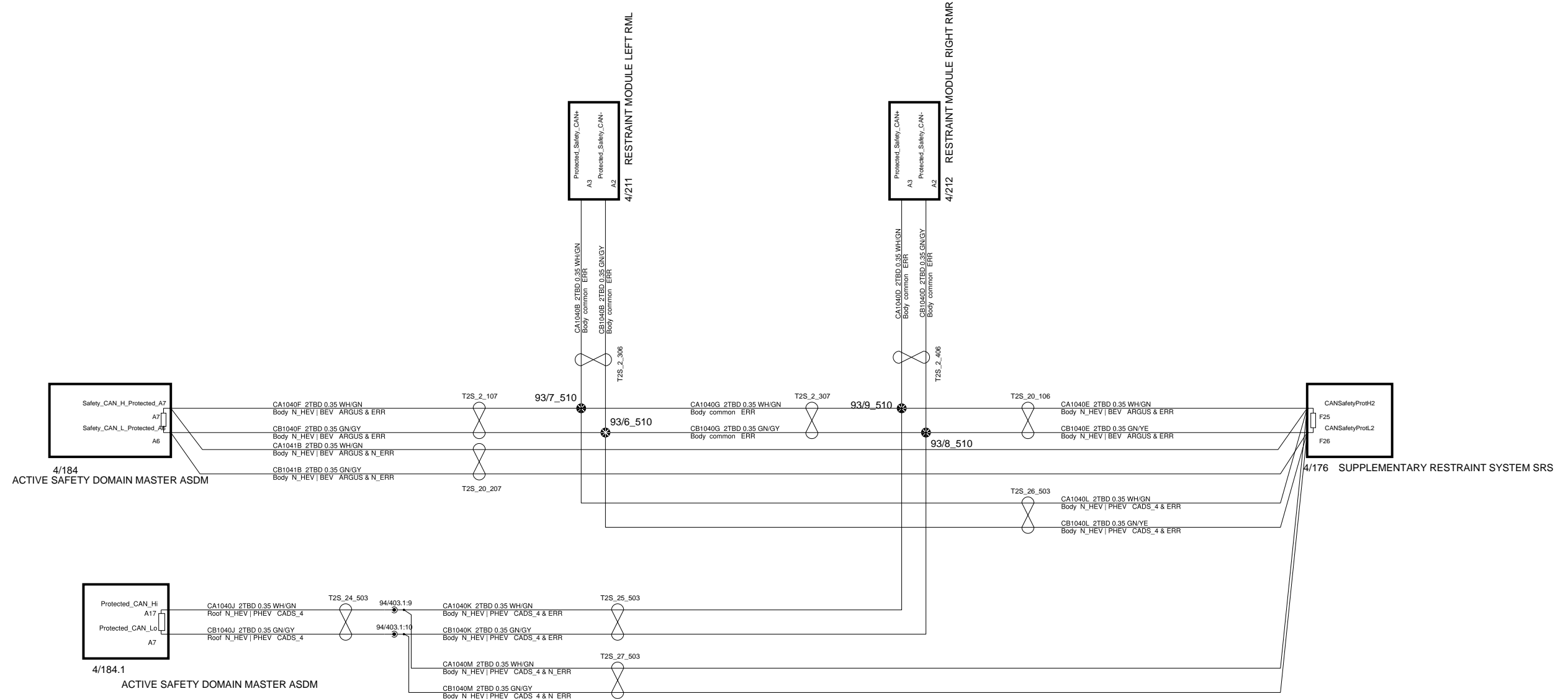

<p>The copying, distribution and utilization of this document as well as the communication of its contents to others without expressed authorization is prohibited. Offenders will be held liable for payment of damages. All rights reserved in the event of the grant of a patent, utility model or ornamental design registration.</p> <p><b>VOLVO</b> VOLVO CAR CORPORATION</p>	<b>Document title</b> CMA_622A_CC_A11_5_30 1E_CAN_Safety_Protected	
	<b>Document Type</b> DRAW/ELSY	<b>Release Status</b> RELEASED
	Volvo Document No 33445458	<b>Edited</b> May/22/2022
	<b>Issue</b> 030	<b>Page No</b> 32/149

# 1E\_Backbone\_FlexRay BEV|48V KERS

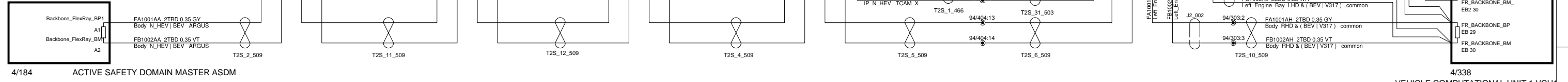

<p>The copying, distribution and utilization of this document as well as the communication of its contents to others without expressed authorization is prohibited. Offenders will be held liable for payment of damages. All rights reserved in the event of the grant of a patent, utility model or ornamental design registration.</p> <p><b>VOLVO</b> VOLVO CAR CORPORATION</p>	<b>Document title</b> CMA_622A_CC_All_5_30 1E_FlexRay_Backbone_BEV_48V_KERS	
	<b>Document Type</b> DRAW/ELSY	<b>Release Status</b> RELEASED
	Volvo Document No 33445458	<b>Edited</b> March/15/2022
	<b>Issue</b> 030	<b>Page No</b> 33/149

# 1E\_Backbone\_FlexRay\_ICE|PHEV

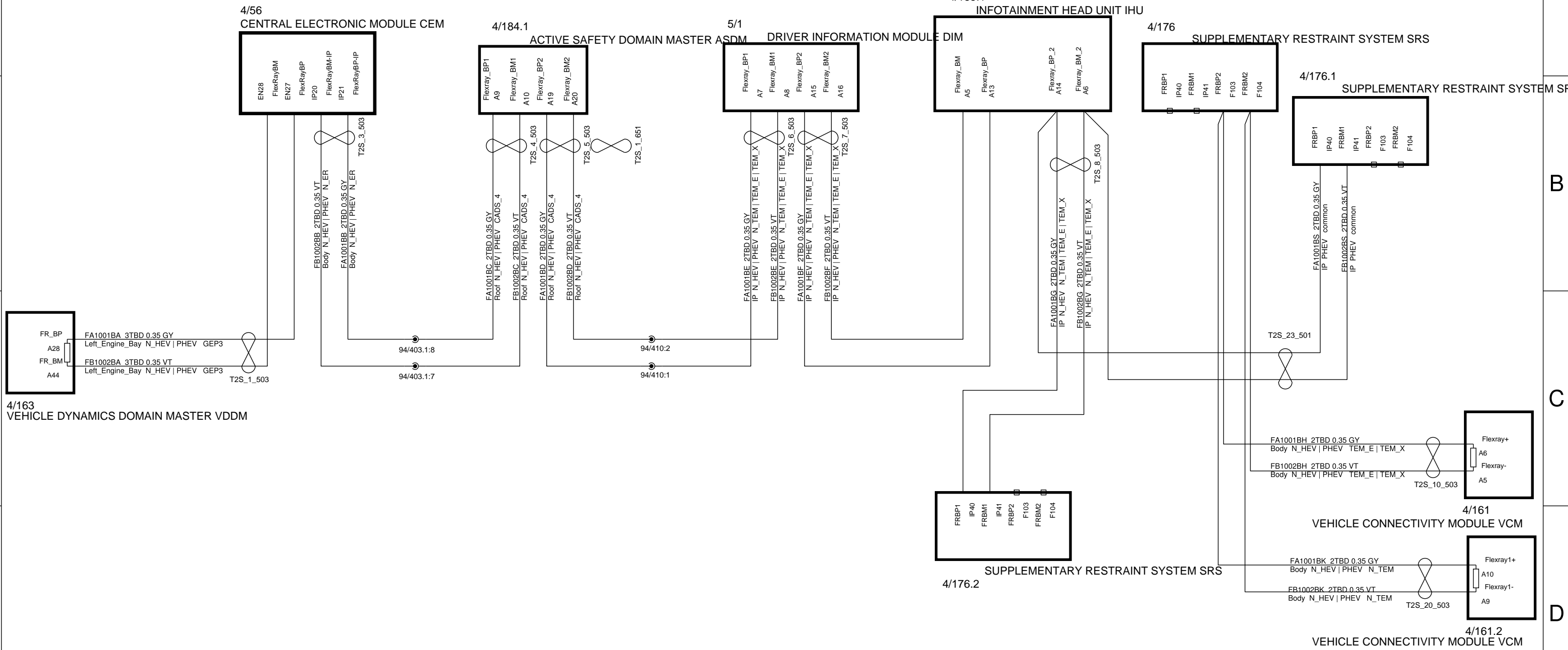

<p>The copying, distribution and utilization of this document as well as the communication of its contents to others without expressed authorization is prohibited. Offenders will be held liable for payment of damages. All rights reserved in the event of the grant of a patent, utility model or ornamental design registration.</p> <p><b>VOLVO</b> VOLVO CAR CORPORATION</p>	<p><b>Document title</b> CMA_622A_CC_All_5_30 1E_FlexRay_Backbone_ICE_PHEV</p>	
	<p><b>Document Type</b> DRAW/ELSY</p>	<p><b>Release Status</b> RELEASED</p>
	<p>CEVT Document No 8888522365</p>	<p><b>Edited</b> March/17/2022</p>
	<p><b>Issue</b> 030</p>	<p><b>Page No</b> 34/149</p>

# 1E Front 2 FlexRay

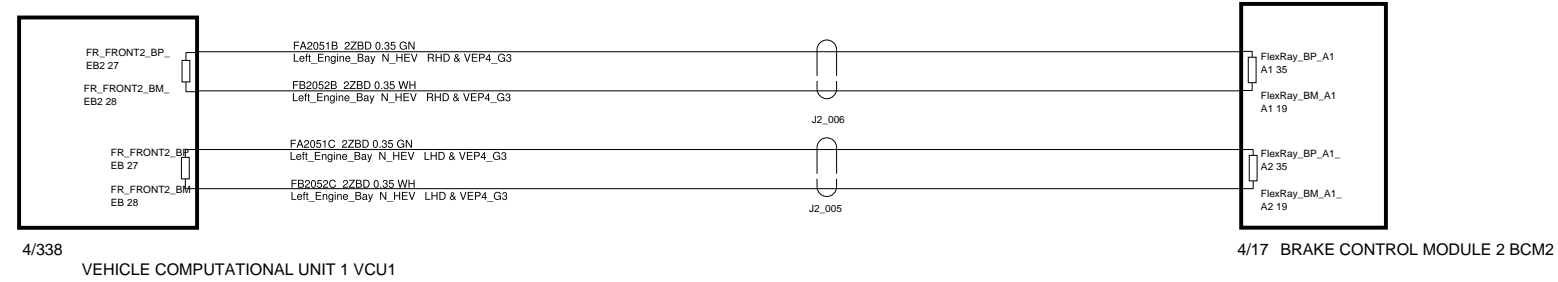
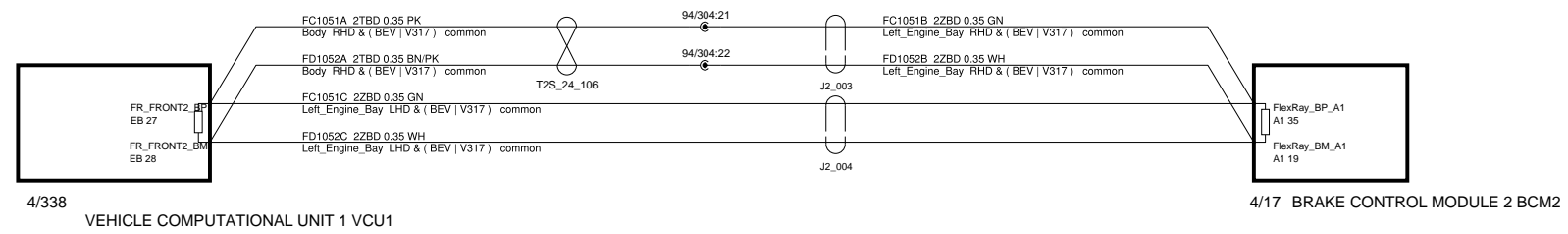

<p>The copying, distribution and utilization of this document as well as the communication of its contents to others without expressed authorization is prohibited. Offenders will be held liable for payment of damages. All rights reserved in the event of the grant of a patent, utility model or ornamental design registration.</p> <p><b>VOLVO</b> VOLVO CAR CORPORATION</p>	<b>Document title</b> CMA_622A_CC_A11_5_30 1E_FlexRay_Front_2	
	<b>Document Type</b> DRAW/ELSY	<b>Release Status</b> RELEASED
	Volvo Document No 33445458	<b>Edited</b> February/16/2022
	<b>Issue</b> 030	<b>Page No</b> 35/149

# 1E Mid 2 FlexRay

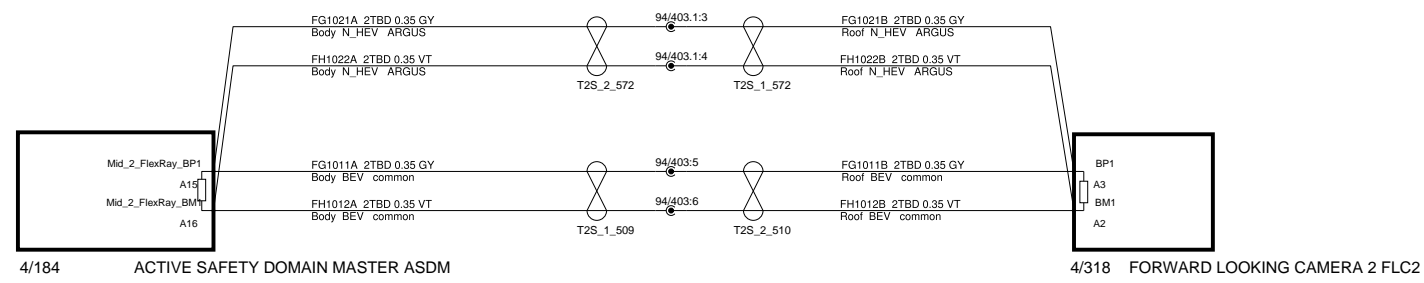

<p>The copying, distribution and utilization of this document as well as the communication of its contents to others without expressed authorization is prohibited. Offenders will be held liable for payment of damages. All rights reserved in the event of the grant of a patent, utility model or ornamental design registration.</p> <p><b>VOLVO</b> VOLVO CAR CORPORATION</p>	<b>Document title</b> CMA_622A_CC_All_5_30 1E_FlexRay_Mid_2	
	<b>Document Type</b> DRAW/ELSY	<b>Release Status</b> RELEASED
	Volvo Document No 33445458	<b>Edited</b> February/16/2022
	<b>Issue</b> 030	<b>Page No</b> 36/149

# 1E LIN Body Infotainment Powertrain

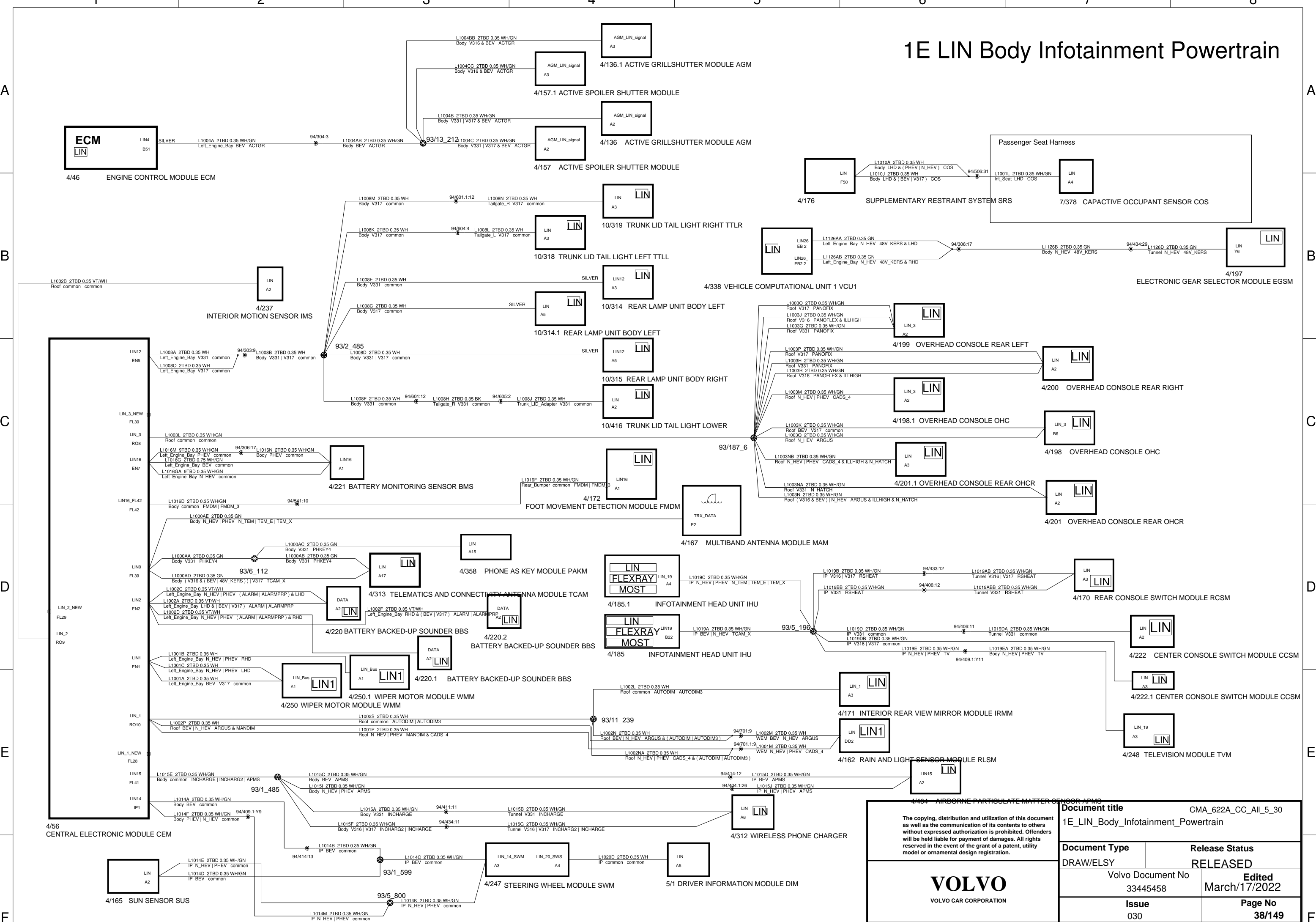

The copying, distribution and utilization of this document as well as the communication of its contents to others without expressed authorization is prohibited. Offenders will be held liable for payment of damages. All rights reserved in the event of the grant of a patent, utility model or ornamental design registration.

**VOLVO**  
VOLVO CAR CORPORATION

Document title		CMA_622A_CC_All_5_30	
1E_LIN_Body_Infotainment_Powertrain			
Document Type	Release Status		
DRAW/ELSY	RELEASED		
Volvo Document No		Edited	
33445458		March/17/2022	
Issue	Page No		
030	38/149		

# 1E LIN Body

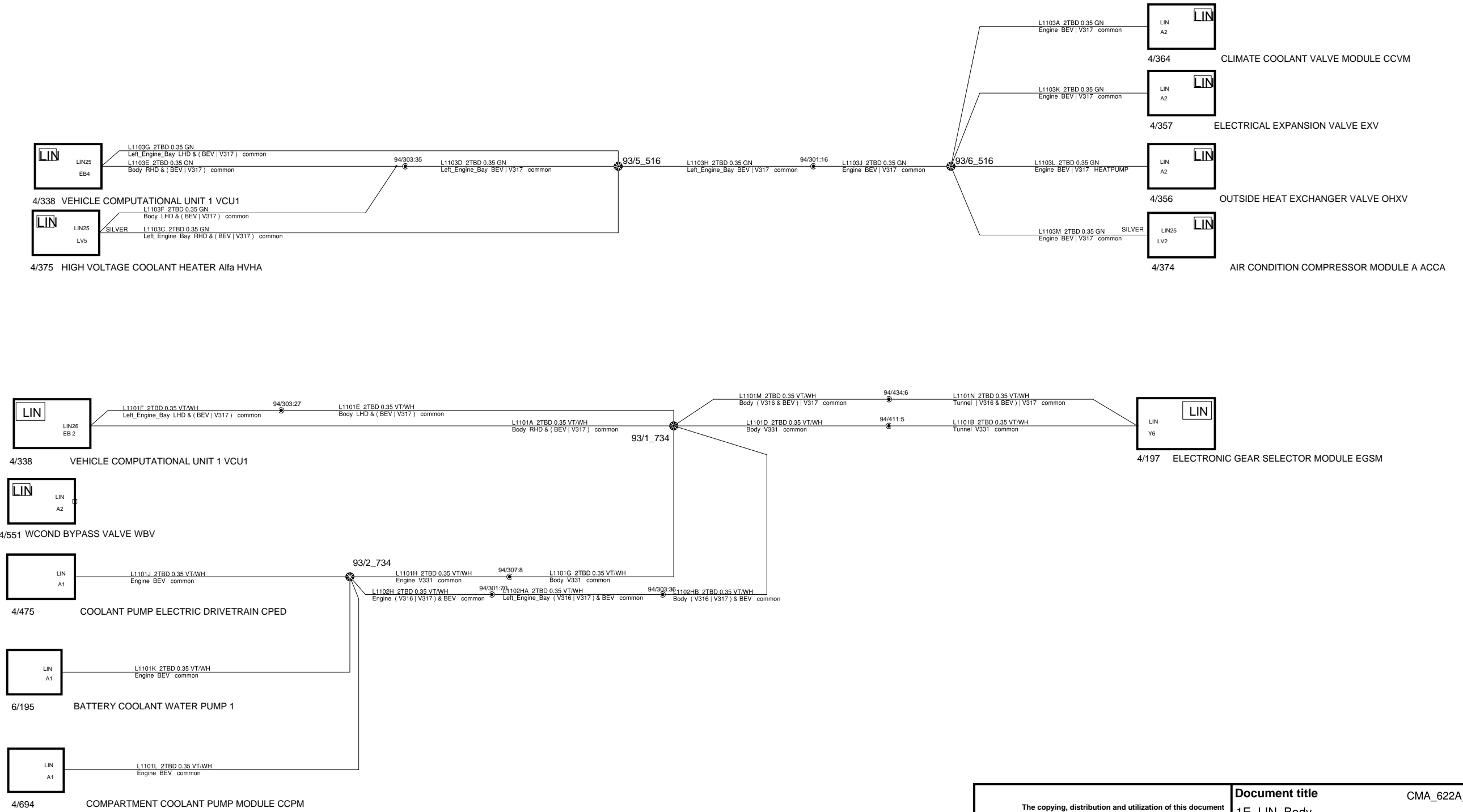

<p>The copying, distribution and utilization of this document as well as the communication of its contents to others without expressed authorization is prohibited. Offenders will be held liable for payment of damages. All rights reserved in the event of the grant of a patent, utility model or ornamental design registration.</p> <p><b>VOLVO</b> VOLVO CAR CORPORATION</p>	<b>Document title</b> CMA_622A_CC_All_5_30 1E_LIN_Body	
	<b>Document Type</b> DRAW/ELSY	<b>Release Status</b> RELEASED
	Volvo Document No 33445458	<b>Edited</b> May/22/2022
	<b>Issue</b> 030	<b>Page No</b> 37/149

# 1E LIN Comfort

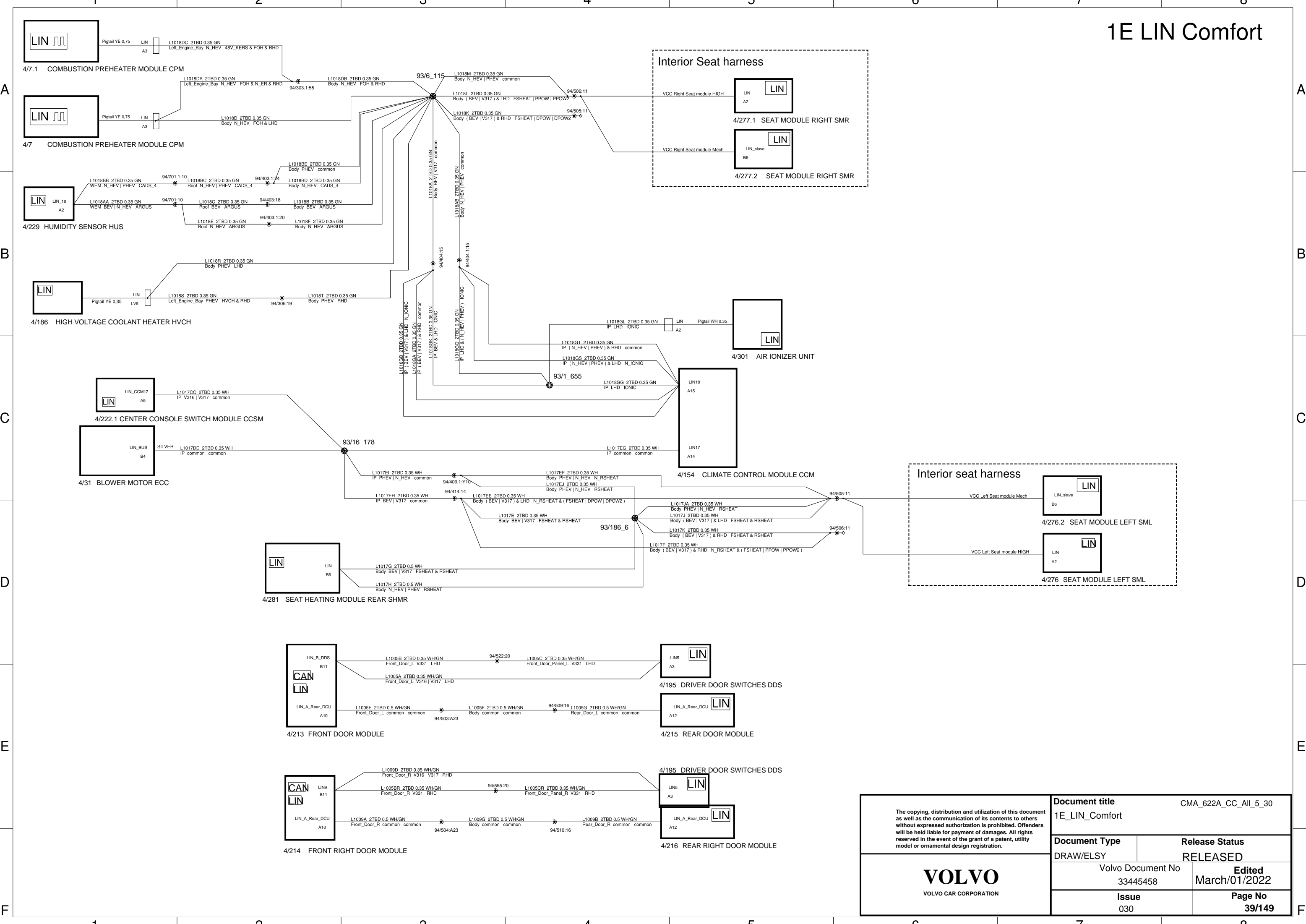

<b>VOLVO</b> VOLVO CAR CORPORATION	<b>Document title</b> CMA_622A_CC_All_5_30 1E_LIN_Comfort	
	<b>Document Type</b> DRAW/ELSY	<b>Release Status</b> RELEASED
	Volvo Document No 33445458	<b>Edited</b> March/01/2022
	<b>Issue</b> 030	<b>Page No</b> 39/149

The copying, distribution and utilization of this document as well as the communication of its contents to others without expressed authorization is prohibited. Offenders will be held liable for payment of damages. All rights reserved in the event of the grant of a patent, utility model or ornamental design registration.



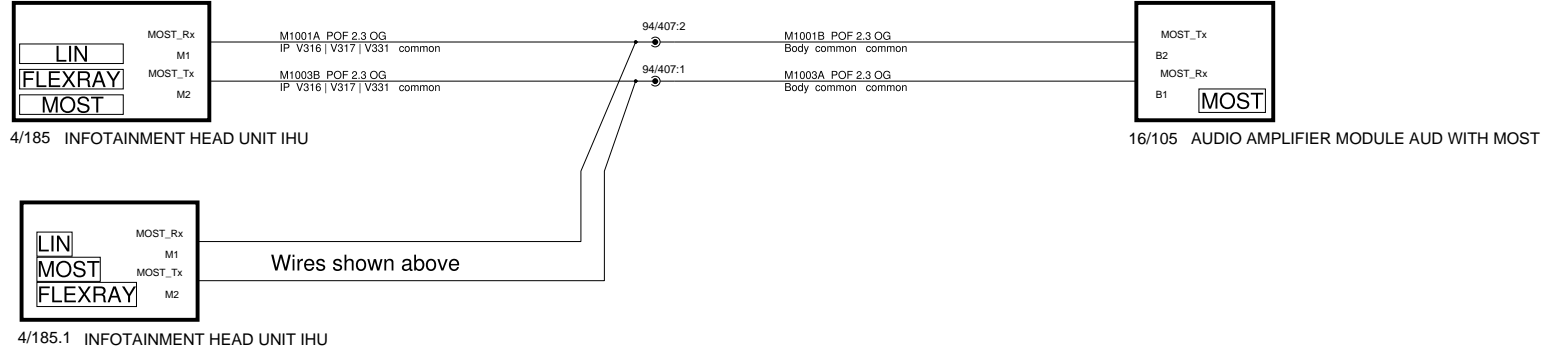

<p>The copying, distribution and utilization of this document as well as the communication of its contents to others without expressed authorization is prohibited. Offenders will be held liable for payment of damages. All rights reserved in the event of the grant of a patent, utility model or ornamental design registration.</p> <p><b>VOLVO</b> VOLVO CAR CORPORATION</p>	<b>Document title</b> CMA_622A_CC_All_5_30 1E_LIN_MOST	
	<b>Document Type</b> DRAW/ELSY	<b>Release Status</b> RELEASED
	Volvo Document No 33445458	<b>Edited</b> May/22/2022
	<b>Issue</b> 030	<b>Page No</b> 40/149

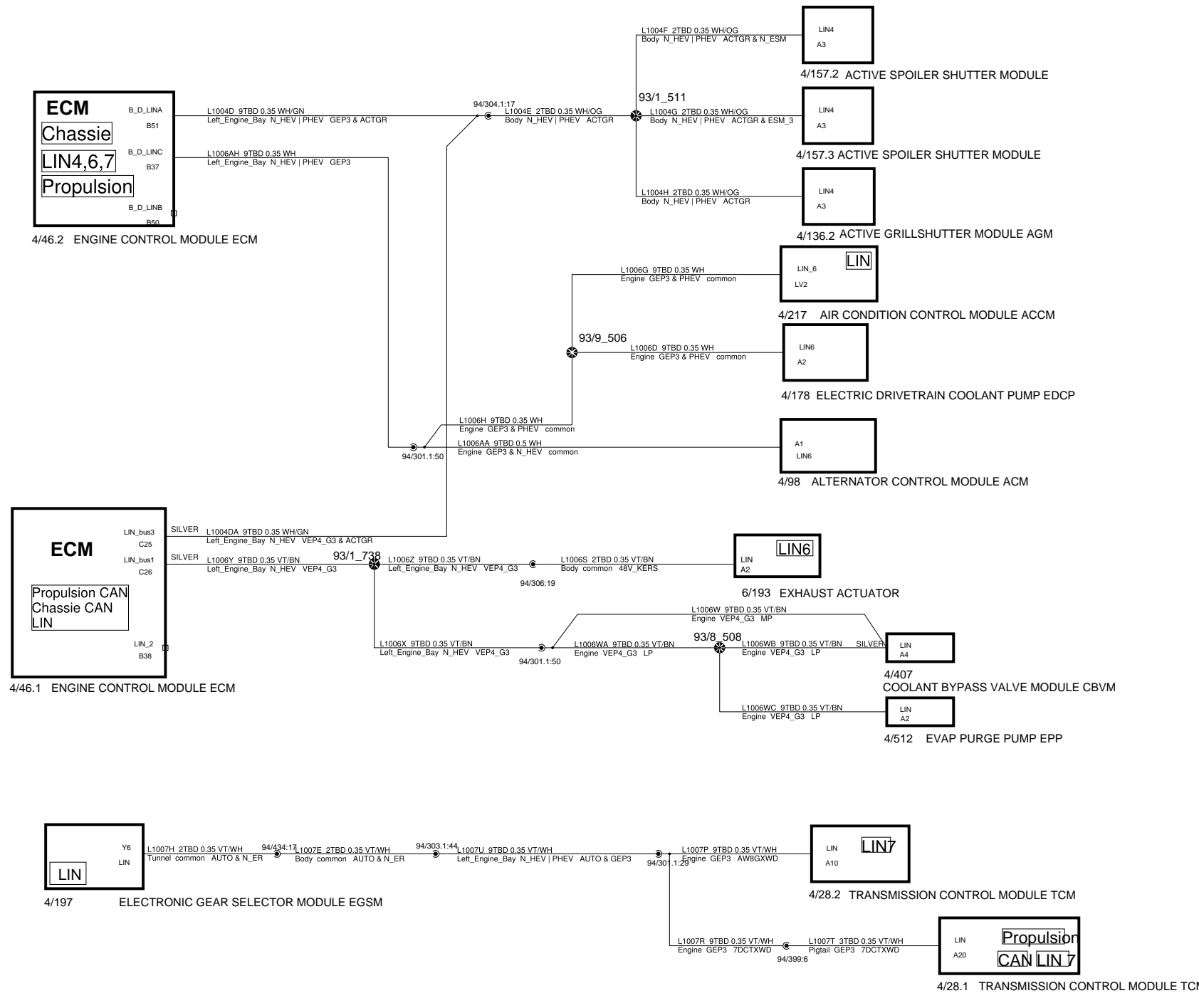

<p>The copying, distribution and utilization of this document as well as the communication of its contents to others without expressed authorization is prohibited. Offenders will be held liable for payment of damages. All rights reserved in the event of the grant of a patent, utility model or ornamental design registration.</p> <p><b>VOLVO</b> VOLVO CAR CORPORATION</p>	<b>Document title</b> CMA_622A_CC_All_5_30 1E_LIN_POWERTRAIN_N_BEV	
	<b>Document Type</b> DRAW/ELSY	<b>Release Status</b> RELEASED
	CEVT Document No 8888522365	<b>Edited</b> March/01/2022
	<b>Issue</b> 030	<b>Page No</b> 41/149

# 1F2 Accessories Alcolock Aftermarket - with and without Adapter harness

Wires shown on 1F2 Accessories Alcolock Preparation

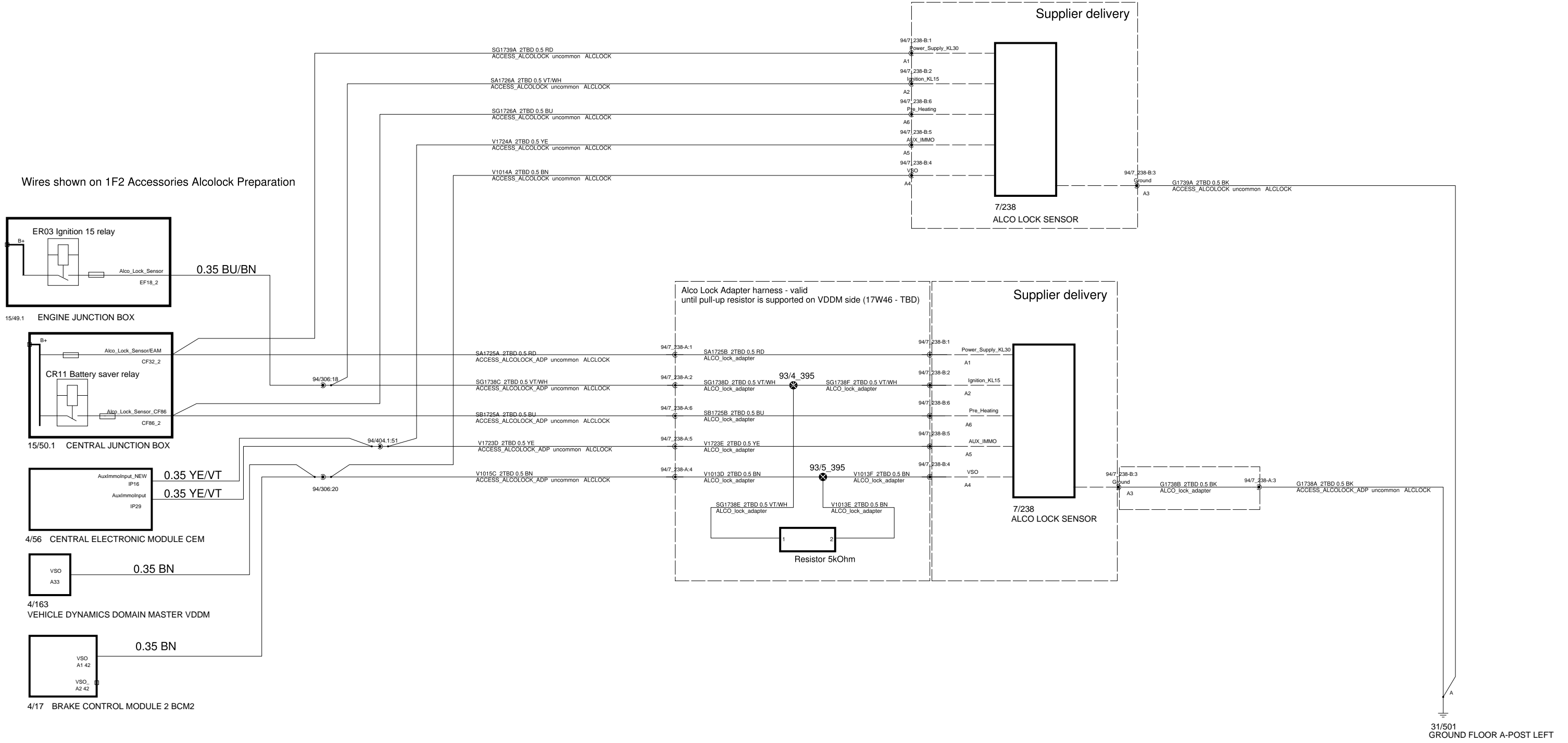

<p>The copying, distribution and utilization of this document as well as the communication of its contents to others without expressed authorization is prohibited. Offenders will be held liable for payment of damages. All rights reserved in the event of the grant of a patent, utility model or ornamental design registration.</p> <p><b>VOLVO</b> VOLVO CAR CORPORATION</p>	<b>Document title</b> CMA_622A_CC_All_5_30 1F1_Accessories_Alcolock_Aftermarket	
	<b>Document Type</b> DRAW/ELSY	<b>Release Status</b> RELEASED
	CEVT Document No 8888522365	<b>Edited</b> February/16/2022
	<b>Issue</b> 030	<b>Page No</b> 42/149

# 1F Accessories Preparation

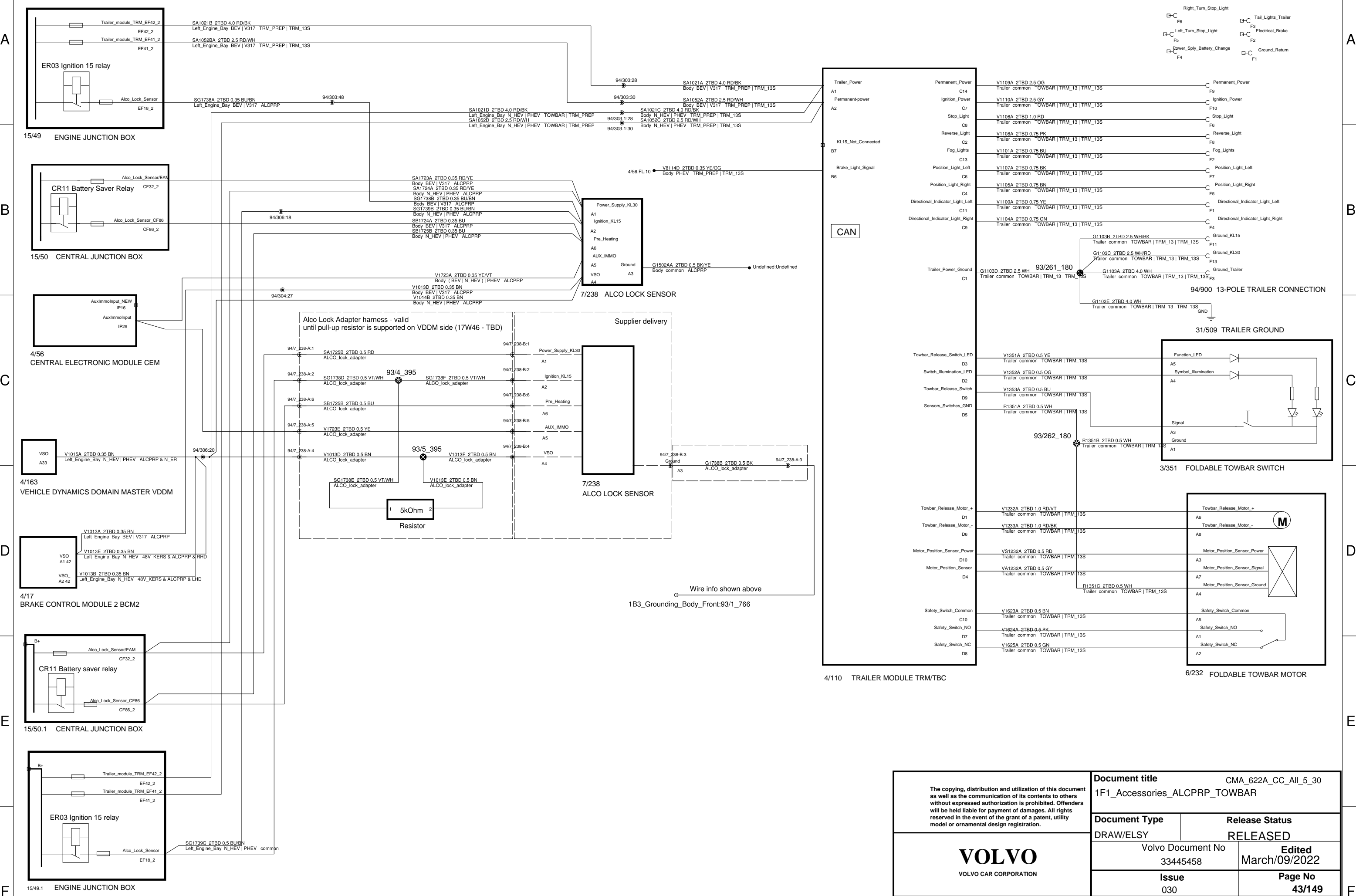

<p>The copying, distribution and utilization of this document as well as the communication of its contents to others without expressed authorization is prohibited. Offenders will be held liable for payment of damages. All rights reserved in the event of the grant of a patent, utility model or ornamental design registration.</p> <p><b>VOLVO</b> VOLVO CAR CORPORATION</p>		<p><b>Document title</b> CMA_622A_CC_All_5_30 1F1_Accessories_ALCPRP_TOWBAR</p>	
		<p><b>Document Type</b> DRAW/ELSY</p>	<p><b>Release Status</b> RELEASED</p>
		<p>Volvo Document No 33445458</p>	<p><b>Edited</b> March/09/2022</p>
		<p><b>Issue</b> 030</p>	<p><b>Page No</b> 43/149</p>

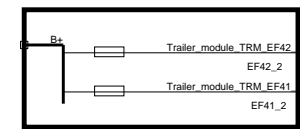

15/49 ENGINE JUNCTION BOX

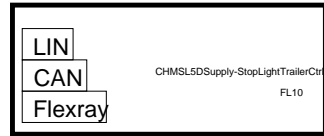

4/56 CENTRAL ELECTRONIC MODULE CEM

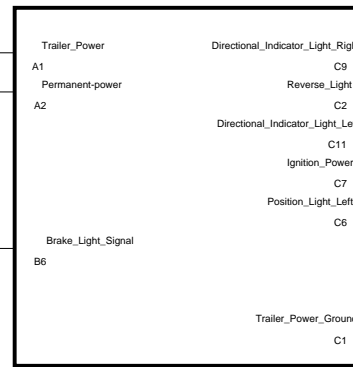

4/110 TRAILER MODULE TRM/TBC

94/900.1  
4/7-POLE TRAILER CONNECTION

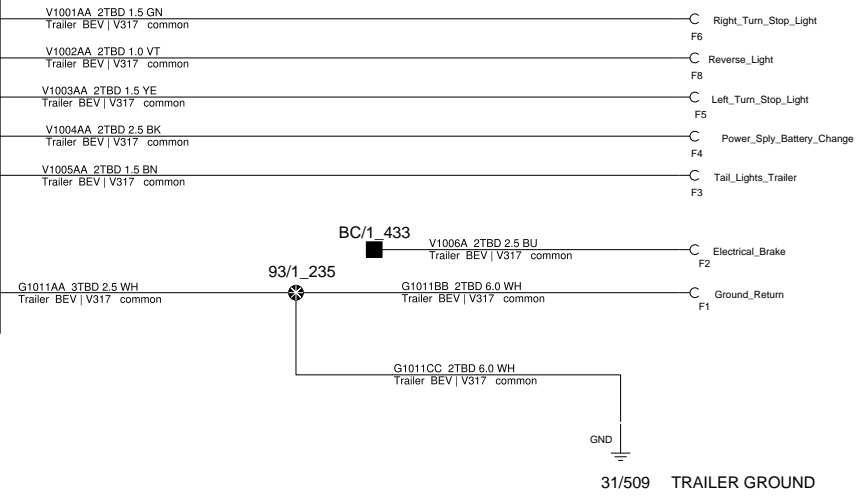

The copying, distribution and utilization of this document as well as the communication of its contents to others without expressed authorization is prohibited. Offenders will be held liable for payment of damages. All rights reserved in the event of the grant of a patent, utility model or ornamental design registration.

**VOLVO**  
VOLVO CAR CORPORATION

**Document title** CMA\_622A\_CC\_All\_5\_30  
1F2\_Assessories\_Towing\_System\_4/7-pole\_US

**Document Type** DRAW/ELSY  
**Release Status** RELEASED

CEVT Document No  
8888522365  
**Edited**  
June/16/2021

**Issue**  
030  
**Page No**  
44/149

# 1F3 Accessories Rear Park Assist Camera

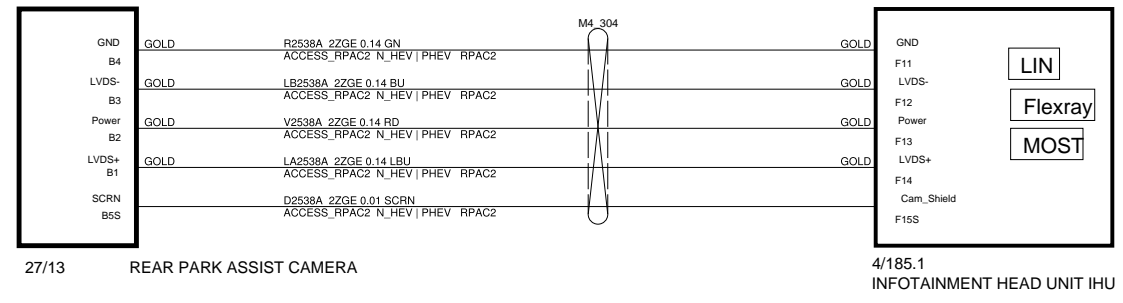

<p>The copying, distribution and utilization of this document as well as the communication of its contents to others without expressed authorization is prohibited. Offenders will be held liable for payment of damages. All rights reserved in the event of the grant of a patent, utility model or ornamental design registration.</p> <p><b>VOLVO</b> VOLVO CAR CORPORATION</p>	<b>Document title</b> CMA_622A_CC_All_5_30 1F3_Accessories_Rear_Park_Assist_Camera	
	<b>Document Type</b> DRAW/ELSY	<b>Release Status</b> RELEASED
	CEVT Document No 8888522365	<b>Edited</b> September/29/2020
	<b>Issue</b> 030	<b>Page No</b> 45/149

# 1F4 Accessories LED Illumination

## Passthrough 94/604 - (14pol)

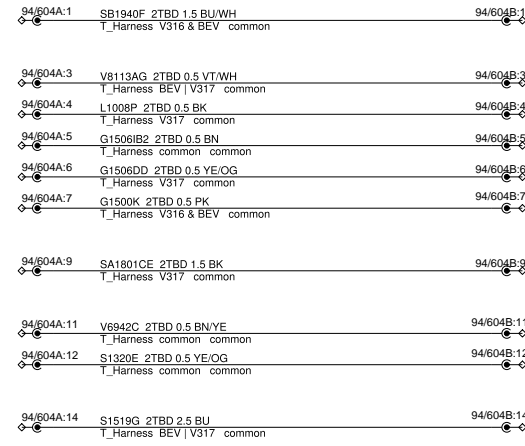

## Base Vehicle

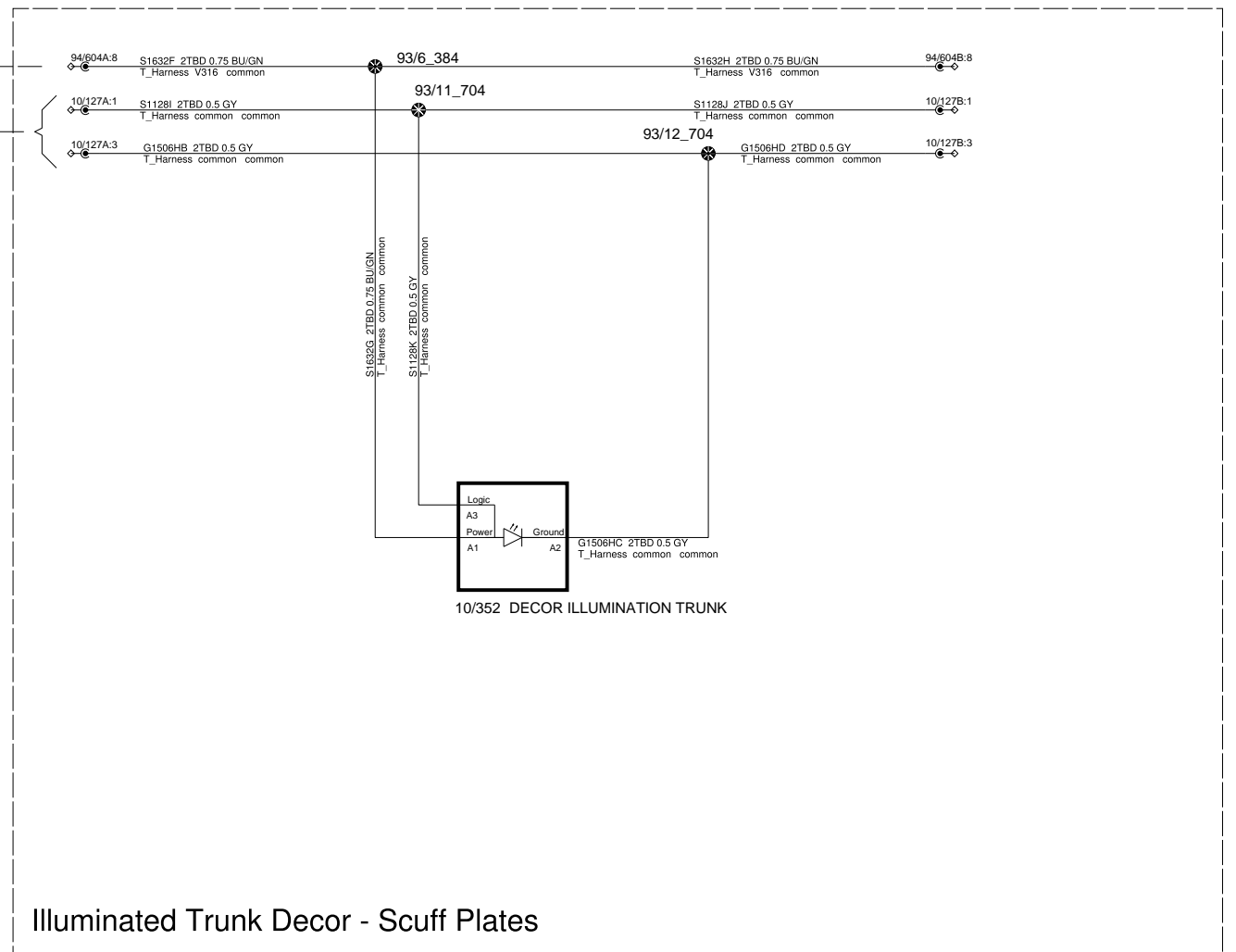
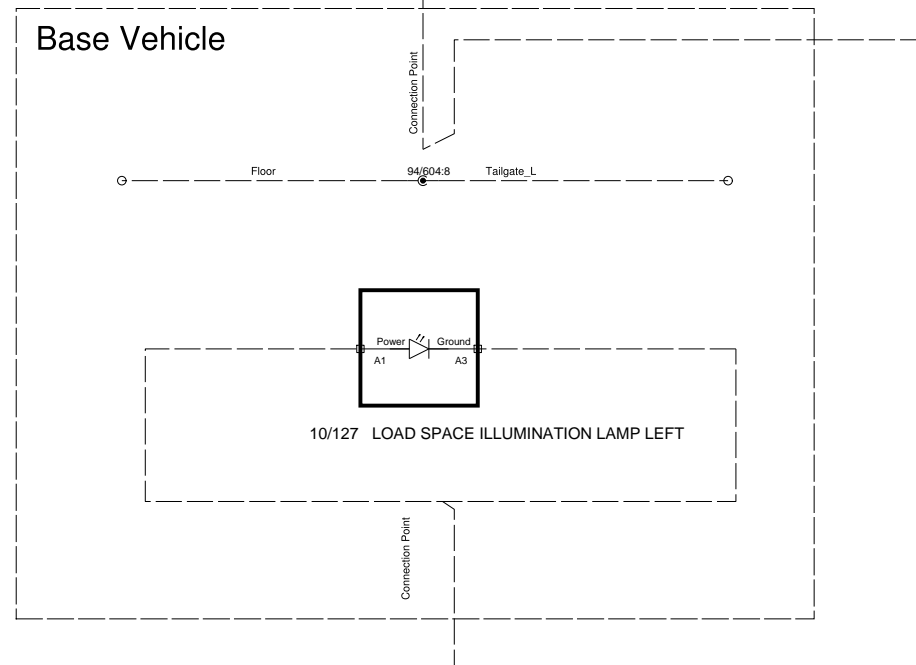

<p>The copying, distribution and utilization of this document as well as the communication of its contents to others without expressed authorization is prohibited. Offenders will be held liable for payment of damages. All rights reserved in the event of the grant of a patent, utility model or ornamental design registration.</p> <p><b>VOLVO</b> VOLVO CAR CORPORATION</p>	<b>Document title</b> CMA_622A_CC_A11_5_30 1F4_Accessories_LED_Illumination	
	<b>Document Type</b> DRAW/ELSY	<b>Release Status</b> RELEASED
	CEVT Document No 8888522365	<b>Edited</b> March/10/2022
	<b>Issue</b> 030	<b>Page No</b> 46/149

# 1F4 Accessories USB Hub Installation Aftermarket

Intended solution to provide USB Hub to replace USB1 functionality  
 [Valid up until structure 19W17]

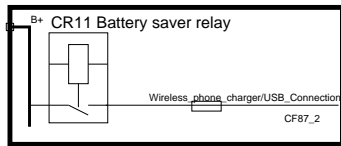

15/50.1 CENTRAL JUNCTION BOX

SB6055A 2TBD 0.5 RD  
 ACCESS\_USB\_HUB\_N\_HEV|PHEV USB\_1

G1379B 2TBD 0.5 BK  
 ACCESS\_USB\_HUB\_RHD USB\_1  
 G1380E 2TBD 0.5 BK  
 ACCESS\_USB\_HUB\_LHD USB\_1

31/402 GROUND IP A-POST RIGHT

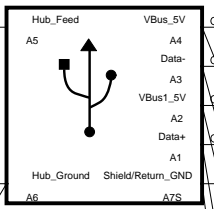

17/42.2 USB CONNECTION V

Wires shown on 7A Infotainment page

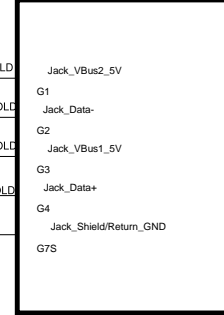
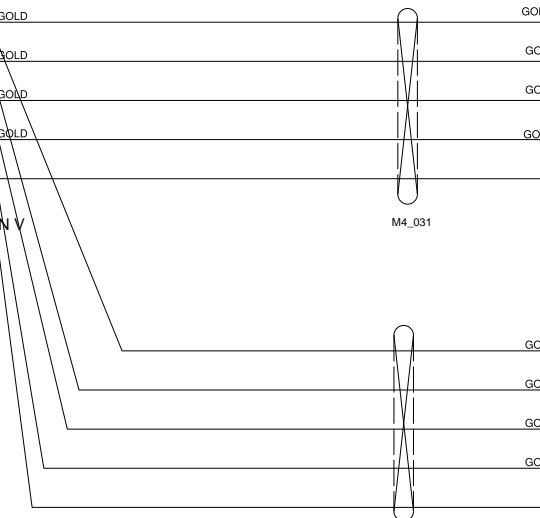

4/185 INFOTAINMENT HEAD UNIT IHU

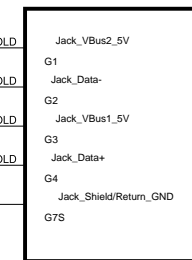

4/185.1 INFOTAINMENT HEAD UNIT IHU

<p>The copying, distribution and utilization of this document as well as the communication of its contents to others without expressed authorization is prohibited. Offenders will be held liable for payment of damages. All rights reserved in the event of the grant of a patent, utility model or ornamental design registration.</p> <p><b>VOLVO</b> VOLVO CAR CORPORATION</p>	<b>Document title</b> CMA_622A_CC_All_5_30 1F4_Accessories_USB_Hub_Installation_Aftermarket	
	<b>Document Type</b> DRAW/ELSY	<b>Release Status</b> RELEASED
	CEVT Document No 8888522365	<b>Edited</b> May/22/2022
	<b>Issue</b> 030	<b>Page No</b> 47/149



# 1F5 Accessories Steering Wheel Heating

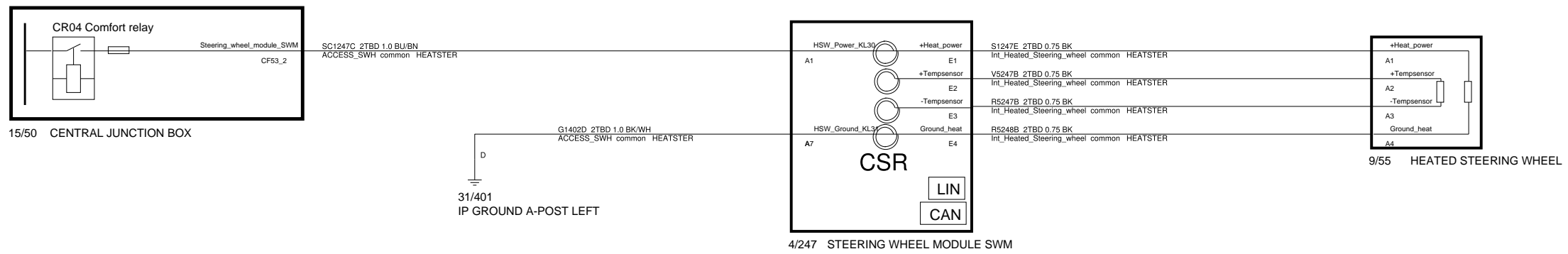

<p>The copying, distribution and utilization of this document as well as the communication of its contents to others without expressed authorization is prohibited. Offenders will be held liable for payment of damages. All rights reserved in the event of the grant of a patent, utility model or ornamental design registration.</p> <p><b>VOLVO</b> VOLVO CAR CORPORATION</p>	<b>Document title</b> CMA_622A_CC_All_5_30 1F5_Accessories_Steering_Wheel_Heating	
	<b>Document Type</b> DRAW/ELSY	<b>Release Status</b> RELEASED
	CEVT Document No 8888522365	<b>Edited</b> May/22/2022
	<b>Issue</b> 030	<b>Page No</b> 48/149

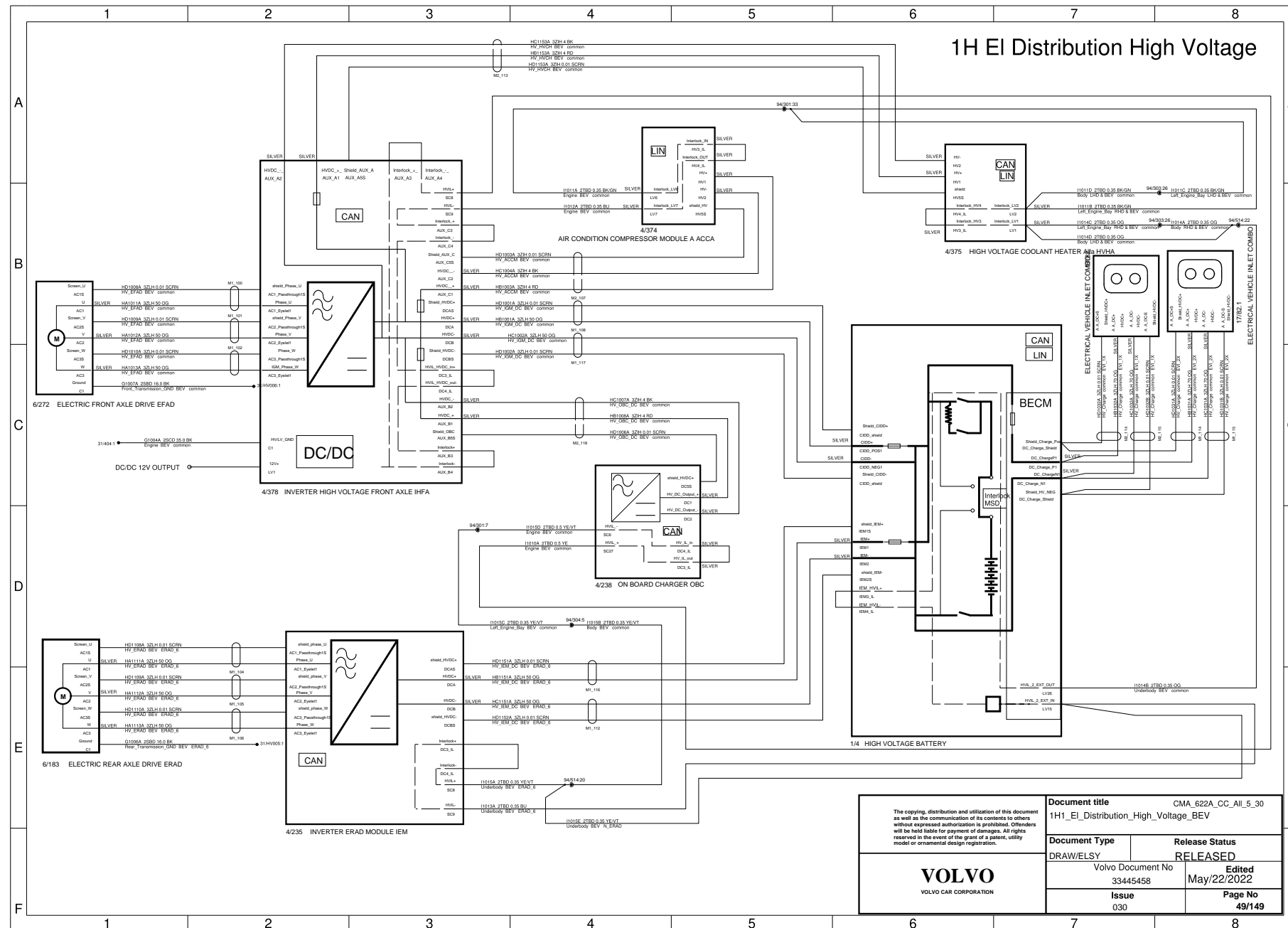

<p>The copying, distribution and utilization of this document as well as the communication of its contents to others without expressed authorization is prohibited. Offenders will be held liable for payment of damages. All rights reserved in the event of the grant of a patent, utility model or ornamental design registration.</p> <p><b>VOLVO</b> VOLVO CAR CORPORATION</p>		<p>Document title CMA_622A_CC_A11_5_30 1H1_EI_Distribution_High_Voltage_BEV</p>
<p>Document Type DRAW/ELSY</p>	<p>Release Status RELEASED</p>	<p>Issue 030</p>
<p>Volvo Document No 33445458</p>	<p>Edited May/22/2022</p>	<p>Page No 49/149</p>

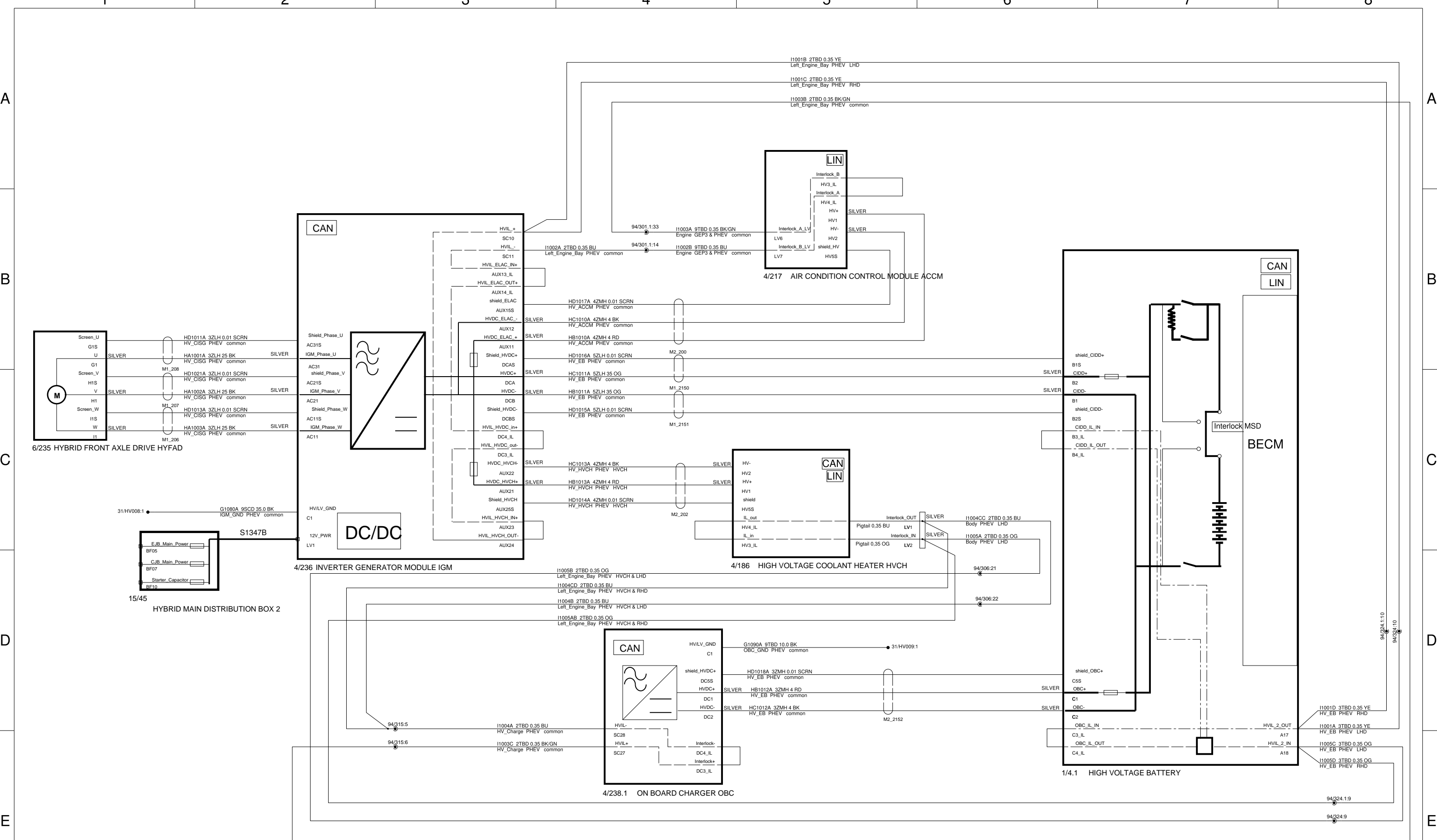

<p>The copying, distribution and utilization of this document as well as the communication of its contents to others without expressed authorization is prohibited. Offenders will be held liable for payment of damages. All rights reserved in the event of the grant of a patent, utility model or ornamental design registration.</p> <p><b>VOLVO</b> VOLVO CAR CORPORATION</p>		<p><b>Document title</b> CMA_622A_CC_All_5_30 1H2_EI_Distribution_High_Voltage_PHEV</p>	
		<p><b>Document Type</b> DRAW/ELSY</p>	<p><b>Release Status</b> RELEASED</p>
		<p>CEVT Document No 8888522365</p>	<p><b>Edited</b> March/18/2022</p>
		<p><b>Issue</b> 030</p>	<p><b>Page No</b> 50/149</p>

# 1K EI Energy Management High Voltage

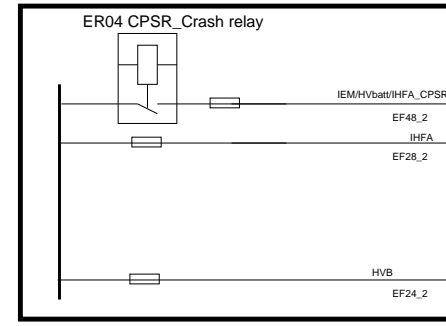

15/49 ENGINE JUNCTION BOX

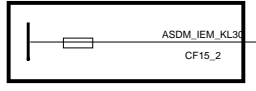

15/50 CENTRAL JUNCTION BOX

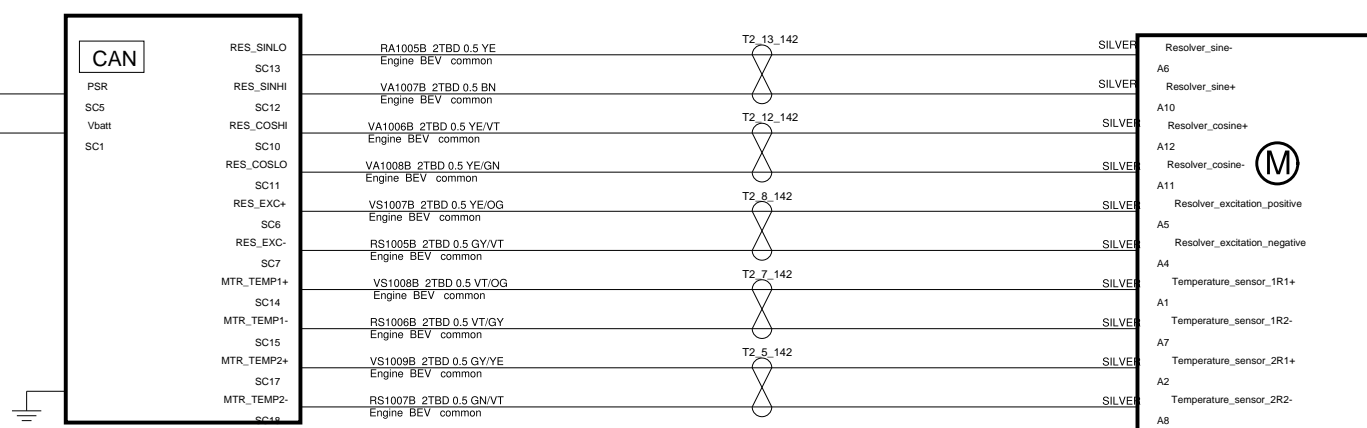

4/378 INVERTER HIGH VOLTAGE FRONT AXLE IHFA

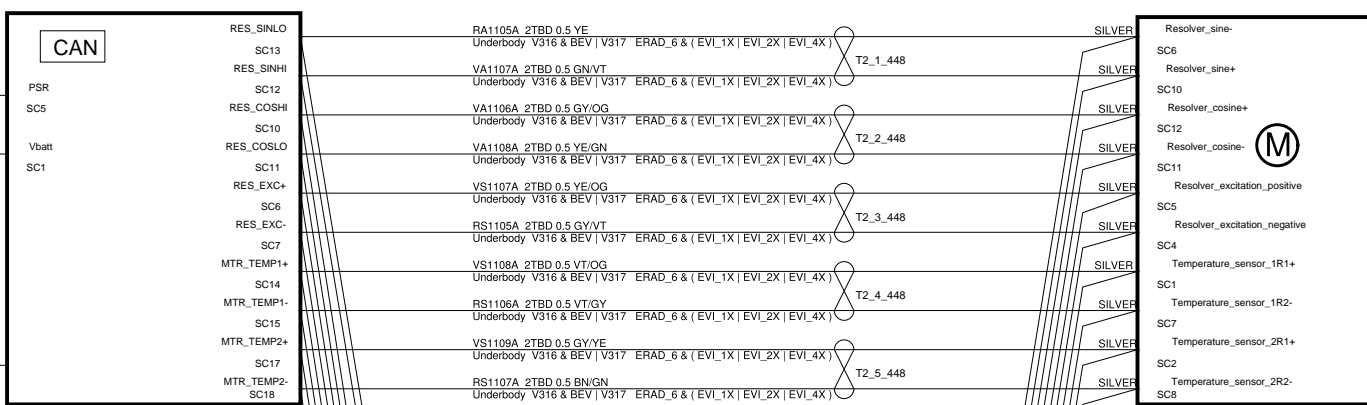

4/235 INVERTER ERAD MODULE IEM

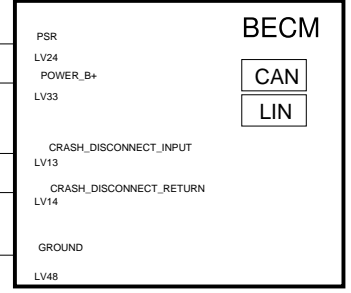

1/4 HIGH VOLTAGE BATTERY

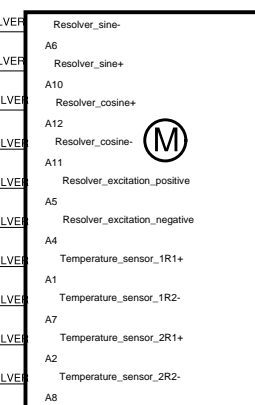

6/272 ELECTRIC FRONT AXLE DRIVE EFAD

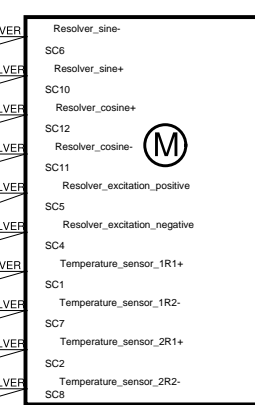

6/183 ELECTRIC REAR AXLE DRIVE ERAD

<p>The copying, distribution and utilization of this document as well as the communication of its contents to others without expressed authorization is prohibited. Offenders will be held liable for payment of damages. All rights reserved in the event of the grant of a patent, utility model or ornamental design registration.</p> <p><b>VOLVO</b> VOLVO CAR CORPORATION</p>		<p><b>Document title</b> CMA_622A_CC_All_5_30 1K1_EI_Energy_Management_High_Voltage_BEV</p>	
		<p><b>Document Type</b> DRAW/ELSY</p>	<p><b>Release Status</b> RELEASED</p>
<p>Volvo Document No 33445458</p>		<p><b>Edited</b> May/22/2022</p>	
<p><b>Issue</b> 030</p>		<p><b>Page No</b> 51/149</p>	

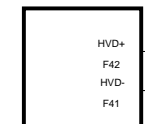

4/176 SUPPLEMENTARY RESTRAINT SYSTEM SRS

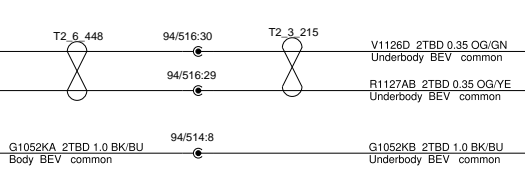

31/504.B:1

# 1K EI Energy Management High Voltage-China Market ARTEI-27579

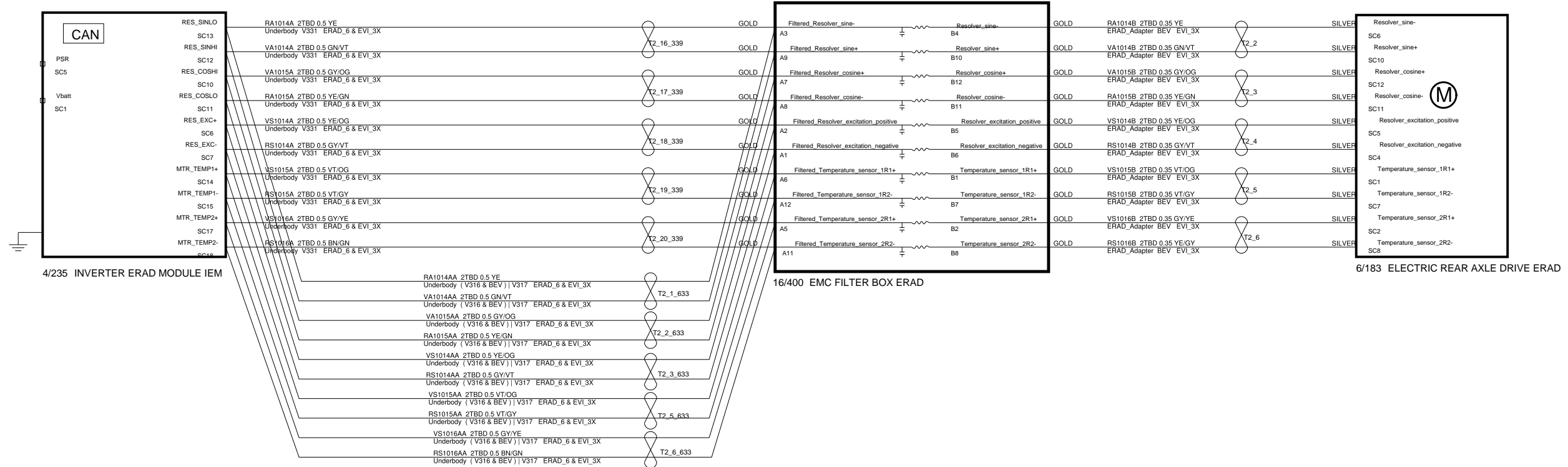

<p>The copying, distribution and utilization of this document as well as the communication of its contents to others without expressed authorization is prohibited. Offenders will be held liable for payment of damages. All rights reserved in the event of the grant of a patent, utility model or ornamental design registration.</p> <p><b>VOLVO</b> VOLVO CAR CORPORATION</p>	<p><b>Document title</b> CMA_622A_CC_All_5_30 1K2_EI_Energy_Managemnet_High_Voltage_BEV_3X</p>	
	<p><b>Document Type</b> DRAW/ELSY</p>	<p><b>Release Status</b> RELEASED</p>
	<p>CEVT Document No 8888522365</p>	<p><b>Edited</b> February/16/2022</p>
	<p><b>Issue</b> 030</p>	<p><b>Page No</b> 52/149</p>

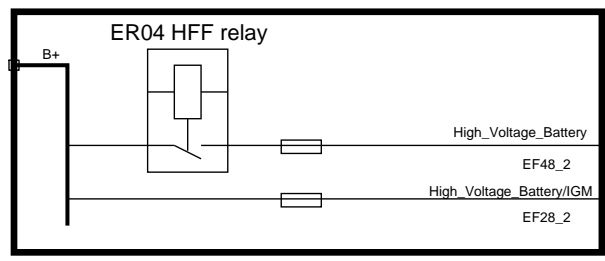

15/49.1 ENGINE JUNCTION BOX

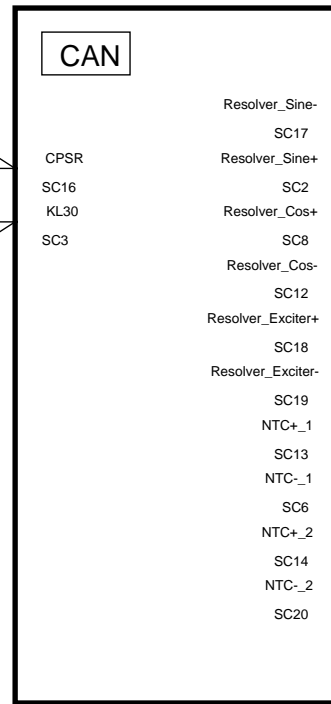
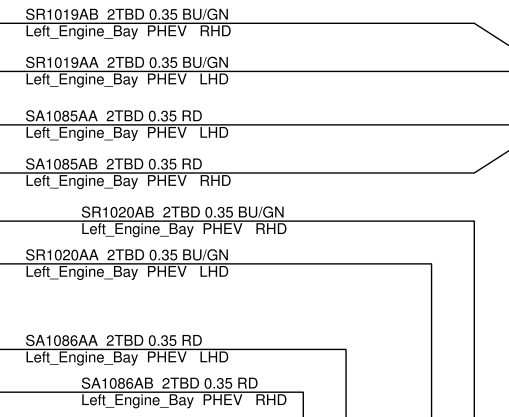

4/236 INVERTER GENERATOR MODULE IGM

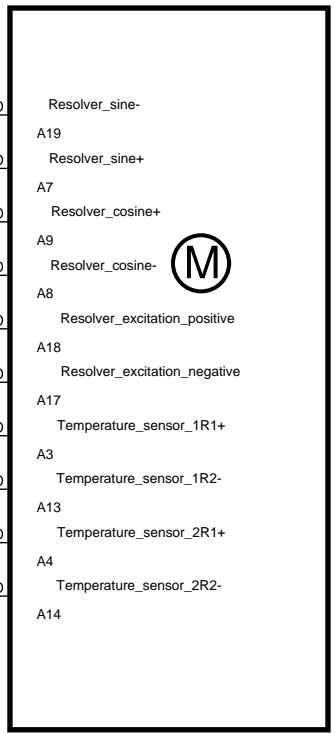
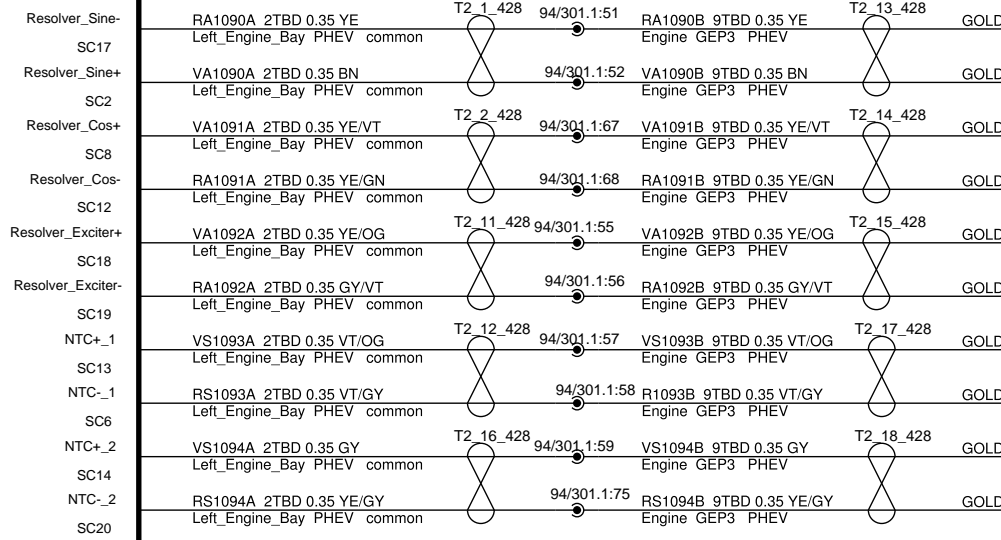

6/235 HYBRID FRONT AXLE DRIVE HYFAD

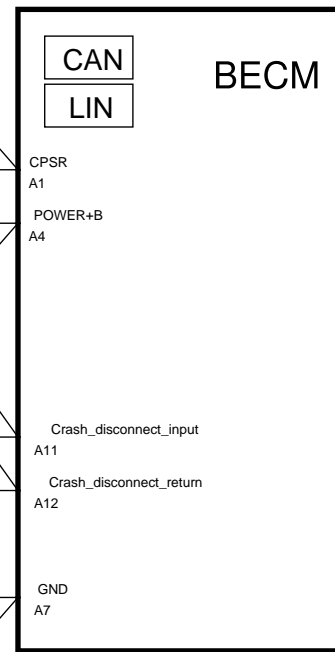

1/4.1 HIGH VOLTAGE BATTERY

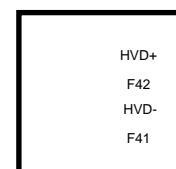

4/176 SUPPLEMENTARY RESTRAINT SYSTEM SRS

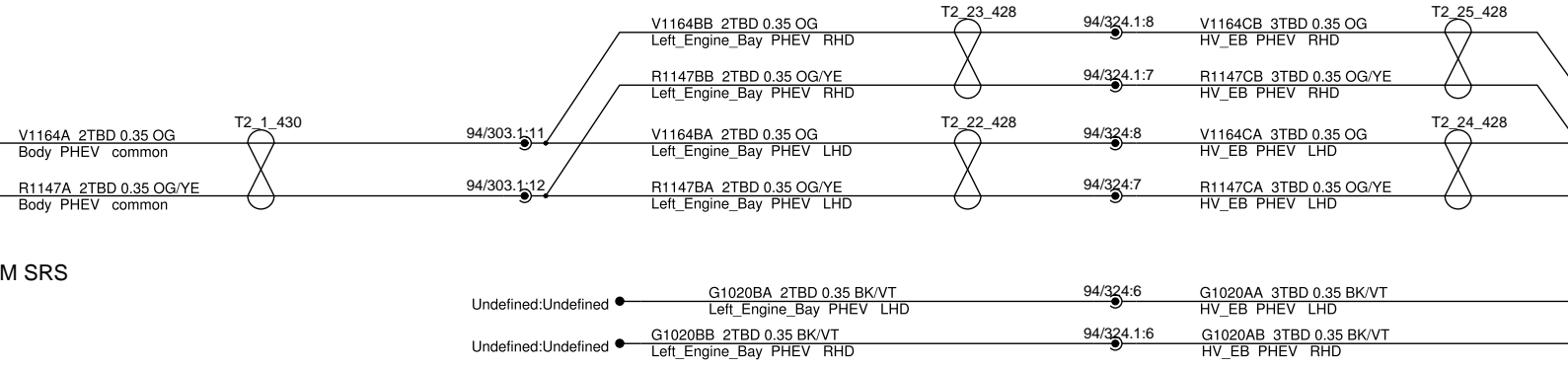

The copying, distribution and utilization of this document as well as the communication of its contents to others without expressed authorization is prohibited. Offenders will be held liable for payment of damages. All rights reserved in the event of the grant of a patent, utility model or ornamental design registration.



<b>Document title</b> CMA_622A_CC_All_5_30 1K3_EI_Energy_Management_High_Voltage_PHEV	
<b>Document Type</b> DRAW/ELSY	<b>Release Status</b> RELEASED
CEVT Document No 8888522365	<b>Edited</b> March/17/2022
<b>Issue</b> 030	<b>Page No</b> 53/149

### DC Charging wires in sheet 1H

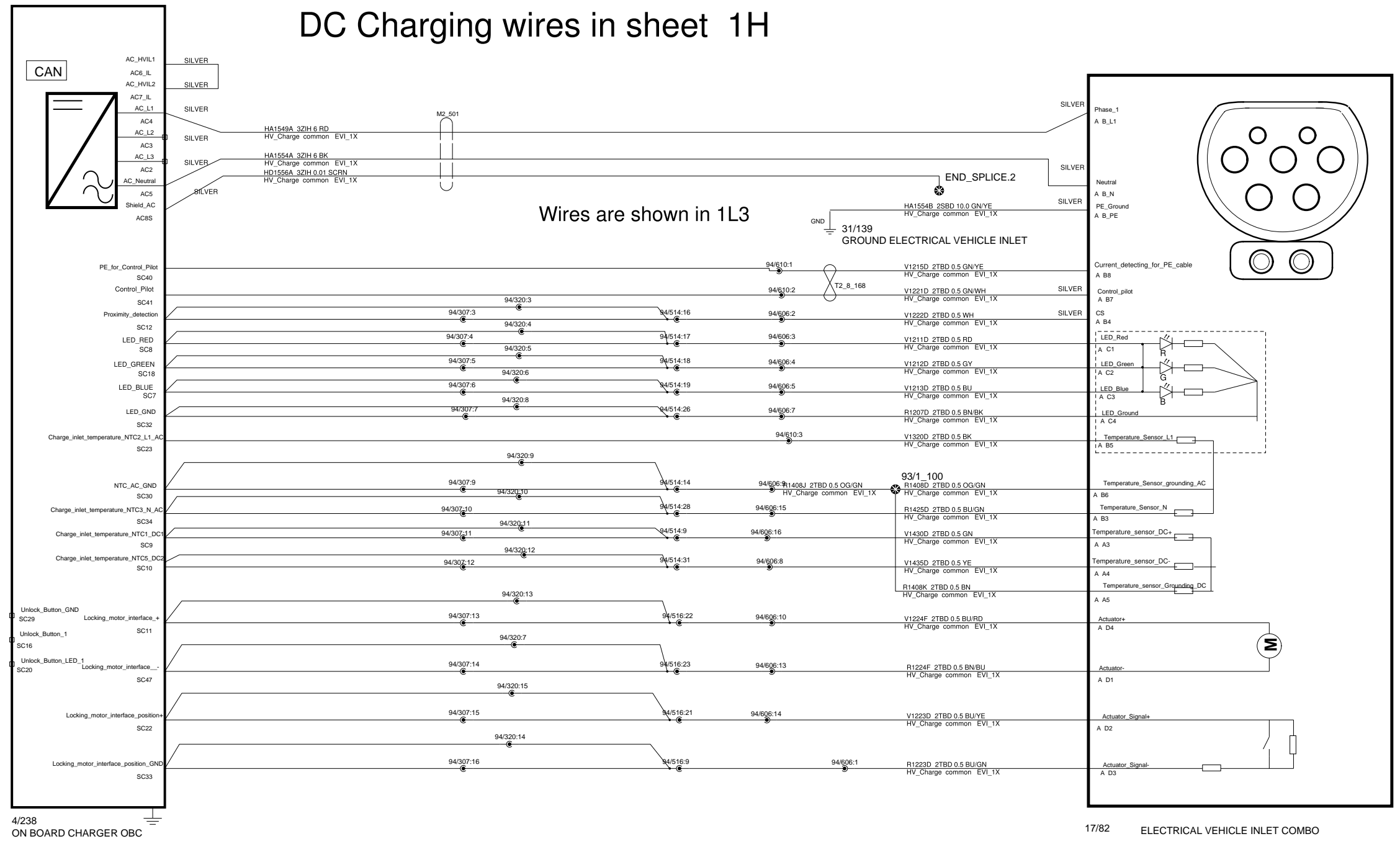

<p>The copying, distribution and utilization of this document as well as the communication of its contents to others without expressed authorization is prohibited. Offenders will be held liable for payment of damages. All rights reserved in the event of the grant of a patent, utility model or ornamental design registration.</p> <p><b>VOLVO</b> VOLVO CAR CORPORATION</p>	<p><b>Document title</b> CMA_622A_CC_All_5_30 1L1_EI_generating_public_network_1X</p>	
	<p><b>Document Type</b> DRAW/ELSY</p>	<p><b>Release Status</b> RELEASED</p>
	<p>CEVT Document No 8888522365</p>	<p><b>Edited</b> October/21/2021</p>
	<p><b>Issue</b> 030</p>	<p><b>Page No</b> 54/149</p>

# 1L3 EI generating public network

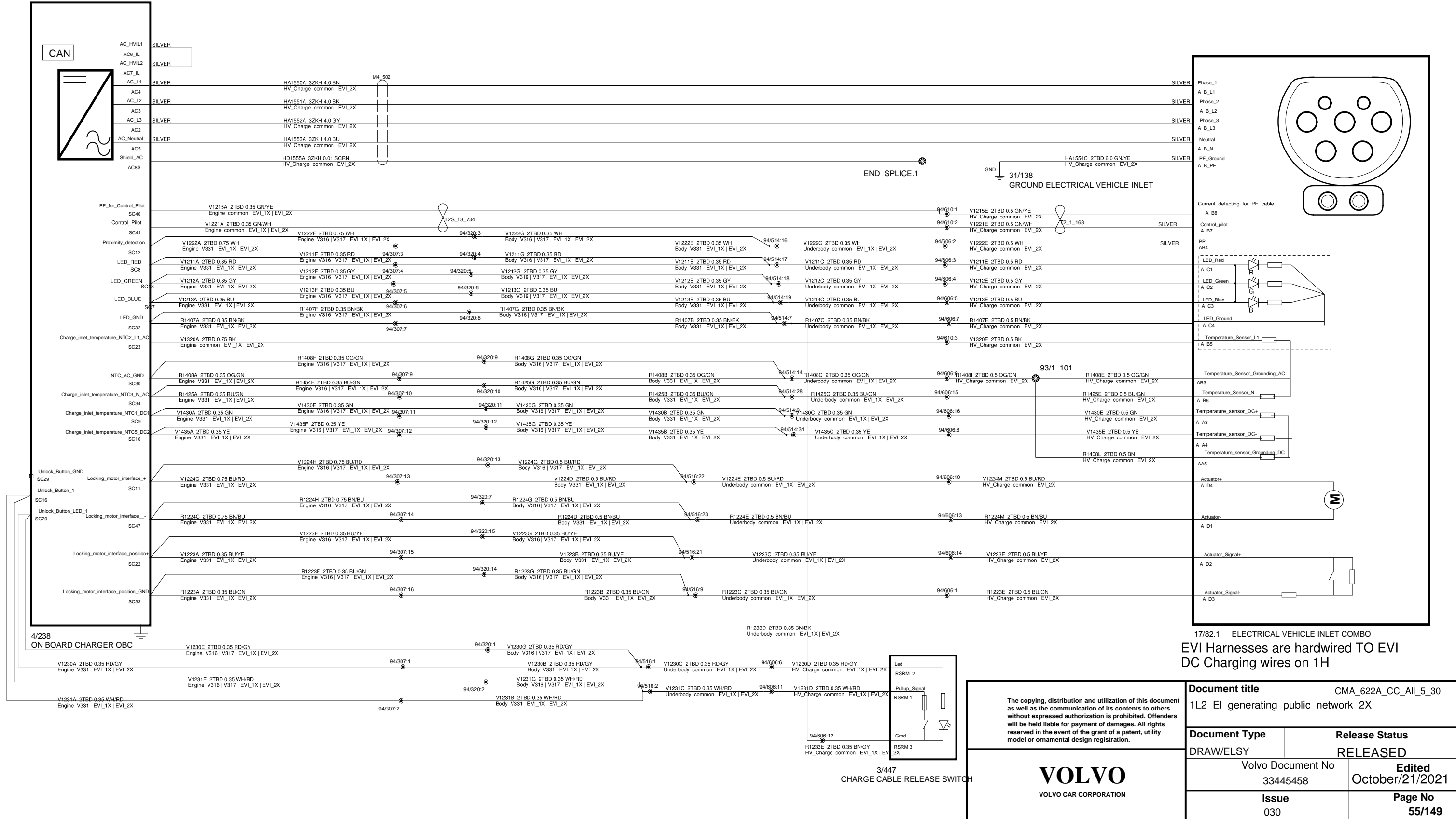

The copying, distribution and utilization of this document as well as the communication of its contents to others without expressed authorization is prohibited. Offenders will be held liable for payment of damages. All rights reserved in the event of the grant of a patent, utility model or ornamental design registration.

**VOLVO**  
VOLVO CAR CORPORATION

<b>Document title</b>		CMA_622A_CC_All_5_30	
1L2_EI_generating_public_network_2X			
<b>Document Type</b>	<b>Release Status</b>		
DRAW/ELSY	RELEASED		
Volvo Document No		<b>Edited</b>	
33445458		October/21/2021	
<b>Issue</b>		<b>Page No</b>	
030		55/149	



# 1L4 EI generating public network

EVI harnesses are hardwired to EVI

## GROUND ELECTRICAL VEHICAL INLET

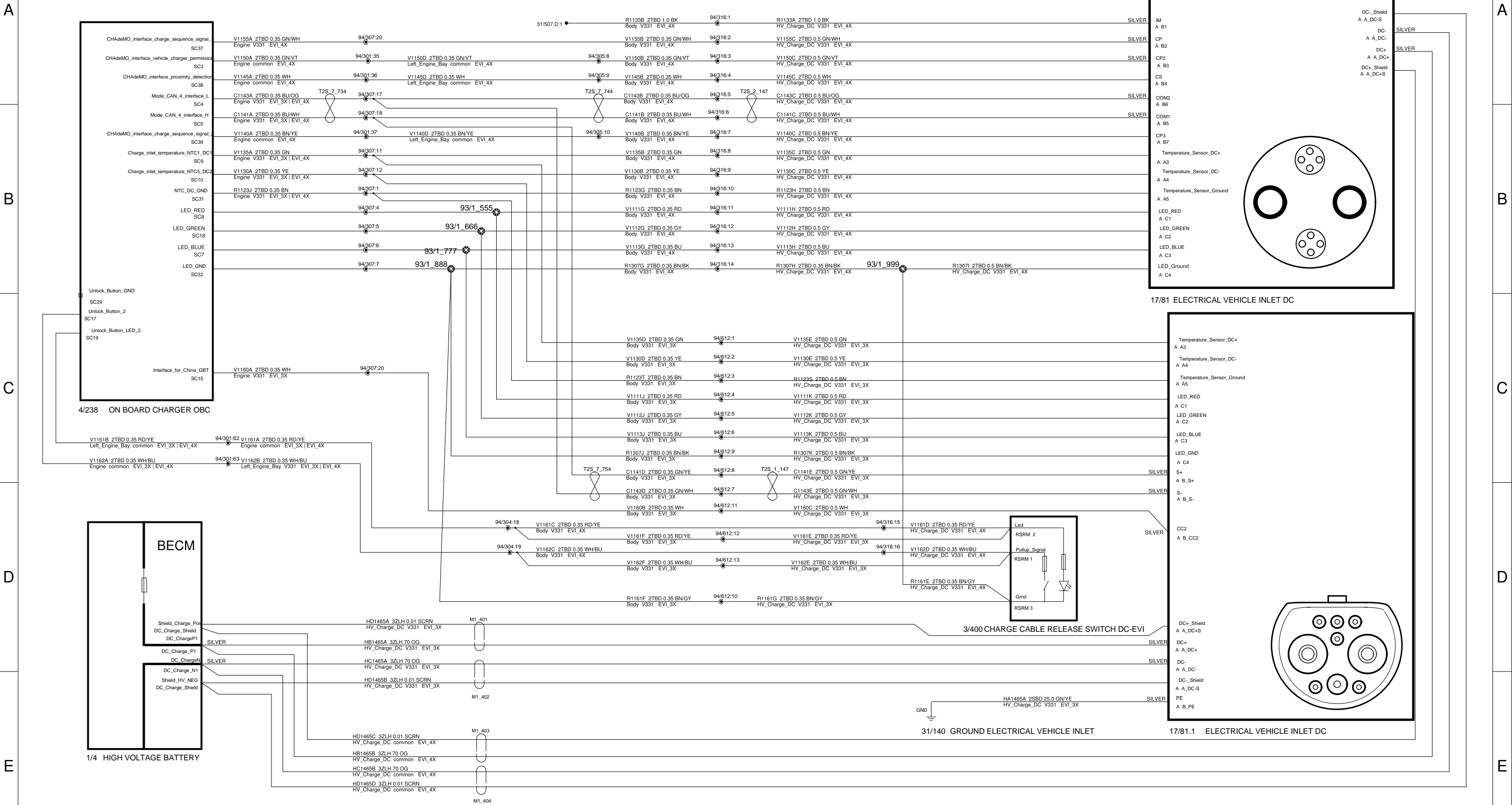

<p>The copying, distribution and utilization of this document as well as the communication of its contents to others without expressed authorization is prohibited. Offenders will be held liable for payment of damages. All rights reserved in the event of the grant of a patent, utility model or ornamental design registration.</p>		<p><b>Document title</b> CMA_622A_CC_All_5_30 1L3_EI_generating_public_network_V331_3X-4X_DC</p>	
		<p><b>Document Type</b> DRAW/ELSY</p>	<p><b>Release Status</b> RELEASED</p>
<p><b>VOLVO</b> VOLVO CAR CORPORATION</p>		<p>CEVT Document No 8888522365</p>	<p><b>Edited</b> February/17/2022</p>
		<p><b>Issue</b> 030</p>	<p><b>Page No</b> 56/149</p>

# 1L7 EI generating public network

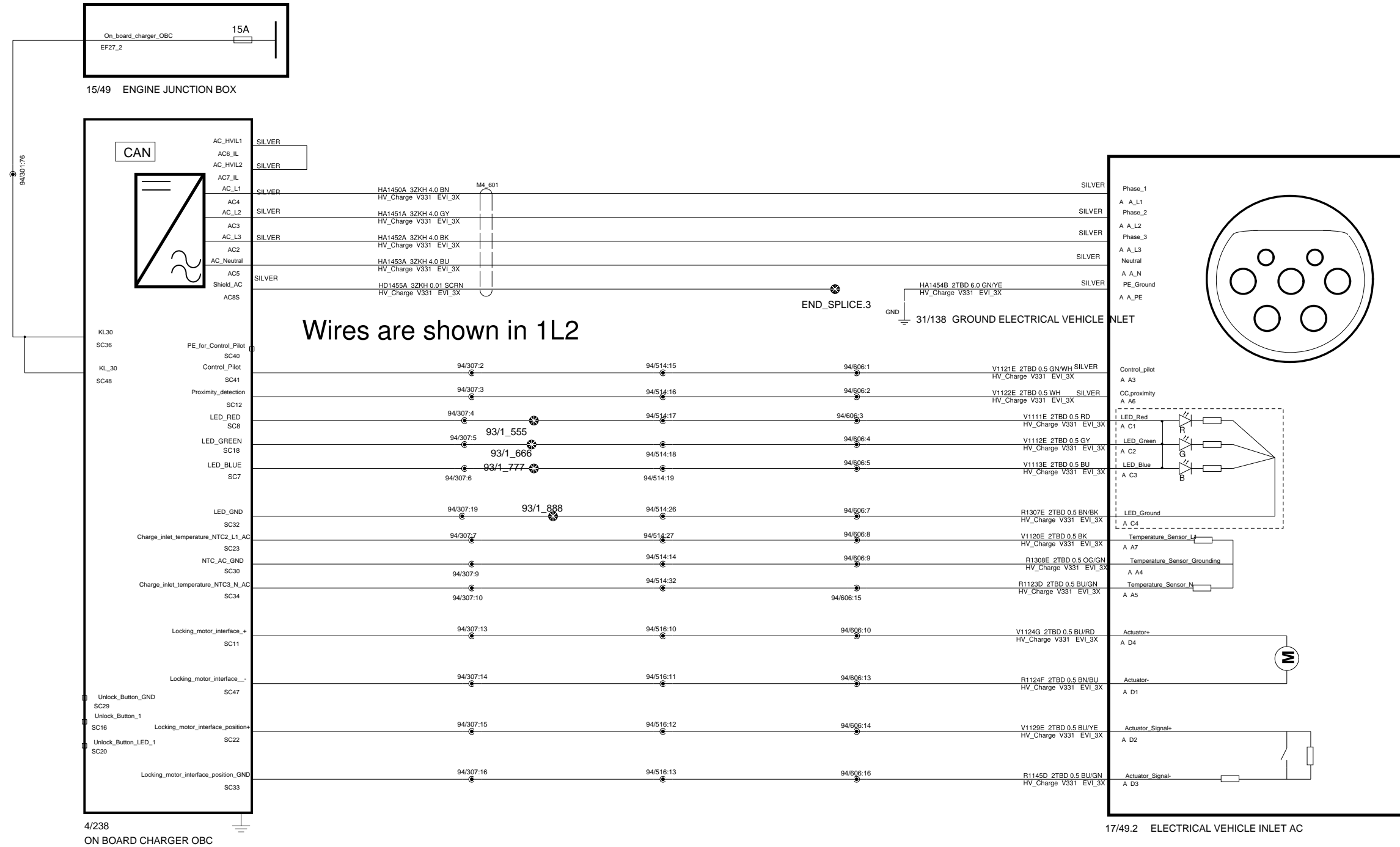

<p>The copying, distribution and utilization of this document as well as the communication of its contents to others without expressed authorization is prohibited. Offenders will be held liable for payment of damages. All rights reserved in the event of the grant of a patent, utility model or ornamental design registration.</p> <p><b>VOLVO</b> VOLVO CAR CORPORATION</p>	<b>Document title</b> CMA_622A_CC_All_5_30 1L4_EI_generating_public_network_V331_3X_AC	
	<b>Document Type</b> DRAW/ELSY	<b>Release Status</b> RELEASED
	CEVT Document No 8888522365	<b>Edited</b> October/01/2021
	<b>Issue</b> 030	<b>Page No</b> 57/149

# 1L2 EI generating public network



<p>The copying, distribution and utilization of this document as well as the communication of its contents to others without expressed authorization is prohibited. Offenders will be held liable for payment of damages. All rights reserved in the event of the grant of a patent, utility model or ornamental design registration.</p>		<p><b>Document title</b> CMA_622A_CC_All_5_30 1L5_EI_generating_public_network_V331_4X_AC</p>	
<p><b>Document Type</b> DRAW/ELSY</p>		<p><b>Release Status</b> RELEASED</p>	
<p><b>Volvo Document No</b> 33445458</p>		<p><b>Edited</b> March/09/2022</p>	
<p><b>Issue</b> 030</p>		<p><b>Page No</b> 58/149</p>	



# 1L6 EI generating public network

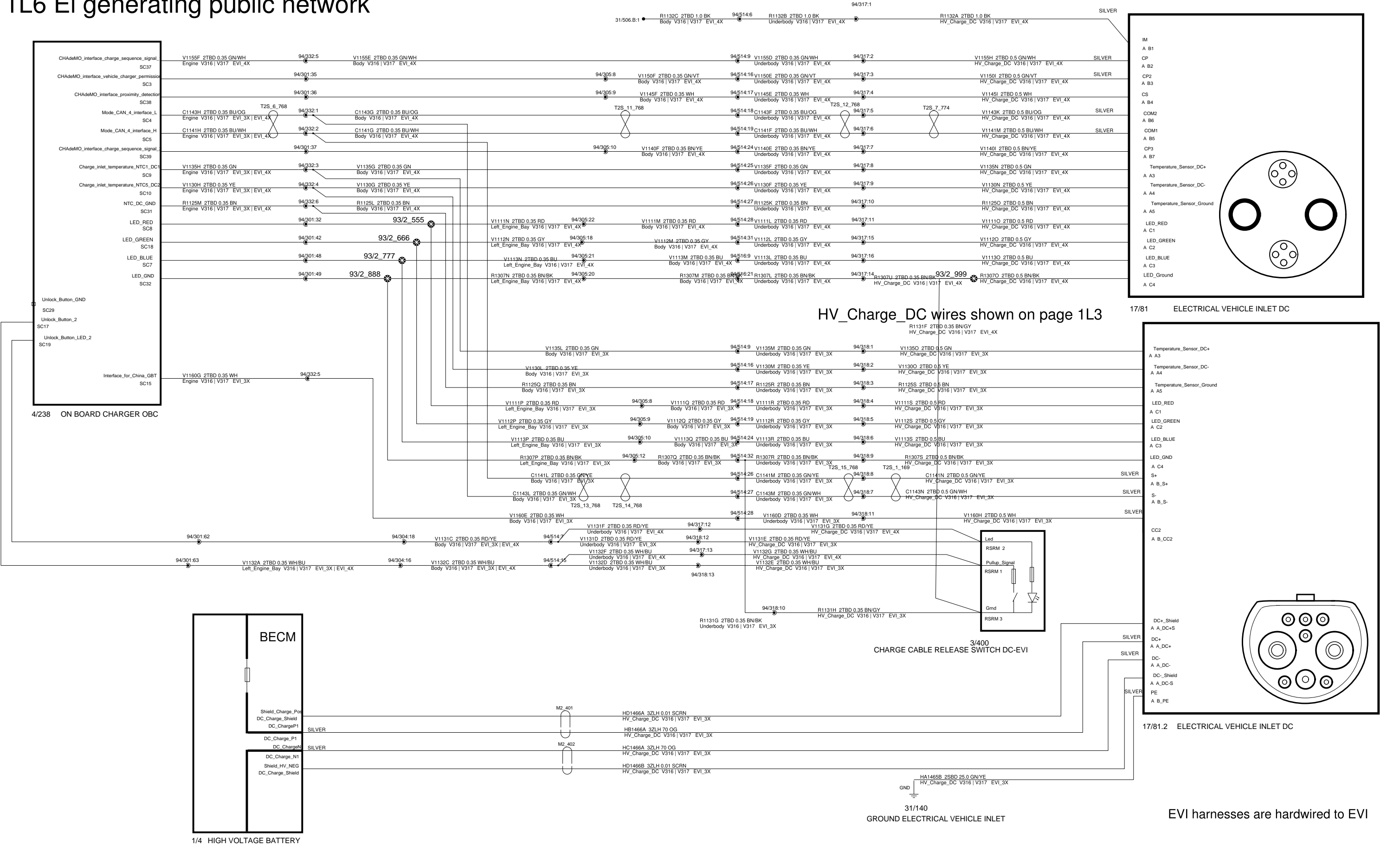

HV\_Charge\_DC wires shown on page 1L3

<p>The copying, distribution and utilization of this document as well as the communication of its contents to others without expressed authorization is prohibited. Offenders will be held liable for payment of damages. All rights reserved in the event of the grant of a patent, utility model or ornamental design registration.</p>		<p>Document title CMA_622A_CC_All_5_30 1L6_EI_generating_public_network_V316_V317_3X-4X_DC</p>	
		<p>Document Type DRAW/ELSY</p>	<p>Release Status RELEASED</p>
<p>VOLVO VOLVO CAR CORPORATION</p>		<p>CEVT Document No 8888522365</p>	<p>Edited February/17/2022</p>
		<p>Issue 030</p>	<p>Page No 59/149</p>

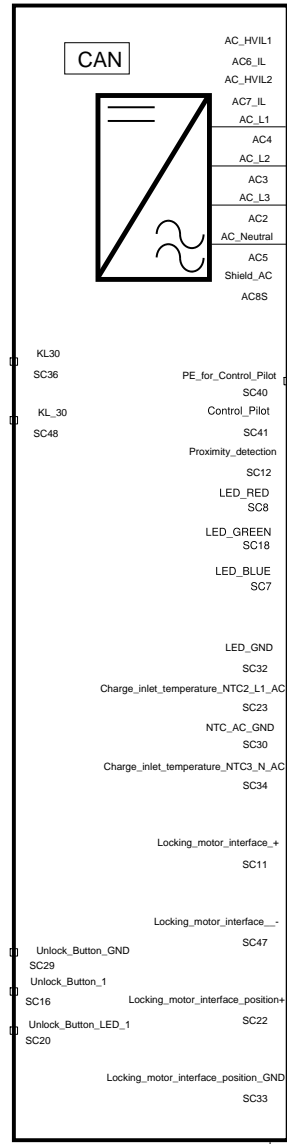

4/238  
ON BOARD CHARGER OBC

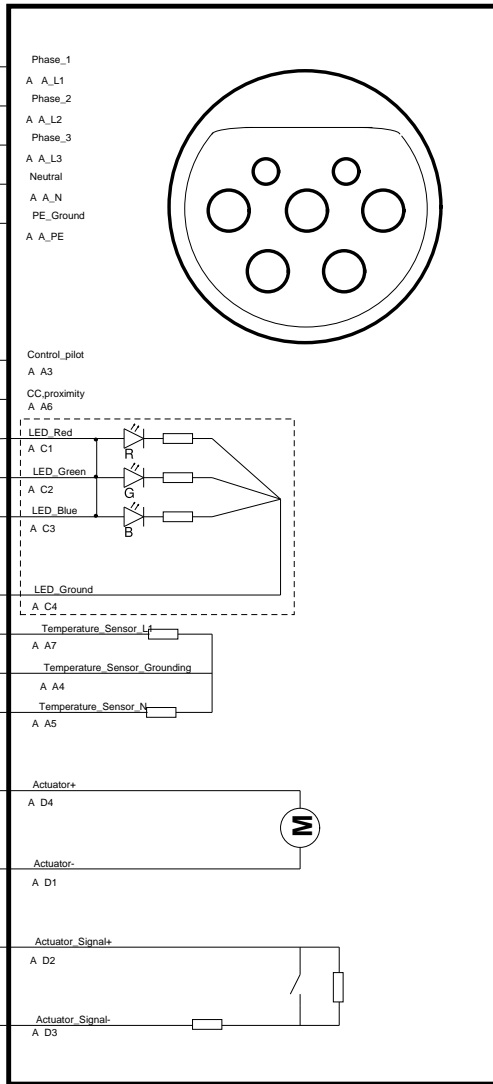
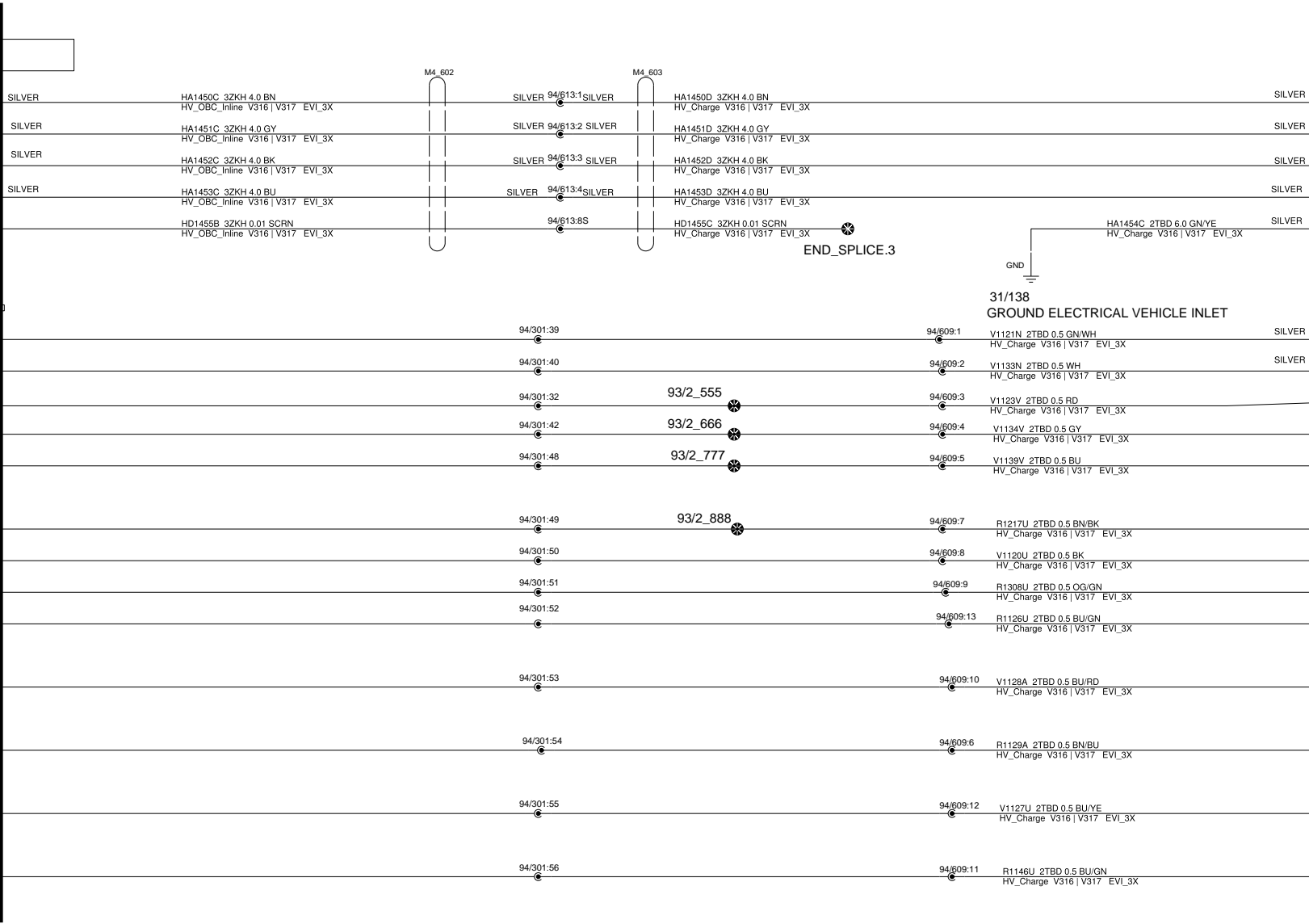

17/49.3  
ELECTRICAL VEHICLE INLET AC

<p>The copying, distribution and utilization of this document as well as the communication of its contents to others without expressed authorization is prohibited. Offenders will be held liable for payment of damages. All rights reserved in the event of the grant of a patent, utility model or ornamental design registration.</p> <p><b>VOLVO</b> VOLVO CAR CORPORATION</p>	<p><b>Document title</b> CMA_622A_CC_All_5_30 1L7_EI_generating_public_network_V316_V317_3X_AC</p>	
	<p><b>Document Type</b> DRAW/ELSY</p>	<p><b>Release Status</b> RELEASED</p>
	<p>CEVT Document No 8888522365</p>	<p><b>Edited</b> June/16/2021</p>
	<p><b>Issue</b> 030</p>	<p><b>Page No</b> 60/149</p>

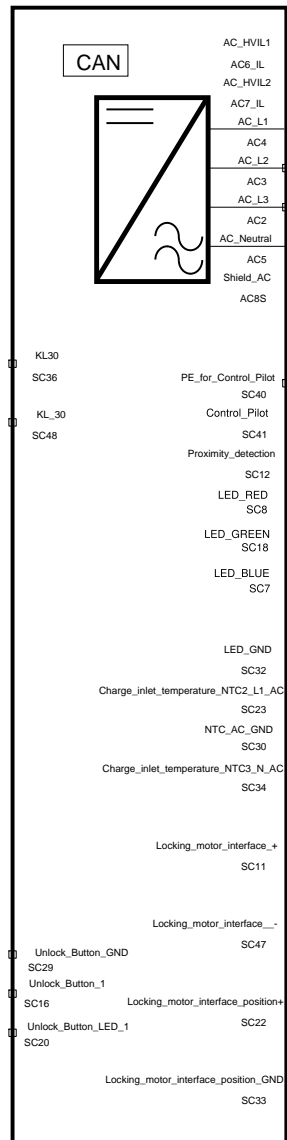

4/238  
ON BOARD CHARGER OBC

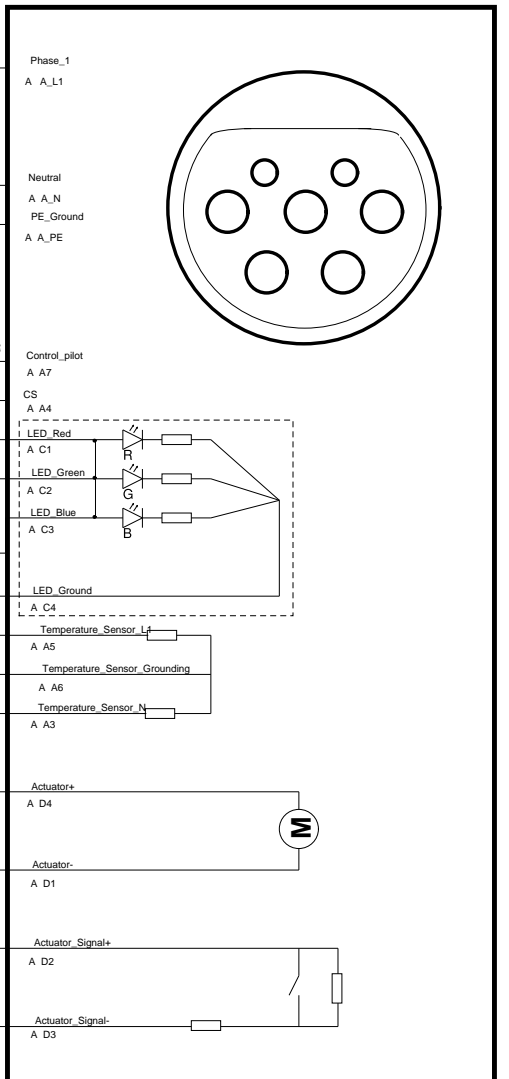
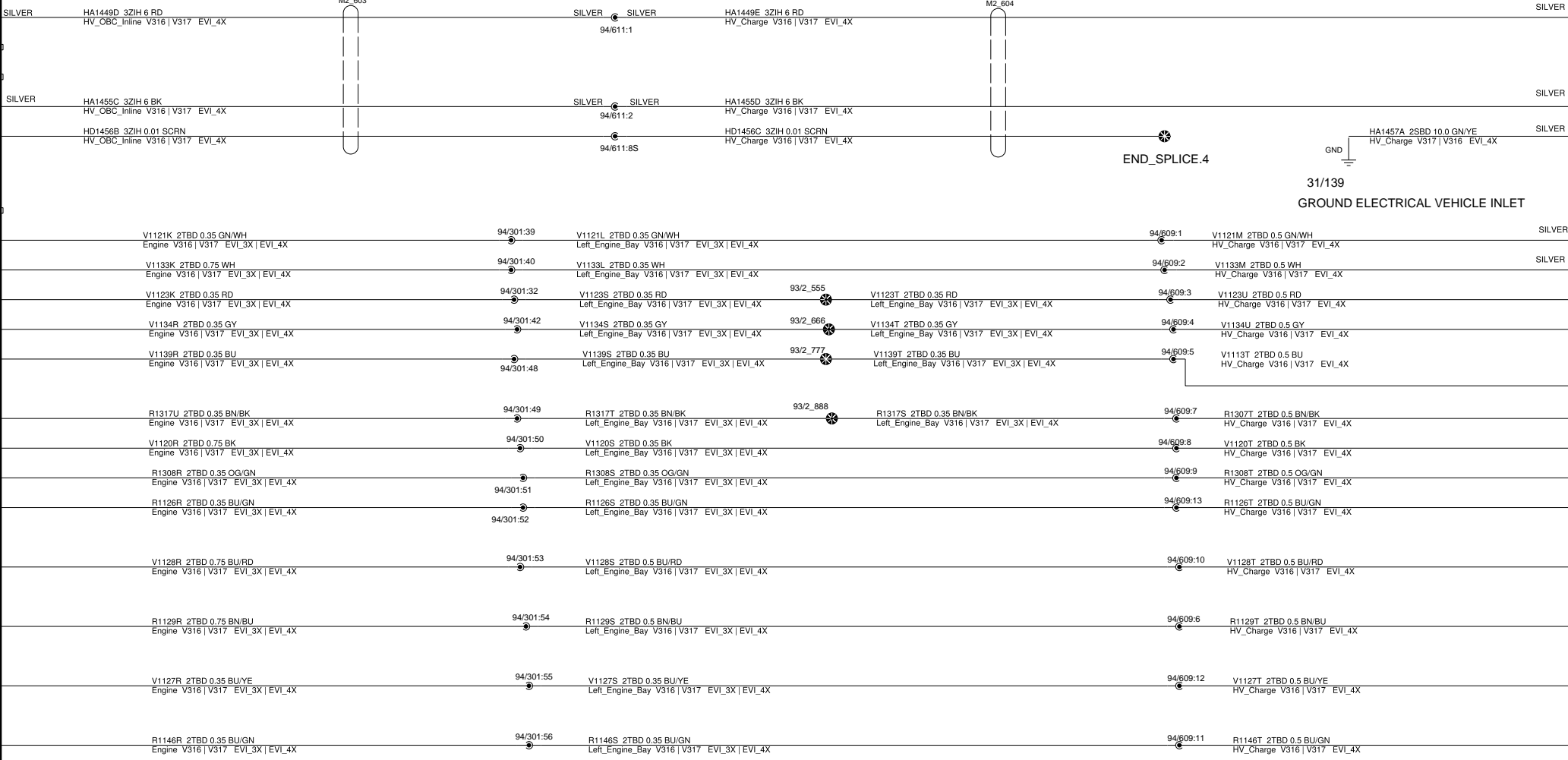

17/49 ELECTRICAL VEHICLE INLET AC

<p>The copying, distribution and utilization of this document as well as the communication of its contents to others without expressed authorization is prohibited. Offenders will be held liable for payment of damages. All rights reserved in the event of the grant of a patent, utility model or ornamental design registration.</p> <p><b>VOLVO</b> VOLVO CAR CORPORATION</p>	<b>Document title</b> CMA_622A_CC_All_5_30 1L8_EI_generating_public_network_V316_V317_4X_AC	
	<b>Document Type</b> DRAW/ELSY	<b>Release Status</b> RELEASED
	CEVT Document No 8888522365	<b>Edited</b> June/16/2021
	<b>Issue</b> 030	<b>Page No</b> 61/149

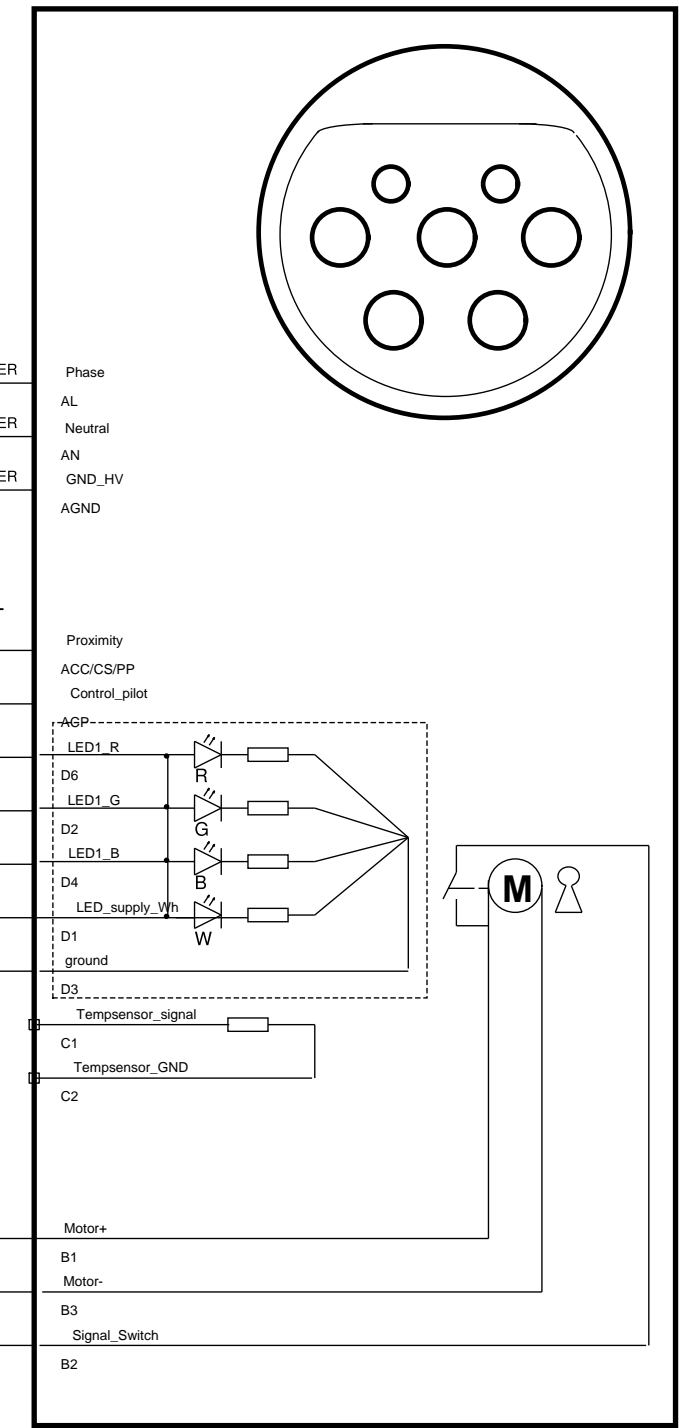
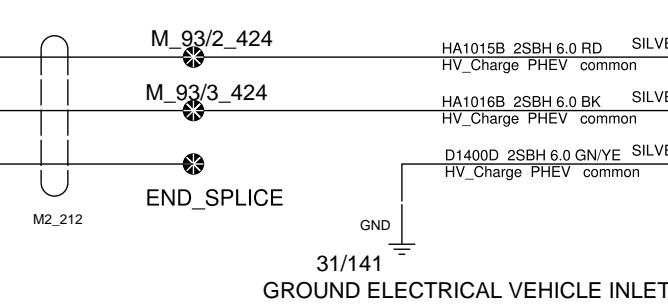
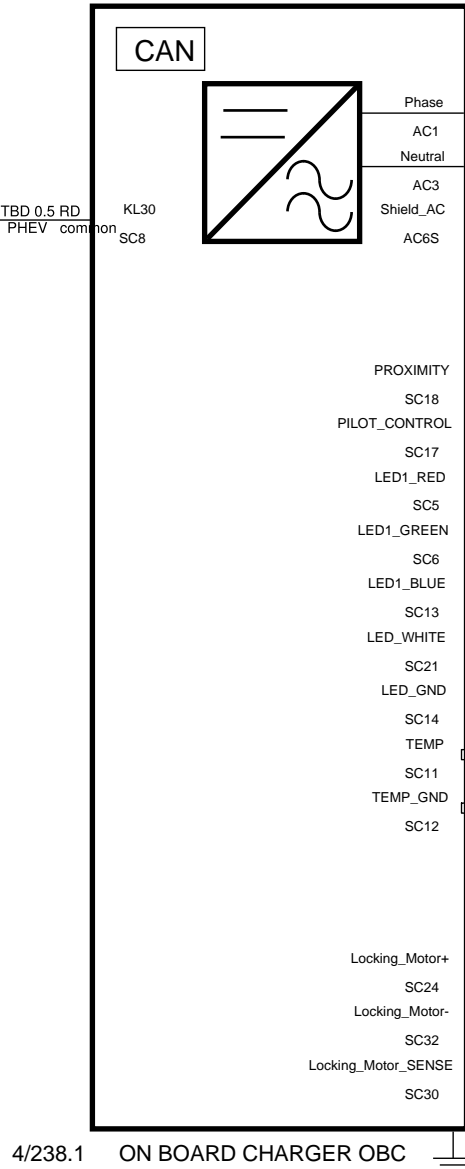
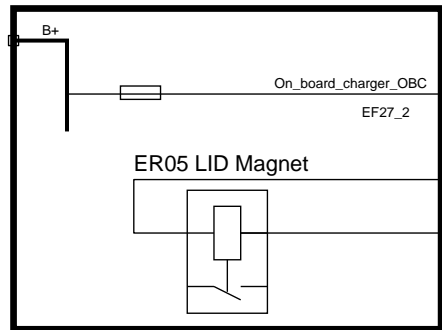

<p>The copying, distribution and utilization of this document as well as the communication of its contents to others without expressed authorization is prohibited. Offenders will be held liable for payment of damages. All rights reserved in the event of the grant of a patent, utility model or ornamental design registration.</p> <p><b>VOLVO</b> VOLVO CAR CORPORATION</p>	<p><b>Document title</b> CMA_622A_CC_All_5_30 1L9_EI_generating_public_network_V316_PHEV</p>	
	<p><b>Document Type</b> DRAW/ELSY</p>	<p><b>Release Status</b> RELEASED</p>
	<p>CEVT Document No 8888522365</p>	<p><b>Edited</b> March/16/2022</p>
	<p><b>Issue</b> 030</p>	<p><b>Page No</b> 62/149</p>

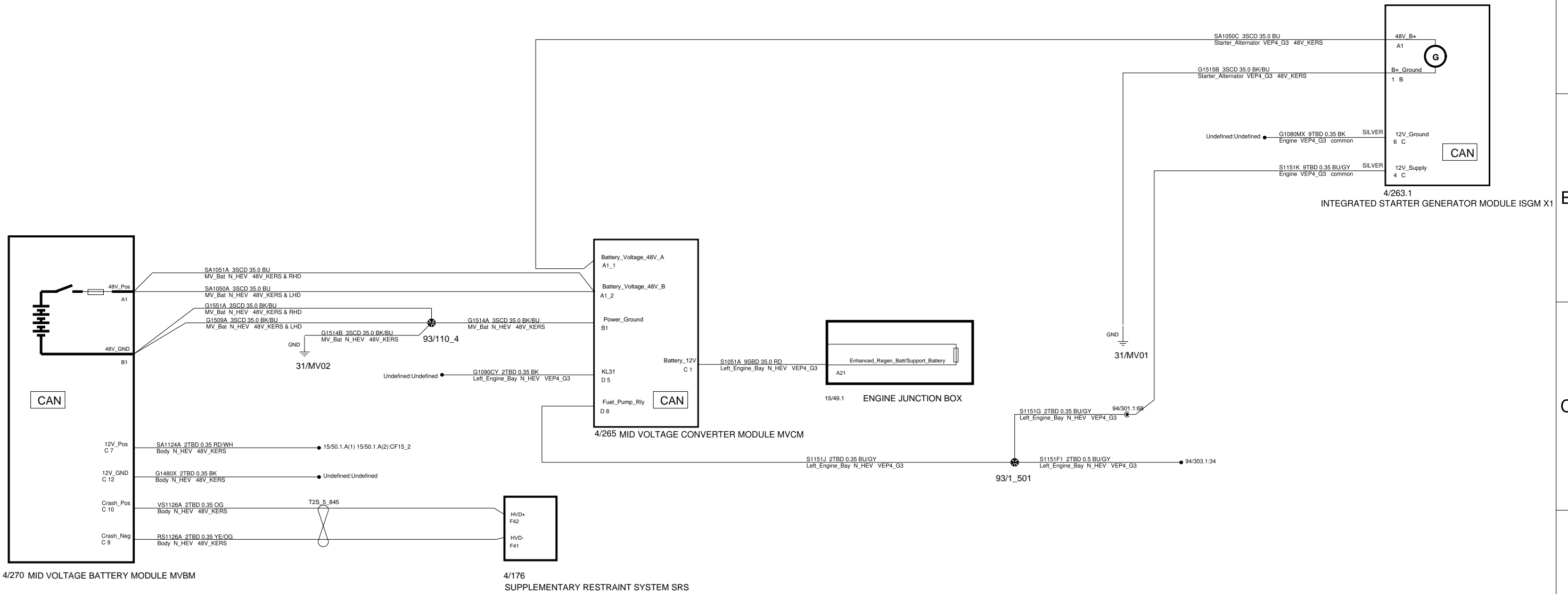

<p>The copying, distribution and utilization of this document as well as the communication of its contents to others without expressed authorization is prohibited. Offenders will be held liable for payment of damages. All rights reserved in the event of the grant of a patent, utility model or ornamental design registration.</p> <p><b>VOLVO</b> VOLVO CAR CORPORATION</p>	<b>Document title</b> CMA_622A_CC_All_5_30 1M_EI_Distribution_Mid_Voltage	
	<b>Document Type</b> DRAW/ELSY	<b>Release Status</b> RELEASED
	CEVT Document No 8888522365	<b>Edited</b> February/17/2022
	<b>Issue</b> 030	<b>Page No</b> 63/149



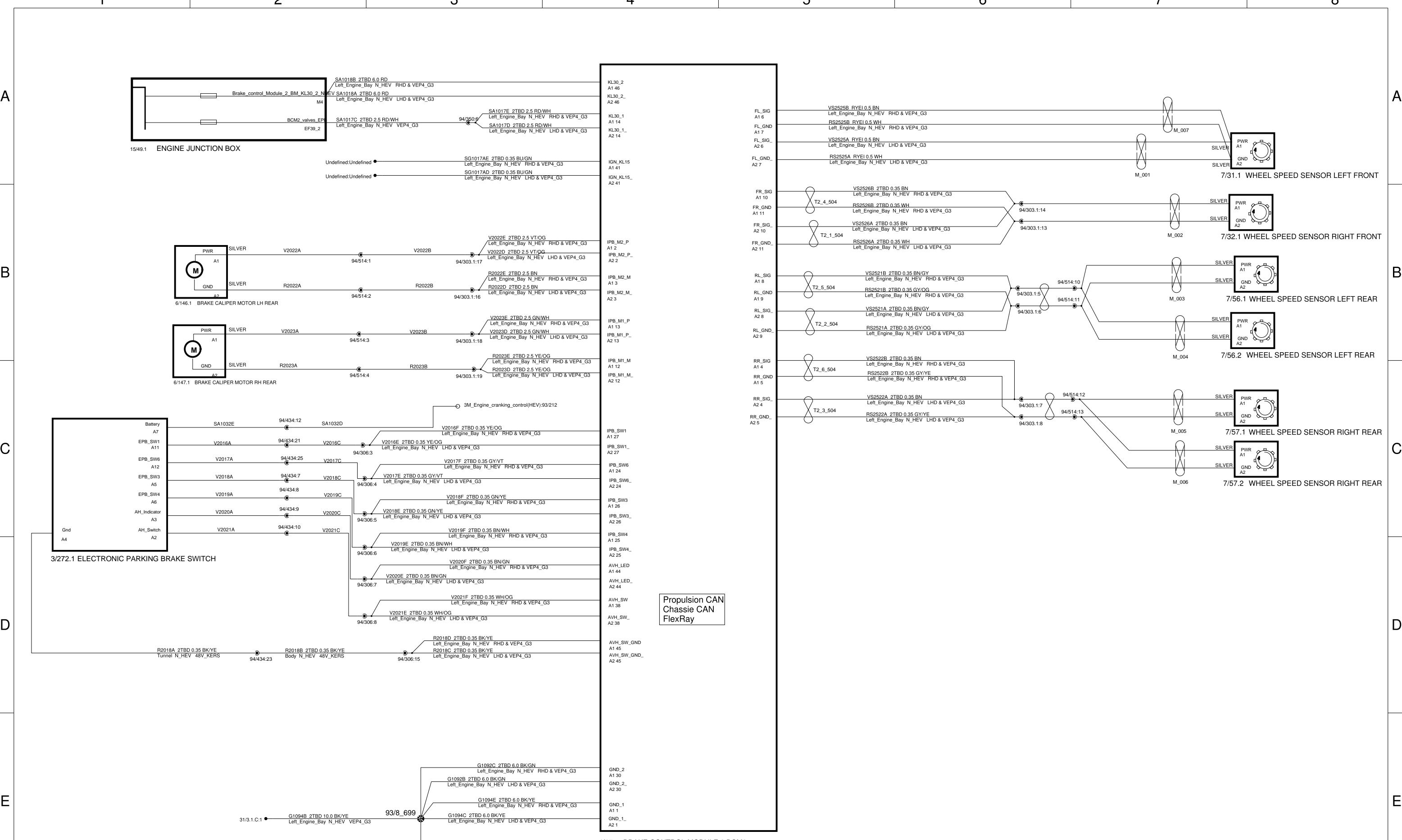

<p>The copying, distribution and utilization of this document as well as the communication of its contents to others without expressed authorization is prohibited. Offenders will be held liable for payment of damages. All rights reserved in the event of the grant of a patent, utility model or ornamental design registration.</p> <p><b>VOLVO</b> VOLVO CAR CORPORATION</p>		<b>Document title</b> CMA_622A_CC_All_5_30 2A_Braking_48V_KERS	
		<b>Document Type</b> DRAW/ELSY	<b>Release Status</b> RELEASED
		<b>CEVT Document No</b> 8888522365	<b>Edited</b> December/13/2021
		<b>Issue</b> 030	<b>Page No</b> 65/149

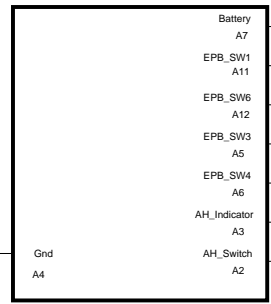
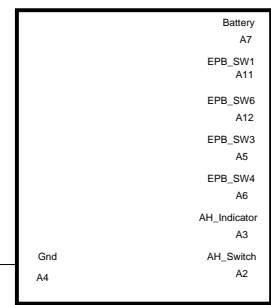
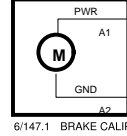
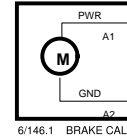
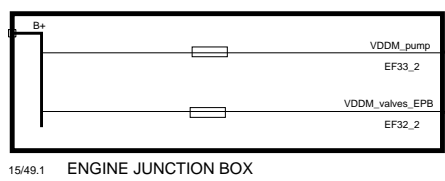
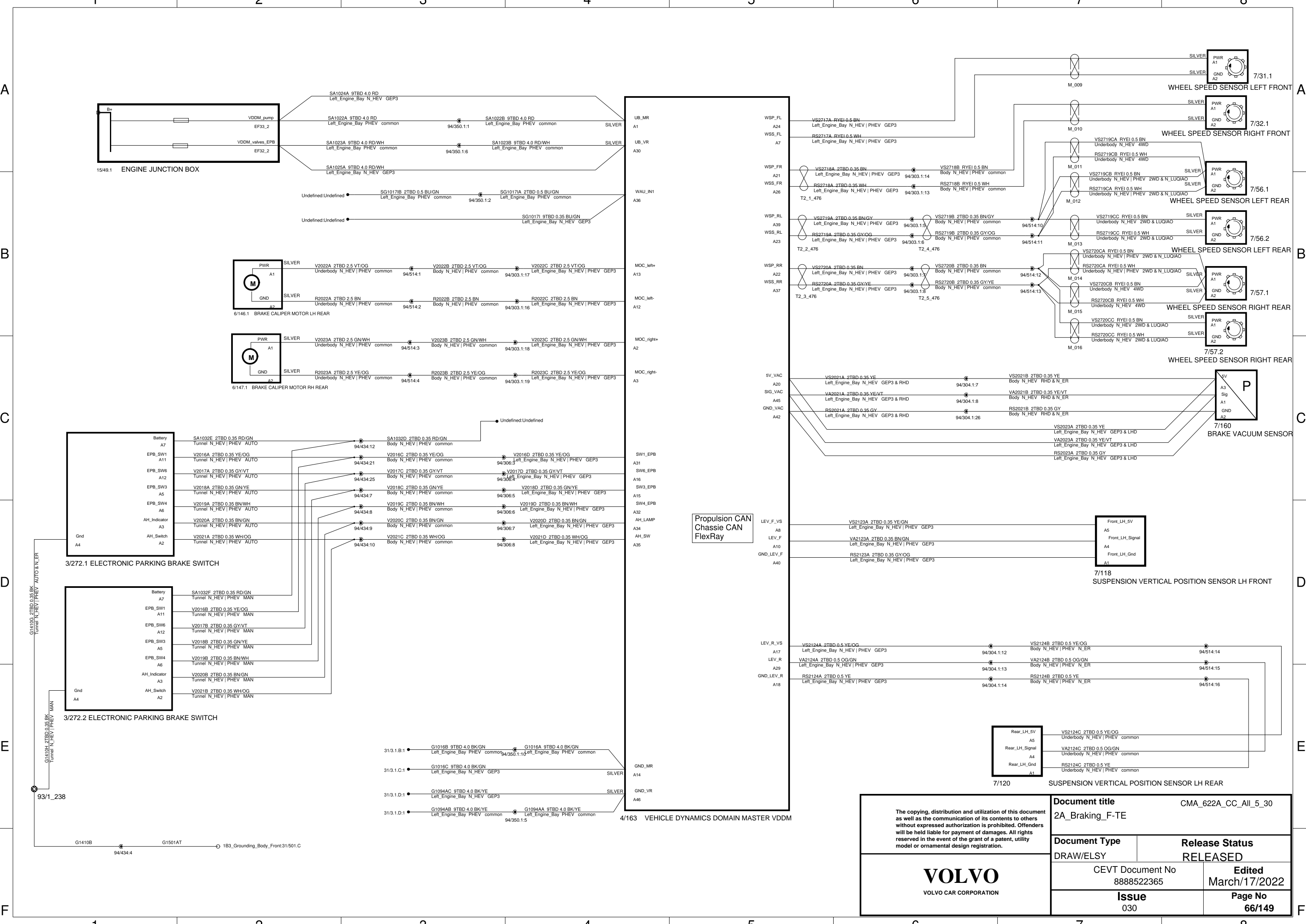

Propulsion CAN  
Chassis CAN  
FlexRay

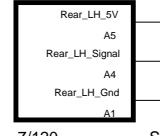
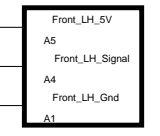

<p>The copying, distribution and utilization of this document as well as the communication of its contents to others without expressed authorization is prohibited. Offenders will be held liable for payment of damages. All rights reserved in the event of the grant of a patent, utility model or ornamental design registration.</p> <p><b>VOLVO</b> VOLVO CAR CORPORATION</p>		<p><b>Document title</b> CMA_622A_CC_All_5_30</p> <p><b>2A_Braking_F-TE</b></p>	
		<p><b>Document Type</b> DRAW/ELSY</p>	<p><b>Release Status</b> RELEASED</p>
		<p>CEVT Document No 8888522365</p>	<p><b>Edited</b> March/17/2022</p>
		<p><b>Issue</b> 030</p>	<p><b>Page No</b> 66/149</p>

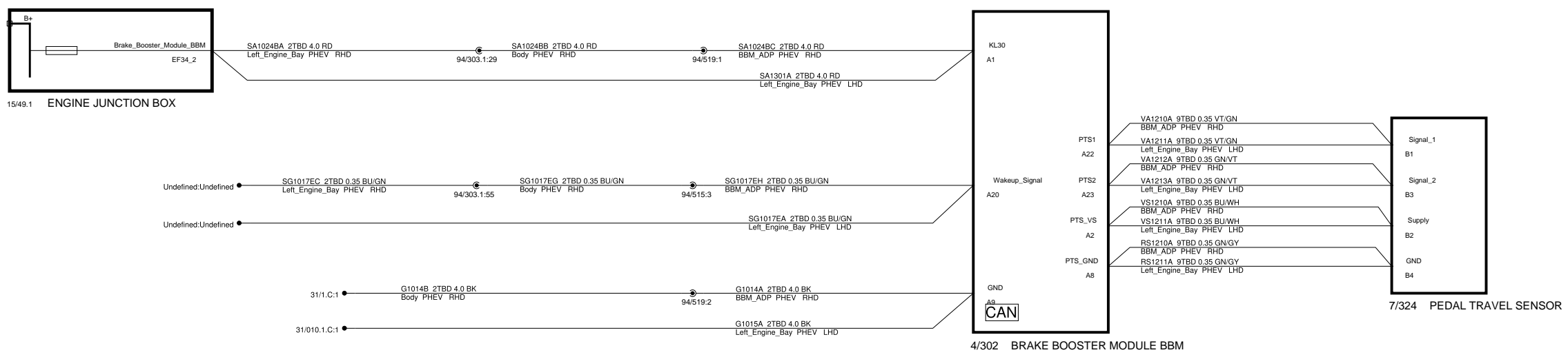

<p>The copying, distribution and utilization of this document as well as the communication of its contents to others without expressed authorization is prohibited. Offenders will be held liable for payment of damages. All rights reserved in the event of the grant of a patent, utility model or ornamental design registration.</p> <p><b>VOLVO</b> VOLVO CAR CORPORATION</p>	<b>Document title</b> CMA_622A_CC_All_5_30 2A_Braking_Hybrid	
	<b>Document Type</b> DRAW/ELSY	<b>Release Status</b> RELEASED
	CEVT Document No 8888522365	<b>Edited</b> March/17/2022
	<b>Issue</b> 030	<b>Page No</b> 67/149

# 2A Braking

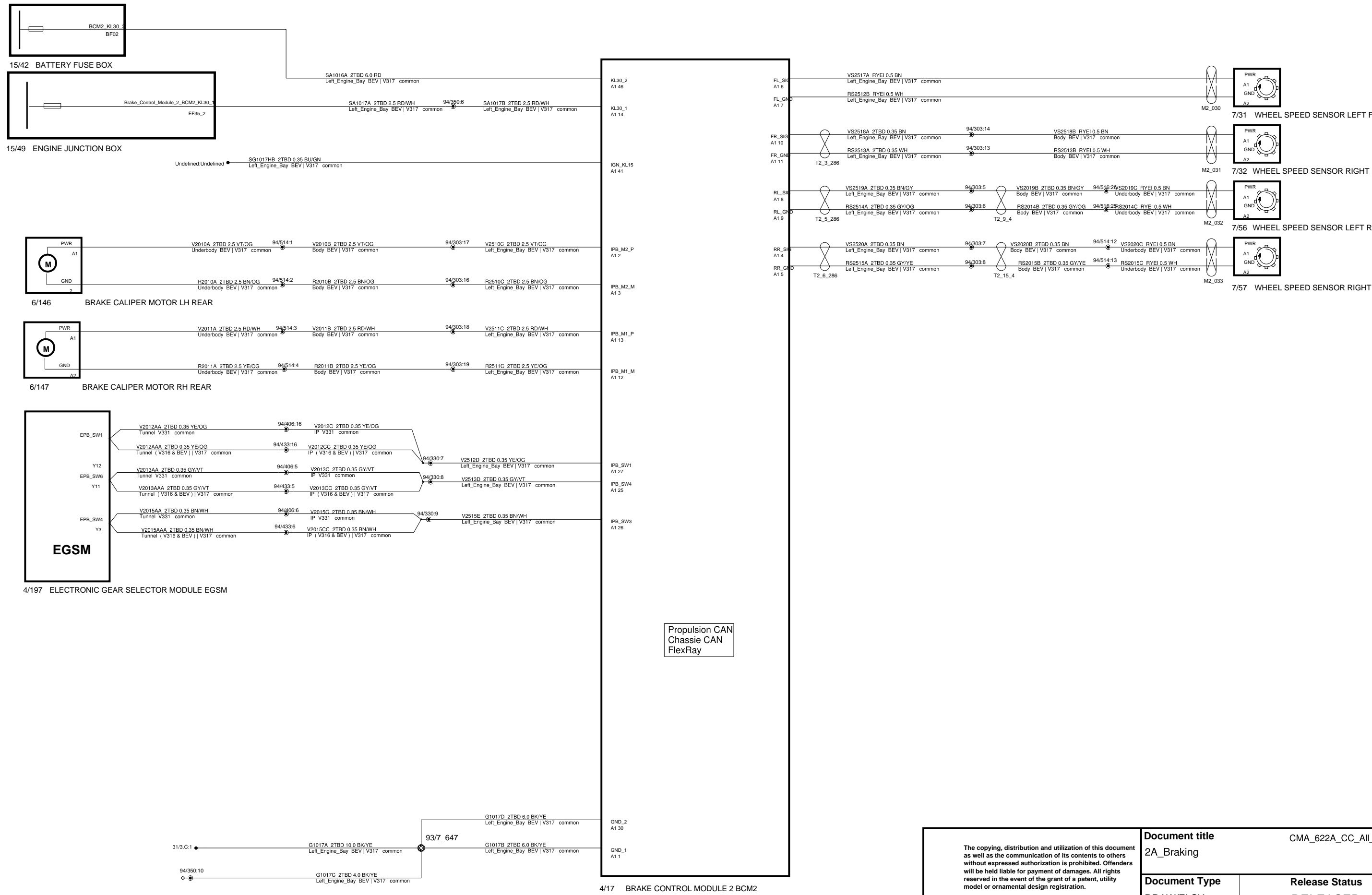

Propulsion CAN  
Chassie CAN  
FlexRay

<p>The copying, distribution and utilization of this document as well as the communication of its contents to others without expressed authorization is prohibited. Offenders will be held liable for payment of damages. All rights reserved in the event of the grant of a patent, utility model or ornamental design registration.</p> <p><b>VOLVO</b> VOLVO CAR CORPORATION</p>	<b>Document title</b> CMA_622A_CC_A11_5_30	
	<b>2A_Braking</b>	
	<b>Document Type</b> DRAW/ELSY	<b>Release Status</b> RELEASED
	Volvo Document No 33445458	<b>Edited</b> December/13/2021
<b>Issue</b> 030	<b>Page No</b> 64/149	

# 2E Power Steering

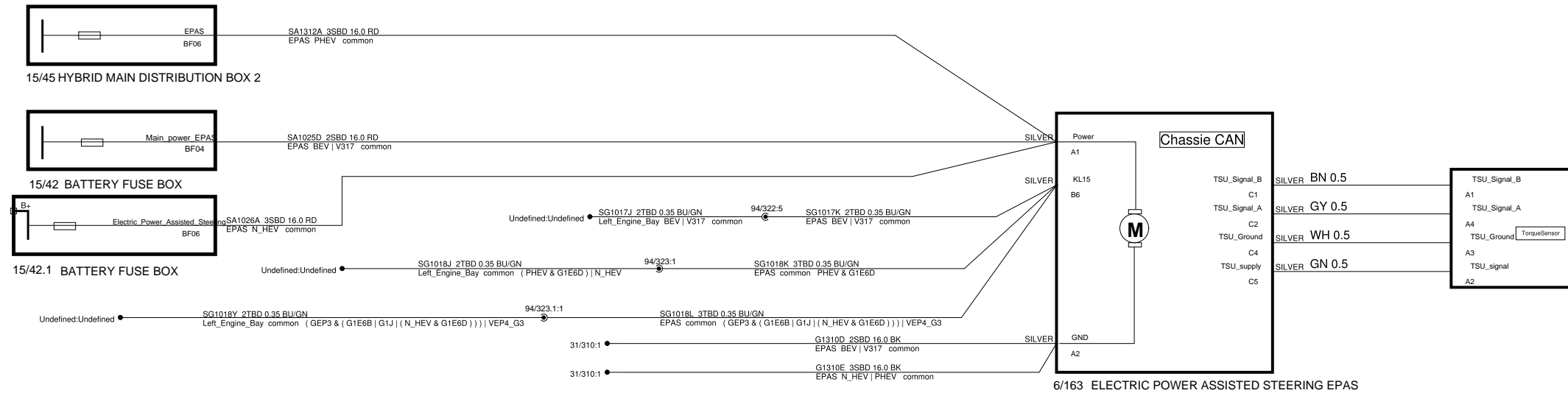

<p>The copying, distribution and utilization of this document as well as the communication of its contents to others without expressed authorization is prohibited. Offenders will be held liable for payment of damages. All rights reserved in the event of the grant of a patent, utility model or ornamental design registration.</p> <p><b>VOLVO</b> VOLVO CAR CORPORATION</p>	<b>Document title</b> CMA_622A_CC_All_5_30 2E_Power_Steering	
	<b>Document Type</b> DRAW/ELSY	<b>Release Status</b> RELEASED
	Volvo Document No 33445458	<b>Edited</b> May/22/2022
	<b>Issue</b> 030	<b>Page No</b> 69/149

# 2E2 Steering

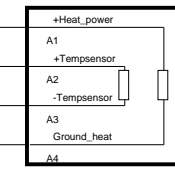
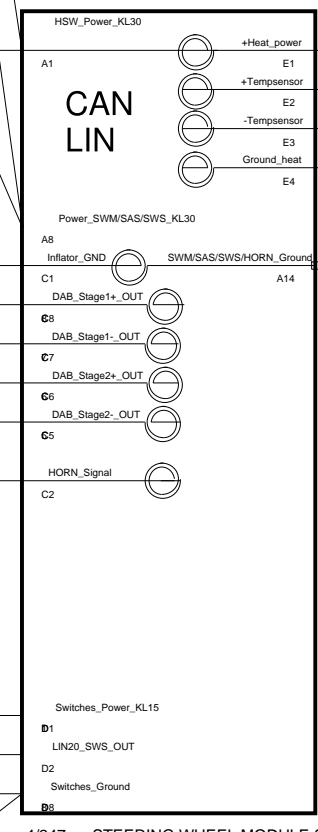
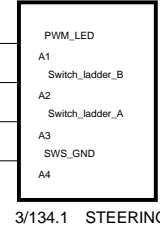
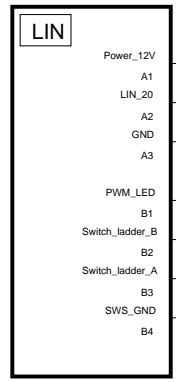
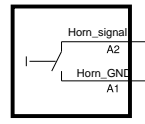
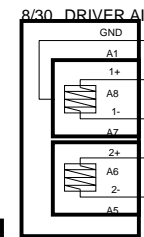
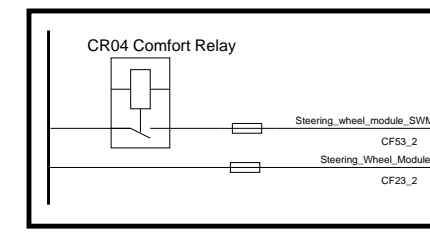
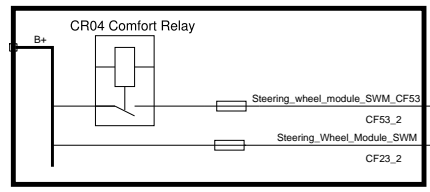

Wires found on 5G\_Steering\_Wheel\_Heating  
 SA1130A 2TBD 0.5 RD:WH Body N\_HEV|PHEV common 94/404.1:47 SA1130B 2TBD 0.5 RD:WH IP N\_HEV|PHEV common

Wires found on 5G\_Steering\_Wheel\_Heating  
 SA1129A 2TBD 0.5 RD:WH Body BEV common 94/404:48 SA1129B 2TBD 0.5 RD:WH IP BEV common

Wires found on 2P\_Supplementary\_Restraint\_System\_Igniters

Wires found on 8P\_Sound\_signaling

Wires found on 5G\_Steering\_Wheel\_Heating

<p>The copying, distribution and utilization of this document as well as the communication of its contents to others without expressed authorization is prohibited. Offenders will be held liable for payment of damages. All rights reserved in the event of the grant of a patent, utility model or ornamental design registration.</p> <p><b>VOLVO</b> VOLVO CAR CORPORATION</p>	<b>Document title</b> CMA_622A_CC_All_5_30 2E2_Steering	
	<b>Document Type</b> DRAW/ELSY	<b>Release Status</b> RELEASED
	Volvo Document No 33445458	<b>Edited</b> June/16/2021
	<b>Issue</b> 030	<b>Page No</b> 68/149

# 2G Levelling Control

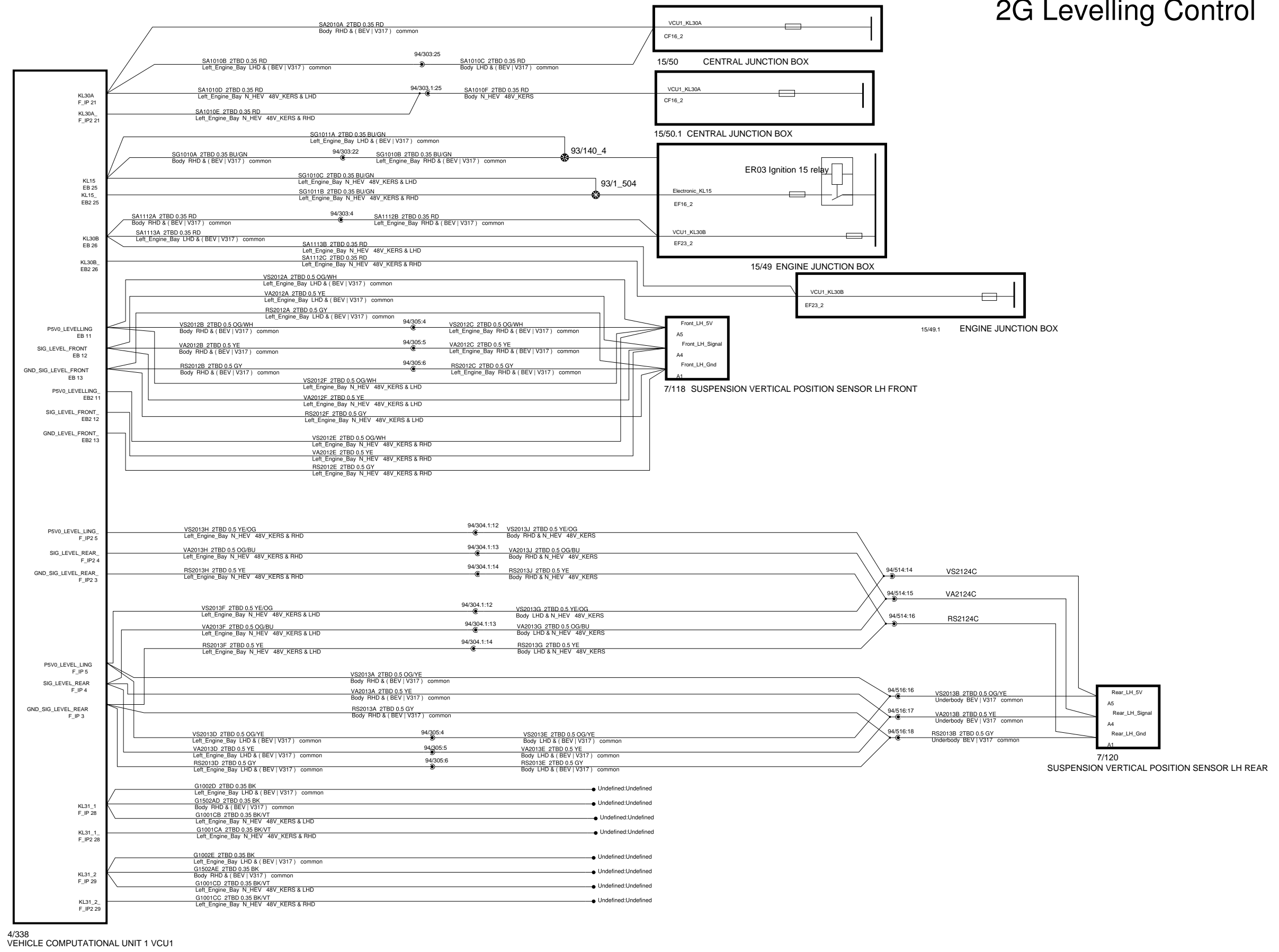

4/338  
VEHICLE COMPUTATIONAL UNIT 1 VCU1

<p>The copying, distribution and utilization of this document as well as the communication of its contents to others without expressed authorization is prohibited. Offenders will be held liable for payment of damages. All rights reserved in the event of the grant of a patent, utility model or ornamental design registration.</p> <p><b>VOLVO</b> VOLVO CAR CORPORATION</p>	<b>Document title</b> CMA_622A_CC_All_5_30	
	2G_Levelling_control	
	<b>Document Type</b> DRAW/ELSY	<b>Release Status</b> RELEASED
	Volvo Document No 33445458	<b>Edited</b> March/17/2022
<b>Issue</b> 030	<b>Page No</b> 70/149	

# 2M Pedestrian Protection

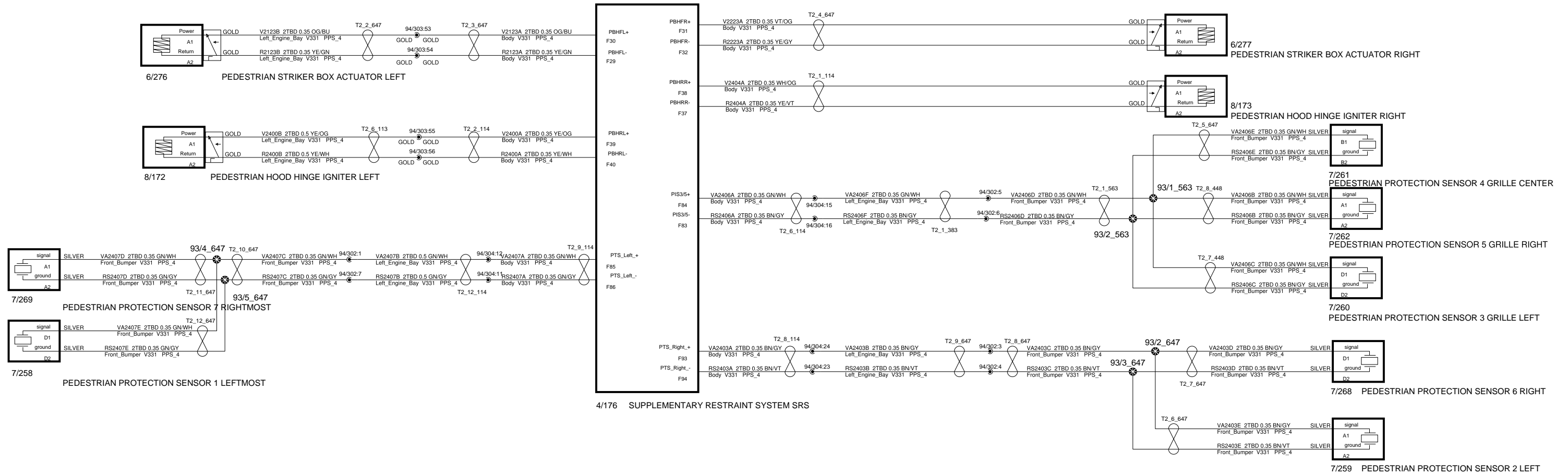

<p>The copying, distribution and utilization of this document as well as the communication of its contents to others without expressed authorization is prohibited. Offenders will be held liable for payment of damages. All rights reserved in the event of the grant of a patent, utility model or ornamental design registration.</p> <p><b>VOLVO</b> VOLVO CAR CORPORATION</p>	<b>Document title</b> CMA_622A_CC_All_5_30 2M_Pedestrian_Protection	
	<b>Document Type</b> DRAW/ELSY	<b>Release Status</b> RELEASED
	Volvo Document No 33445458	<b>Edited</b> February/17/2022
	<b>Issue</b> 030	<b>Page No</b> 71/149



# 2N Safety Belt Reminder

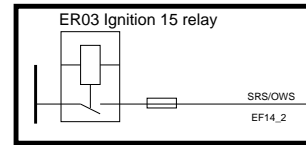

15/49 ENGINE JUNCTION BOX

Wires shown on page 10A Passenger Seat Internal Harness

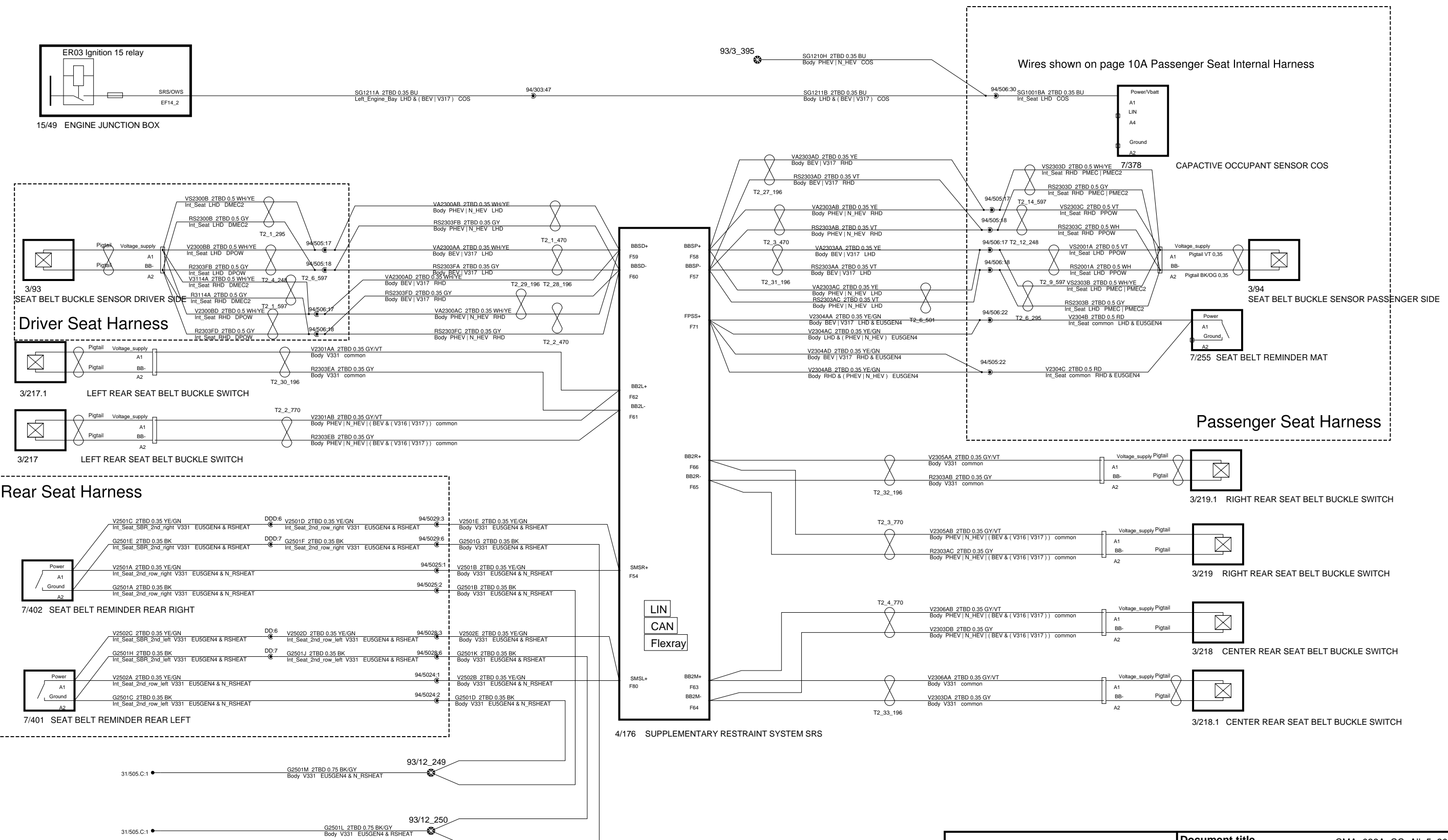

<p>The copying, distribution and utilization of this document as well as the communication of its contents to others without expressed authorization is prohibited. Offenders will be held liable for payment of damages. All rights reserved in the event of the grant of a patent, utility model or ornamental design registration.</p>		<p><b>Document title</b> CMA_622A_CC_All_5_30</p>	
		<p><b>Document Type</b> DRAW/ELSY</p>	
<p><b>VOLVO</b> VOLVO CAR CORPORATION</p>		<p><b>Release Status</b> RELEASED</p>	
		<p>Volvo Document No 33445458</p>	<p><b>Edited</b> March/17/2022</p>
		<p><b>Issue</b> 030</p>	<p><b>Page No</b> 72/149</p>

# 2O Collision Avoidance

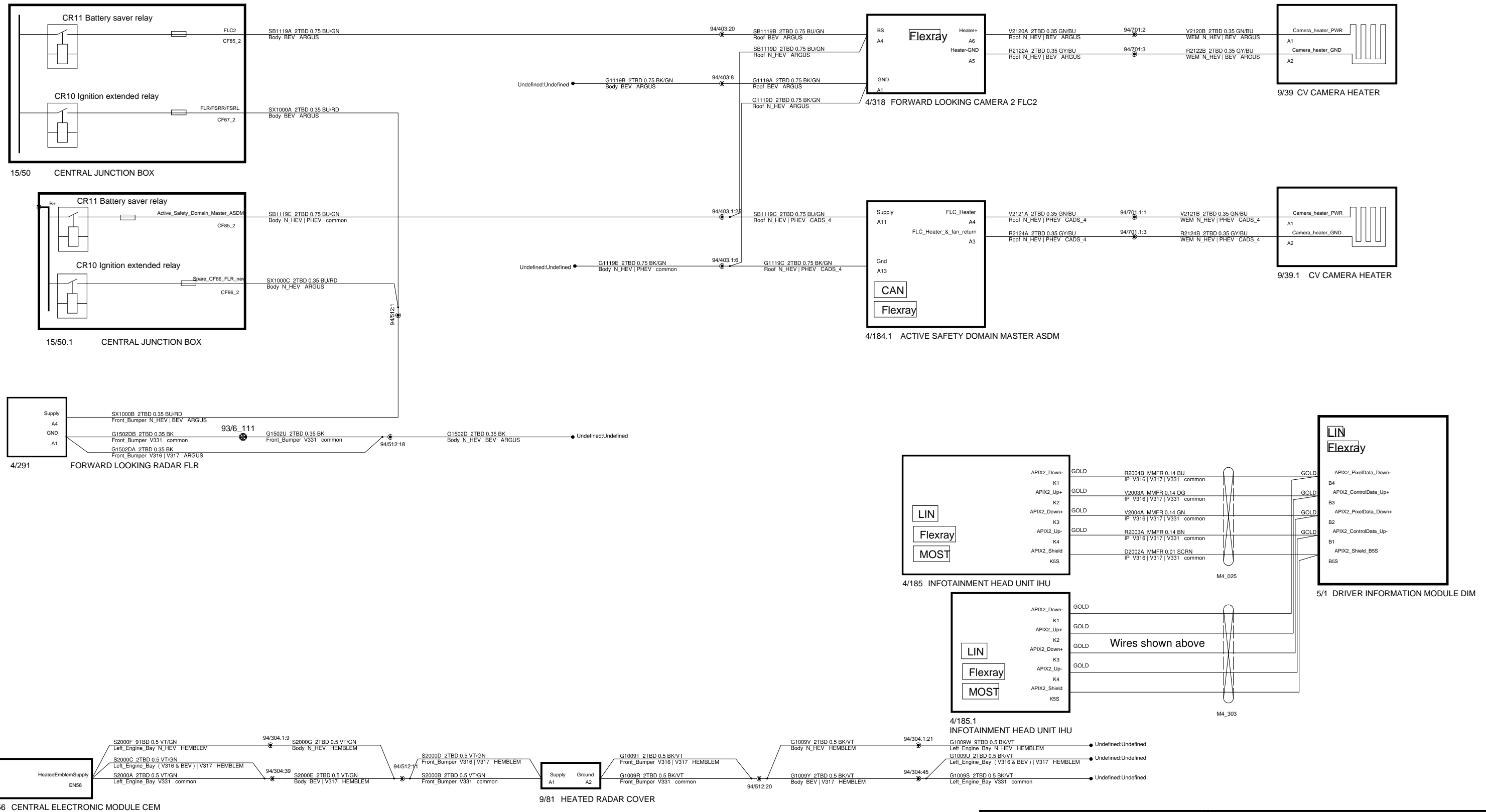

<p>The copying, distribution and utilization of this document as well as the communication of its contents to others without expressed authorization is prohibited. Offenders will be held liable for payment of damages. All rights reserved in the event of the grant of a patent, utility model or ornamental design registration.</p>		<b>Document title</b> CMA_622A_CC_All_5_30	
		2O_Collision_Avoidance	
<b>Document Type</b> DRAW/ELSY		<b>Release Status</b> RELEASED	
<p><b>VOLVO</b> VOLVO CAR CORPORATION</p>		Volvo Document No 33445458	<b>Edited</b> March/15/2022
		<b>Issue</b> 030	<b>Page No</b> 73/149

# 2P Supplementary Restraint System Igniters

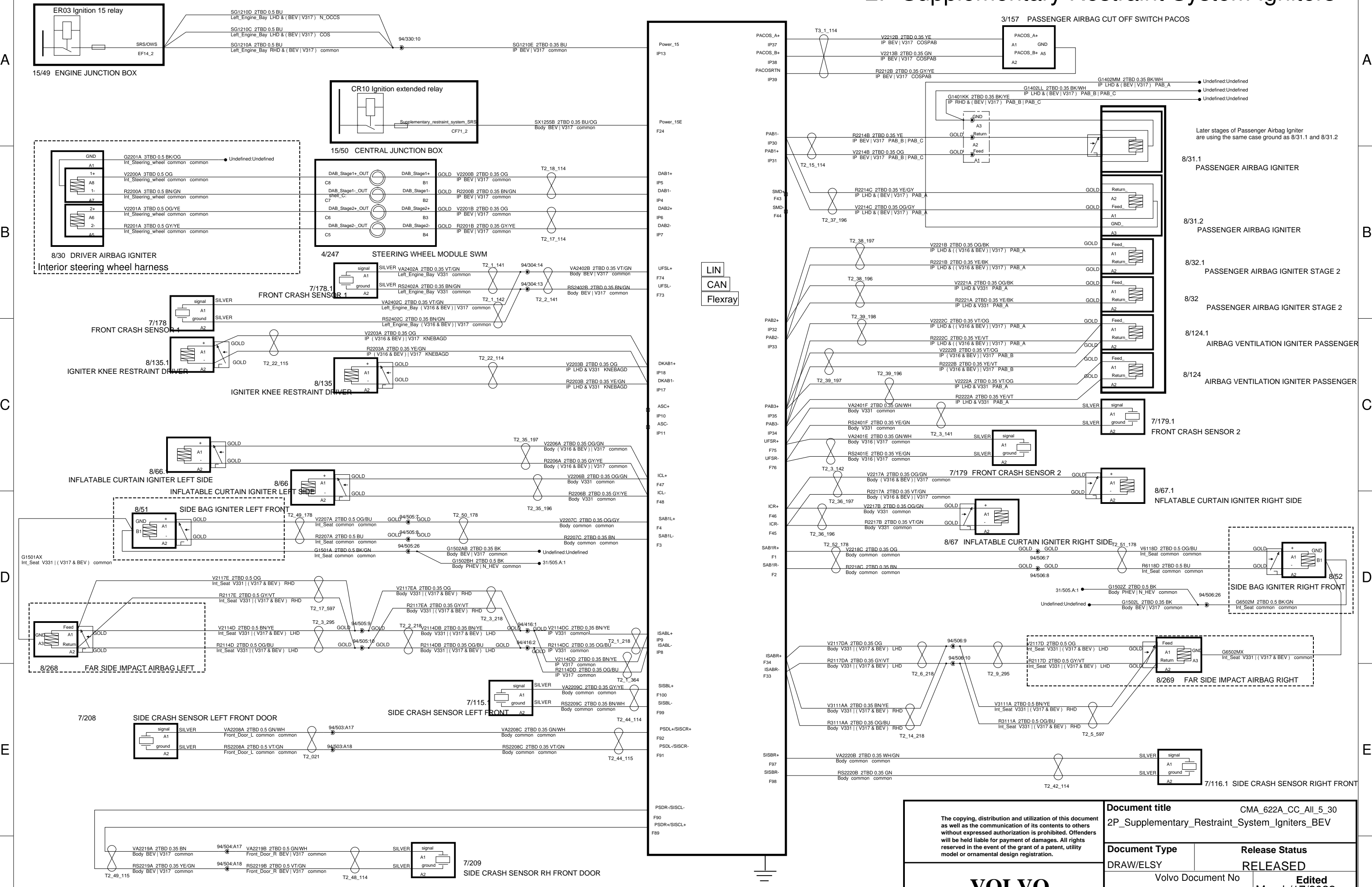

The copying, distribution and utilization of this document as well as the communication of its contents to others without expressed authorization is prohibited. Offenders will be held liable for payment of damages. All rights reserved in the event of the grant of a patent, utility model or ornamental design registration.

**VOLVO**  
VOLVO CAR CORPORATION

<b>Document title</b>		CMA_622A_CC_All_5_30 2P_Supplementary_Restraint_System_Igniters_BEV	
<b>Document Type</b>	<b>Release Status</b>		
DRAW/ELSY	RELEASED		
Volvo Document No 33445458		Edited March/17/2022	
<b>Issue</b>	<b>Page No</b>		
030	74/149		

# 2P Supplementary Restraint System Igniters HEV PHEV

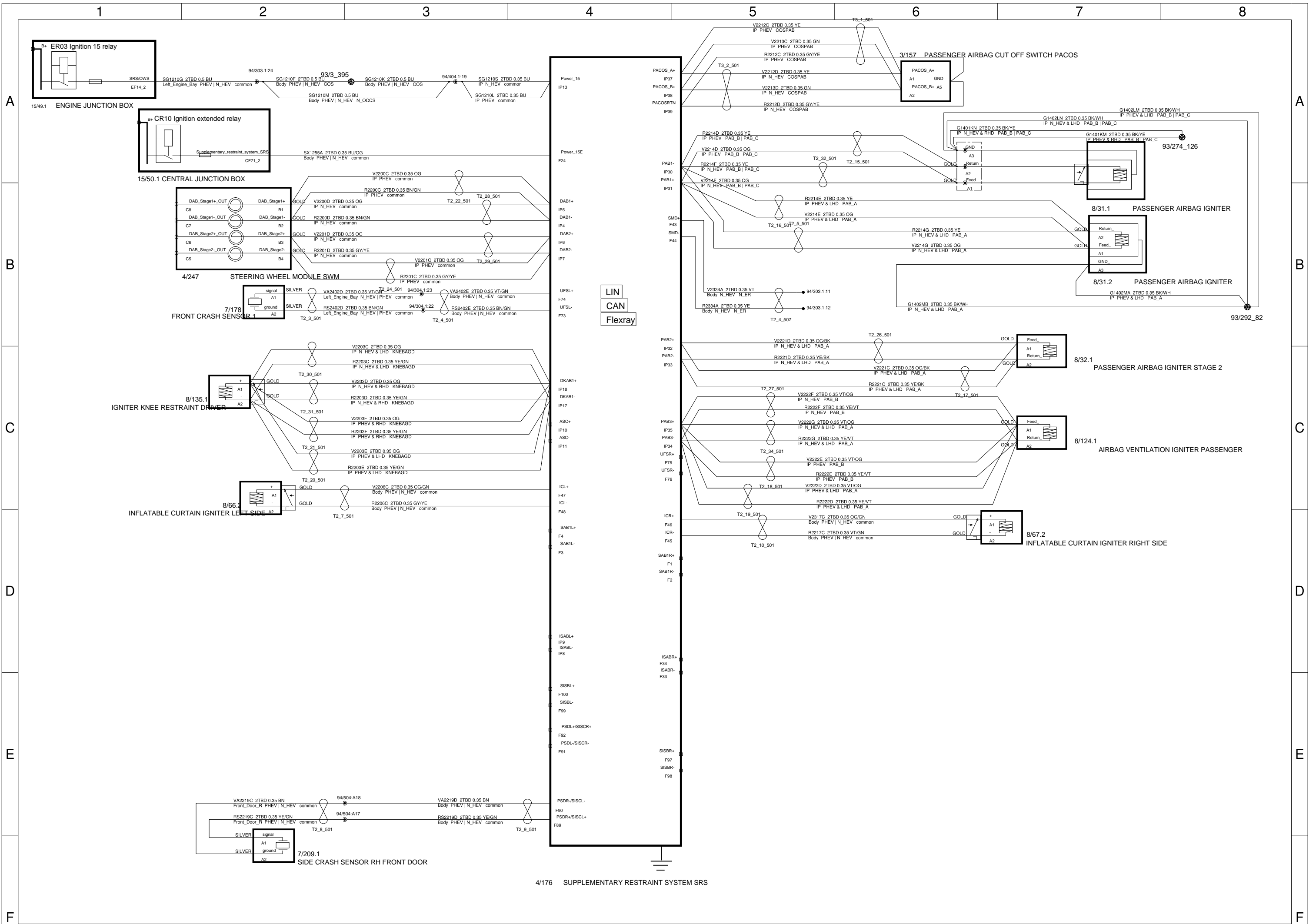

# 2R Safety Belt

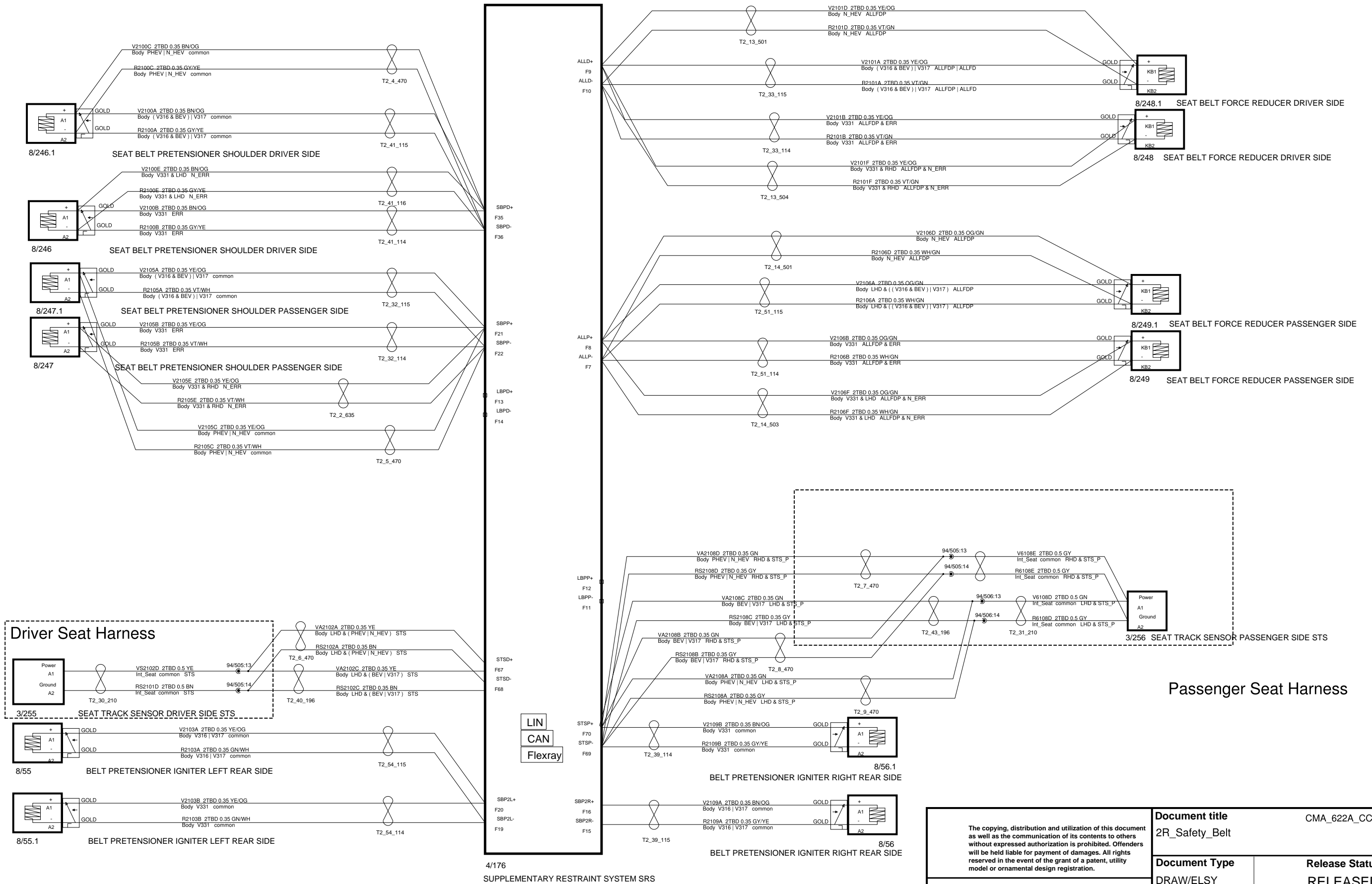

<p>The copying, distribution and utilization of this document as well as the communication of its contents to others without expressed authorization is prohibited. Offenders will be held liable for payment of damages. All rights reserved in the event of the grant of a patent, utility model or ornamental design registration.</p> <p><b>VOLVO</b> VOLVO CAR CORPORATION</p>		<b>Document title</b> CMA_622A_CC_All_5_30 2R_Safety_Belt	
		<b>Document Type</b> DRAW/ELSY	<b>Release Status</b> RELEASED
Volvo Document No 33445458		<b>Edited</b> May/22/2022	
<b>Issue</b> 030		<b>Page No</b> 76/149	

# 2S Restraint

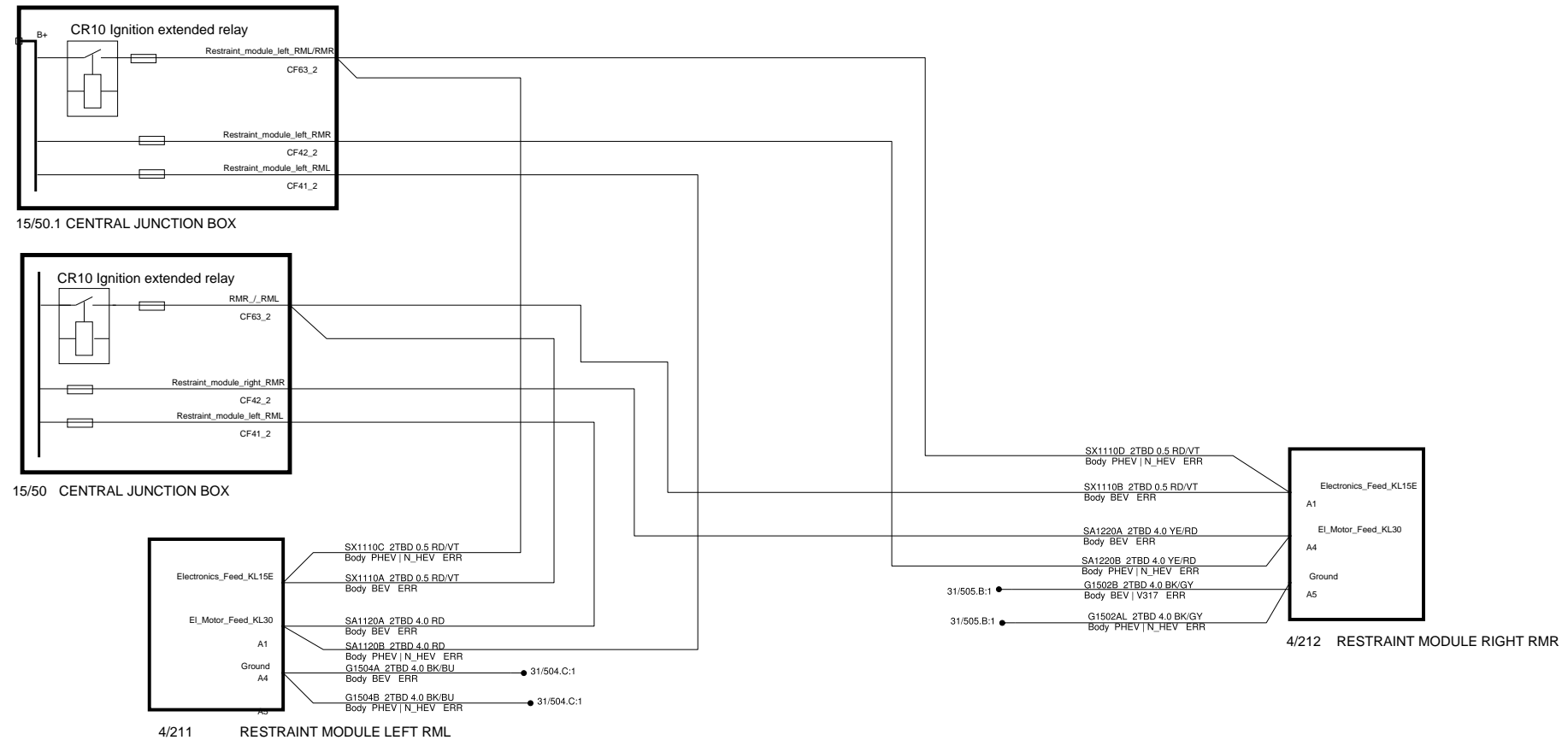

<p>The copying, distribution and utilization of this document as well as the communication of its contents to others without expressed authorization is prohibited. Offenders will be held liable for payment of damages. All rights reserved in the event of the grant of a patent, utility model or ornamental design registration.</p> <p><b>VOLVO</b> VOLVO CAR CORPORATION</p>	<b>Document title</b> CMA_622A_CC_All_5_30 2S_Restraint	
	<b>Document Type</b> DRAW/ELSY	<b>Release Status</b> RELEASED
	Volvo Document No 33445458	<b>Edited</b> June/16/2021
	<b>Issue</b> 030	<b>Page No</b> 77/149

# 3A, 3C Engine Management

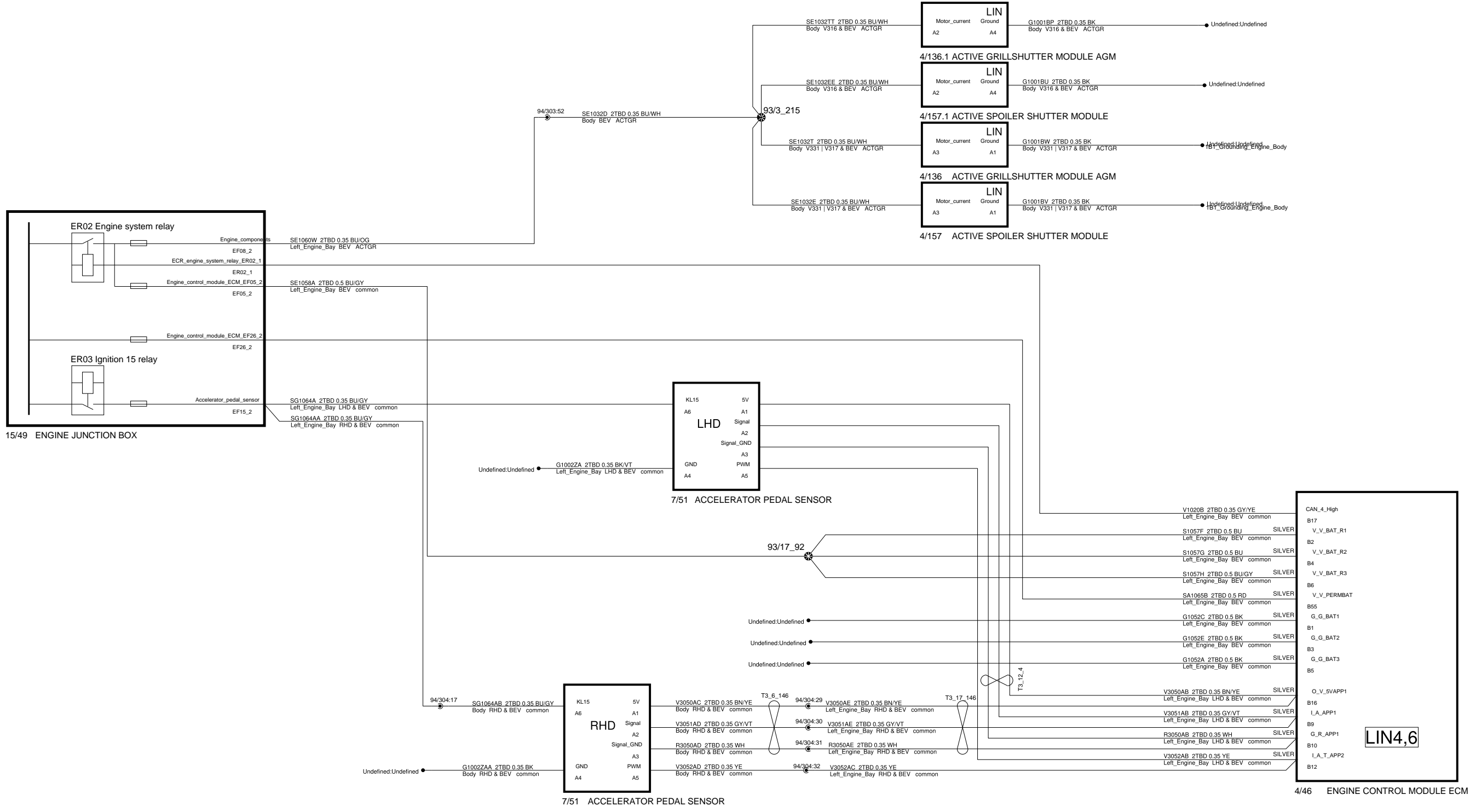

<p>The copying, distribution and utilization of this document as well as the communication of its contents to others without expressed authorization is prohibited. Offenders will be held liable for payment of damages. All rights reserved in the event of the grant of a patent, utility model or ornamental design registration.</p> <p><b>VOLVO</b> VOLVO CAR CORPORATION</p>		<p><b>Document title</b> CMA_622A_CC_All_5_30 3A_3C_Engine_management</p>	
		<p><b>Document Type</b> DRAW/ELSY</p>	<p><b>Release Status</b> RELEASED</p>
		<p>Volvo Document No 33445458</p>	<p><b>Edited</b> June/16/2021</p>
		<p><b>Issue</b> 030</p>	<p><b>Page No</b> 78/149</p>

# 3A, 3D Engine Management (HEV)

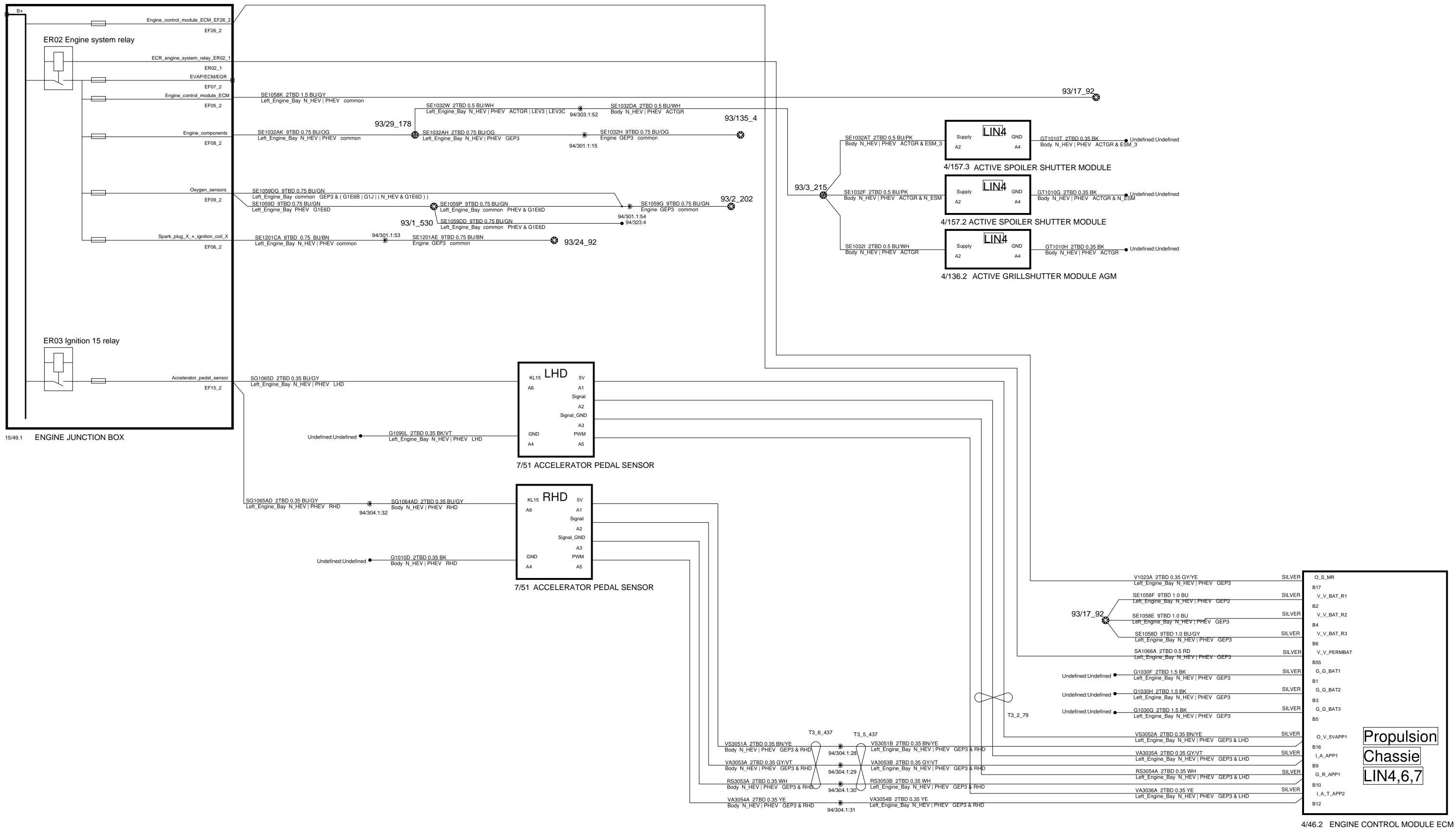

<p>The copying, distribution and utilization of this document as well as the communication of its contents to others without expressed authorization is prohibited. Offenders will be held liable for payment of damages. All rights reserved in the event of the grant of a patent, utility model or ornamental design registration.</p> <p><b>VOLVO</b> VOLVO CAR CORPORATION</p>	<b>Document title</b> CMA_622A_CC_All_5_30 3A_3D_Engine_Management_(HEV)	
	<b>Document Type</b> DRAW/ELSY	<b>Release Status</b> RELEASED
	CEVT Document No 8888522365	<b>Edited</b> March/17/2022
	<b>Issue</b> 030	<b>Page No</b> 79/149



# 3A, 3D Engine Management VEP4 GEN3 (HEV)

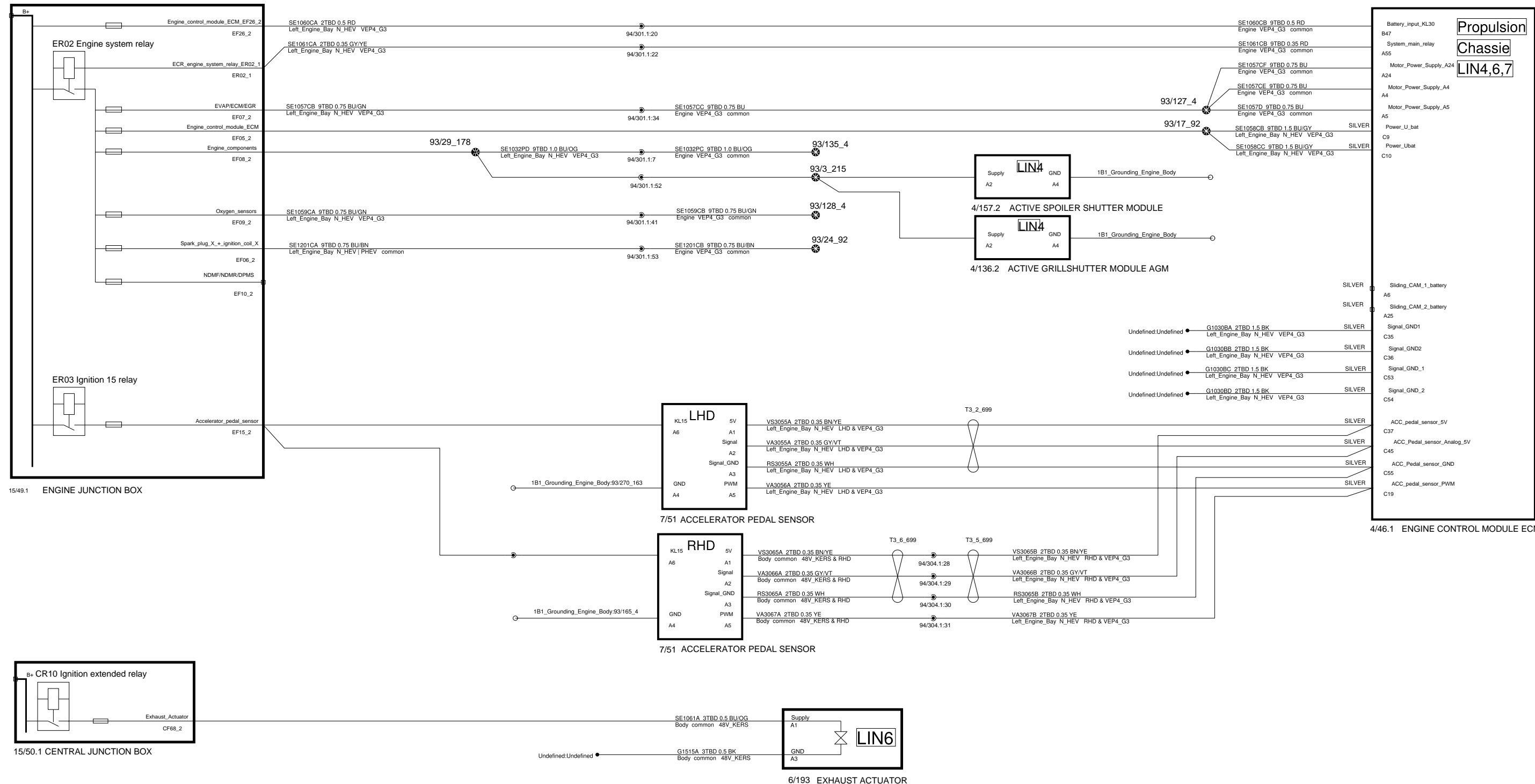

<p>The copying, distribution and utilization of this document as well as the communication of its contents to others without expressed authorization is prohibited. Offenders will be held liable for payment of damages. All rights reserved in the event of the grant of a patent, utility model or ornamental design registration.</p> <p><b>VOLVO</b> VOLVO CAR CORPORATION</p>	<b>Document title</b> CMA_622A_CC_All_5_30 3A_3D_Engine_Management_VEP4_GEN3_(HEV)	
	<b>Document Type</b> DRAW/ELSY	<b>Release Status</b> RELEASED
	CEVT Document No 8888522365	<b>Edited</b> March/01/2022
	<b>Issue</b> 030	<b>Page No</b> 80/149

# 3A Engine Management GEP3 (HEV)

Propulsion  
Chassis  
LIN4,6,7

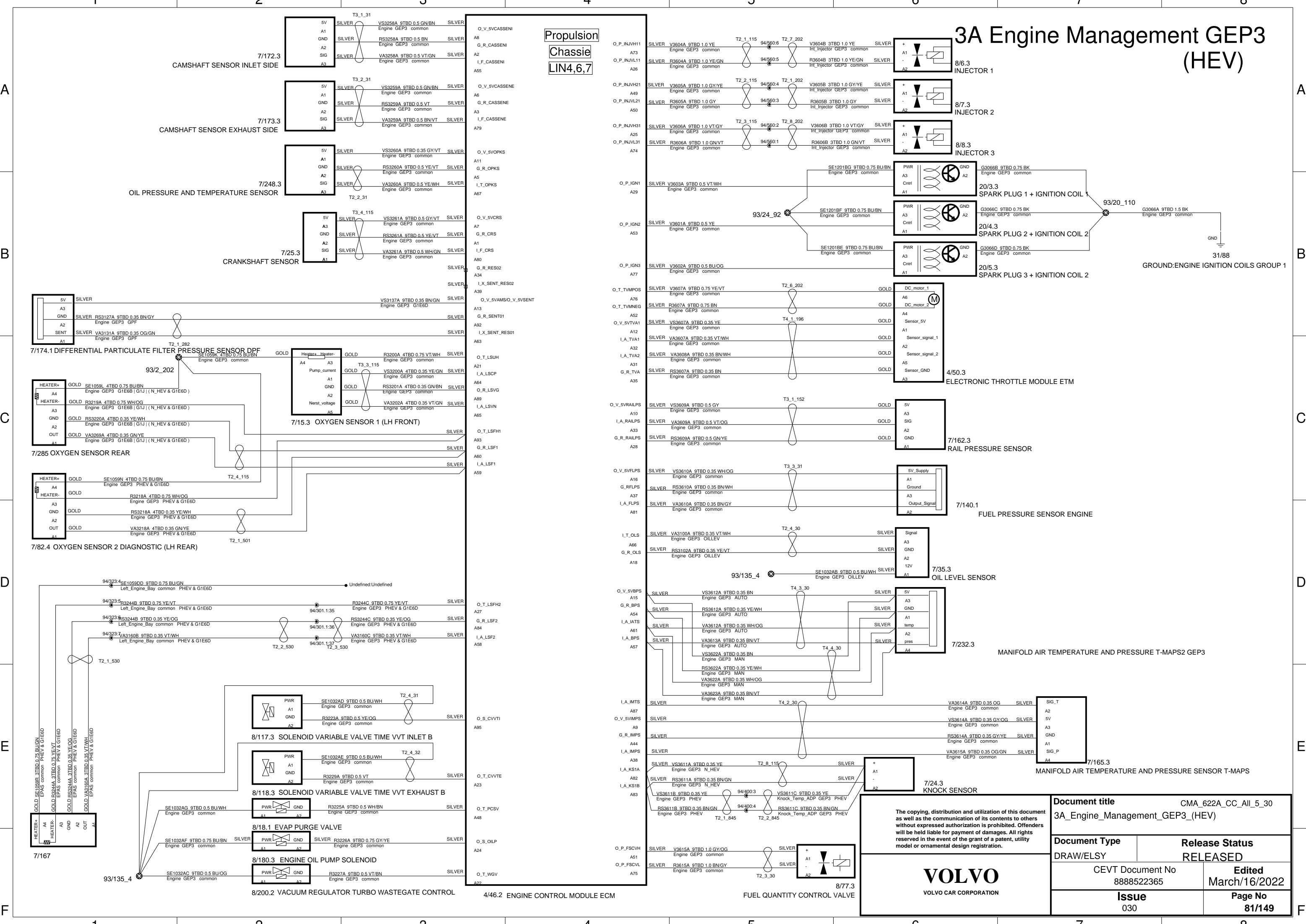

The copying, distribution and utilization of this document as well as the communication of its contents to others without expressed authorization is prohibited. Offenders will be held liable for payment of damages. All rights reserved in the event of the grant of a patent, utility model or ornamental design registration.

**VOLVO**  
VOLVO CAR CORPORATION

<b>Document title</b> CMA_622A_CC_All_5_30 3A_Engine_Management_GEP3_(HEV)	
<b>Document Type</b> DRAW/ELSY	<b>Release Status</b> RELEASED
CEVT Document No 8888522365	<b>Edited</b> March/16/2022
<b>Issue</b> 030	<b>Page No</b> 81/149

# 3A Engine Management VEP4\_G3 (HEV)

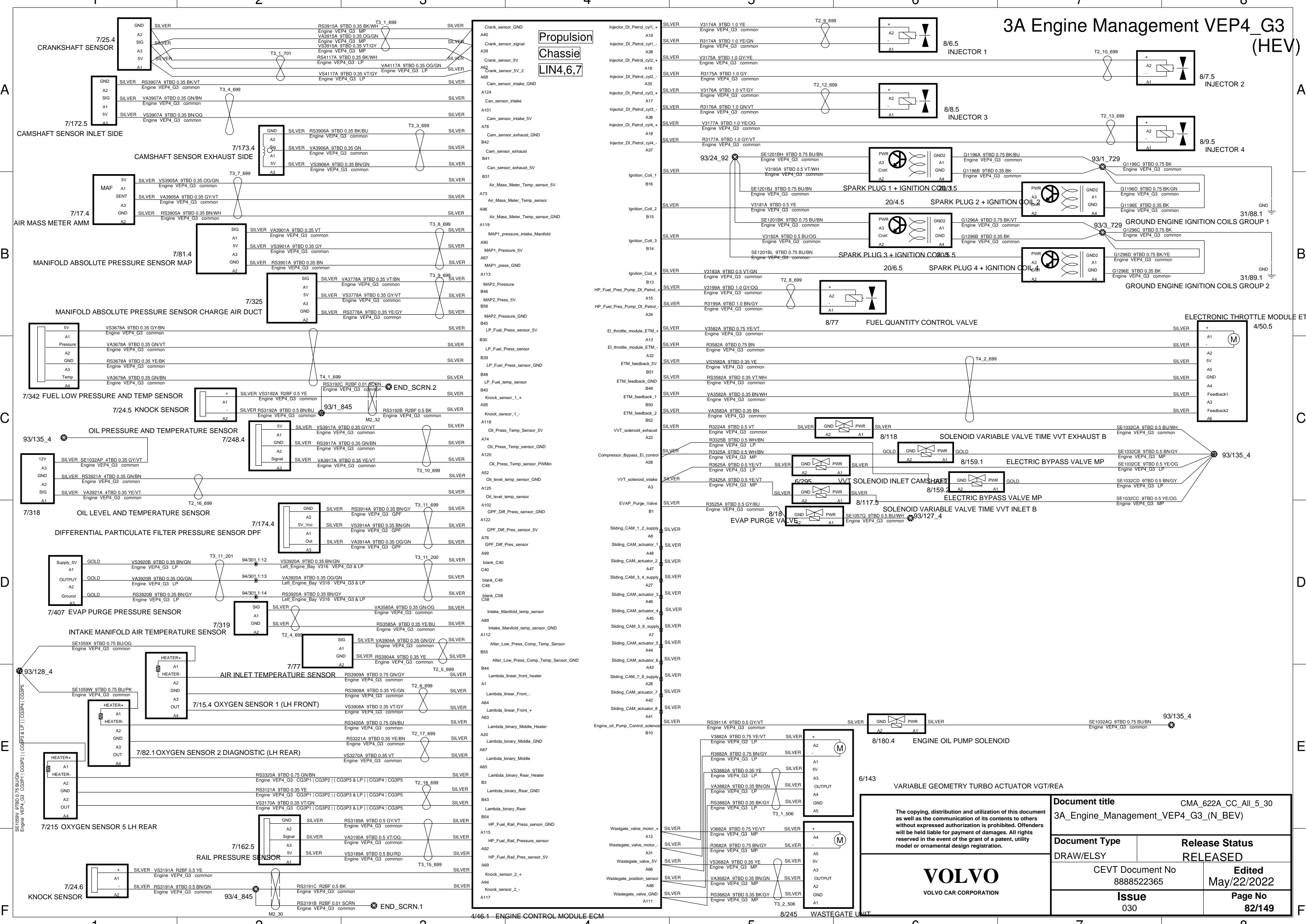

The copying, distribution and utilization of this document as well as the communication of its contents to others without expressed authorization is prohibited. Offenders will be held liable for payment of damages. All rights reserved in the event of the grant of a patent, utility model or ornamental design registration.

**VOLVO**  
VOLVO CAR CORPORATION

<b>Document title</b> CMA_622A_CC_All_5_30 3A_Engine_Management_VEP4_G3_(N_BEV)	
<b>Document Type</b> DRAW/ELSY	<b>Release Status</b> RELEASED
CEVT Document No 8888522365	<b>Edited</b> May/22/2022
<b>Issue</b> 030	<b>Page No</b> 82/149

# 3B Management BEV Driveline

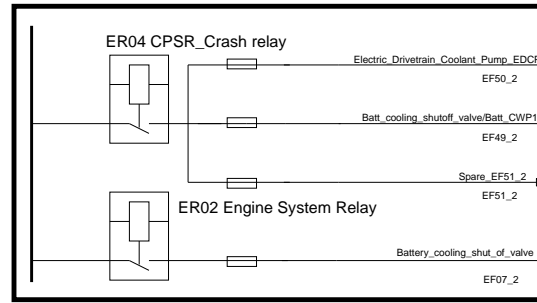

15/49 ENGINE JUNCTION BOX

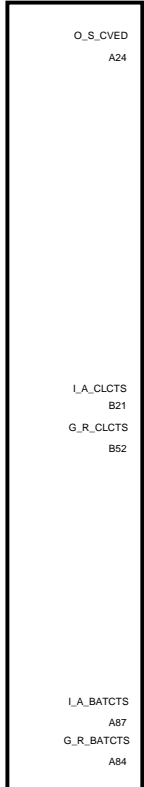
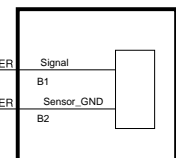
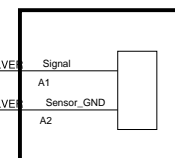
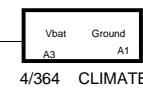
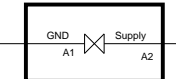
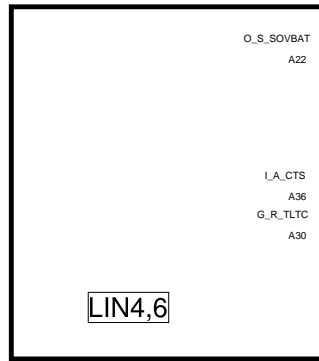
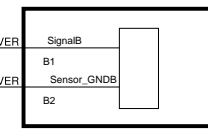
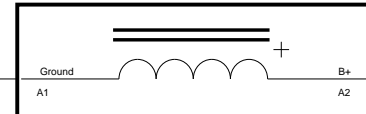
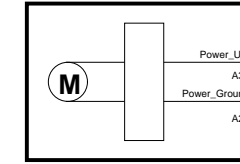
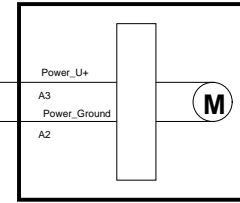

<b>VOLVO</b> VOLVO CAR CORPORATION	<b>Document title</b> CMA_622A_CC_All_5_30 3B_Management_BEV_Driveline	
	<b>Document Type</b> DRAW/ELSY	<b>Release Status</b> RELEASED
	Volvo Document No 33445458	<b>Edited</b> August/30/2021
	<b>Issue</b> 030	<b>Page No</b> 83/149

# 3B Management Hybrid Driveline (PHEV)

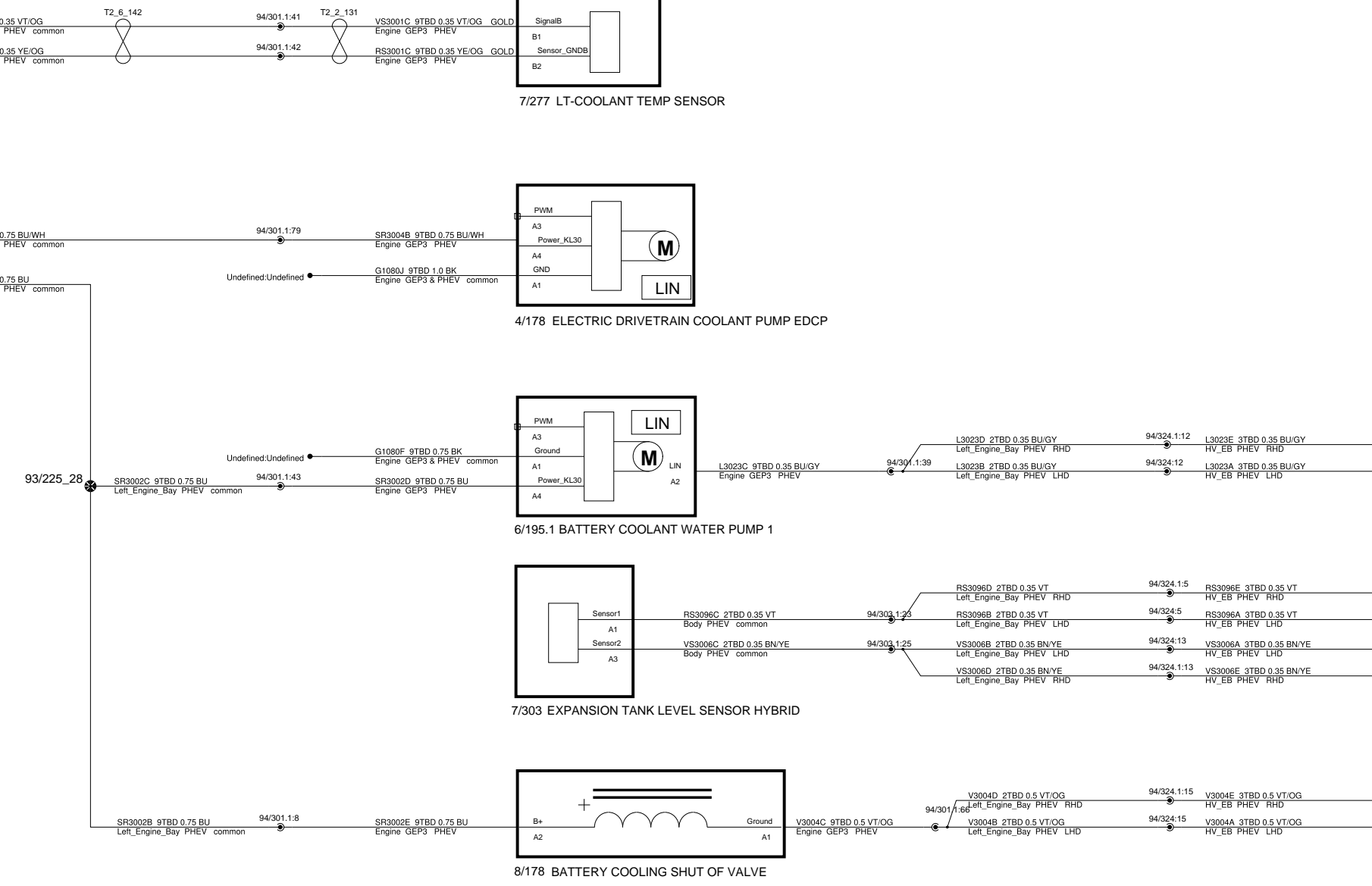
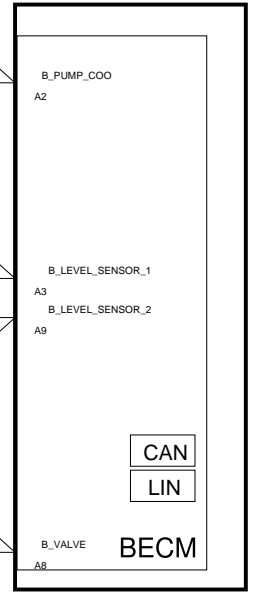
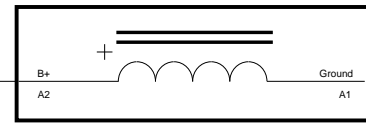
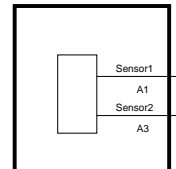
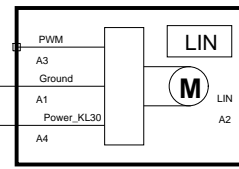
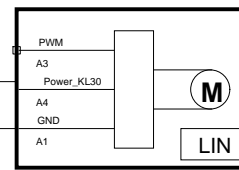
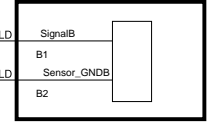
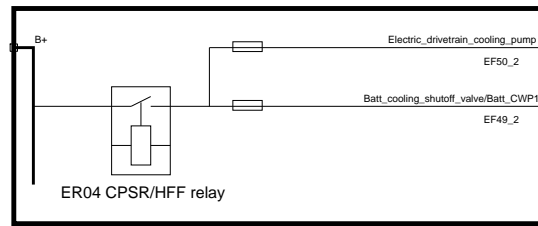
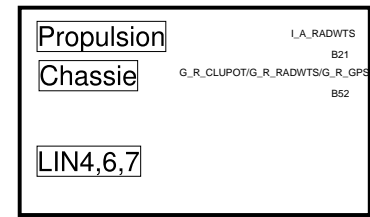

The copying, distribution and utilization of this document as well as the communication of its contents to others without expressed authorization is prohibited. Offenders will be held liable for payment of damages. All rights reserved in the event of the grant of a patent, utility model or ornamental design registration.	<b>Document title</b> CMA_622A_CC_All_5_30 3B_Management_Hybrid_Driveline_HEV	
	<b>Document Type</b> DRAW/ELSY	<b>Release Status</b> RELEASED
	CEVT Document No 8888522365	<b>Edited</b> March/17/2022
	<b>Issue</b> 030	<b>Page No</b> 84/149
<b>VOLVO</b> VOLVO CAR CORPORATION		

# 3D Engine Thermal Management

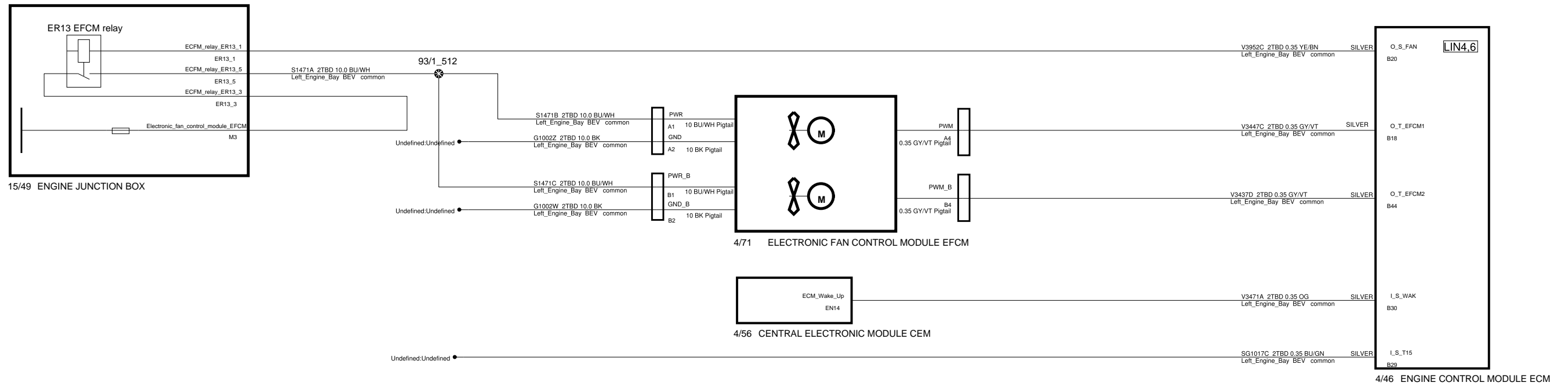

<p>The copying, distribution and utilization of this document as well as the communication of its contents to others without expressed authorization is prohibited. Offenders will be held liable for payment of damages. All rights reserved in the event of the grant of a patent, utility model or ornamental design registration.</p> <p><b>VOLVO</b> VOLVO CAR CORPORATION</p>	<b>Document title</b> CMA_622A_CC_All_5_30 3D_Engine_thermal_management_BEV	
	<b>Document Type</b> DRAW/ELSY	<b>Release Status</b> RELEASED
	Volvo Document No 33445458	<b>Edited</b> June/16/2021
	<b>Issue</b> 030	<b>Page No</b> 85/149

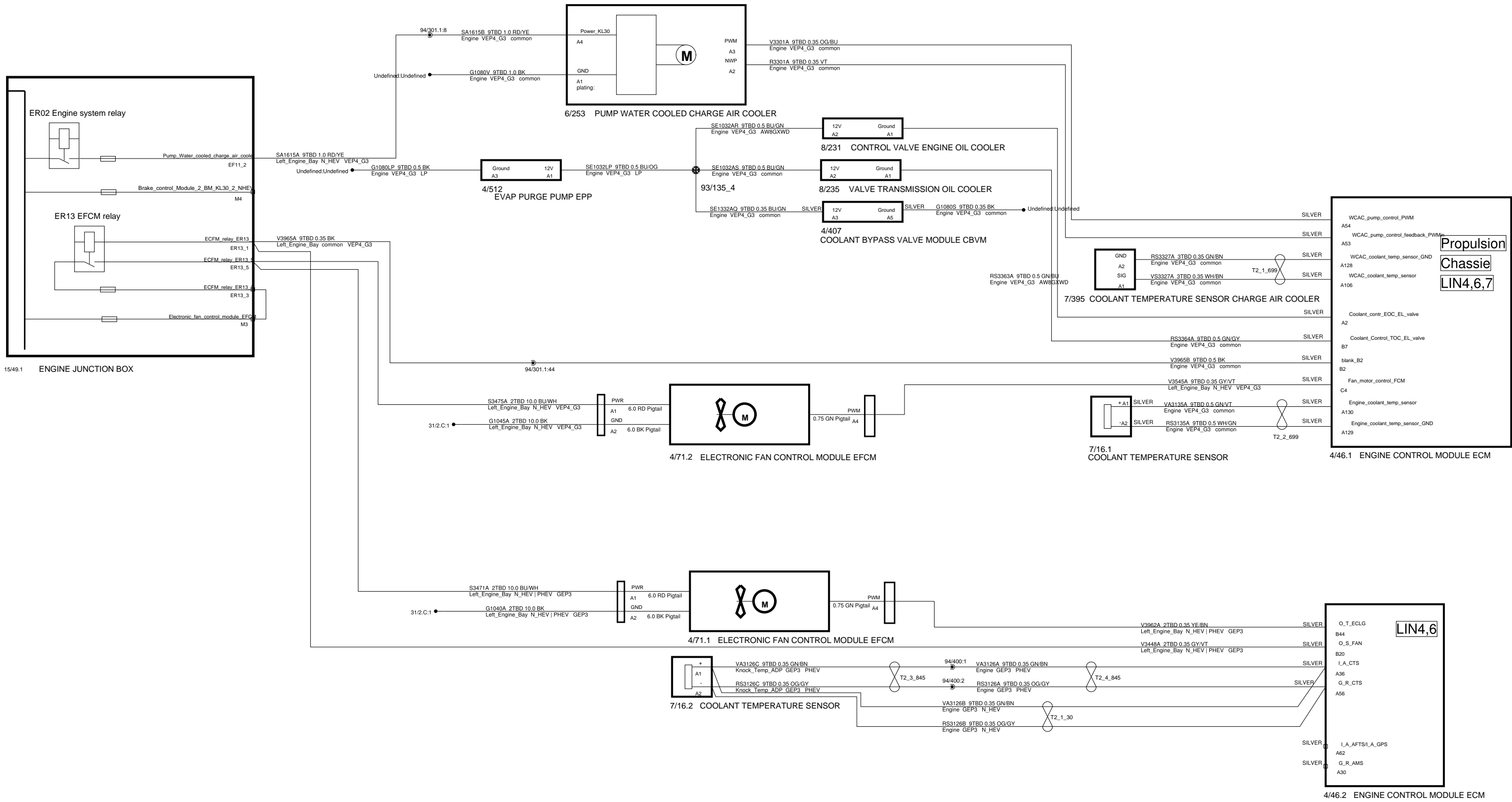

<p>The copying, distribution and utilization of this document as well as the communication of its contents to others without expressed authorization is prohibited. Offenders will be held liable for payment of damages. All rights reserved in the event of the grant of a patent, utility model or ornamental design registration.</p> <p><b>VOLVO</b> VOLVO CAR CORPORATION</p>	<b>Document title</b> CMA_622A_CC_A11_5_30 3D_Engine_thermal_management_HEV	
	<b>Document Type</b> DRAW/ELSY	<b>Release Status</b> RELEASED
	CEVT Document No 8888522365	<b>Edited</b> May/22/2022
	<b>Issue</b> 030	<b>Page No</b> 86/149

# 3E Automatic Gear Shifting 7DCT

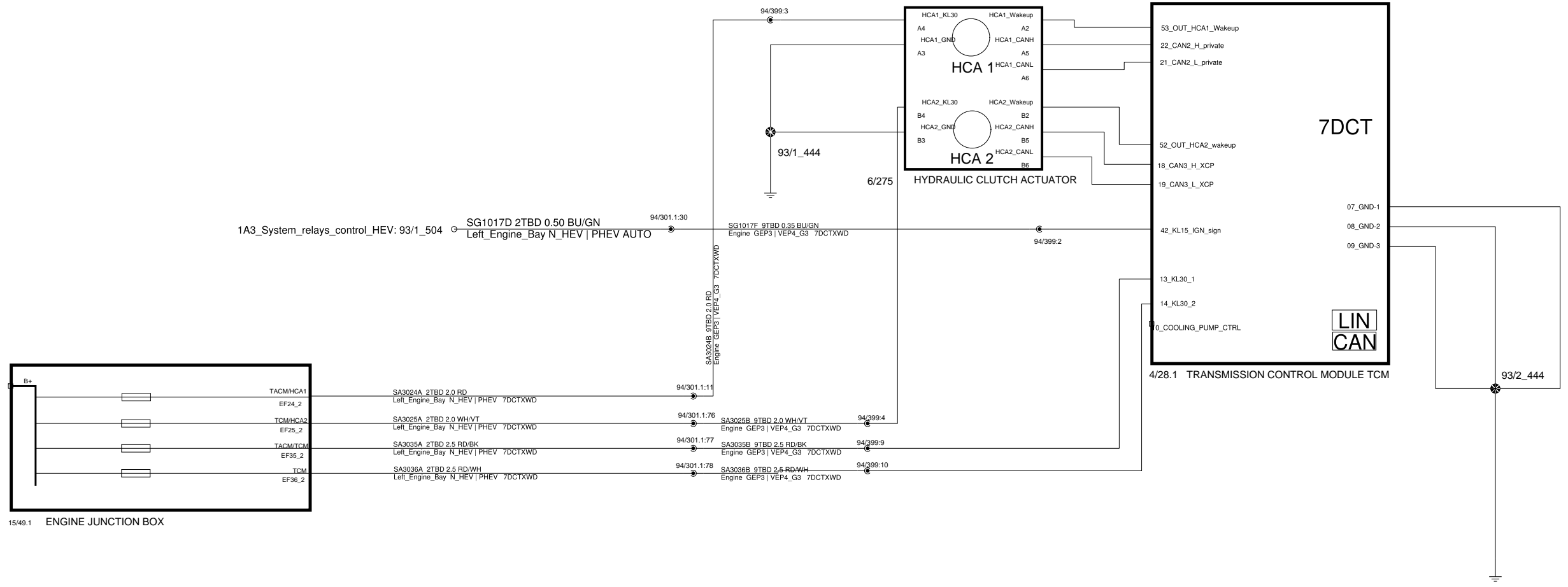

<p>The copying, distribution and utilization of this document as well as the communication of its contents to others without expressed authorization is prohibited. Offenders will be held liable for payment of damages. All rights reserved in the event of the grant of a patent, utility model or ornamental design registration.</p> <p><b>VOLVO</b> VOLVO CAR CORPORATION</p>	<b>Document title</b> CMA_622A_CC_All_5_30 3E_Automatic_Gear_Shifting_7DCT	
	<b>Document Type</b> DRAW/ELSY	<b>Release Status</b> RELEASED
	CEVT Document No 8888522365	<b>Edited</b> February/18/2022
	<b>Issue</b> 030	<b>Page No</b> 88/149



# 3E Automatic Gear Shifting

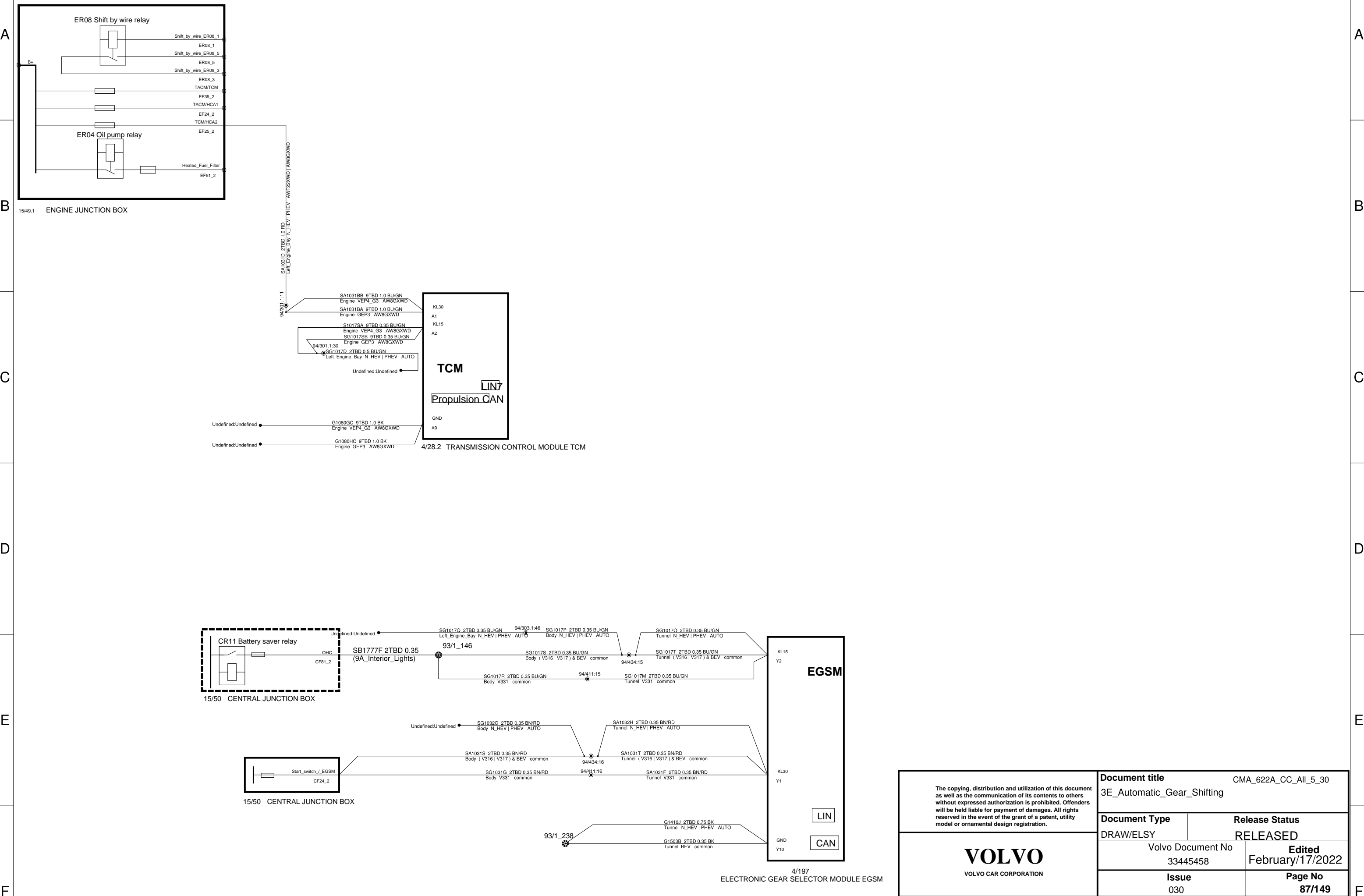

<p>The copying, distribution and utilization of this document as well as the communication of its contents to others without expressed authorization is prohibited. Offenders will be held liable for payment of damages. All rights reserved in the event of the grant of a patent, utility model or ornamental design registration.</p>		<b>Document title</b> CMA_622A_CC_All_5_30	
		3E_Automatic_Gear_Shifting	
<b>Document Type</b>		<b>Release Status</b>	
DRAW/ELSY		RELEASED	
Volvo Document No		<b>Edited</b>	
33445458		February/17/2022	
<b>Issue</b>		<b>Page No</b>	
030		87/149	



# 3G 4WD Transmission

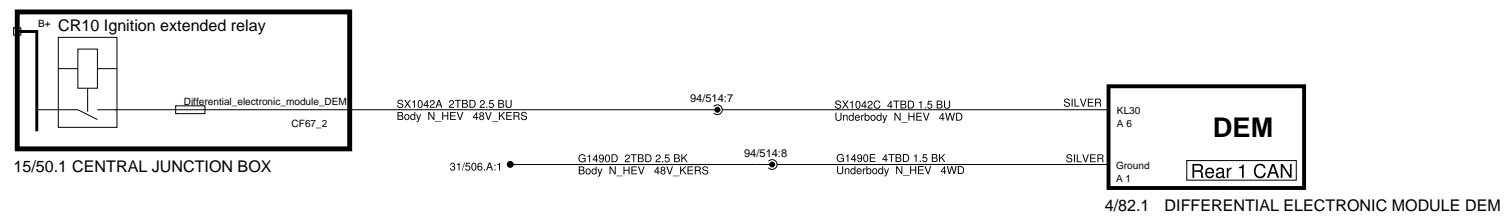

<p>The copying, distribution and utilization of this document as well as the communication of its contents to others without expressed authorization is prohibited. Offenders will be held liable for payment of damages. All rights reserved in the event of the grant of a patent, utility model or ornamental design registration.</p> <p><b>VOLVO</b> VOLVO CAR CORPORATION</p>	<b>Document title</b> CMA_622A_CC_All_5_30 3G_4WD_Transmission	
	<b>Document Type</b> DRAW/ELSY	<b>Release Status</b> RELEASED
	CEVT Document No 8888522365	<b>Edited</b> May/22/2022
	<b>Issue</b> 030	<b>Page No</b> 89/149

# 3H Manual Gear Shifting

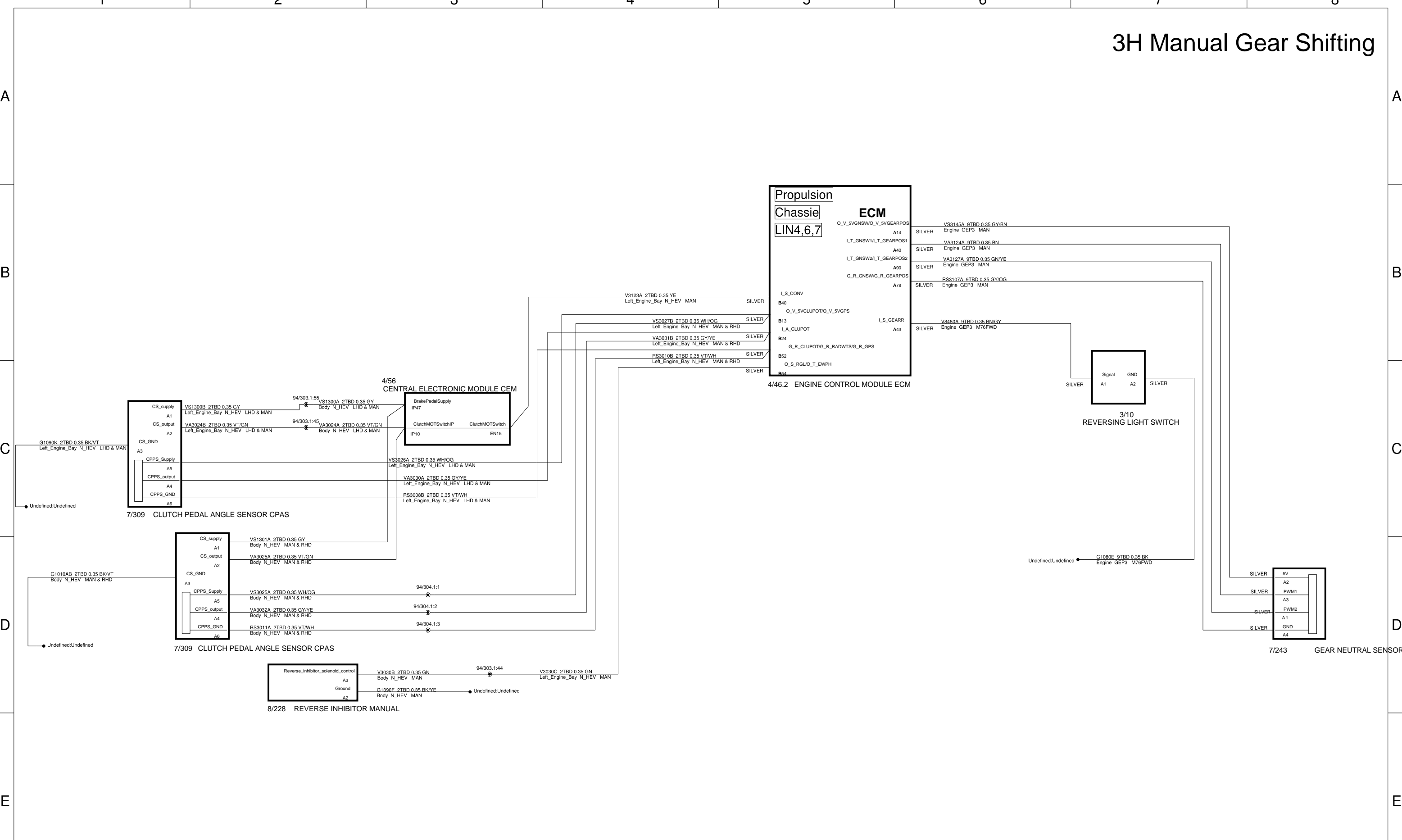

<p>The copying, distribution and utilization of this document as well as the communication of its contents to others without expressed authorization is prohibited. Offenders will be held liable for payment of damages. All rights reserved in the event of the grant of a patent, utility model or ornamental design registration.</p> <p><b>VOLVO</b> VOLVO CAR CORPORATION</p>	<b>Document title</b> CMA_622A_CC_A11_5_30 3H_Manual_Gear_Shifting	
	<b>Document Type</b> DRAW/ELSY	<b>Release Status</b> RELEASED
	CEVT Document No 8888522365	<b>Edited</b> February/16/2022
	<b>Issue</b> 030	<b>Page No</b> 90/149

# 3M Engine Cranking (HEV)

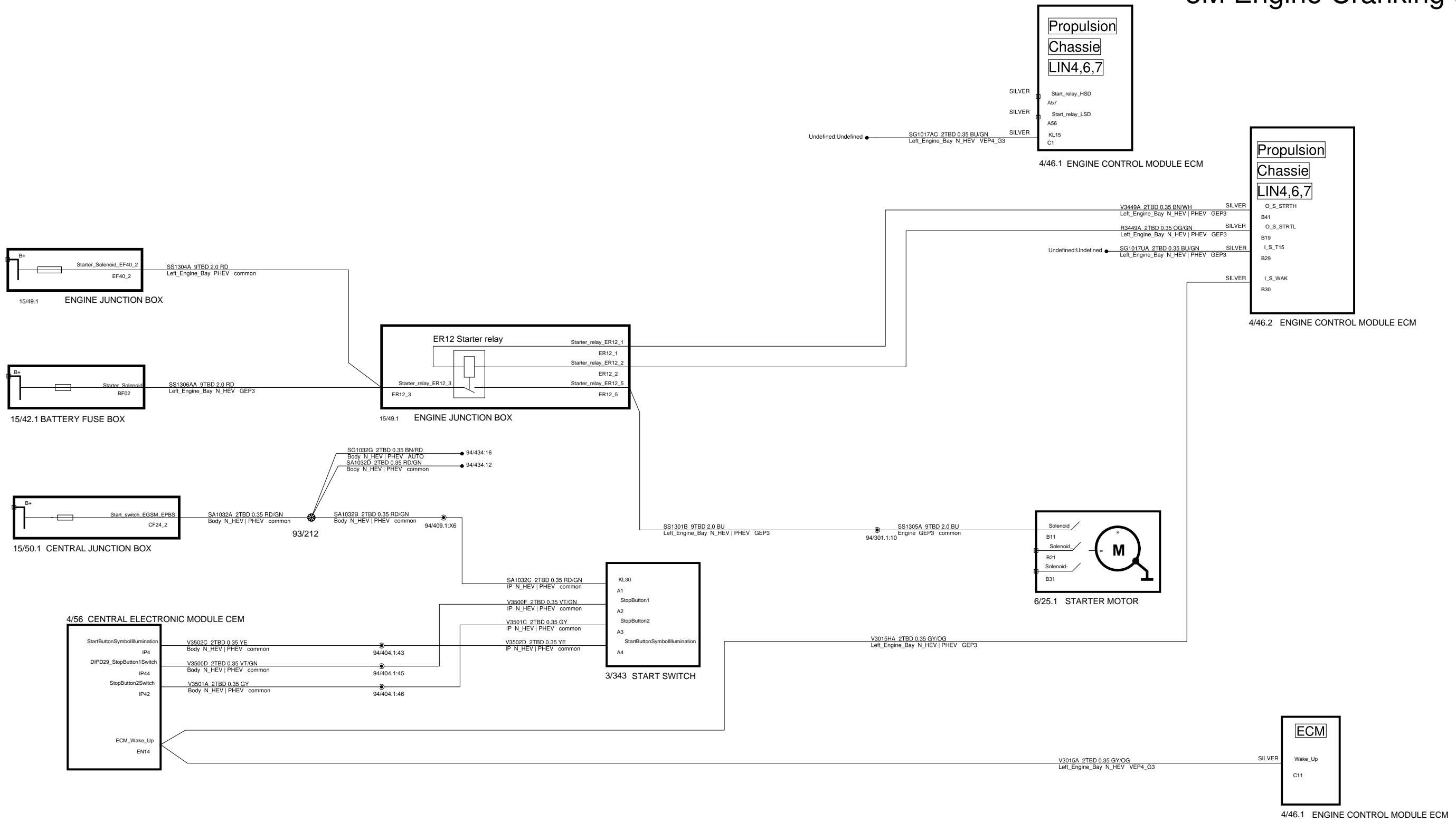

<p>The copying, distribution and utilization of this document as well as the communication of its contents to others without expressed authorization is prohibited. Offenders will be held liable for payment of damages. All rights reserved in the event of the grant of a patent, utility model or ornamental design registration.</p> <p><b>VOLVO</b> VOLVO CAR CORPORATION</p>	<b>Document title</b> CMA_622A_CC_All_5_30 3M_Engine_Cranking_Control_(HEV)	
	<b>Document Type</b> DRAW/ELSY	<b>Release Status</b> RELEASED
	CEVT Document No 8888522365	<b>Edited</b> May/24/2022
	<b>Issue</b> 030	<b>Page No</b> 91/149

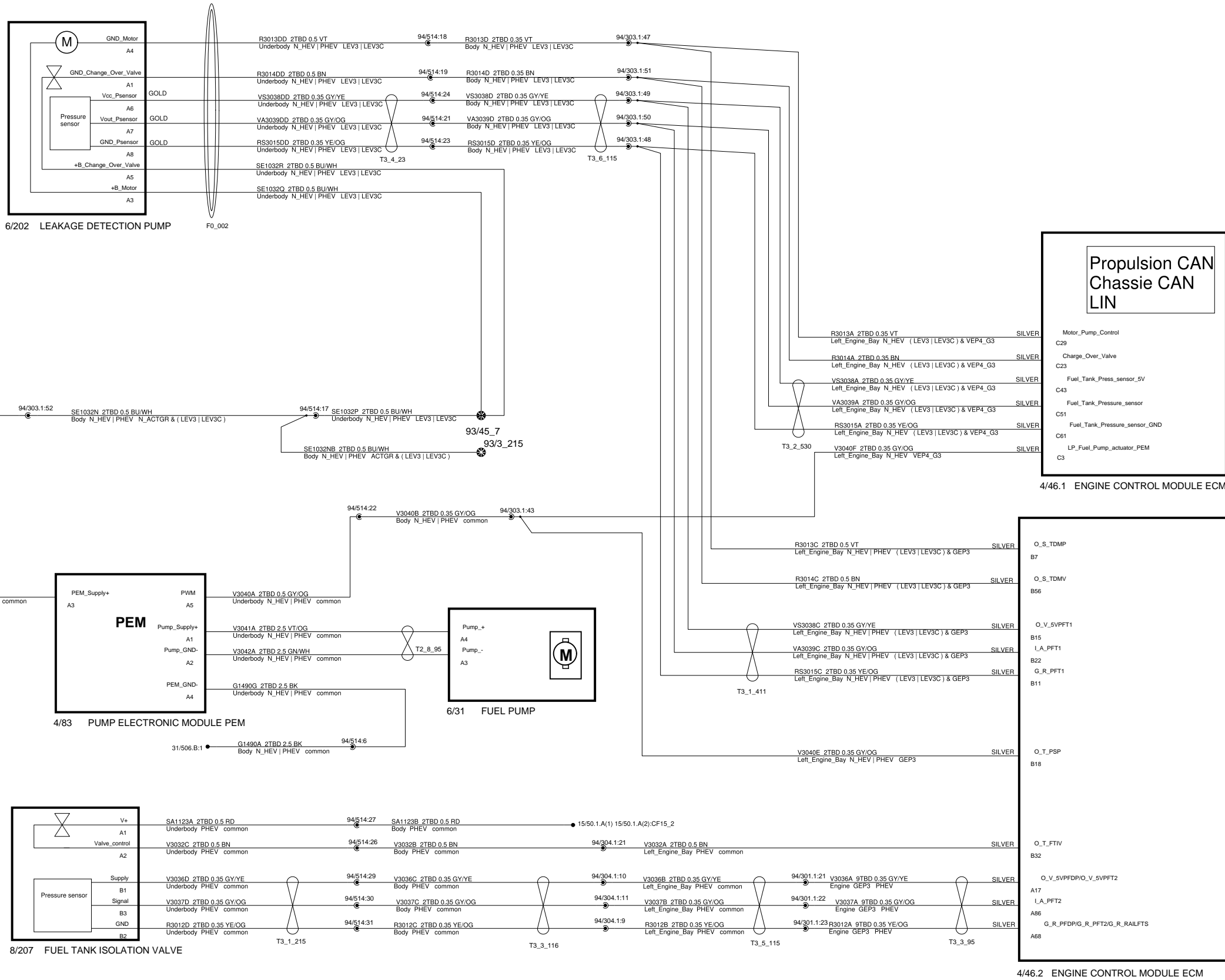

<p>The copying, distribution and utilization of this document as well as the communication of its contents to others without expressed authorization is prohibited. Offenders will be held liable for payment of damages. All rights reserved in the event of the grant of a patent, utility model or ornamental design registration.</p> <p><b>VOLVO</b> VOLVO CAR CORPORATION</p>	<b>Document title</b> CMA_622A_CC_All_5_30 3S_Fuel_Supply_Control	
	<b>Document Type</b> DRAW/ELSY	<b>Release Status</b> RELEASED
	CEVT Document No 8888522365	<b>Edited</b> March/18/2022
	<b>Issue</b> 030	<b>Page No</b> 92/149

# 4A Driver information

A

A

B

B

C

C

D

D

E

E

F

F

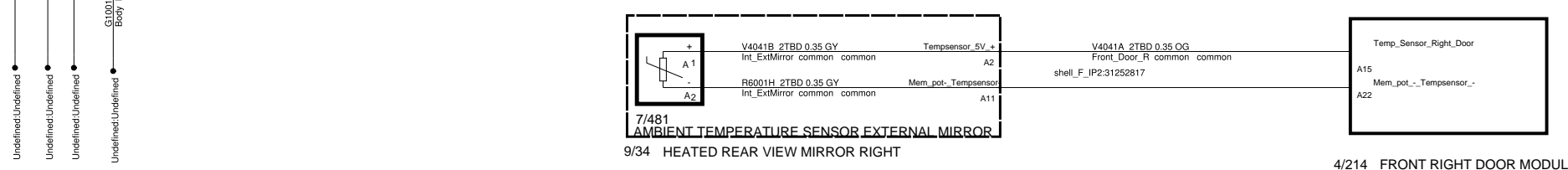
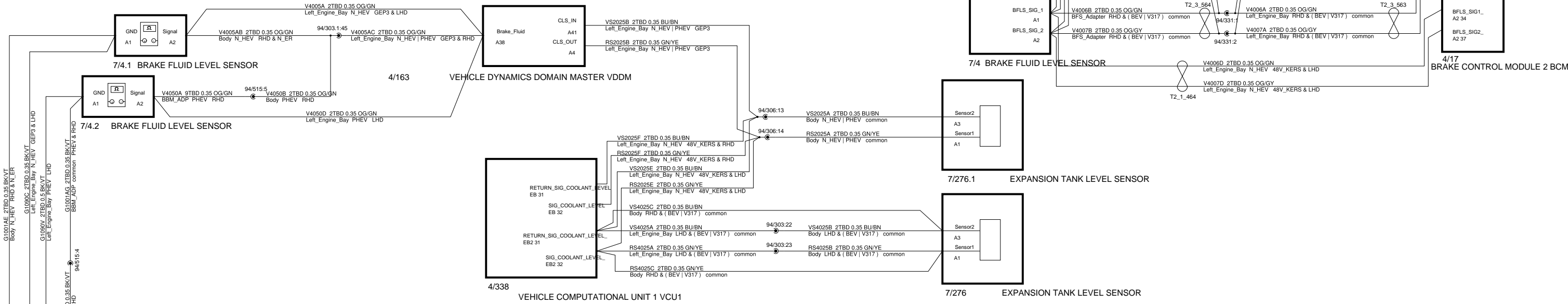
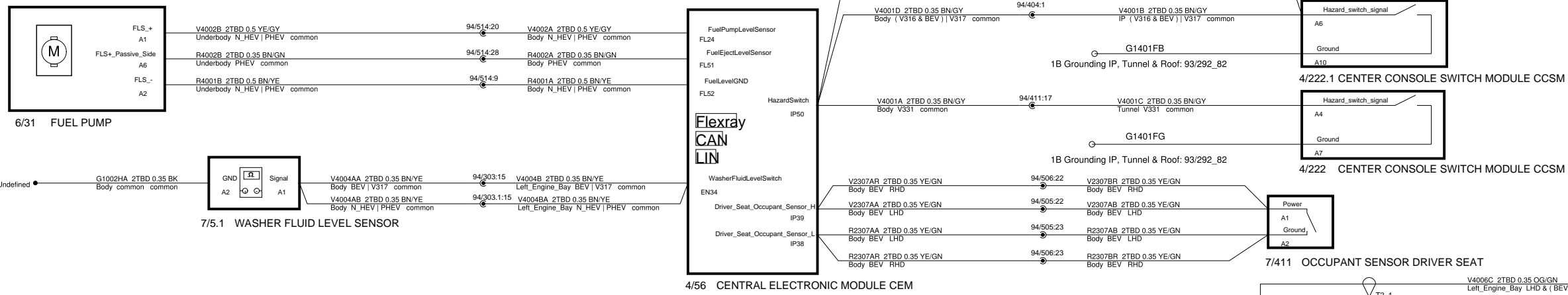
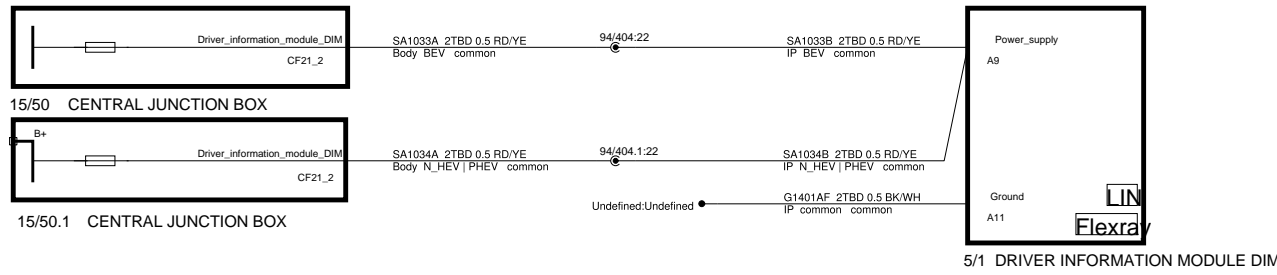

The copying, distribution and utilization of this document as well as the communication of its contents to others without expressed authorization is prohibited. Offenders will be held liable for payment of damages. All rights reserved in the event of the grant of a patent, utility model or ornamental design registration.

**VOLVO**  
VOLVO CAR CORPORATION

<b>Document title</b>		CMA_622A_CC_All_5_30	
4A_Driver_Information			
<b>Document Type</b>	<b>Release Status</b>		
DRAW/ELSY	RELEASED		
Volvo Document No		<b>Edited</b>	
33445458		May/24/2022	
<b>Issue</b>		<b>Page No</b>	
030		93/149	

# 4J1 Parking Assistance FAP

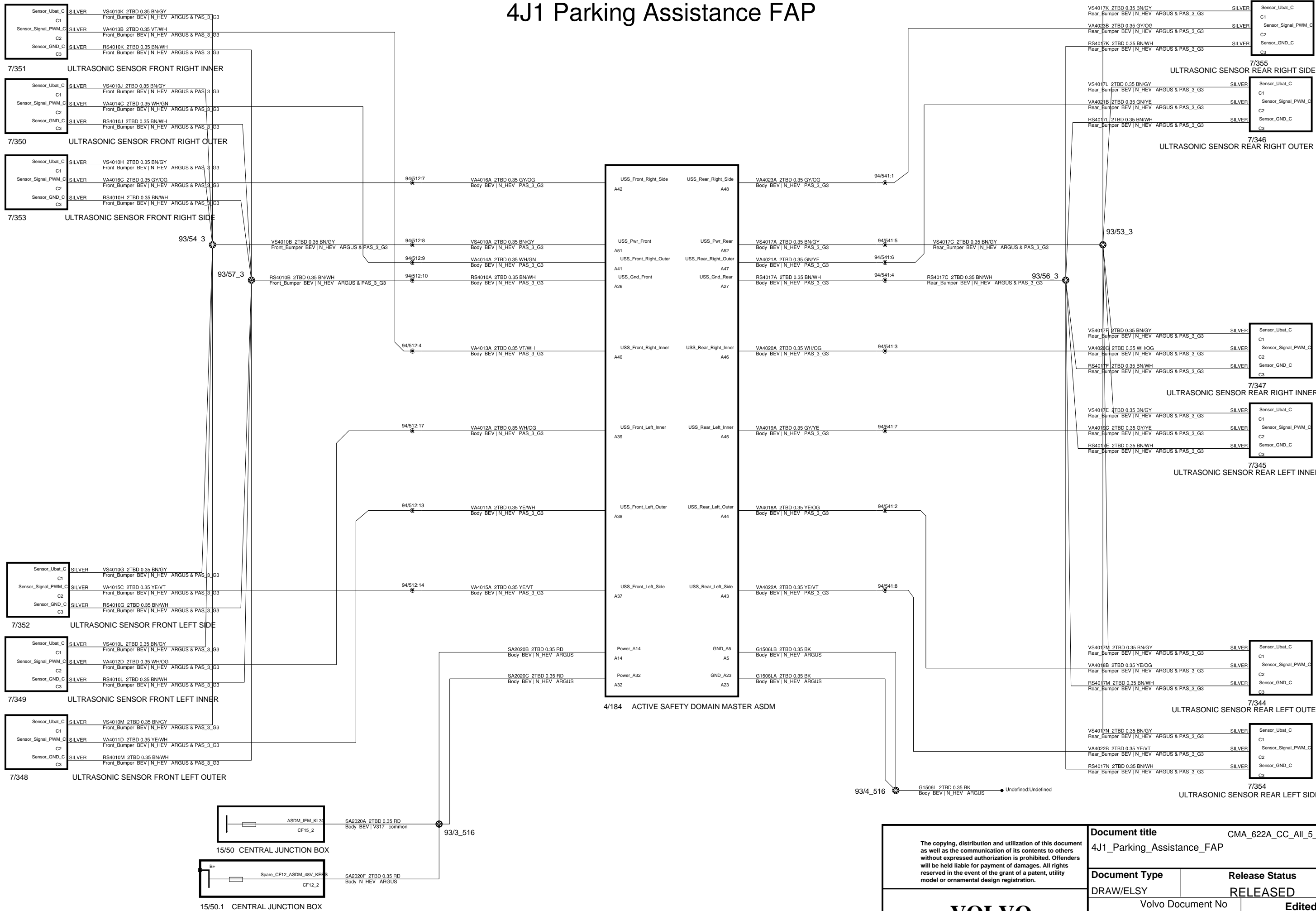

<p>The copying, distribution and utilization of this document as well as the communication of its contents to others without expressed authorization is prohibited. Offenders will be held liable for payment of damages. All rights reserved in the event of the grant of a patent, utility model or ornamental design registration.</p> <p><b>VOLVO</b> VOLVO CAR CORPORATION</p>		<p><b>Document title</b> CMA_622A_CC_All_5_30 4J1_Parking_Assistance_FAP</p>	
		<p><b>Document Type</b> DRAW/ELSY</p>	<p><b>Release Status</b> RELEASED</p>
		<p>Volvo Document No 33445458</p>	<p><b>Edited</b> May/24/2022</p>
		<p><b>Issue</b> 030</p>	<p><b>Page No</b> 94/149</p>

# 4J1 Parking Assistance NBEV

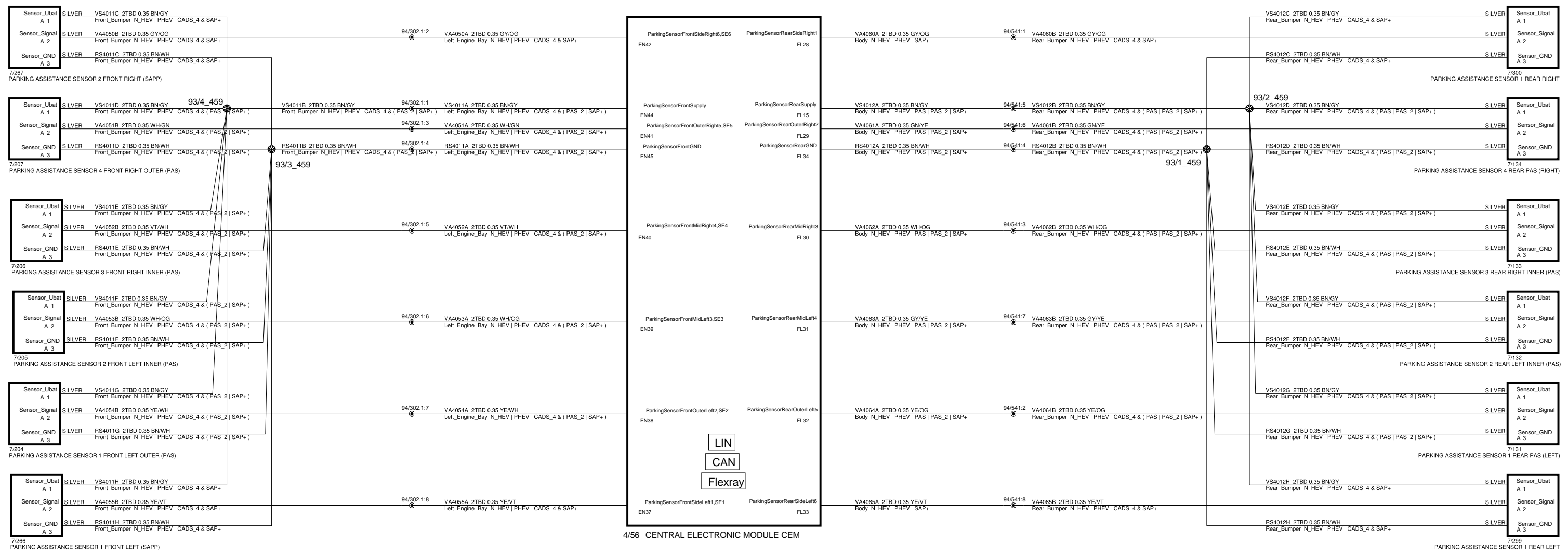

<p>The copying, distribution and utilization of this document as well as the communication of its contents to others without expressed authorization is prohibited. Offenders will be held liable for payment of damages. All rights reserved in the event of the grant of a patent, utility model or ornamental design registration.</p>		<p><b>Document title</b> CMA_622A_CC_All_5_30 4J1_Parking_Assistance_NBEV</p>	
		<p><b>Document Type</b> DRAW/ELSY</p>	<p><b>Release Status</b> RELEASED</p>
<p><b>VOLVO</b> VOLVO CAR CORPORATION</p>		<p>CEVT Document No 8888522365</p>	<p><b>Edited</b> June/16/2021</p>
		<p><b>Issue</b> 030</p>	<p><b>Page No</b> 95/149</p>



# 4J1 Parking Assistance PAS PAS\_2

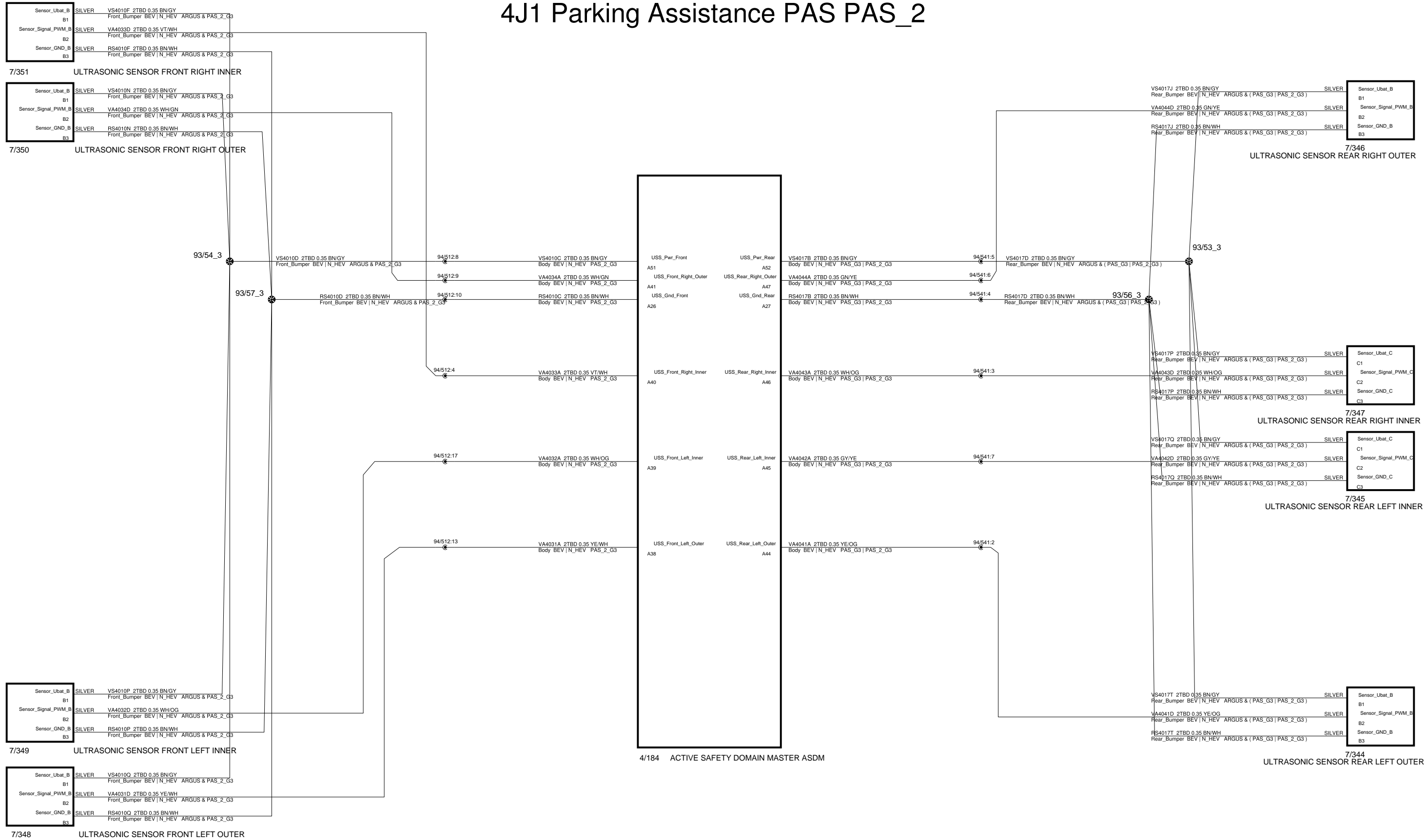

<p>The copying, distribution and utilization of this document as well as the communication of its contents to others without expressed authorization is prohibited. Offenders will be held liable for payment of damages. All rights reserved in the event of the grant of a patent, utility model or ornamental design registration.</p> <p><b>VOLVO</b> VOLVO CAR CORPORATION</p>	<b>Document title</b> CMA_622A_CC_All_5_30 4J1_Parking_Assistance_PAS_PAS2	
	<b>Document Type</b> DRAW/ELSY	<b>Release Status</b> RELEASED
	CEVT Document No 8888522365	<b>Edited</b> June/16/2021
	<b>Issue</b> 030	<b>Page No</b> 96/149

# 4J2B Lane Change Aid

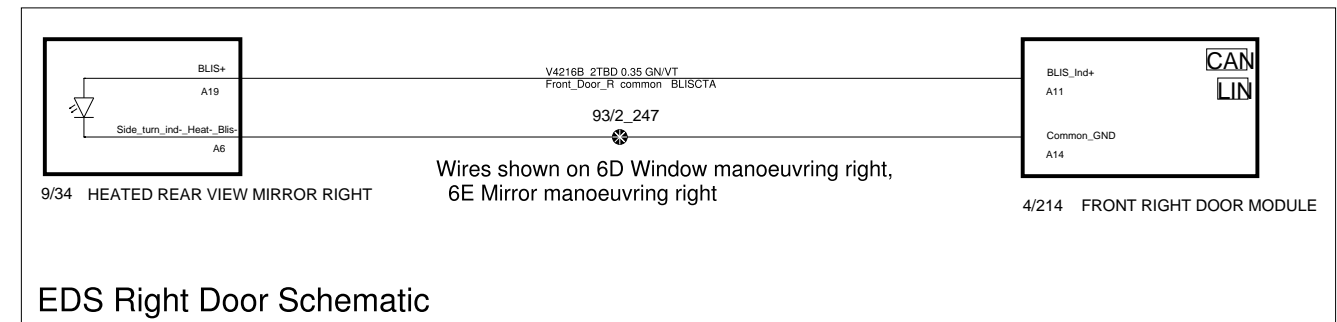
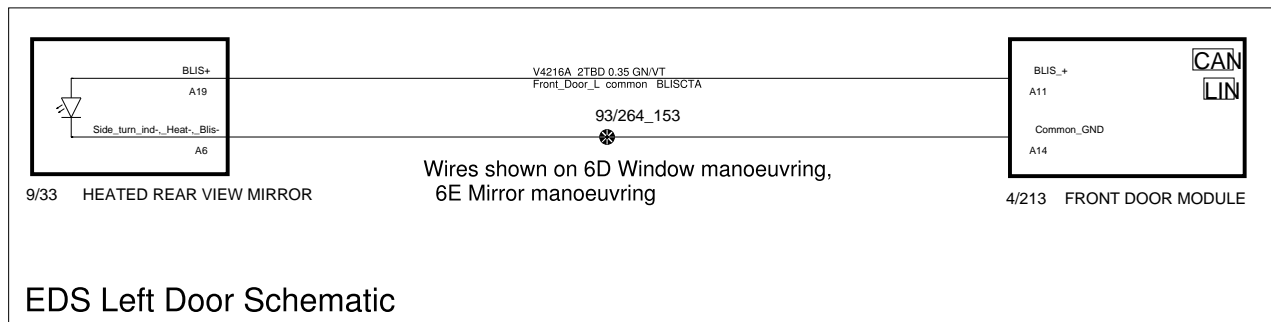
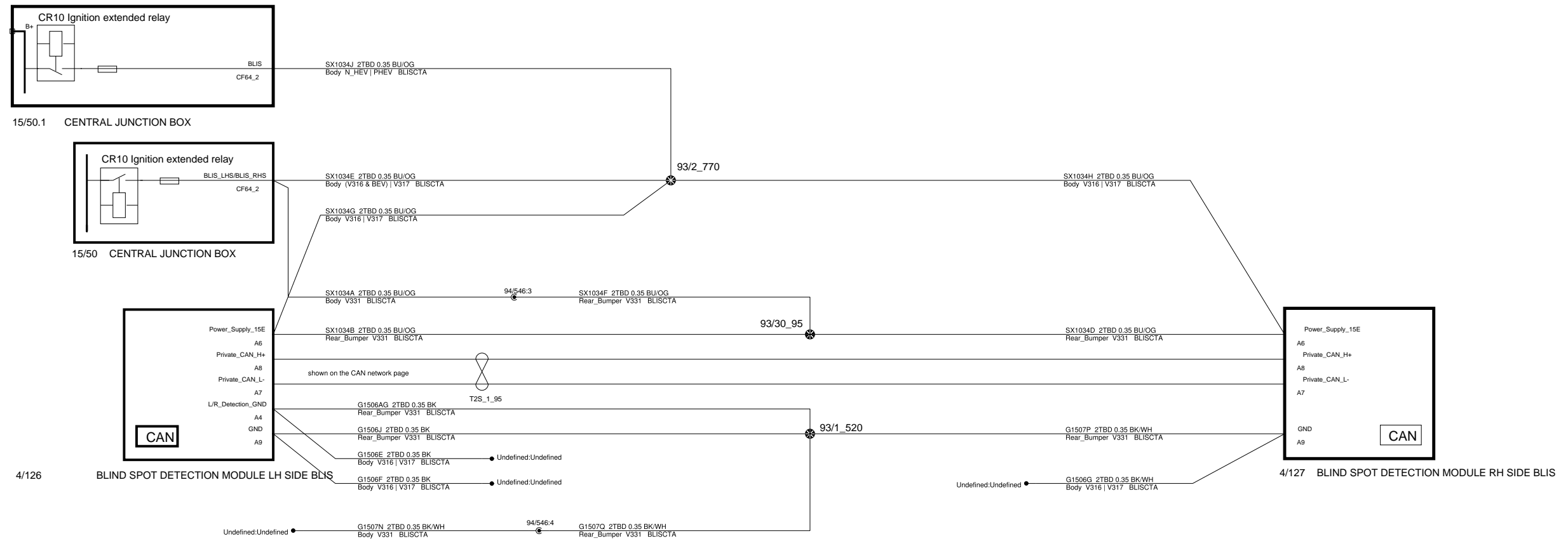

<p>The copying, distribution and utilization of this document as well as the communication of its contents to others without expressed authorization is prohibited. Offenders will be held liable for payment of damages. All rights reserved in the event of the grant of a patent, utility model or ornamental design registration.</p> <p><b>VOLVO</b> VOLVO CAR CORPORATION</p>	<b>Document title</b> CMA_622A_CC_All_5_30 4J2B_Lane_Change_Aid	
	<b>Document Type</b> DRAW/ELSY	<b>Release Status</b> RELEASED
	Volvo Document No 33445458	<b>Edited</b> May/24/2022
	<b>Issue</b> 030	<b>Page No</b> 97/149

# 4J4 PAC Visualisation/Driver Assistance

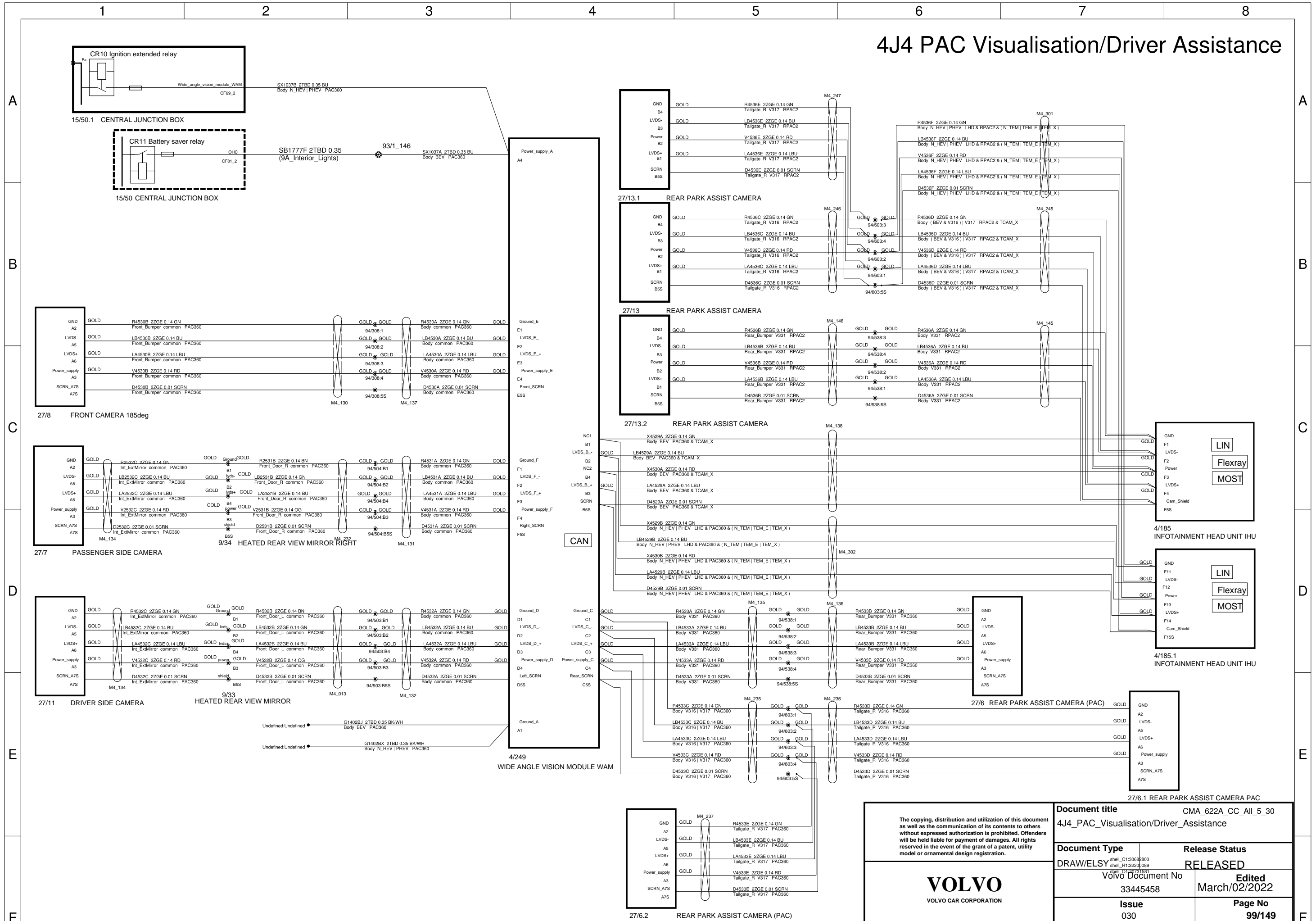

The copying, distribution and utilization of this document as well as the communication of its contents to others without expressed authorization is prohibited. Offenders will be held liable for payment of damages. All rights reserved in the event of the grant of a patent, utility model or ornamental design registration.

**VOLVO**  
VOLVO CAR CORPORATION

<b>Document title</b> CMA_622A_CC_Ali_5_30 4J4_PAC_Visualisation/Driver_Assistance	
<b>Document Type</b> DRAW/ELSY	<b>Release Status</b> RELEASED
<b>Issue</b> 030	<b>Page No</b> 99/149

**Volvo Document No**  
33445458

**Edited**  
March/02/2022

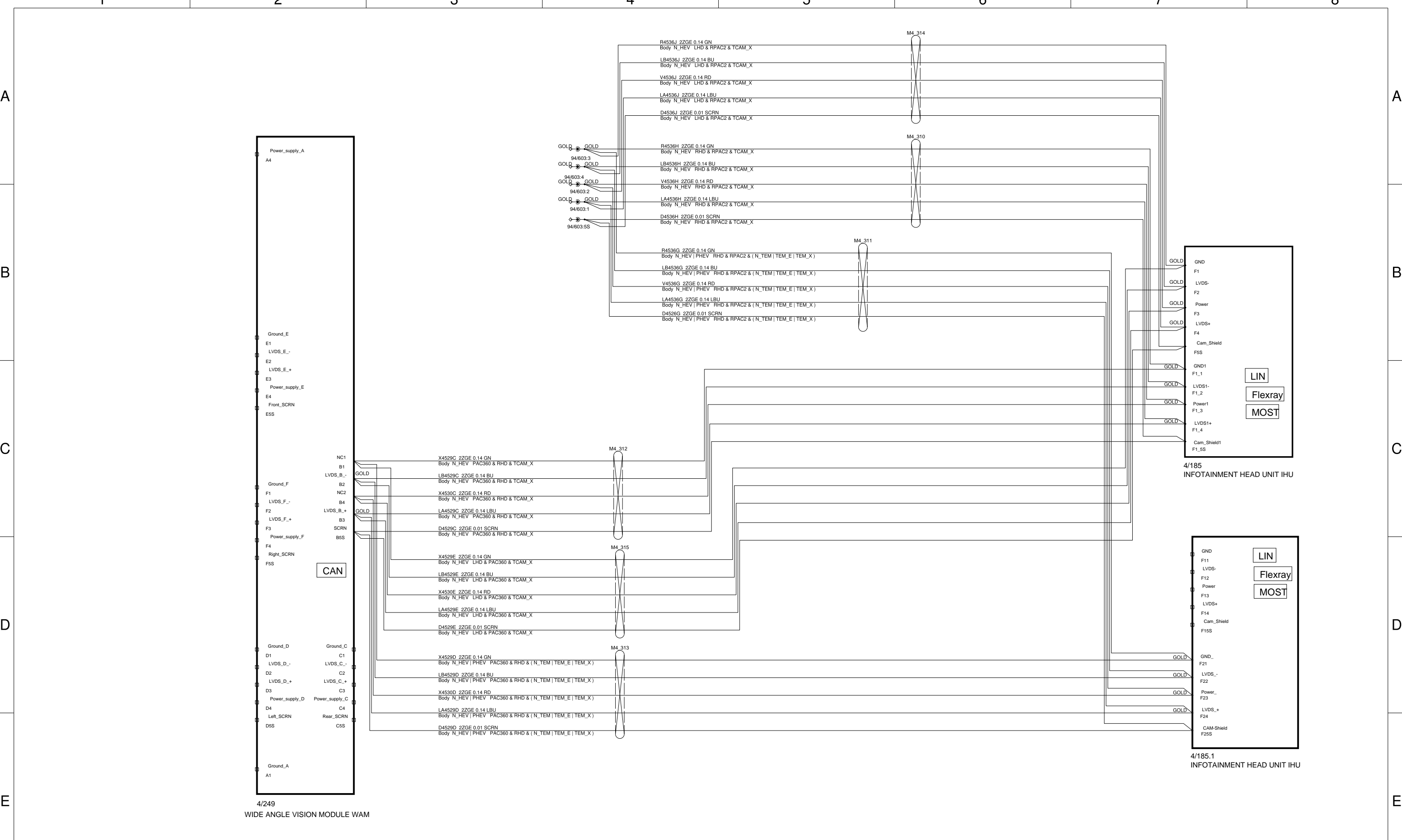

4/249  
WIDE ANGLE VISION MODULE WAM

4/185  
INFOTAINMENT HEAD UNIT IHU

4/185.1  
INFOTAINMENT HEAD UNIT IHU

<p>The copying, distribution and utilization of this document as well as the communication of its contents to others without expressed authorization is prohibited. Offenders will be held liable for payment of damages. All rights reserved in the event of the grant of a patent, utility model or ornamental design registration.</p> <p><b>VOLVO</b> VOLVO CAR CORPORATION</p>	<p><b>Document title</b> CMA_622A_CC_All_5_30 4J4_PAC_Visualisation</p>	
	<p><b>Document Type</b> DRAW/ELSY</p>	<p><b>Release Status</b> RELEASED</p>
	<p>CEVT Document No 8888522365</p>	<p><b>Edited</b> February/17/2022</p>
	<p><b>Issue</b> 030</p>	<p><b>Page No</b> 98/149</p>

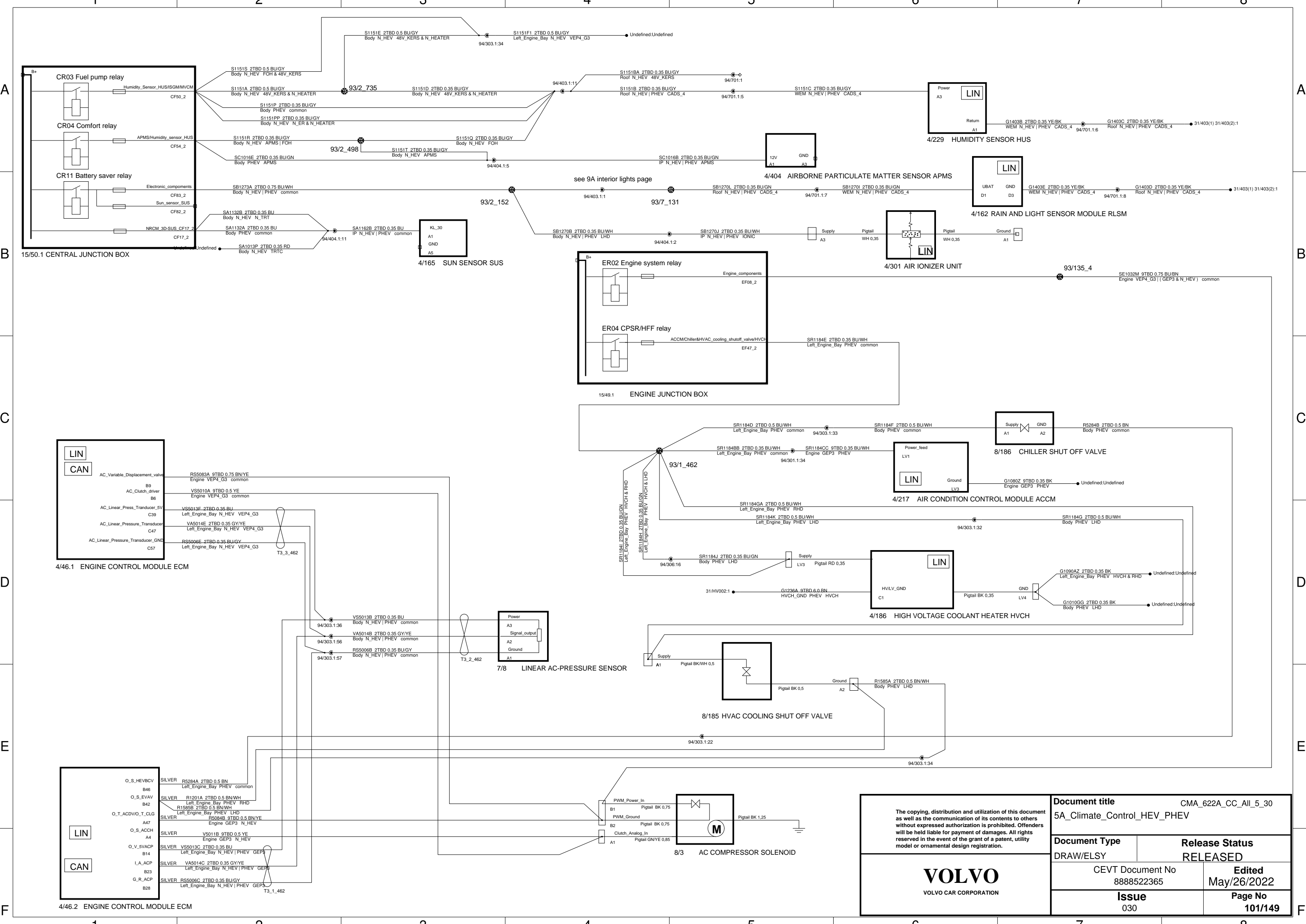

The copying, distribution and utilization of this document as well as the communication of its contents to others without expressed authorization is prohibited. Offenders will be held liable for payment of damages. All rights reserved in the event of the grant of a patent, utility model or ornamental design registration.

**VOLVO**  
VOLVO CAR CORPORATION

<b>Document title</b> CMA_622A_CC_All_5_30 5A_Climate_Control_HEV_PHEV	
<b>Document Type</b> DRAW/ELSY	<b>Release Status</b> RELEASED
CEVT Document No 8888522365	<b>Edited</b> May/26/2022
<b>Issue</b> 030	<b>Page No</b> 101/149

# 5A Climate Control HVAC ECC

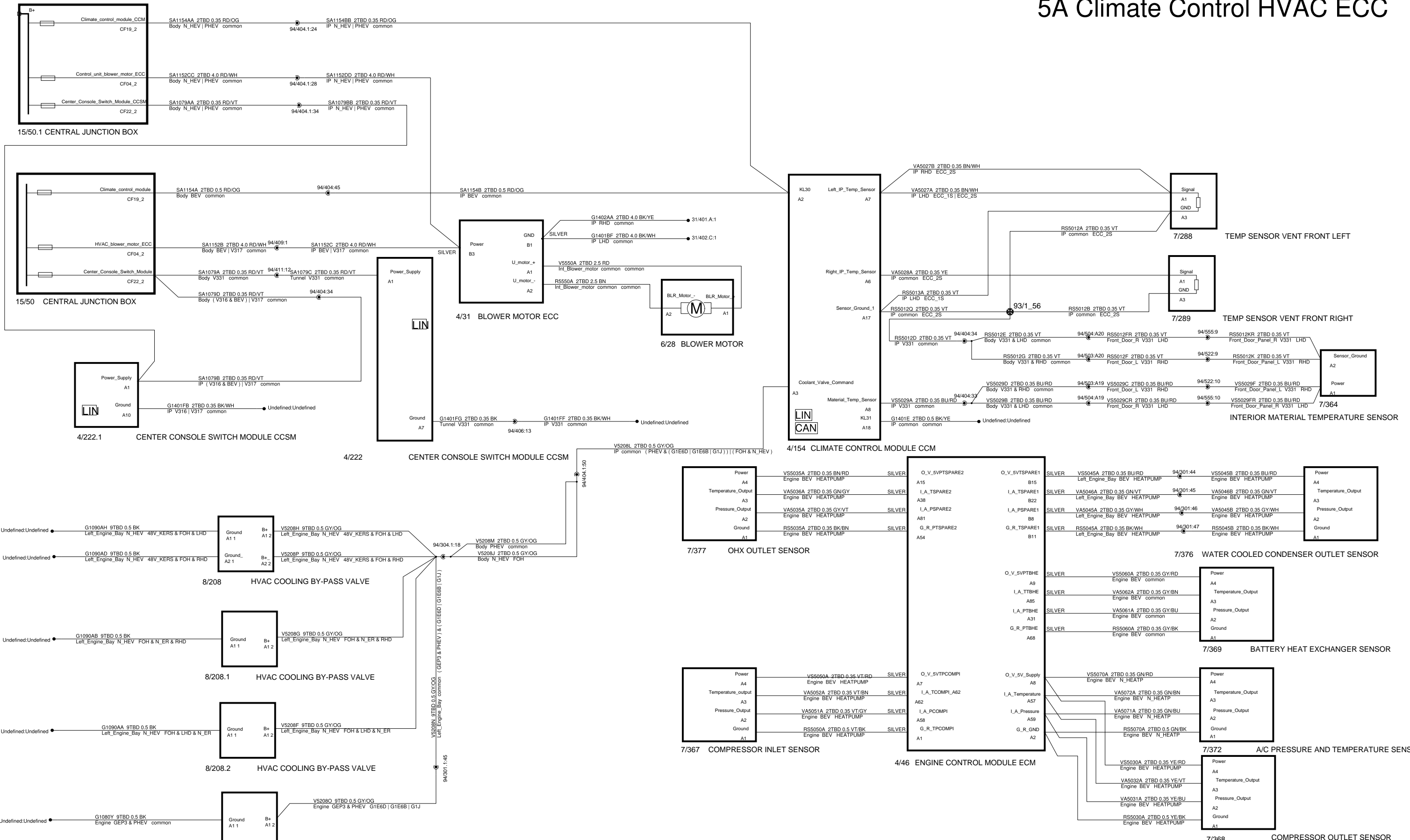

<p>The copying, distribution and utilization of this document as well as the communication of its contents to others without expressed authorization is prohibited. Offenders will be held liable for payment of damages. All rights reserved in the event of the grant of a patent, utility model or ornamental design registration.</p> <p><b>VOLVO</b> VOLVO CAR CORPORATION</p>		<p><b>Document title</b> CMA_622A_CC_All_5_30 5A_Climate_Control_HVAC_ECC</p>	
		<p><b>Document Type</b> DRAW/ELSY</p>	<p><b>Release Status</b> RELEASED</p>
		<p>Volvo Document No 33445458</p>	<p><b>Edited</b> May/26/2022</p>
		<p><b>Issue</b> 030</p>	<p><b>Page No</b> 102/149</p>

# 5A Climate Control

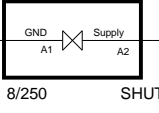
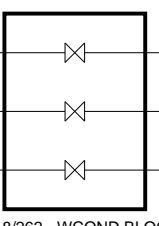
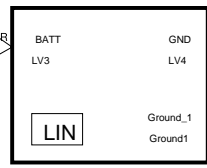
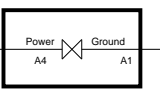
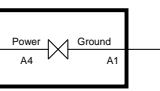
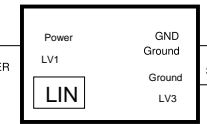
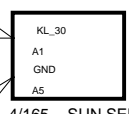
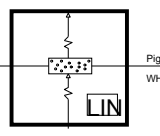
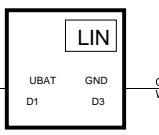
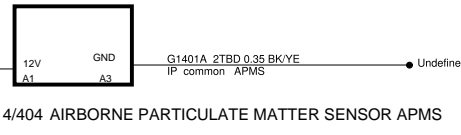
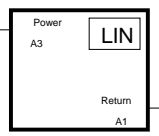
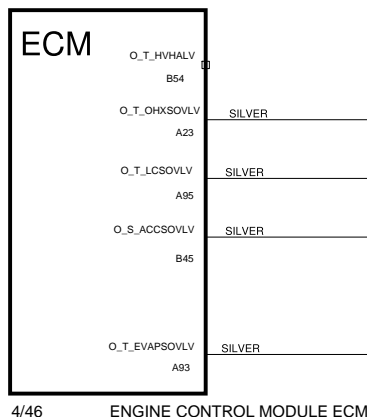
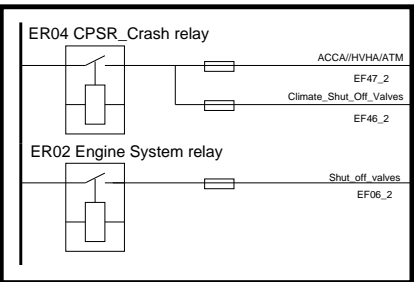
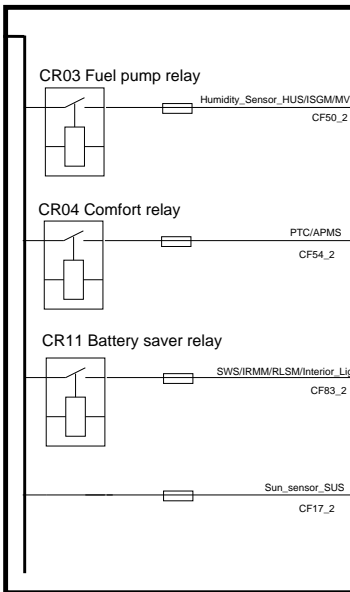
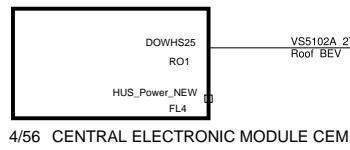

<p>The copying, distribution and utilization of this document as well as the communication of its contents to others without expressed authorization is prohibited. Offenders will be held liable for payment of damages. All rights reserved in the event of the grant of a patent, utility model or ornamental design registration.</p> <p><b>VOLVO</b> VOLVO CAR CORPORATION</p>	<b>Document title</b> CMA_622A_CC_All_5_30	
	5A_Climate_Control	
	<b>Document Type</b>	<b>Release Status</b>
	DRAW/ELSY	RELEASED
	Volvo Document No 33445458	<b>Edited</b> February/17/2022
<b>Issue</b> 030	<b>Page No</b> 100/149	

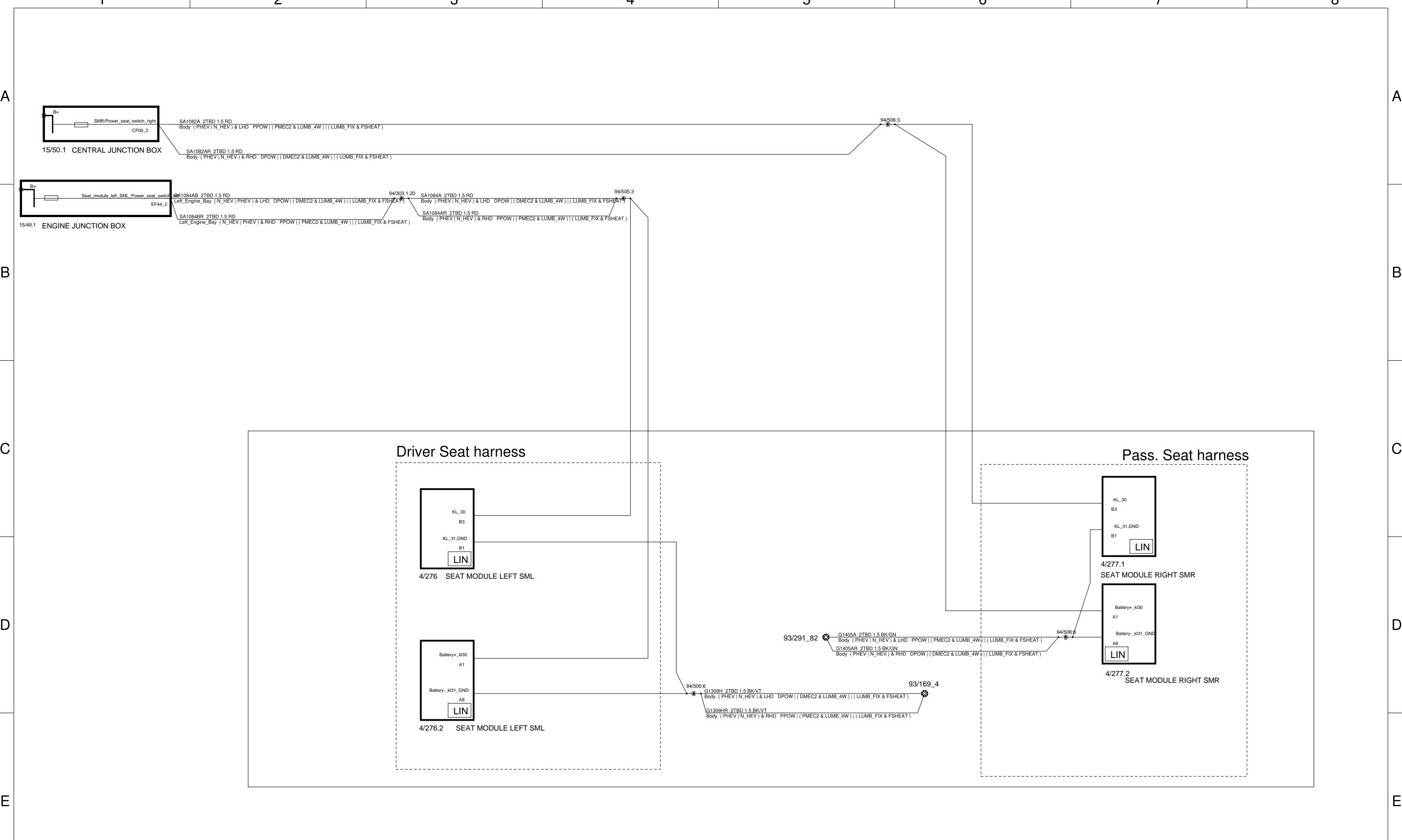

<p>The copying, distribution and utilization of this document as well as the communication of its contents to others without expressed authorization is prohibited. Offenders will be held liable for payment of damages. All rights reserved in the event of the grant of a patent, utility model or ornamental design registration.</p> <p><b>VOLVO</b> VOLVO CAR CORPORATION</p>	<b>Document title</b> CMA_622A_CC_All_5_30 5B_Front_Seat_Comfort_PHEV	
	<b>Document Type</b> DRAW/ELSY	<b>Release Status</b> RELEASED
	CEVT Document No 8888522365	<b>Edited</b> May/26/2022
	<b>Issue</b> 030	<b>Page No</b> 104/149



# 5B Front Seat Comfort

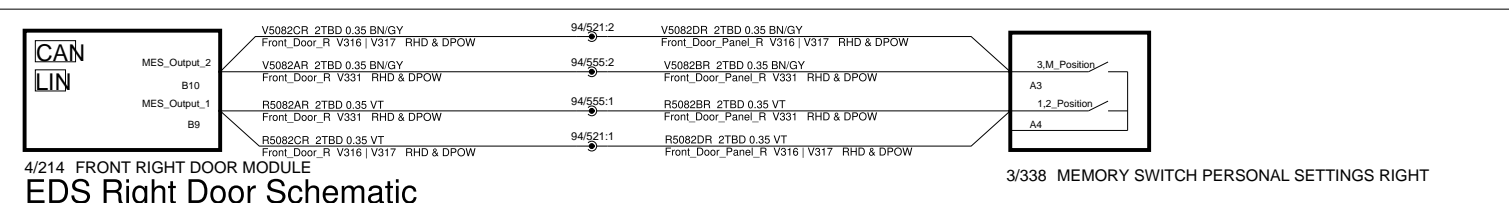
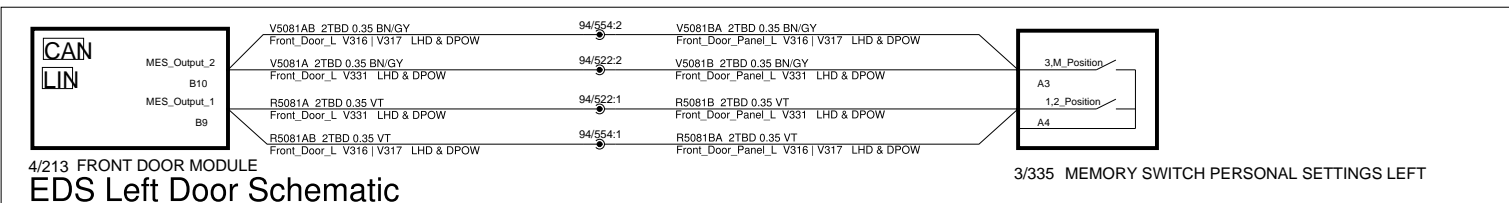
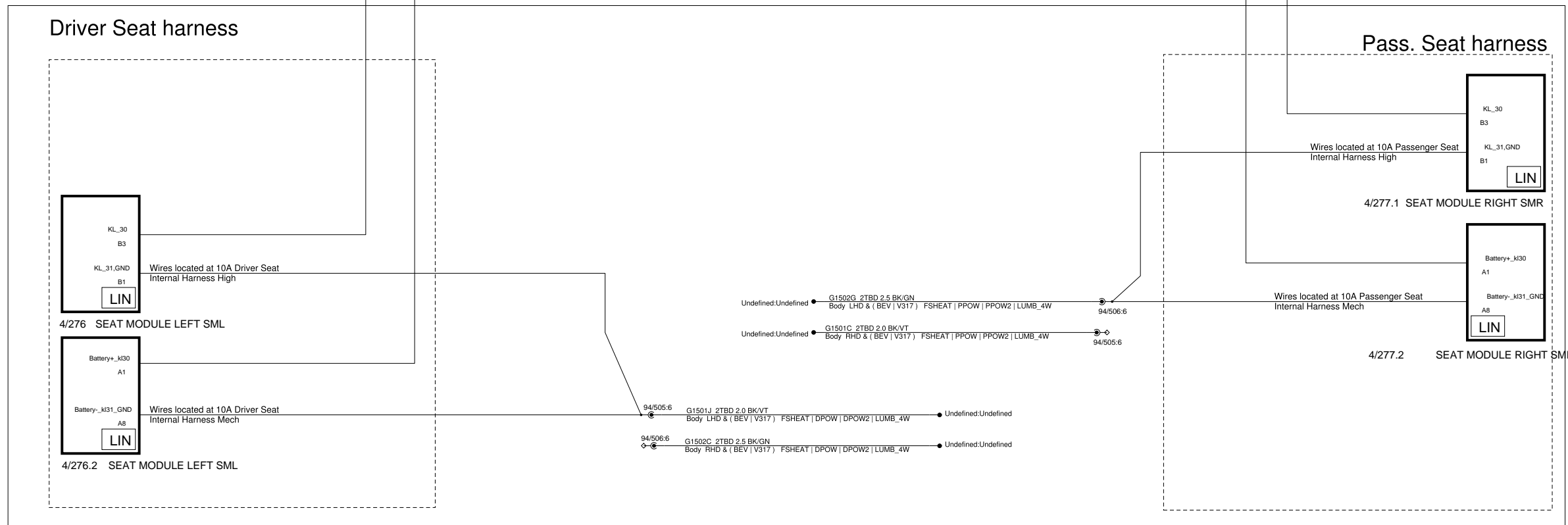
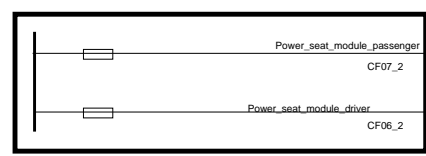

The copying, distribution and utilization of this document as well as the communication of its contents to others without expressed authorization is prohibited. Offenders will be held liable for payment of damages. All rights reserved in the event of the grant of a patent, utility model or ornamental design registration.

**VOLVO**  
VOLVO CAR CORPORATION

<b>Document title</b> 5B_Front_Seat_Comfort		CMA_622A_CC_All_5_30	
<b>Document Type</b> DRAW/ELSY	<b>Release Status</b> RELEASED		
Volvo Document No 33445458		<b>Edited</b> March/04/2022	
<b>Issue</b> 030		<b>Page No</b> 103/149	

# Rear Seat Harness

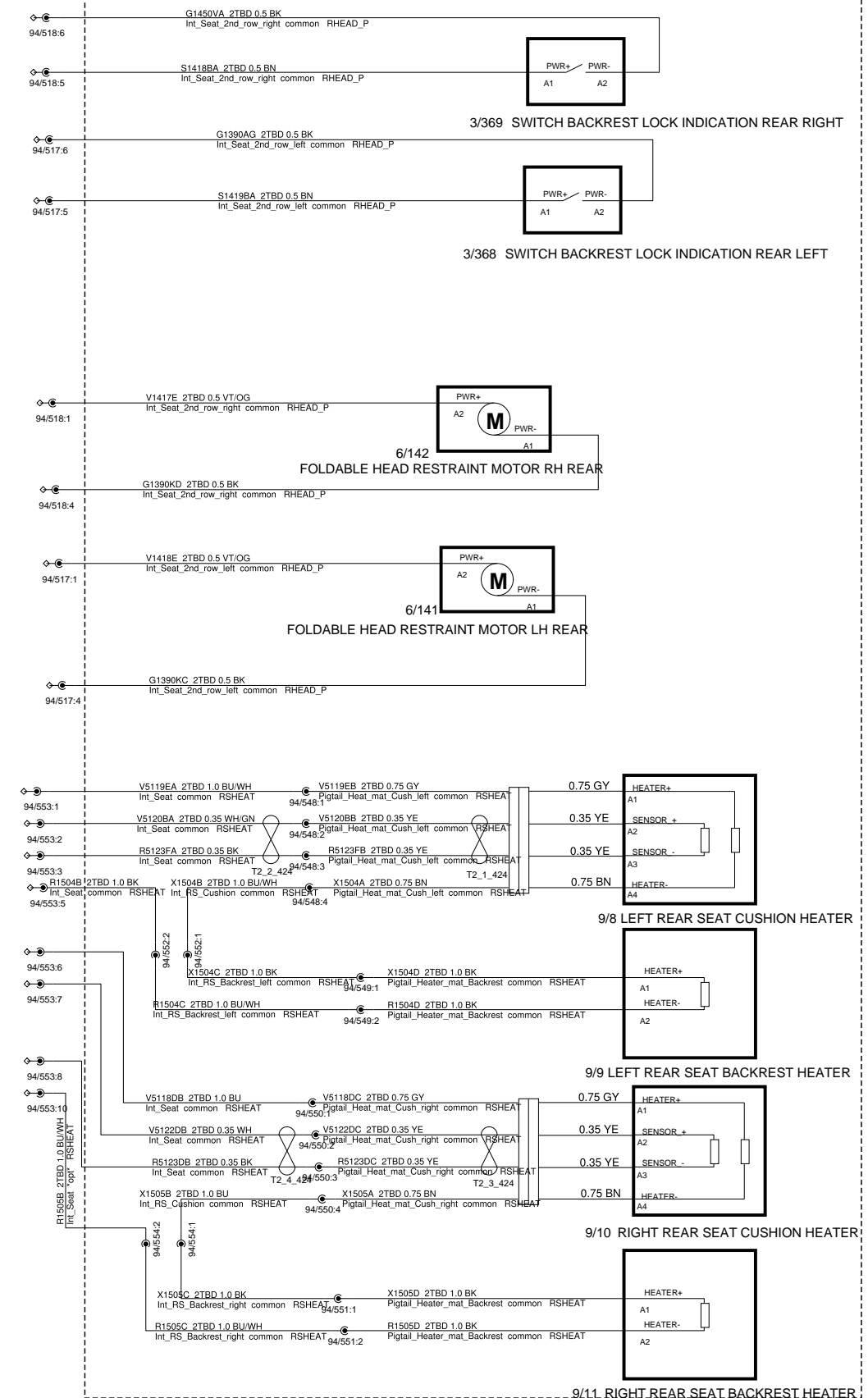

The copying, distribution and utilization of this document as well as the communication of its contents to others without expressed authorization is prohibited. Offenders will be held liable for payment of damages. All rights reserved in the event of the grant of a patent, utility model or ornamental design registration.

**VOLVO**  
VOLVO CAR CORPORATION

<b>Document title</b>		CMA_622A_CC_All_5_30	
5B_Rear_Seat_Comfort_PHEV			
<b>Document Type</b>	<b>Release Status</b>		
DRAW/ELSY	RELEASED		
CEVT Document No		<b>Edited</b>	
8888522365		May/26/2022	
<b>Issue</b>		<b>Page No</b>	
030		106/149	

# 5B Rear Seat Comfort

## Rear Seat Harness

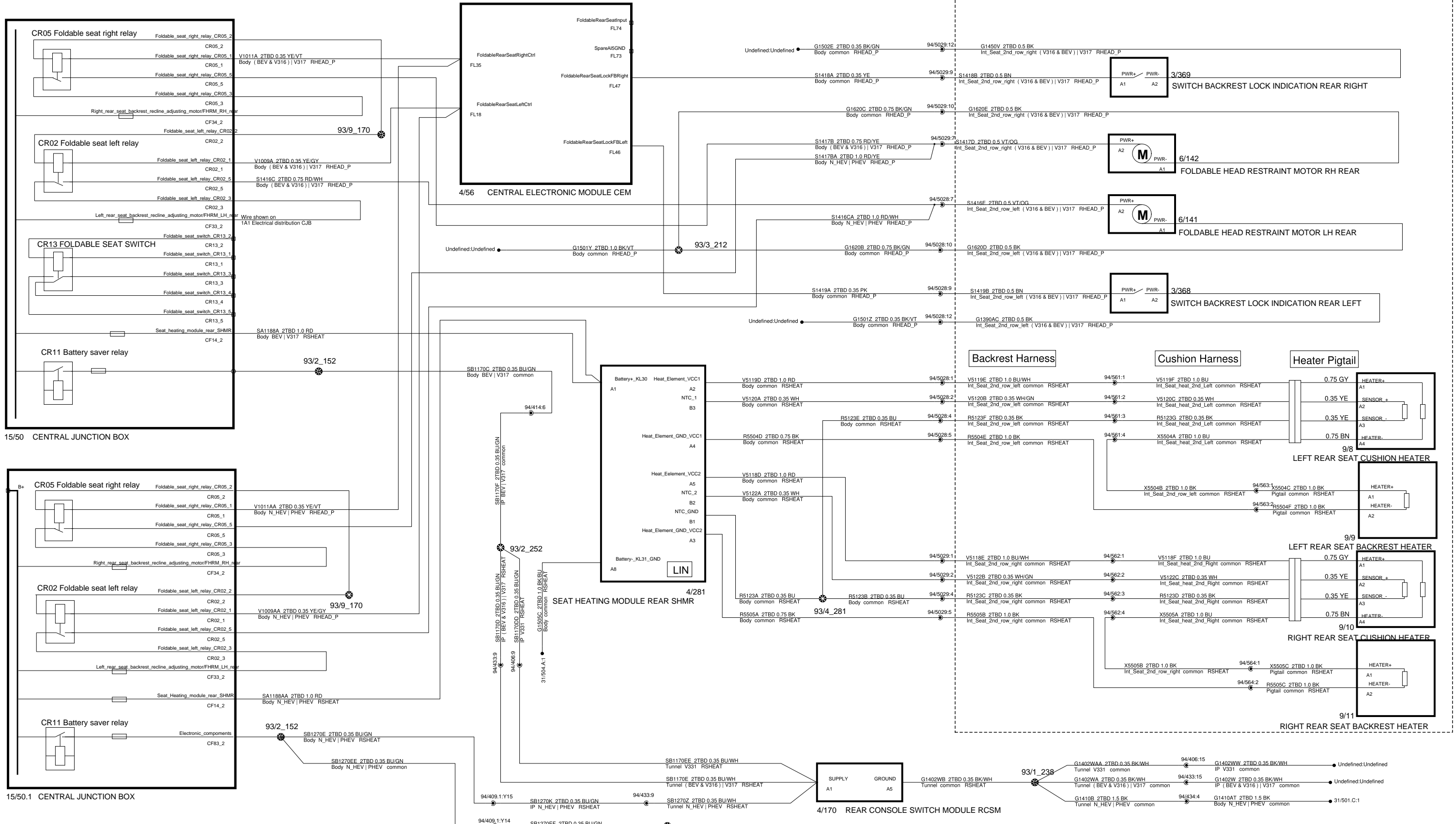

Continues though  
- 8A\_Exterior\_Light\_Front  
- 9A\_Interior\_Lights

<p>The copying, distribution and utilization of this document as well as the communication of its contents to others without expressed authorization is prohibited. Offenders will be held liable for payment of damages. All rights reserved in the event of the grant of a patent, utility model or ornamental design registration.</p>	
<p><b>VOLVO</b> VOLVO CAR CORPORATION</p>	
<p><b>Document title</b> CMA_622A_CC_All_5_30 5B_Rear_Seat_Comfort</p>	
<p><b>Document Type</b> DRAW/ELSY</p>	<p><b>Release Status</b> RELEASED</p>
<p>Volvo Document No 33445458</p>	<p><b>Edited</b> June/16/2021</p>
<p><b>Issue</b> 030</p>	<p><b>Page No</b> 105/149</p>

# 5F1 Passenger Compartment Pre-Conditioning

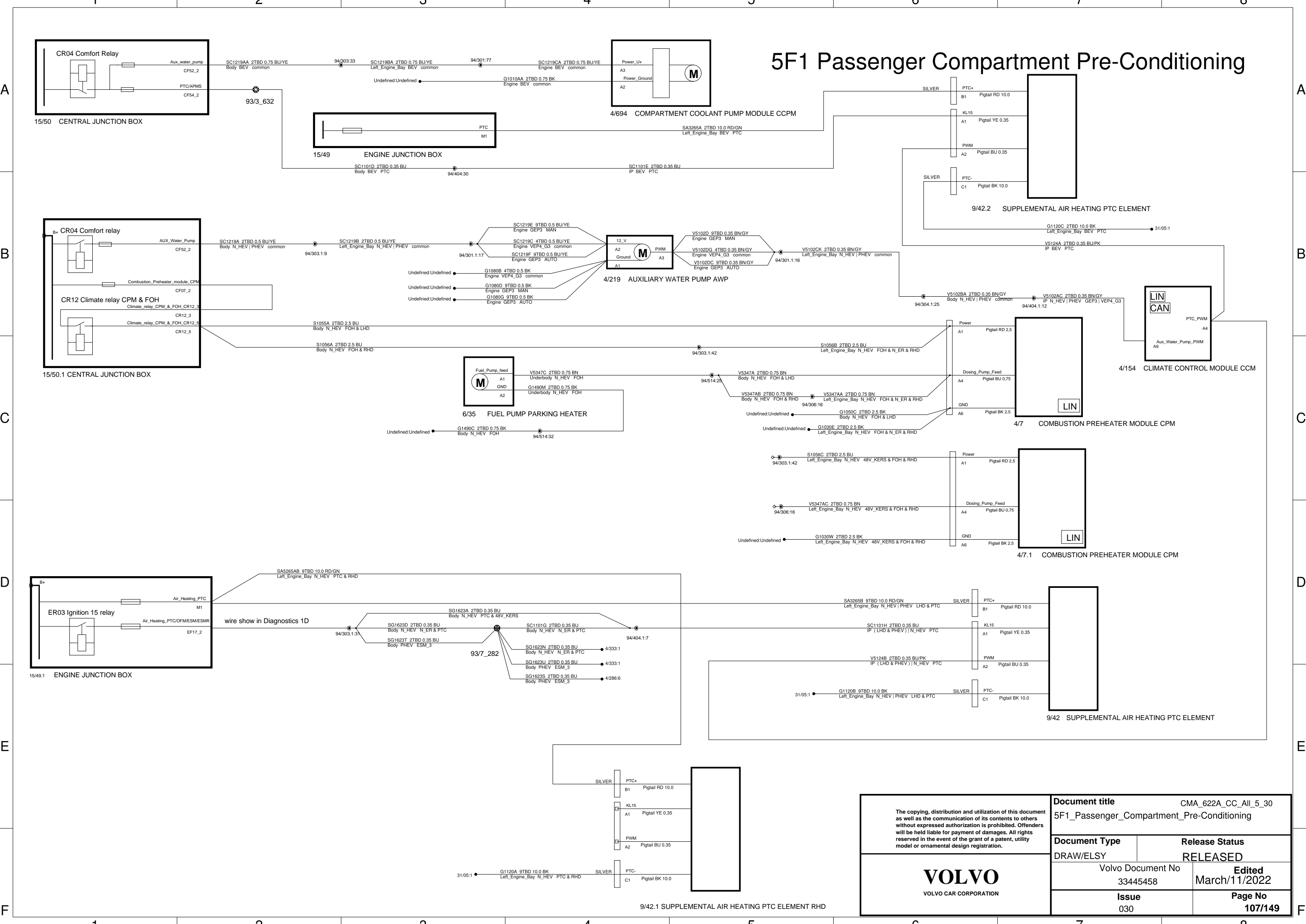

<p>The copying, distribution and utilization of this document as well as the communication of its contents to others without expressed authorization is prohibited. Offenders will be held liable for payment of damages. All rights reserved in the event of the grant of a patent, utility model or ornamental design registration.</p>		<p><b>Document title</b> CMA_622A_CC_All_5_30 5F1_Passenger_Compartment_Pre-Conditioning</p>	
		<p><b>Document Type</b> DRAW/ELSY</p>	<p><b>Release Status</b> RELEASED</p>
<p><b>VOLVO</b> VOLVO CAR CORPORATION</p>		<p>Volvo Document No 33445458</p>	<p><b>Edited</b> March/11/2022</p>
		<p><b>Issue</b> 030</p>	<p><b>Page No</b> 107/149</p>

# 5G Steering Wheel Heating

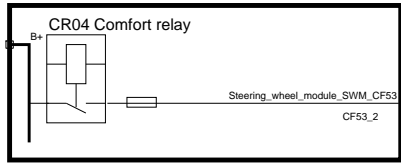

15/50.1 CENTRAL JUNCTION BOX

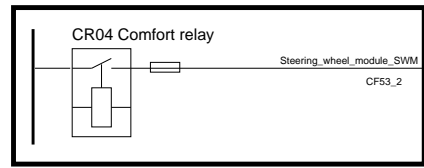

15/50 CENTRAL JUNCTION BOX

SC1246AA 2TBD 1.0 BU/BN  
Body N\_HEV | PHEV HEATSTER

94/404.1:17

SC1247BB 2TBD 1.0 BU/BN  
IP N\_HEV | PHEV HEATSTER

SC1247A 2TBD 1.0 BU/BN  
Body BEV HEATSTER

94/404:47

SC1247B 2TBD 1.0 BU/BN  
IP BEV HEATSTER

G1402BR 2TBD 1.0 BK/WH  
IP RHD HEATSTER

G1401AN 2TBD 1.0 BK/YE  
IP LHD HEATSTER

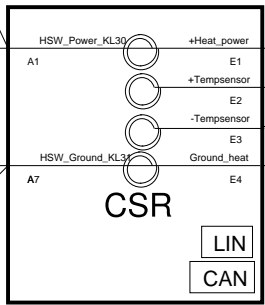

4/247 STEERING WHEEL MODULE SWM

S1247C 2TBD 0.75 BK  
Int\_Heated\_Steering\_wheel common HEATSTER

V5247A 2TBD 0.35 BK  
Int\_Heated\_Steering\_wheel common HEATSTER

R5247A 2TBD 0.35 BK  
Int\_Heated\_Steering\_wheel common HEATSTER

G6248A 2TBD 0.75 BK  
Int\_Heated\_Steering\_wheel common HEATSTER

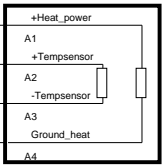

9/55 HEATED STEERING WHEEL

<p>The copying, distribution and utilization of this document as well as the communication of its contents to others without expressed authorization is prohibited. Offenders will be held liable for payment of damages. All rights reserved in the event of the grant of a patent, utility model or ornamental design registration.</p> <p><b>VOLVO</b> VOLVO CAR CORPORATION</p>	<b>Document title</b> CMA_622A_CC_All_5_30 5G_Steering_Wheel_Heating	
	<b>Document Type</b> DRAW/ELSY	<b>Release Status</b> RELEASED
	Volvo Document No 33445458	<b>Edited</b> May/26/2022
	<b>Issue</b> 030	<b>Page No</b> 108/149

# 6A Locking Front Right

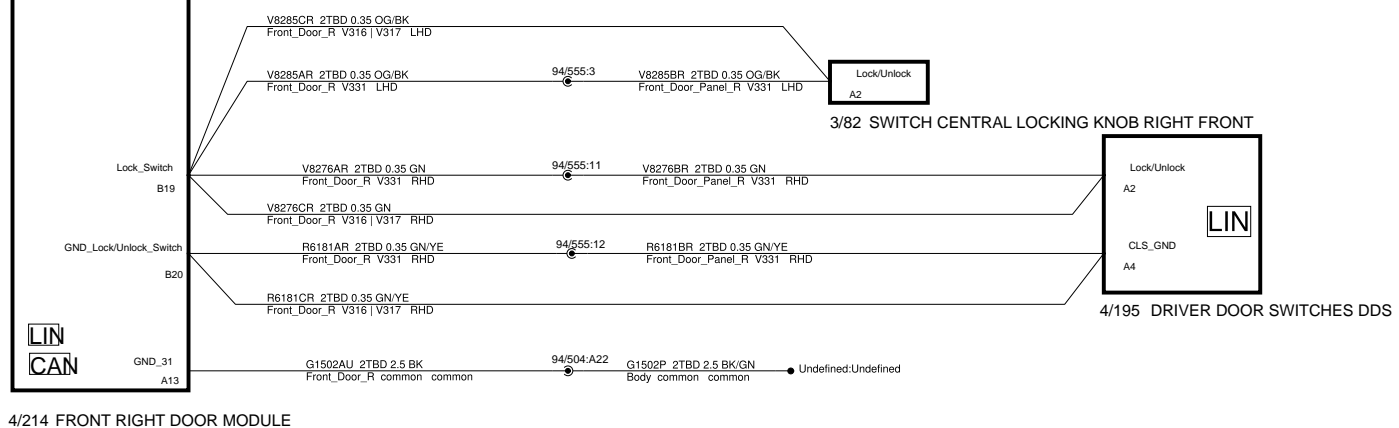
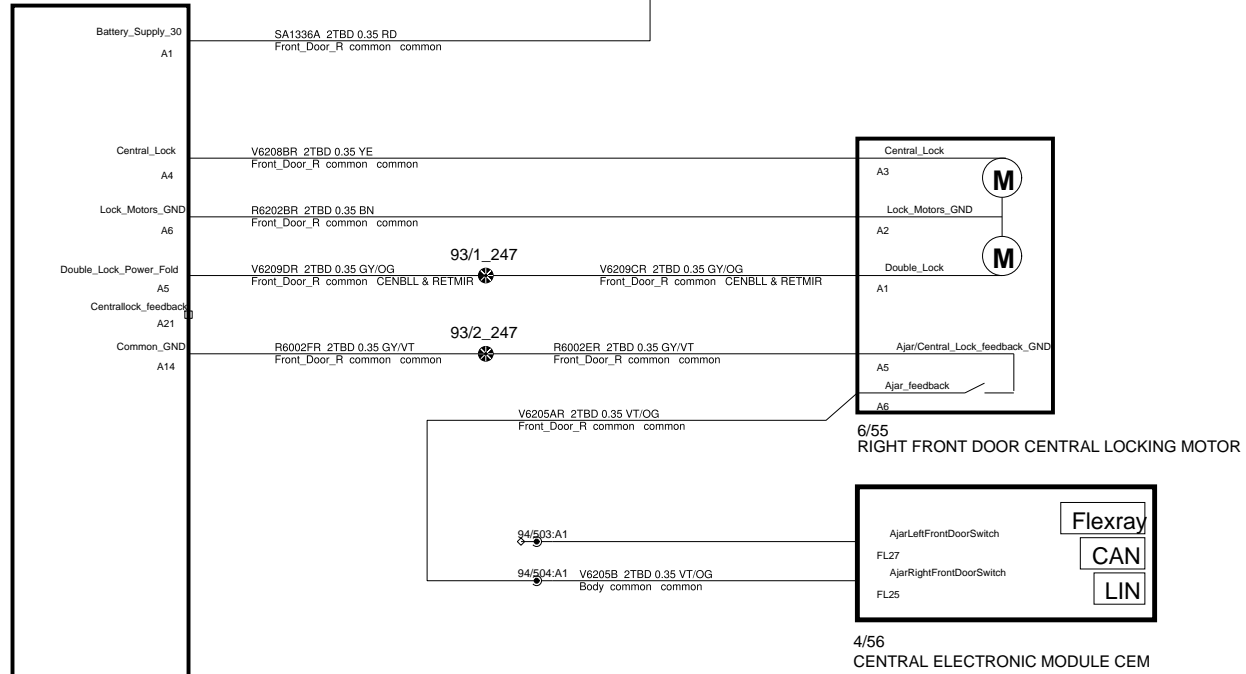
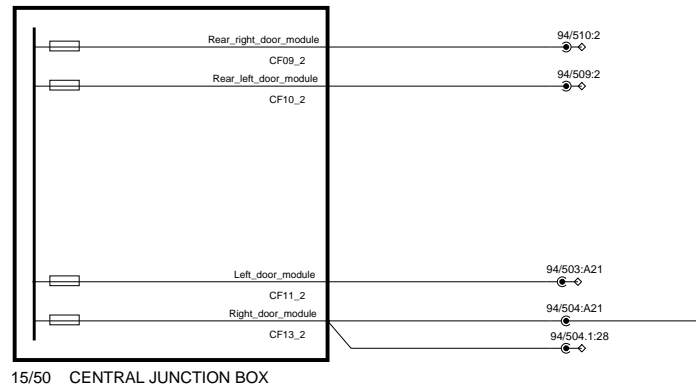

<b>VOLVO</b> VOLVO CAR CORPORATION	<b>Document title</b> CMA_622A_CC_All_5_30 6A_Locking_Front_Right	
	<b>Document Type</b> DRAW/ELSY	<b>Release Status</b> RELEASED
	CEVT Document No 8888522365	<b>Edited</b> March/02/2022
	<b>Issue</b> 030	<b>Page No</b> 110/149

# 6A Locking Rear Right

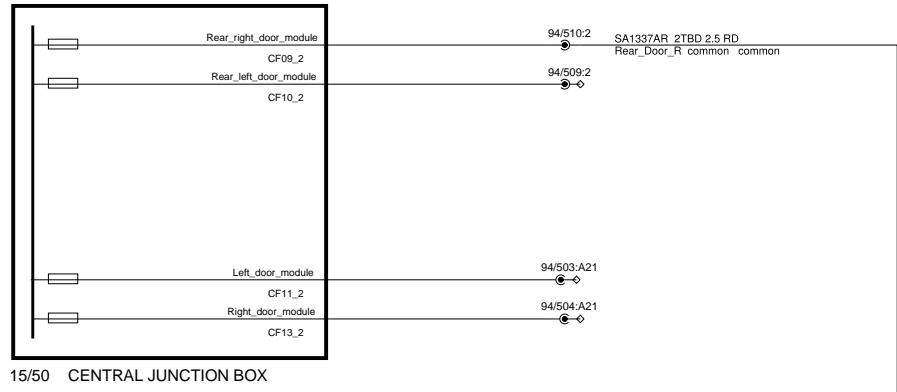

15/50 CENTRAL JUNCTION BOX

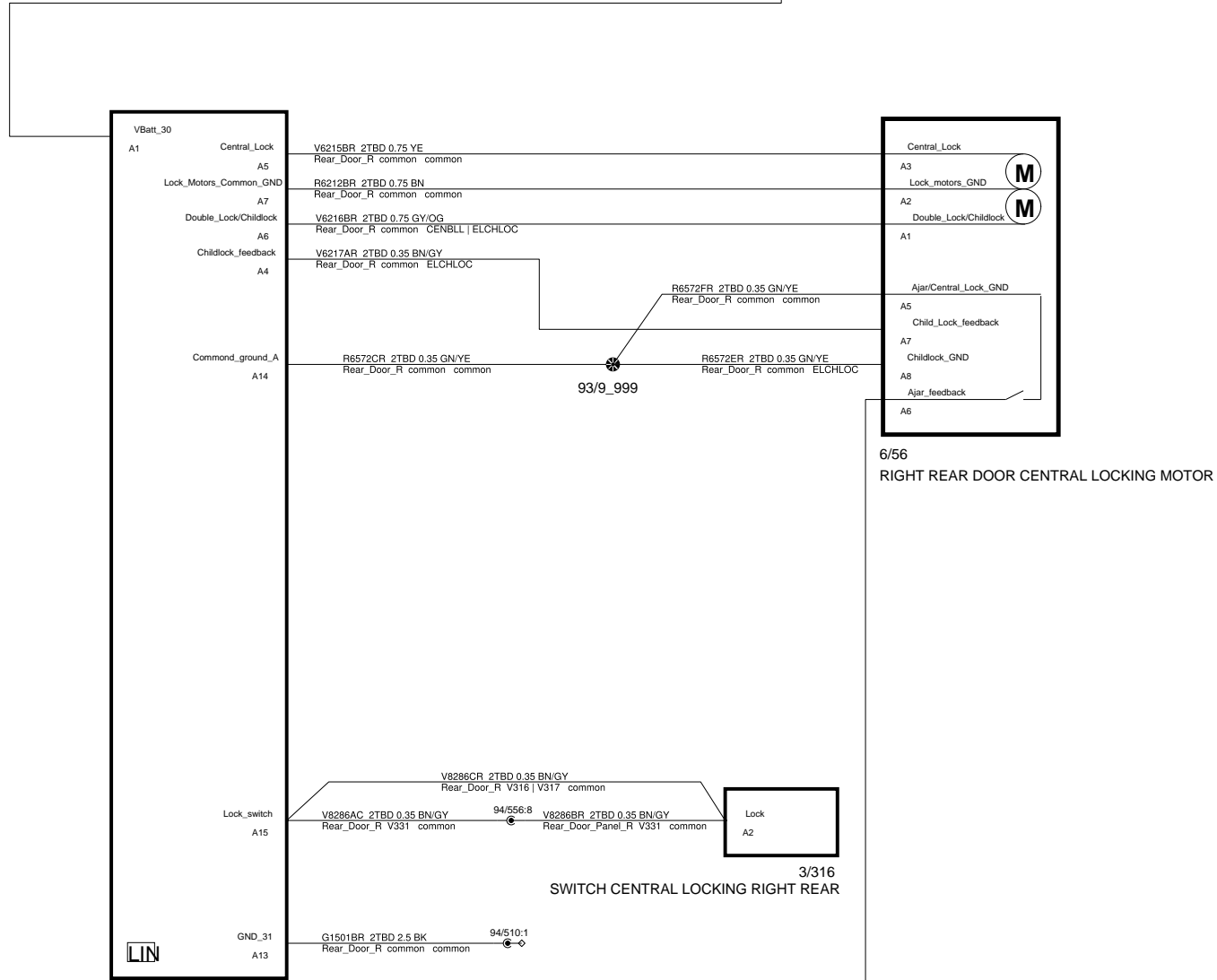

4/216 REAR RIGHT DOOR MODULE

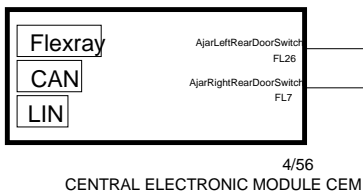

4/56 CENTRAL ELECTRONIC MODULE CEM

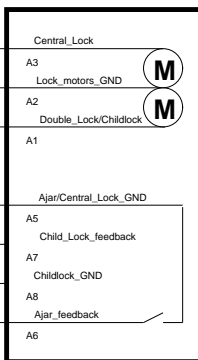

6/56 RIGHT REAR DOOR CENTRAL LOCKING MOTOR

3/316 SWITCH CENTRAL LOCKING RIGHT REAR

<p>The copying, distribution and utilization of this document as well as the communication of its contents to others without expressed authorization is prohibited. Offenders will be held liable for payment of damages. All rights reserved in the event of the grant of a patent, utility model or ornamental design registration.</p> <p><b>VOLVO</b> VOLVO CAR CORPORATION</p>	<b>Document title</b> CMA_622A_CC_All_5_30 6A_Locking_Rear_Right	
	<b>Document Type</b> DRAW/ELSY	<b>Release Status</b> RELEASED
	CEVT Document No 8888522365	<b>Edited</b> March/02/2022
	<b>Issue</b> 030	<b>Page No</b> 111/149

# 6A Locking

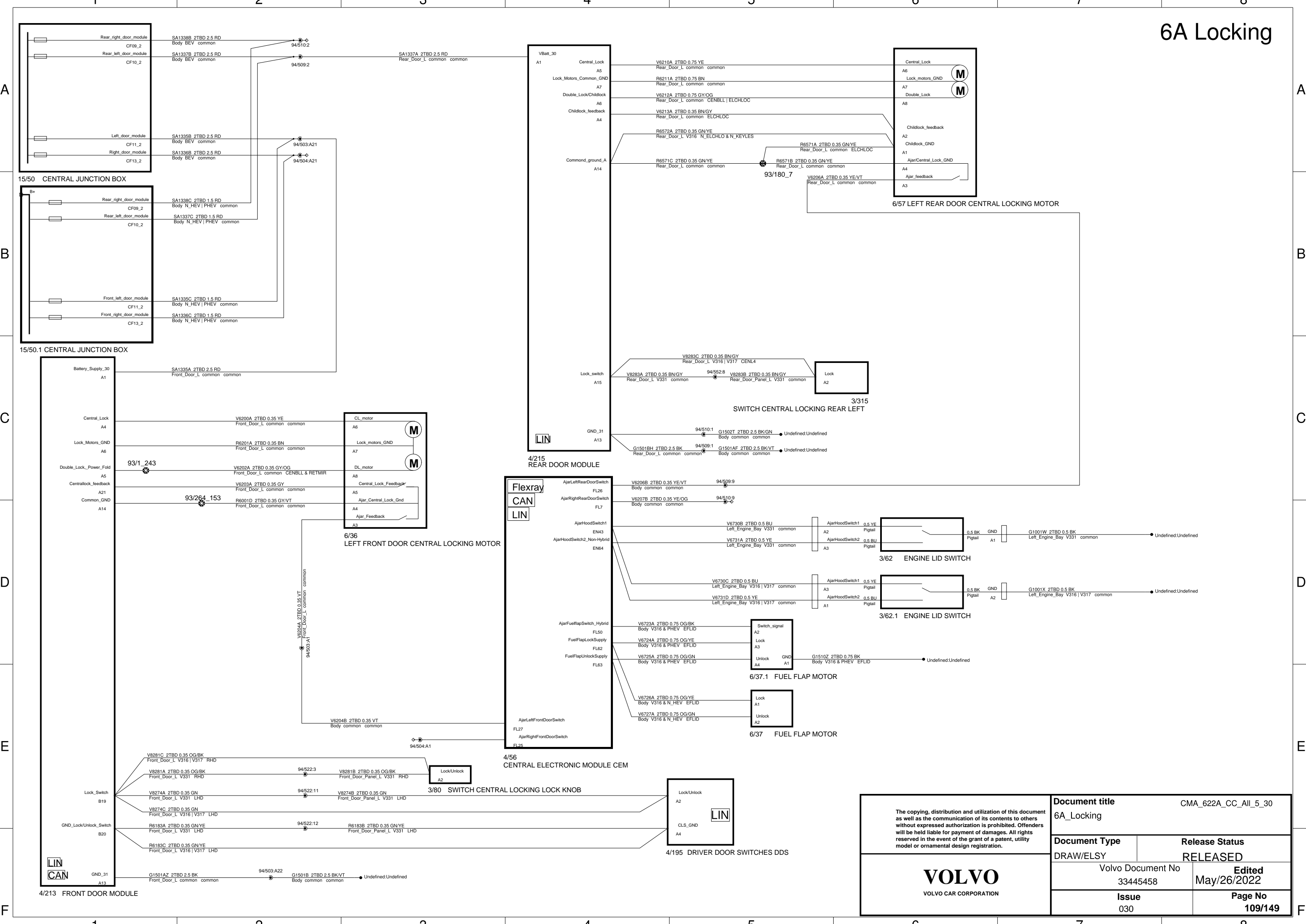

<p>The copying, distribution and utilization of this document as well as the communication of its contents to others without expressed authorization is prohibited. Offenders will be held liable for payment of damages. All rights reserved in the event of the grant of a patent, utility model or ornamental design registration.</p> <p><b>VOLVO</b> VOLVO CAR CORPORATION</p>		<b>Document title</b> CMA_622A_CC_All_5_30	
		6A_Locking	
<b>Document Type</b> DRAW/ELSY	<b>Release Status</b> RELEASED		
Volvo Document No 33445458		<b>Edited</b> May/26/2022	
<b>Issue</b> 030		<b>Page No</b> 109/149	



# 6C Theft Protection

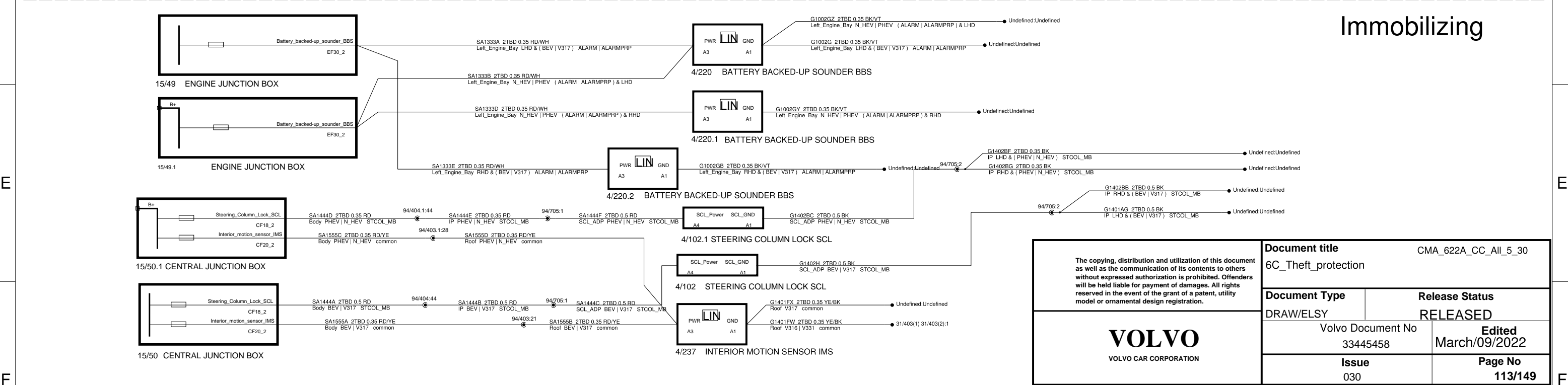
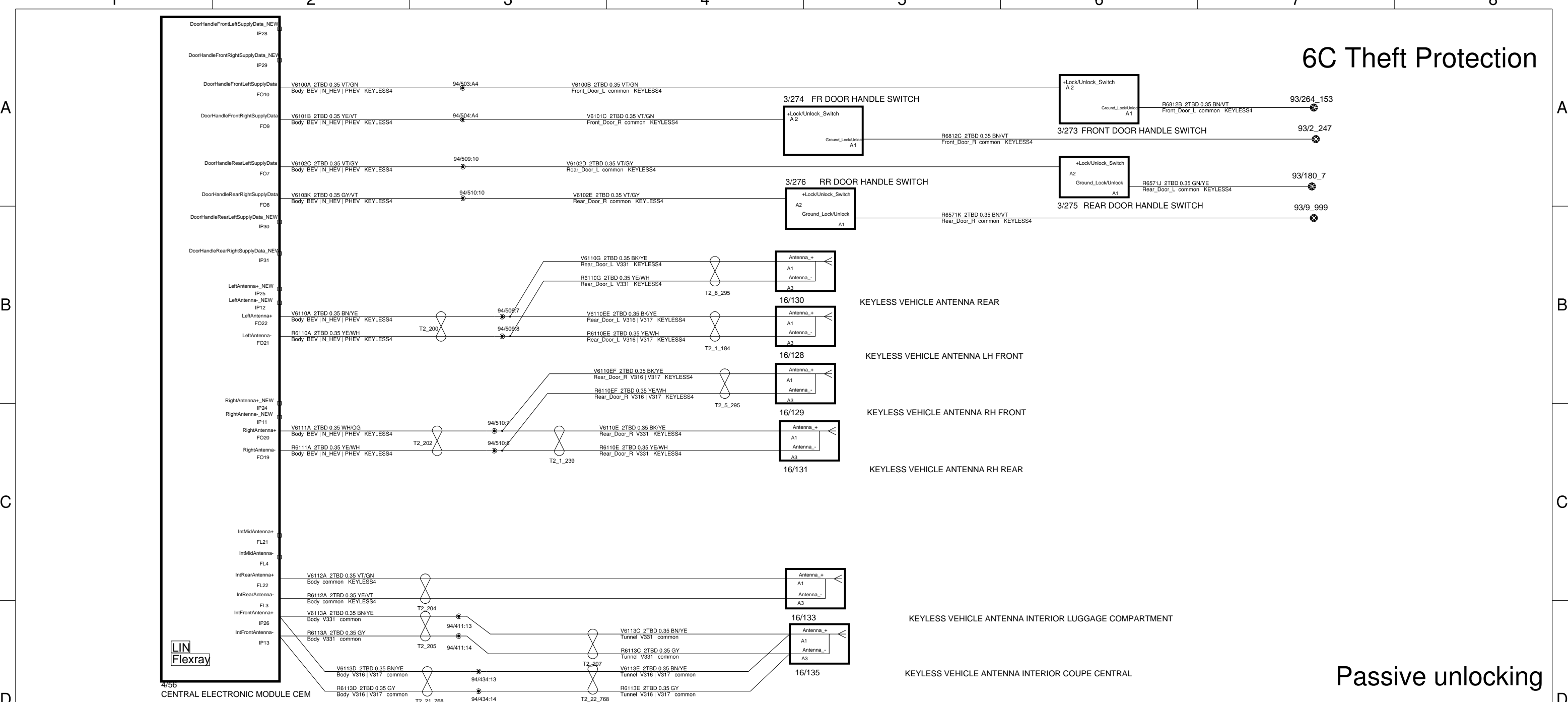

<p>The copying, distribution and utilization of this document as well as the communication of its contents to others without expressed authorization is prohibited. Offenders will be held liable for payment of damages. All rights reserved in the event of the grant of a patent, utility model or ornamental design registration.</p> <p><b>VOLVO</b> VOLVO CAR CORPORATION</p>		<b>Document title</b> CMA_622A_CC_All_5_30	
		<b>6C_Theft_protection</b>	
<b>Document Type</b> DRAW/ELSY		<b>Release Status</b> RELEASED	
Volvo Document No 33445458		<b>Edited</b> March/09/2022	
<b>Issue</b> 030		<b>Page No</b> 113/149	

# 6C1 Phone As Key

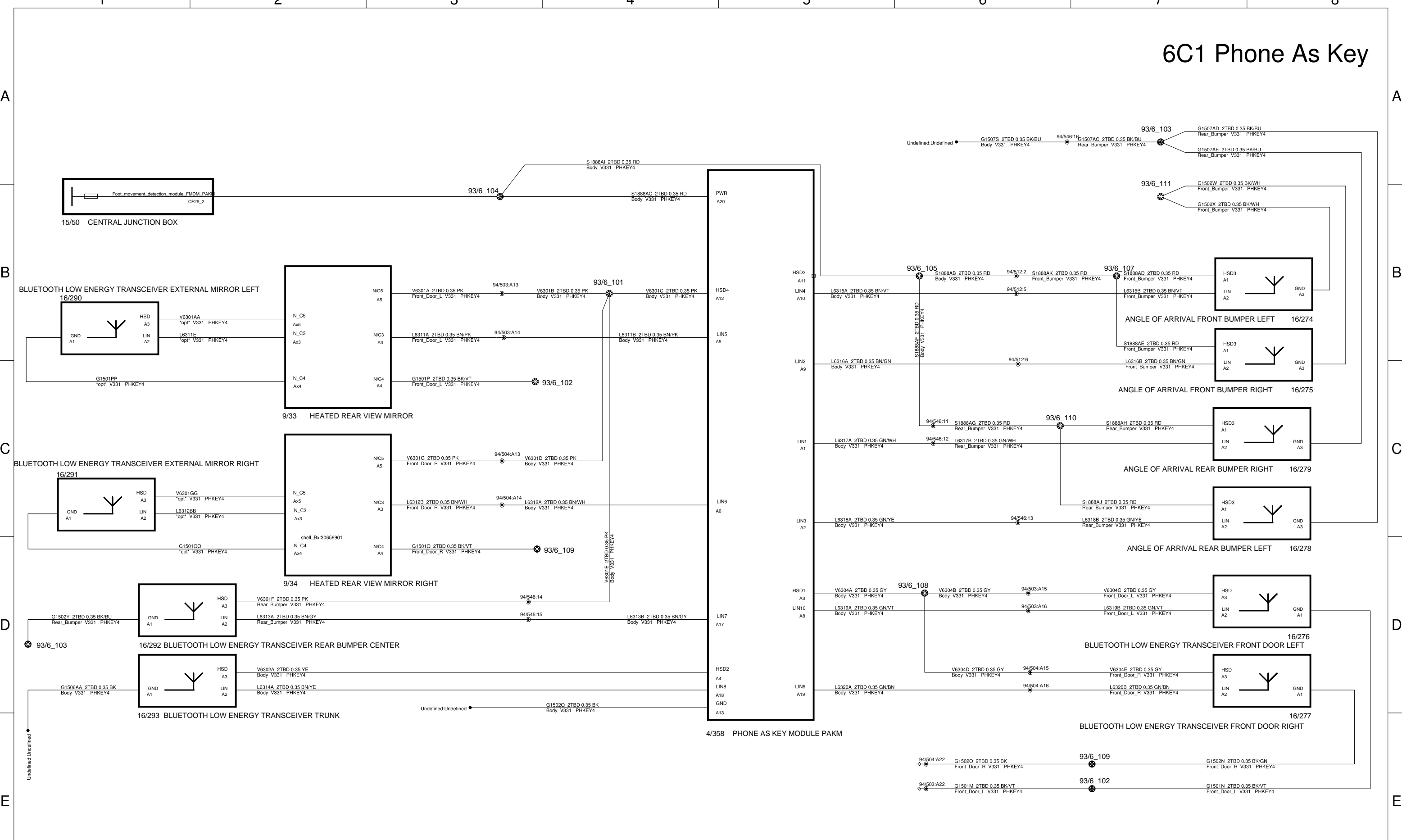



# 6D Window manoeuvring Right 6E Mirror manoeuvring Right

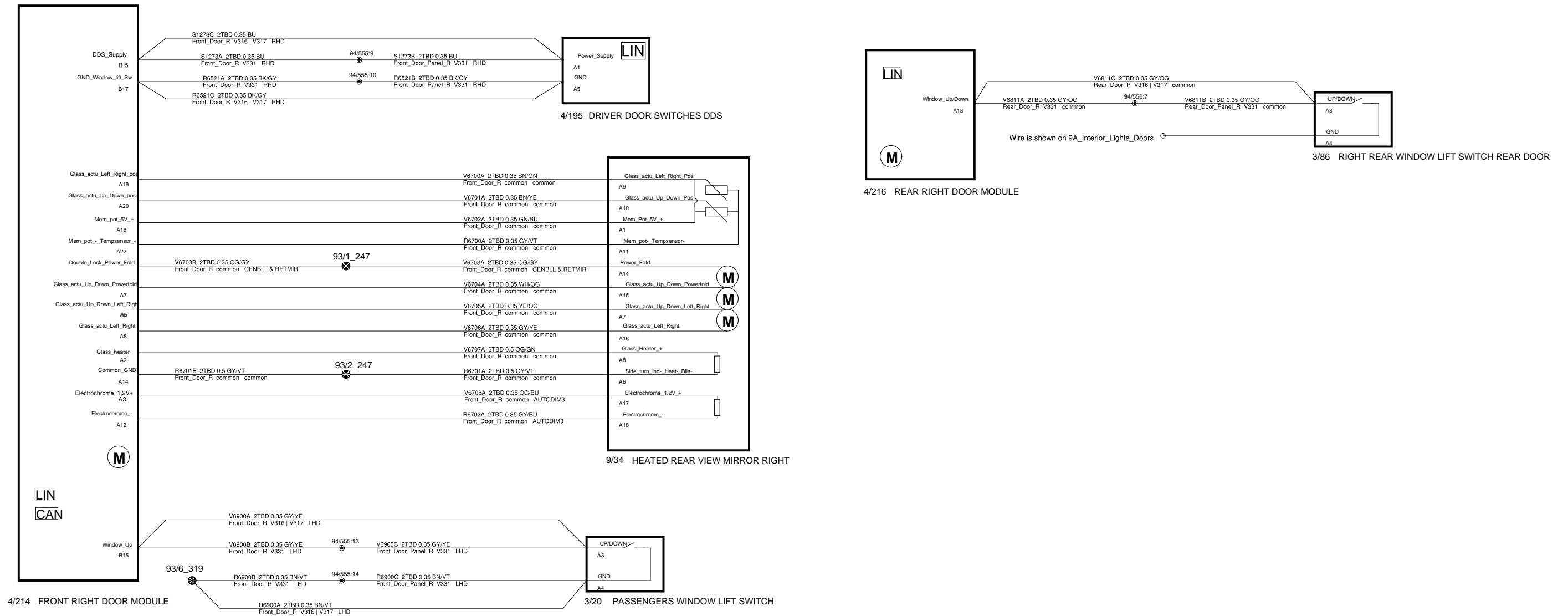

<p>The copying, distribution and utilization of this document as well as the communication of its contents to others without expressed authorization is prohibited. Offenders will be held liable for payment of damages. All rights reserved in the event of the grant of a patent, utility model or ornamental design registration.</p> <p><b>VOLVO</b> VOLVO CAR CORPORATION</p>	<b>Document title</b> CMA_622A_CC_A11_5_30 6D_Window_Manoevring_Right	
	<b>Document Type</b> DRAW/ELSY	<b>Release Status</b> RELEASED
	CEVT Document No 8888522365	<b>Edited</b> February/28/2022
	<b>Issue</b> 030	<b>Page No</b> 115/149

# 6F Roof Manoeuvring

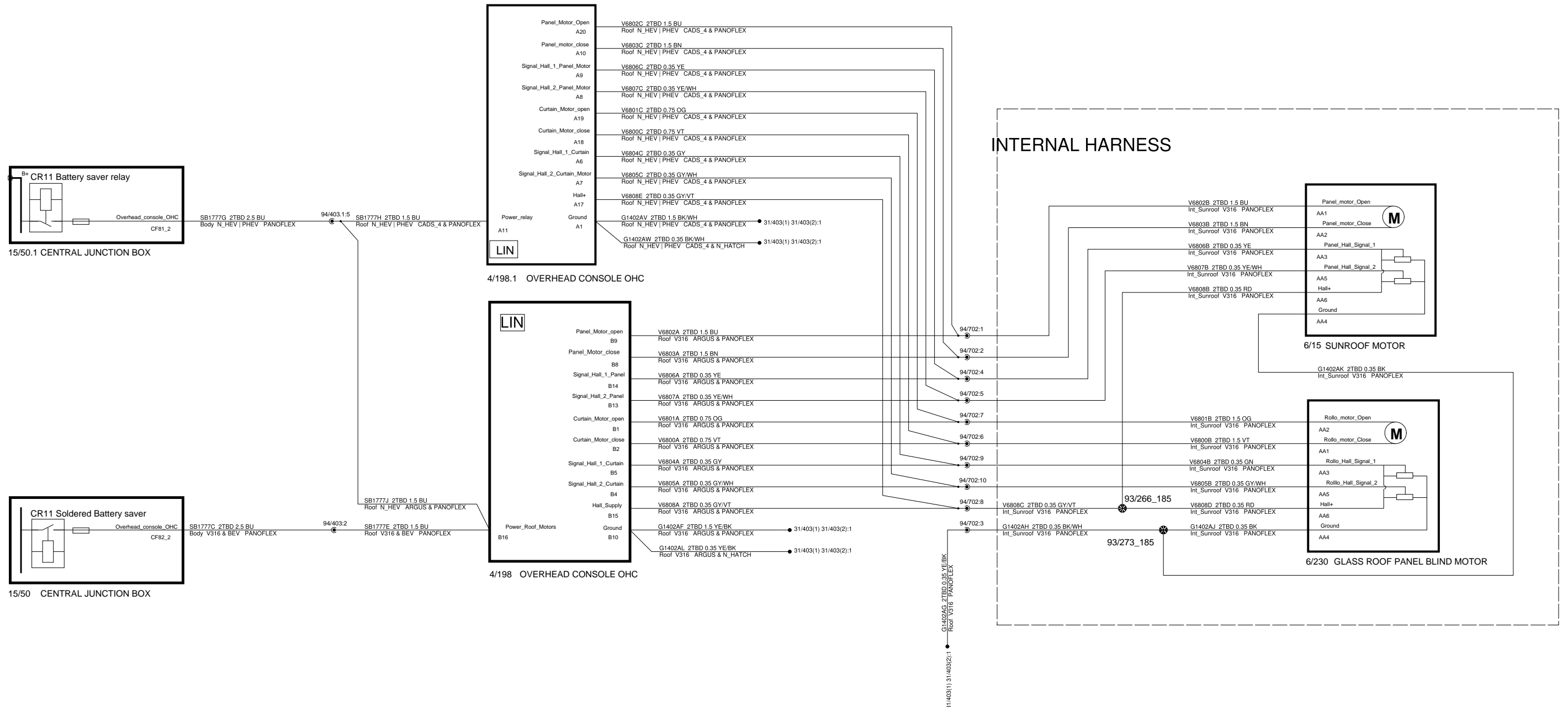

<p>The copying, distribution and utilization of this document as well as the communication of its contents to others without expressed authorization is prohibited. Offenders will be held liable for payment of damages. All rights reserved in the event of the grant of a patent, utility model or ornamental design registration.</p> <p><b>VOLVO</b> VOLVO CAR CORPORATION</p>	<b>Document title</b> CMA_622A_CC_All_5_30 6F_Roof_Manoeuvring	
	<b>Document Type</b> DRAW/ELSY	<b>Release Status</b> RELEASED
	CEVT Document No 8888522365	<b>Edited</b> June/16/2021
	<b>Issue</b> 030	<b>Page No</b> 116/149

# 6K Tailgate & Boot Lid Manoeuvring 6N Luggage Concealing

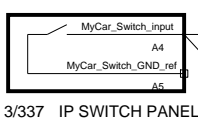
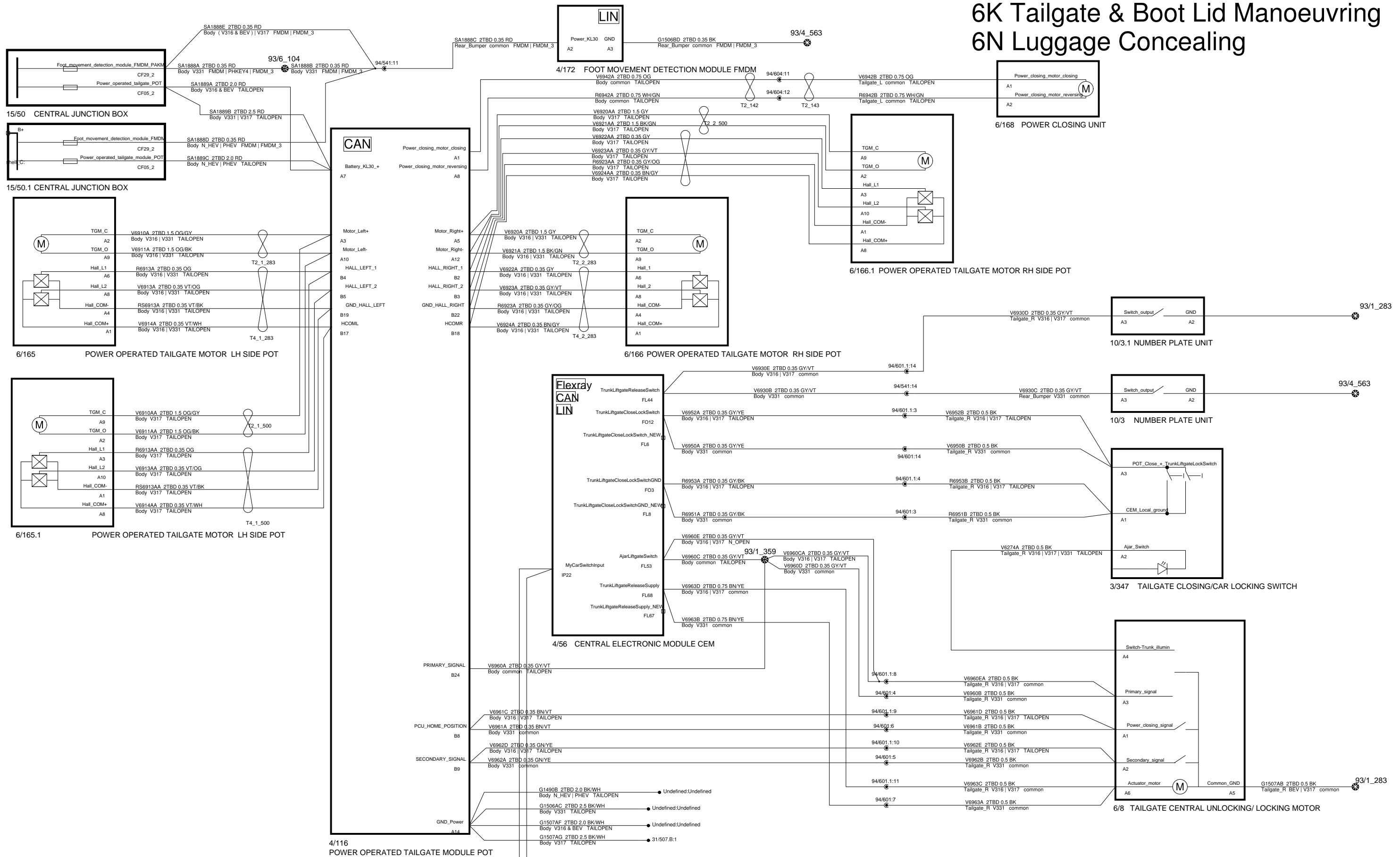

The copying, distribution and utilization of this document as well as the communication of its contents to others without expressed authorization is prohibited. Offenders will be held liable for payment of damages. All rights reserved in the event of the grant of a patent, utility model or ornamental design registration.



<b>Document title</b>		CMA_622A_CC_All_5_30 6K_Tailgate_and_boot_lid_manoeuvring_etc	
<b>Document Type</b>	<b>Release Status</b>		
DRAW/ELSY	RELEASED		
Volvo Document No 33445458		<b>Edited</b> March/17/2022	
<b>Issue</b> 030	<b>Page No</b> 117/149		

# 6P Voltage Outlet

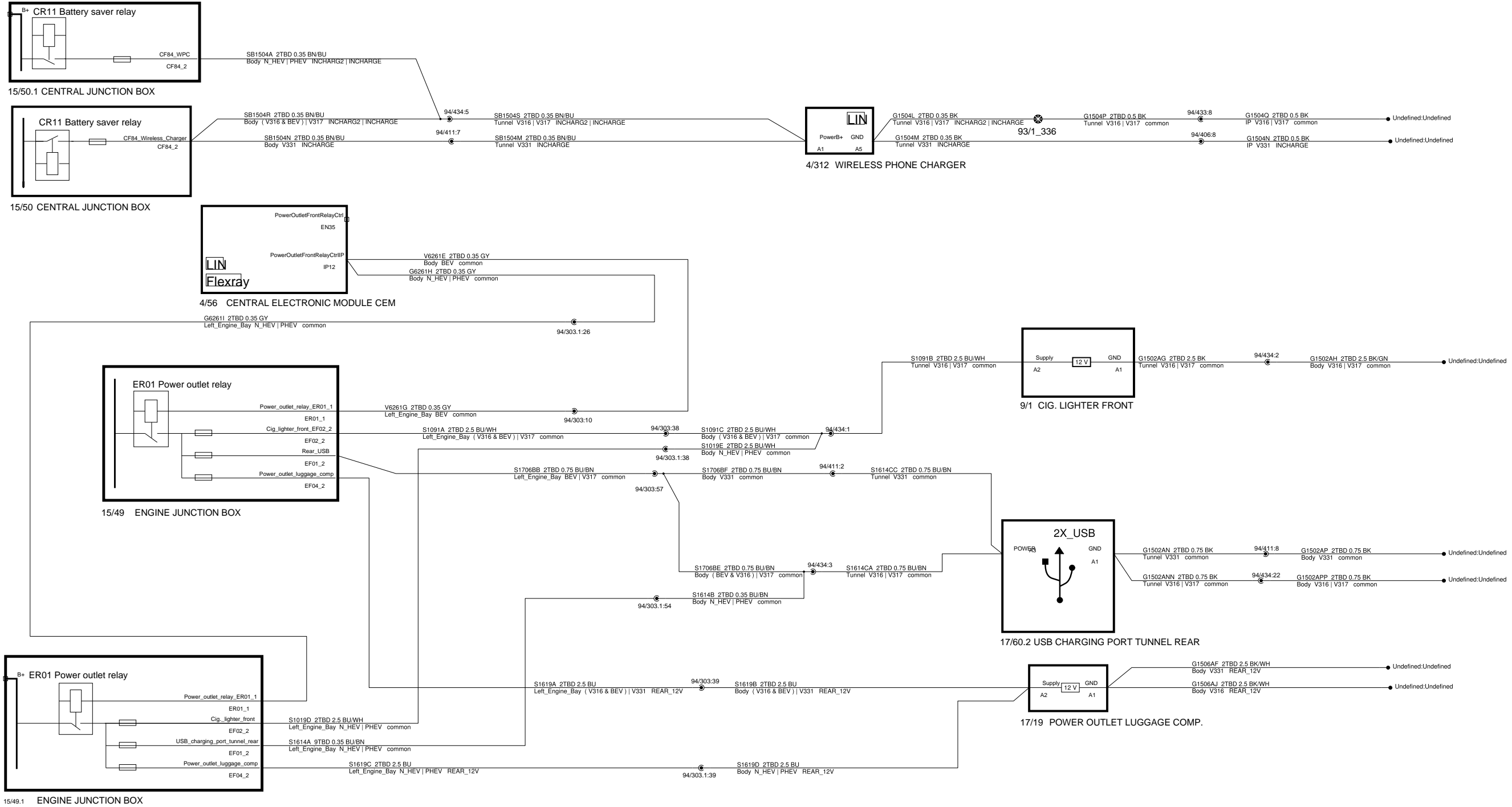

<p>The copying, distribution and utilization of this document as well as the communication of its contents to others without expressed authorization is prohibited. Offenders will be held liable for payment of damages. All rights reserved in the event of the grant of a patent, utility model or ornamental design registration.</p> <p><b>VOLVO</b> VOLVO CAR CORPORATION</p>	<b>Document title</b> CMA_622A_CC_All_5_30	
	6P_Voltage_outlet	
	<b>Document Type</b> DRAW/ELSY	<b>Release Status</b> RELEASED
	Volvo Document No 33445458	<b>Edited</b> February/18/2022
<b>Issue</b> 030	<b>Page No</b> 118/149	

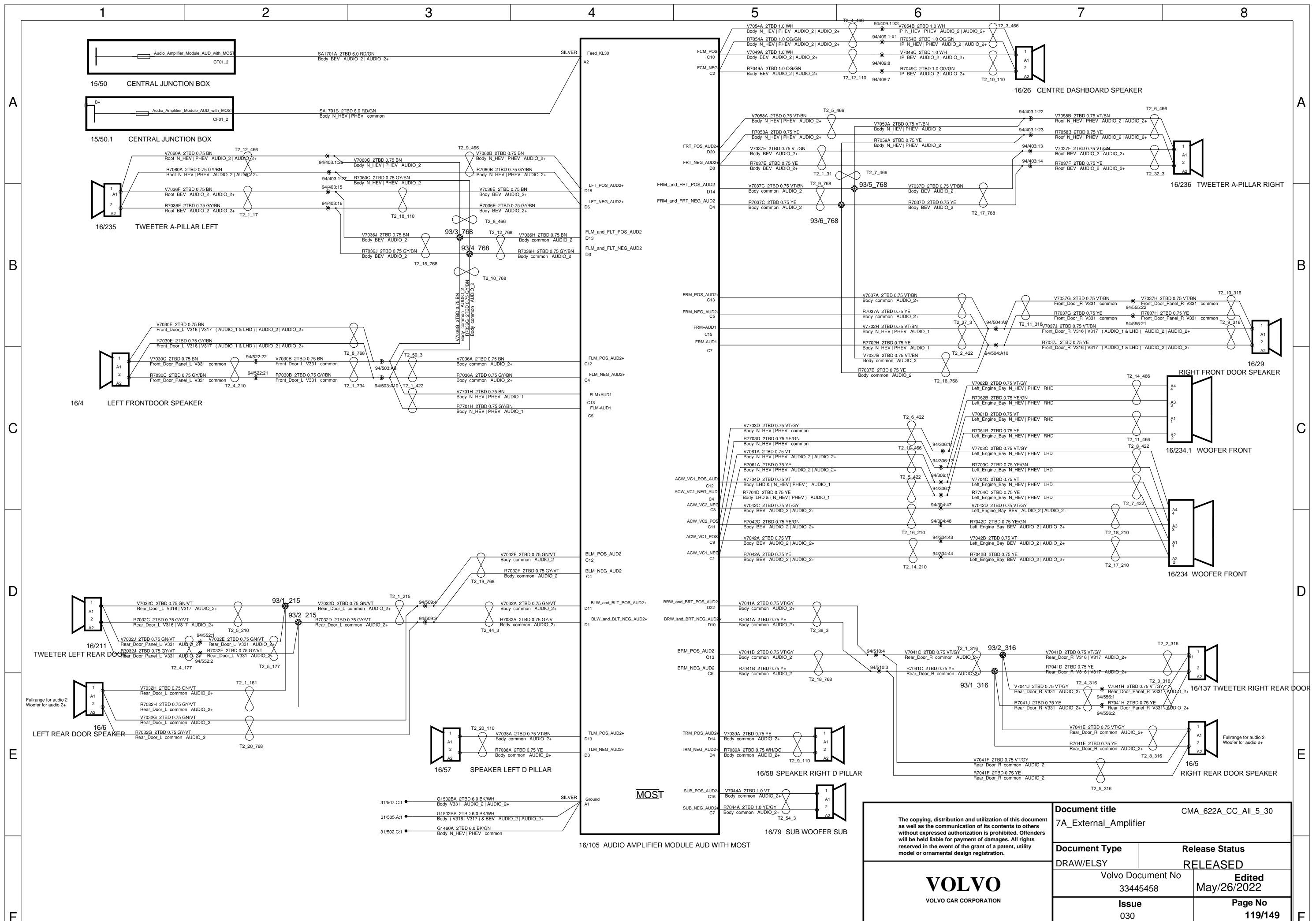



# 7A Infotainment IHU 3.0/N\_iCUP

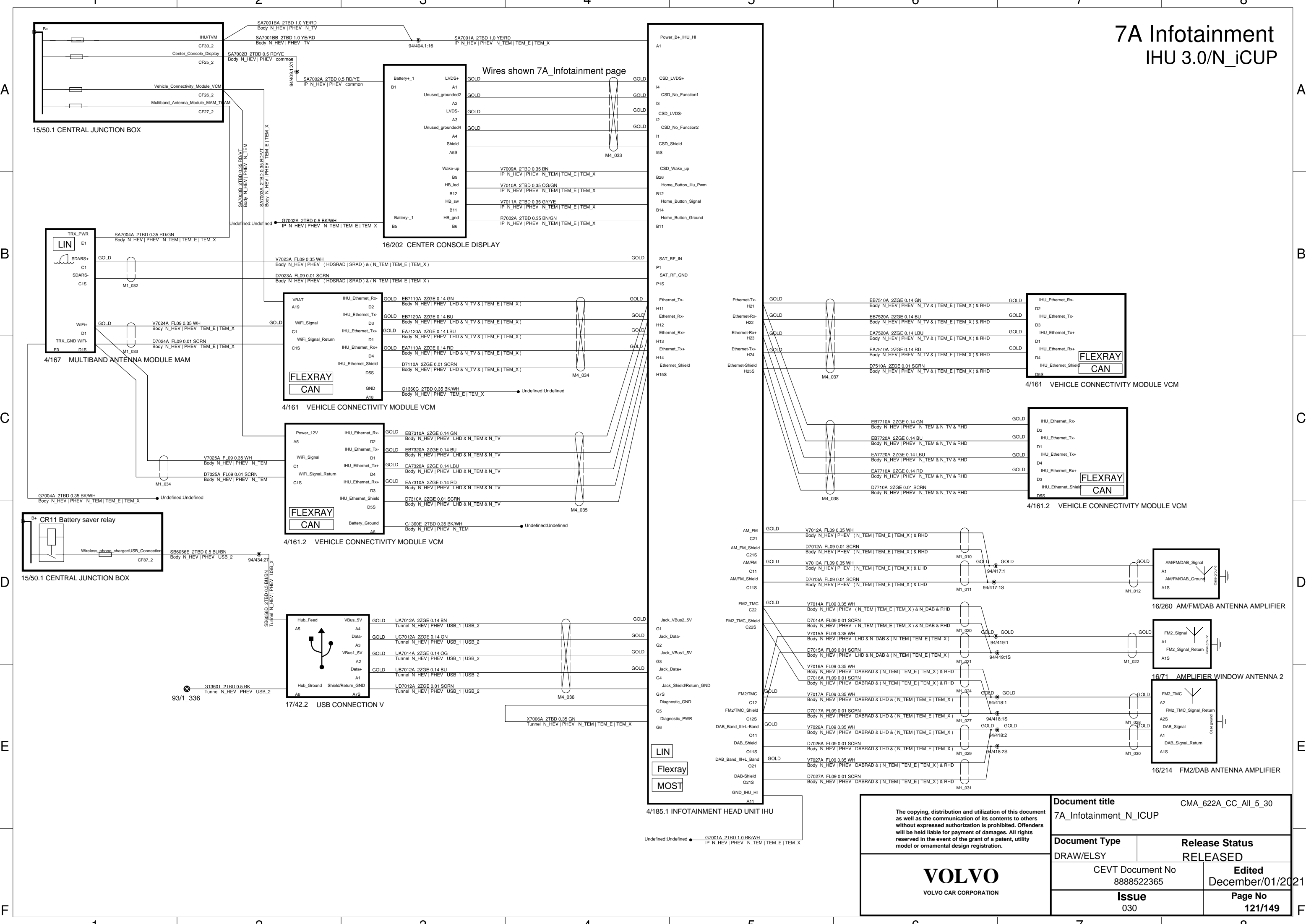

The copying, distribution and utilization of this document as well as the communication of its contents to others without expressed authorization is prohibited. Offenders will be held liable for payment of damages. All rights reserved in the event of the grant of a patent, utility model or ornamental design registration.		<b>Document title</b> 7A_Infotainment_N_ICUP CMA_622A_CC_All_5_30	
<b>Document Type</b> DRAW/ELSY		<b>Release Status</b> RELEASED	
CEVT Document No 8888522365		<b>Edited</b> December/01/2021	
<b>Issue</b> 030		<b>Page No</b> 121/149	



Undefined:Undefined ● G7001A 2TBD 1.0 BK/WH IP\_N\_HEV|PHEV\_N\_TEM|TEM\_E|TEM\_X

4/185.1 INFOTAINMENT HEAD UNIT IHU

LIN  
Flexray  
MOST

Jack\_VBus2\_5V  
G1  
Jack\_Data-  
G2  
Jack\_VBus1\_5V  
G3  
Jack\_Data+  
G4  
Jack\_Shield/Return\_GND  
G7S  
Diagnostic\_GND  
G5  
Diagnostic\_PWR  
G6

Power\_12V  
A5  
WIFI\_Signal  
C1  
WIFI\_Signal\_Return  
D4  
C1S  
IHU\_Ethernet\_Rx+  
D3  
IHU\_Ethernet\_Shield  
D5S  
Battery\_Ground  
A6

VBAT  
A19  
IHU\_Ethernet\_Rx-  
D2  
IHU\_Ethernet\_Tx-  
D3  
WIFI\_Signal  
C1  
IHU\_Ethernet\_Tx+  
D1  
WIFI\_Signal\_Return  
D4  
C1S  
IHU\_Ethernet\_Rx+  
D1  
IHU\_Ethernet\_Shield  
D5S  
GND  
A18

SAT\_RF\_IN  
P1  
SAT\_RF\_GND  
P1S

Power\_B+\_IHU\_HI  
A1  
CSD\_LVDS+  
I4  
CSD\_No\_Function1  
I3  
CSD\_LVDS-  
I2  
CSD\_No\_Function2  
I2  
CSD\_Shield  
I5S  
CSD\_Wake\_up  
B26  
Home\_Button\_Illu\_Pwm  
B12  
Home\_Button\_Signal  
B14  
Home\_Button\_Ground  
B11

Wires shown 7A\_Infotainment page

Battery+_1 B1	LVDS+ A1	GOLD	GOLD
Unused_grounded2	A2	GOLD	GOLD
LVDS- A3	A3	GOLD	GOLD
Unused_grounded4	A4	GOLD	GOLD
Shield A4	A4		
A5S	A5		
Wake-up B9	V7009A 2TBD 0.35 BN IP_N_HEV PHEV_N_TEM TEM_E TEM_X		
HB_led B12	V7010A 2TBD 0.35 OG/GN IP_N_HEV PHEV_N_TEM TEM_E TEM_X		
HB_sw B11	V7011A 2TBD 0.35 GY/YE IP_N_HEV PHEV_N_TEM TEM_E TEM_X		
HB_gnd B6	R7002A 2TBD 0.35 BN/GN IP_N_HEV PHEV_N_TEM TEM_E TEM_X		

16/202 CENTER CONSOLE DISPLAY

EB7110A 2ZGE 0.14 GN Body_N_HEV PHEV_LHD & N_TV & (TEM_E TEM_X)	GOLD	GOLD
EB7120A 2ZGE 0.14 BU Body_N_HEV PHEV_LHD & N_TV & (TEM_E TEM_X)	GOLD	GOLD
EA7120A 2ZGE 0.14 LBU Body_N_HEV PHEV_LHD & N_TV & (TEM_E TEM_X)	GOLD	GOLD
EA7110A 2ZGE 0.14 RD Body_N_HEV PHEV_LHD & N_TV & (TEM_E TEM_X)	GOLD	GOLD
D7110A 2ZGE 0.01 SCR/N Body_N_HEV PHEV_LHD & N_TV & (TEM_E TEM_X)		
G1360C 2TBD 0.35 BK/WH Body_N_HEV PHEV_TEM_E TEM_X		

EB7310A 2ZGE 0.14 GN Body_N_HEV PHEV_LHD & N_TEM & N_TV	GOLD	GOLD
EB7320A 2ZGE 0.14 BU Body_N_HEV PHEV_LHD & N_TEM & N_TV	GOLD	GOLD
EA7320A 2ZGE 0.14 LBU Body_N_HEV PHEV_LHD & N_TEM & N_TV	GOLD	GOLD
EA7310A 2ZGE 0.14 RD Body_N_HEV PHEV_LHD & N_TEM & N_TV	GOLD	GOLD
D7310A 2ZGE 0.01 SCR/N Body_N_HEV PHEV_LHD & N_TEM & N_TV		
G1360E 2TBD 0.35 BK/WH Body_N_HEV PHEV_N_TEM		

4/161.2 VEHICLE CONNECTIVITY MODULE VCM

UA7012A 2ZGE 0.14 BN Tunnel_N_HEV PHEV_USB_1 USB_2	GOLD	GOLD
UC7012A 2ZGE 0.14 GN Tunnel_N_HEV PHEV_USB_1 USB_2	GOLD	GOLD
UA7014A 2ZGE 0.14 OG Tunnel_N_HEV PHEV_USB_1 USB_2	GOLD	GOLD
UB7012A 2ZGE 0.14 BU Tunnel_N_HEV PHEV_USB_1 USB_2	GOLD	GOLD
UD7012A 2ZGE 0.01 SCR/N Tunnel_N_HEV PHEV_USB_1 USB_2		

17/42.2 USB CONNECTION V

X7006A 2TBD 0.35 GN  
Tunnel\_N\_HEV|PHEV\_N\_TEM|TEM\_E|TEM\_X

G1360T 2TBD 0.5 BK  
Tunnel\_N\_HEV|PHEV\_USB\_2

93/1\_336

Hub\_Feed  
A5  
VBus\_5V  
A4  
Data-  
A3  
VBus1\_5V  
A2  
Data+  
A1  
Hub\_Ground  
A6  
Shield/Return\_GND  
A7S

Power\_12V  
A5  
WIFI\_Signal  
C1  
WIFI\_Signal\_Return  
D4  
C1S  
IHU\_Ethernet\_Rx+  
D3  
IHU\_Ethernet\_Shield  
D5S  
Battery\_Ground  
A6

VBAT  
A19  
IHU\_Ethernet\_Rx-  
D2  
IHU\_Ethernet\_Tx-  
D3  
WIFI\_Signal  
C1  
IHU\_Ethernet\_Tx+  
D1  
WIFI\_Signal\_Return  
D4  
C1S  
IHU\_Ethernet\_Rx+  
D1  
IHU\_Ethernet\_Shield  
D5S  
GND  
A18

SAT\_RF\_IN  
P1  
SAT\_RF\_GND  
P1S

Power\_B+\_IHU\_HI  
A1  
CSD\_LVDS+  
I4  
CSD\_No\_Function1  
I3  
CSD\_LVDS-  
I2  
CSD\_No\_Function2  
I2  
CSD\_Shield  
I5S  
CSD\_Wake\_up  
B26  
Home\_Button\_Illu\_Pwm  
B12  
Home\_Button\_Signal  
B14  
Home\_Button\_Ground  
B11

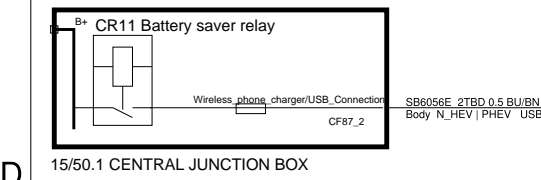
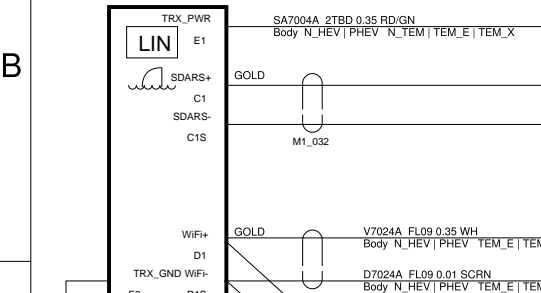
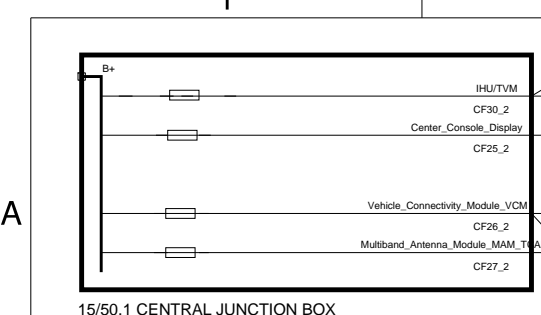

# 7A Infotainment IHU 4.0/iCUP

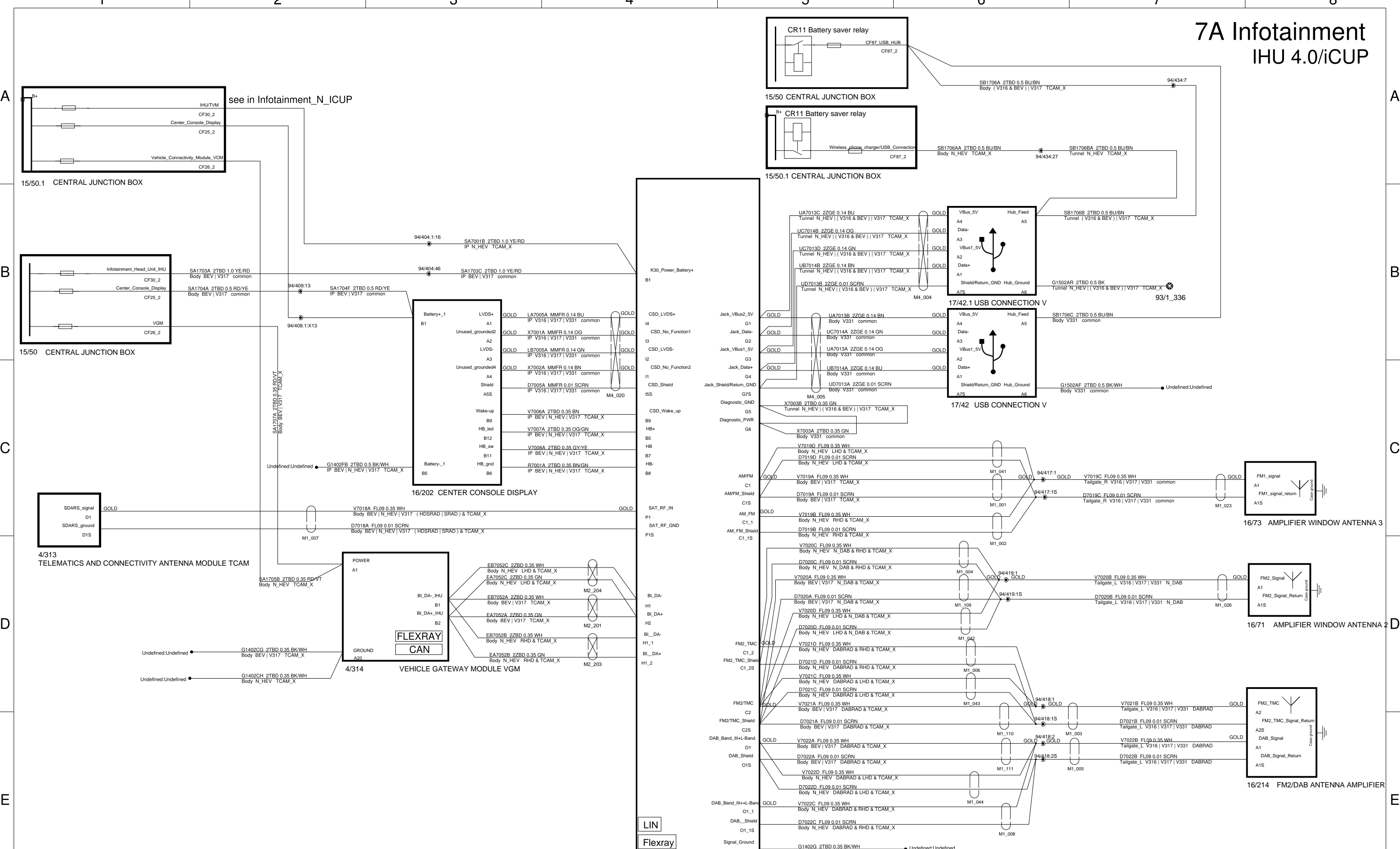

LIN  
 Flexray  
 MOST  
 4/185 INFOTAINMENT HEAD UNIT IHU

<p>The copying, distribution and utilization of this document as well as the communication of its contents to others without expressed authorization is prohibited. Offenders will be held liable for payment of damages. All rights reserved in the event of the grant of a patent, utility model or ornamental design registration.</p>		<p><b>Document title</b> 7A_Infotainment</p>		<p>CMA_622A_CC_All_5_30</p>	
<p><b>Document Type</b> DRAW/ELSY</p>		<p><b>Release Status</b> RELEASED</p>		<p><b>Edited</b> September/16/202</p>	
<p><b>Issue</b> 030</p>		<p>Volvo Document No 33445458</p>		<p><b>Page No</b> 120/149</p>	



# 7A Television

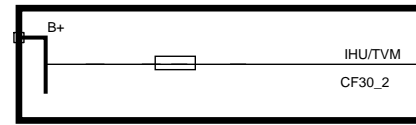

15/50.1 CENTRAL JUNCTION BOX

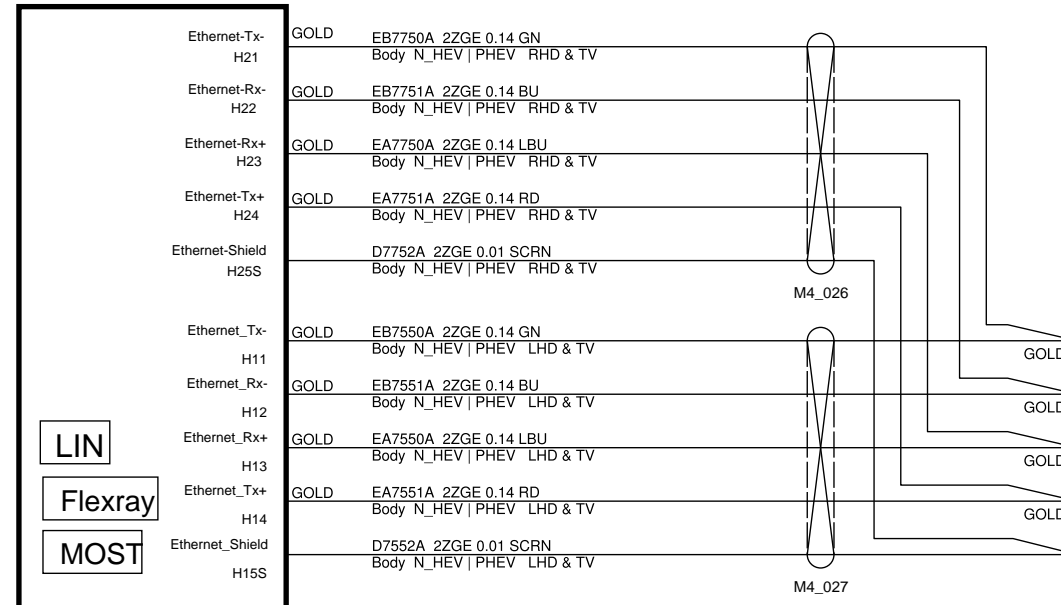

4/185.1 INFOTAINMENT HEAD UNIT IHU

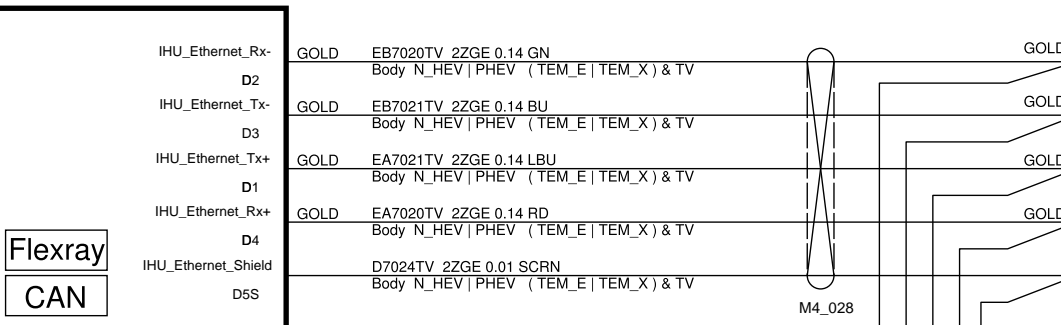

4/161 VEHICLE CONNECTIVITY MODULE VCM

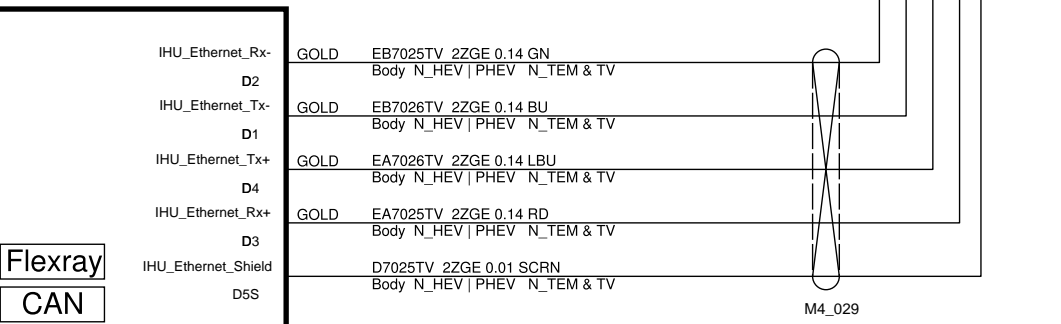

4/161.2 VEHICLE CONNECTIVITY MODULE VCM

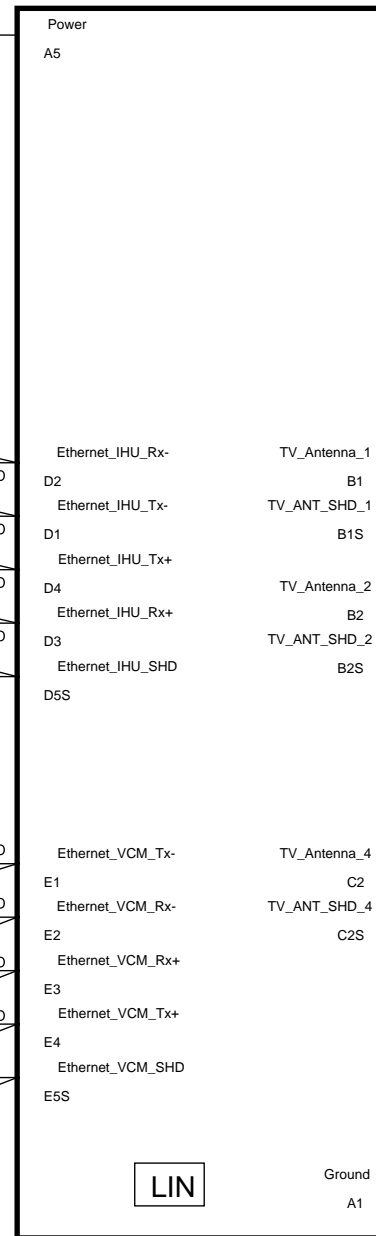

4/248 TELEVISION MODULE TVM

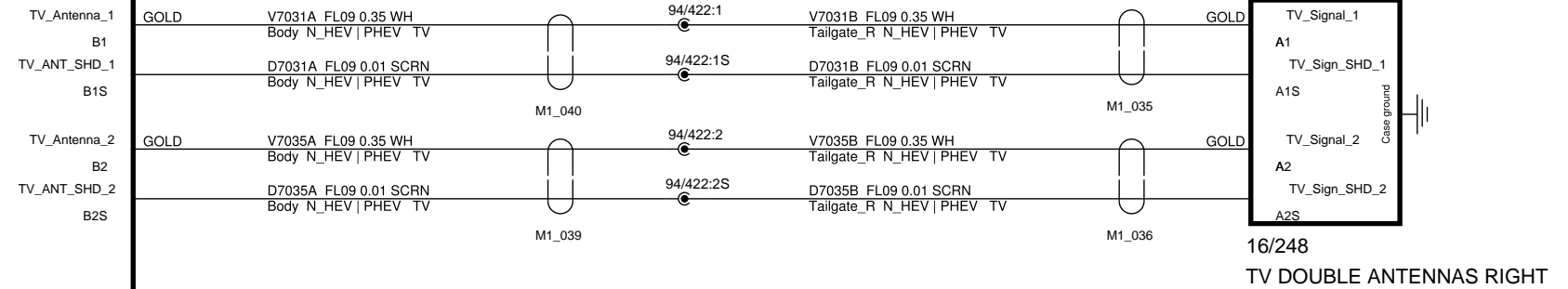

16/248 TV DOUBLE ANTENNAS RIGHT

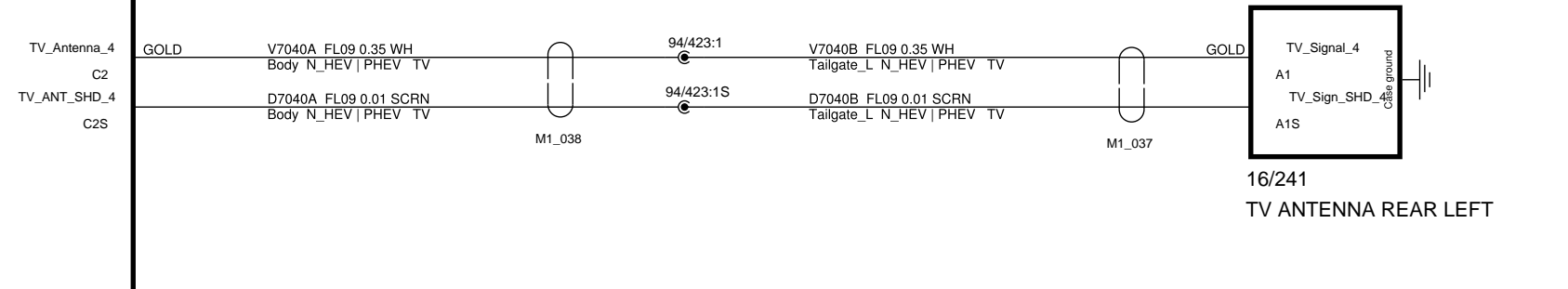

16/241 TV ANTENNA REAR LEFT



<p>The copying, distribution and utilization of this document as well as the communication of its contents to others without expressed authorization is prohibited. Offenders will be held liable for payment of damages. All rights reserved in the event of the grant of a patent, utility model or ornamental design registration.</p> <p><b>VOLVO</b> VOLVO CAR CORPORATION</p>	<p><b>Document title</b> CMA_622A_CC_All_5_30</p> <p>7A_Television</p>	
	<p><b>Document Type</b></p> <p>DRAW/ELSY</p>	<p><b>Release Status</b></p> <p>RELEASED</p>
	<p>CEVT Document No</p> <p>8888522365</p>	<p><b>Edited</b></p> <p>June/16/2021</p>
	<p><b>Issue</b></p> <p>030</p>	<p><b>Page No</b></p> <p>122/149</p>

# 7B Telematics

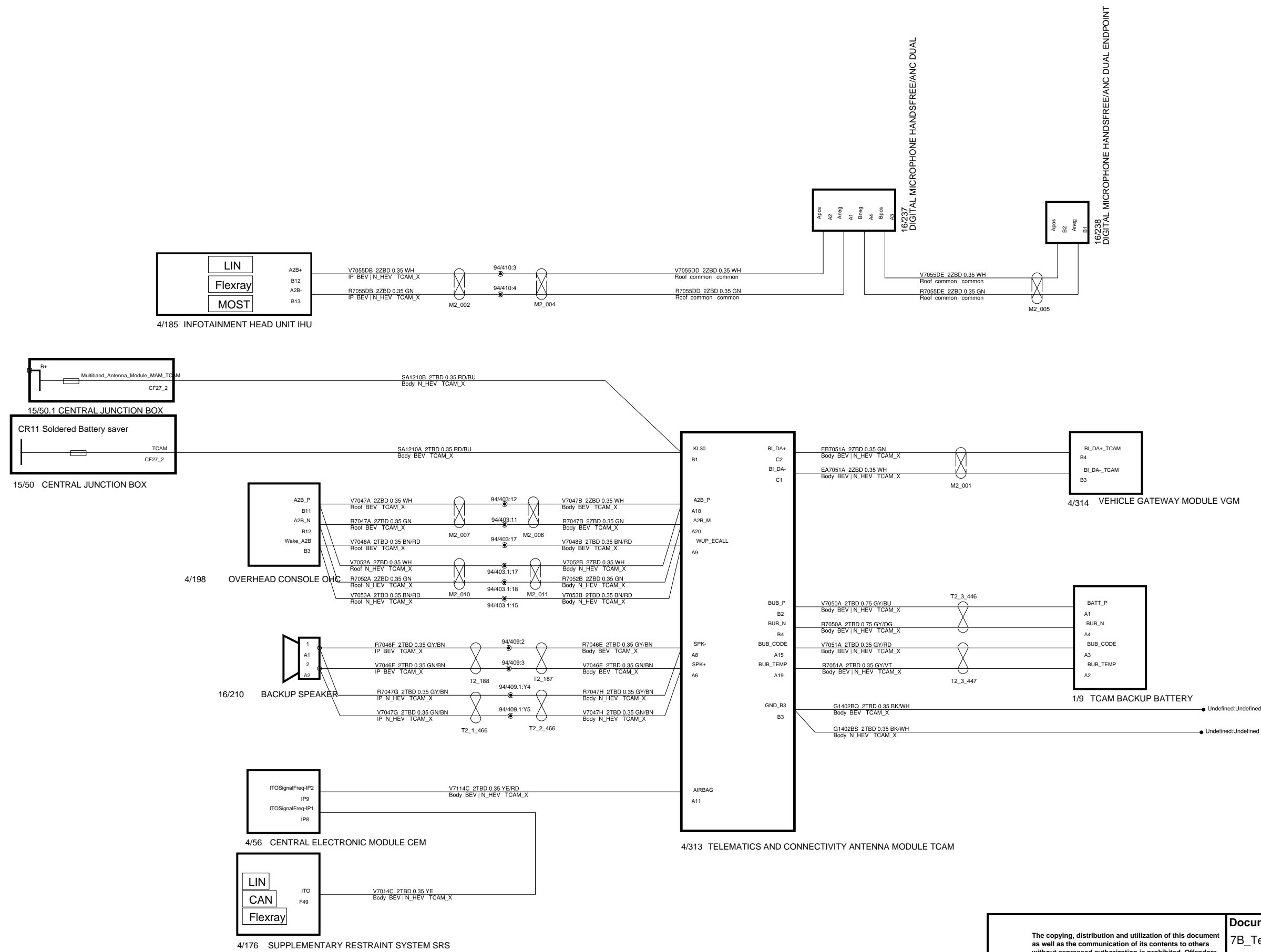

<p>The copying, distribution and utilization of this document as well as the communication of its contents to others without expressed authorization is prohibited. Offenders will be held liable for payment of damages. All rights reserved in the event of the grant of a patent, utility model or ornamental design registration.</p> <p><b>VOLVO</b> VOLVO CAR CORPORATION</p>	<b>Document title</b> CMA_622A_CC_All_5_30	
	7B_Telematics_ICUP	
	<b>Document Type</b> DRAW/ELSY	<b>Release Status</b> RELEASED
	Volvo Document No 33445458	<b>Edited</b> February/18/2022
<b>Issue</b> 030	<b>Page No</b> 123/149	

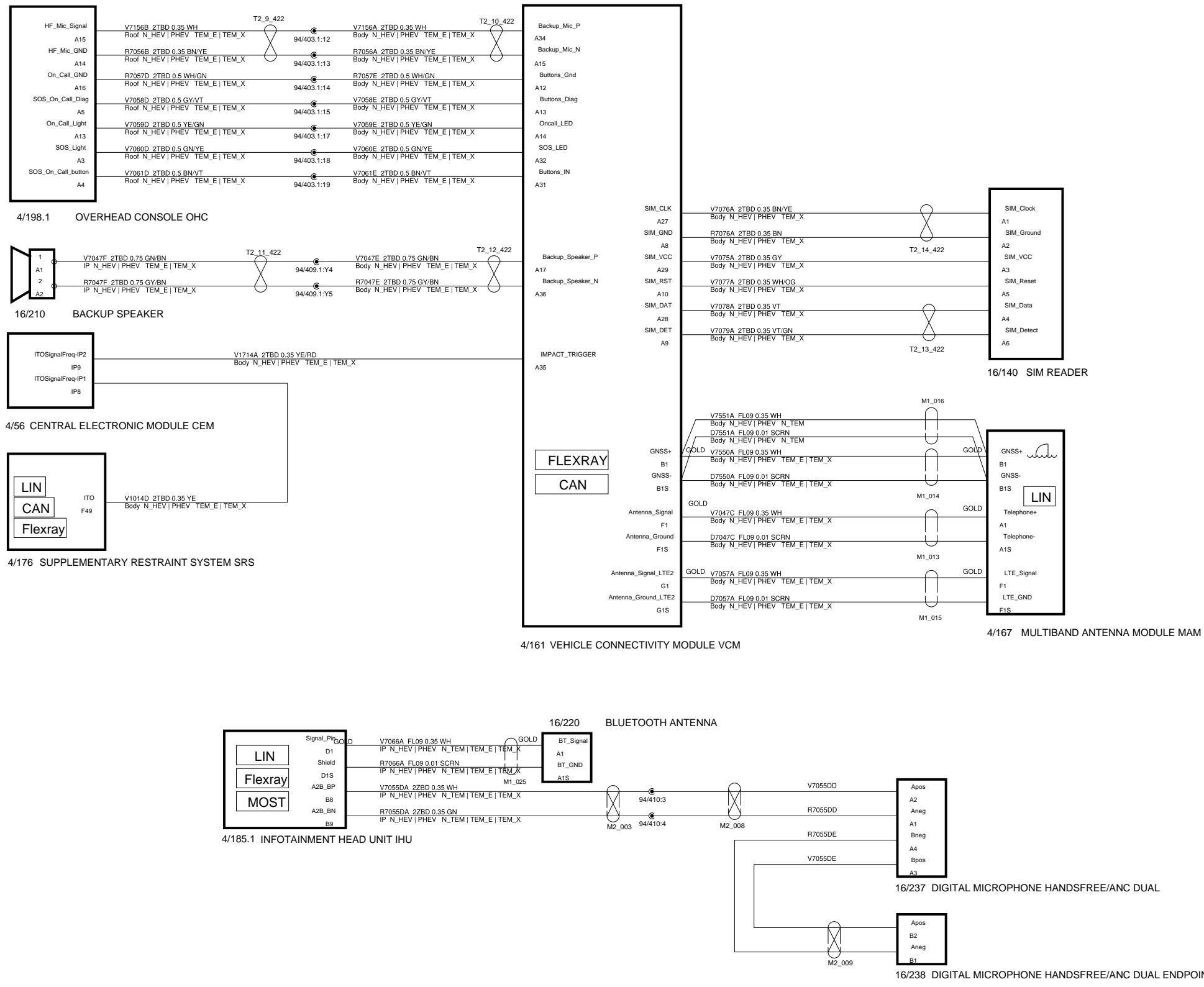

<p>The copying, distribution and utilization of this document as well as the communication of its contents to others without expressed authorization is prohibited. Offenders will be held liable for payment of damages. All rights reserved in the event of the grant of a patent, utility model or ornamental design registration.</p> <p><b>VOLVO</b> VOLVO CAR CORPORATION</p>	<b>Document title</b> CMA_622A_CC_All_5_30	
	7B_Telematics_N_ICUP	
	<b>Document Type</b> DRAW/ELSY	<b>Release Status</b> RELEASED
	CEVT Document No 8888522365	<b>Edited</b> March/09/2022
<b>Issue</b> 030	<b>Page No</b> 124/149	

# 7C DSRC IHU 3.0/\_NiCUP

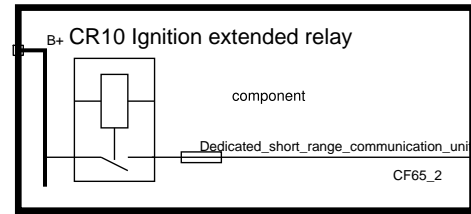

15/50.1 CENTRAL JUNCTION BOX

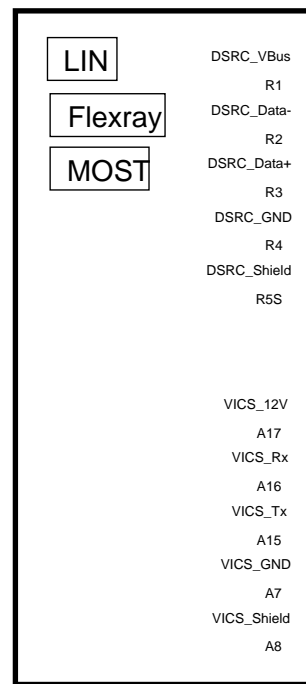
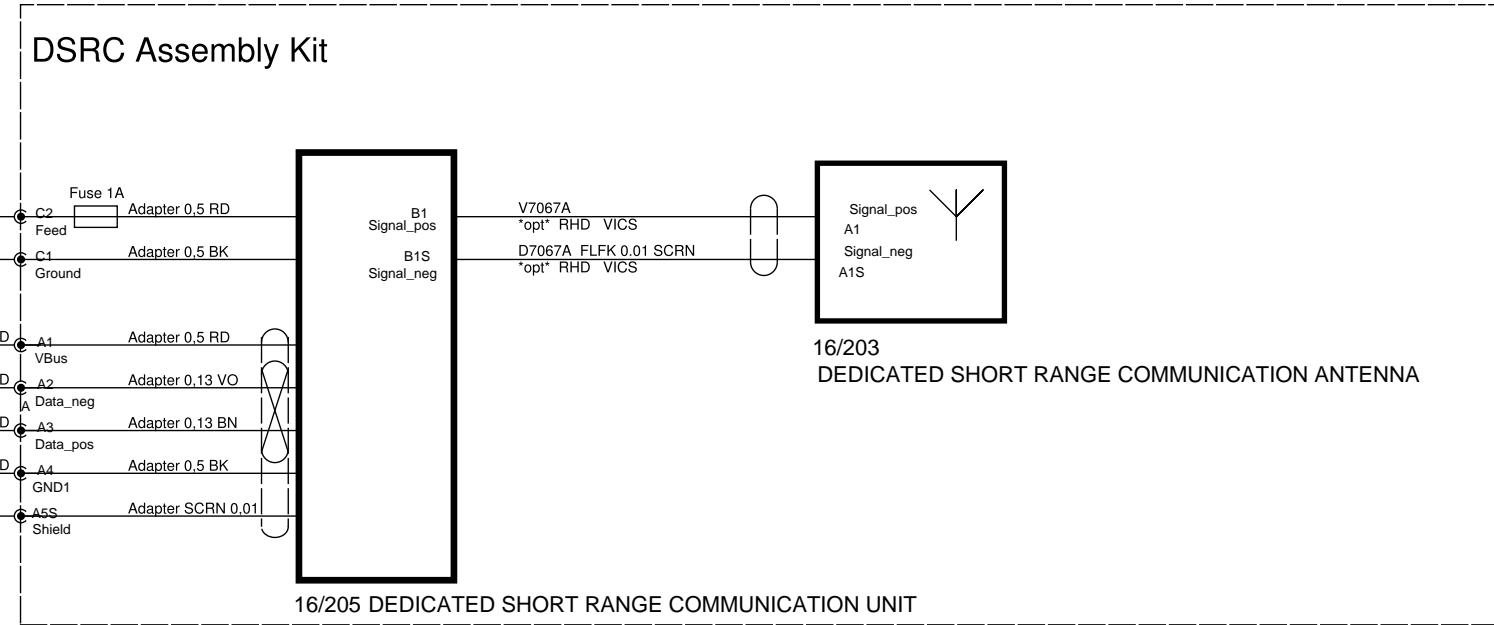

DSRC_VBus R1	GOLD	V7062A FLFK 0.09 WH IP_N_HEV PHEV (N_TEM TEM_E TEM_X) & VICS	GOLD	A1	Adapter 0.5 RD
DSRC_Data- R2	GOLD	R7063A FLFK 0.09 RD IP_N_HEV PHEV (N_TEM TEM_E TEM_X) & VICS	GOLD	A2	Adapter 0.13 VO
DSRC_Data+ R3	GOLD	V7063A FLFK 0.09 GN IP_N_HEV PHEV (N_TEM TEM_E TEM_X) & VICS	GOLD	A3	Adapter 0.13 BN
DSRC_GND R4	GOLD	R7062A FLFK 0.09 BK IP_N_HEV PHEV (N_TEM TEM_E TEM_X) & VICS	GOLD	A4	Adapter 0.5 BK
DSRC_Shield R5S		D7062A FLFK 0.01 SCRNL IP_N_HEV PHEV (N_TEM TEM_E TEM_X) & VICS		A5S	Adapter SCRNL 0.01
VICS_12V A17		V7064A F2AK 0.22 GN IP_N_HEV PHEV (N_TEM TEM_E TEM_X) & VICS		Feed_12V	Pigtail RD 0.14
VICS_Rx A16		V7065A F2AK 0.22 WH IP_N_HEV PHEV (N_TEM TEM_E TEM_X) & VICS		Signal_Tx	Pigtail BK 0.14
VICS_Tx A15		R7065A F2AK 0.22 YE IP_N_HEV PHEV (N_TEM TEM_E TEM_X) & VICS		Signal_Rx	Pigtail OG 0.14
VICS_GND A7		R7064A F2AK 0.22 BN IP_N_HEV PHEV (N_TEM TEM_E TEM_X) & VICS		Ground	Pigtail GN 0.14
VICS_Shield A8		D7064A F2AK 0.01 SCRNL IP_N_HEV PHEV (N_TEM TEM_E TEM_X) & VICS		Shield	Pigtail SCRNL 0.01

The copying, distribution and utilization of this document as well as the communication of its contents to others without expressed authorization is prohibited. Offenders will be held liable for payment of damages. All rights reserved in the event of the grant of a patent, utility model or ornamental design registration.

**VOLVO**  
VOLVO CAR CORPORATION

<b>Document title</b> 7C_DSRC_N_iCUP		CMA_622A_CC_All_5_30	
<b>Document Type</b> DRAW/ELSY	<b>Release Status</b> RELEASED		
CEVT Document No 8888522365		<b>Edited</b> May/26/2022	
<b>Issue</b> 030		<b>Page No</b> 126/149	

# 7C DSRC IHU 4.0/iCUP

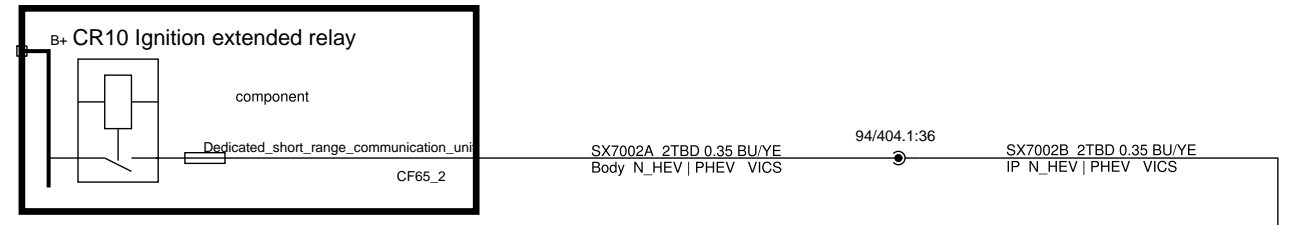

15/50.1 CENTRAL JUNCTION BOX

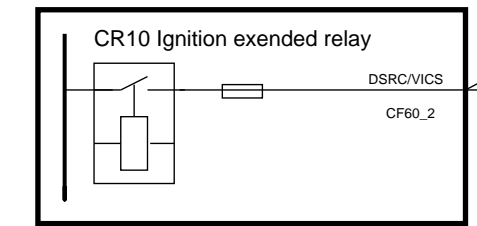

15/50 CENTRAL JUNCTION BOX

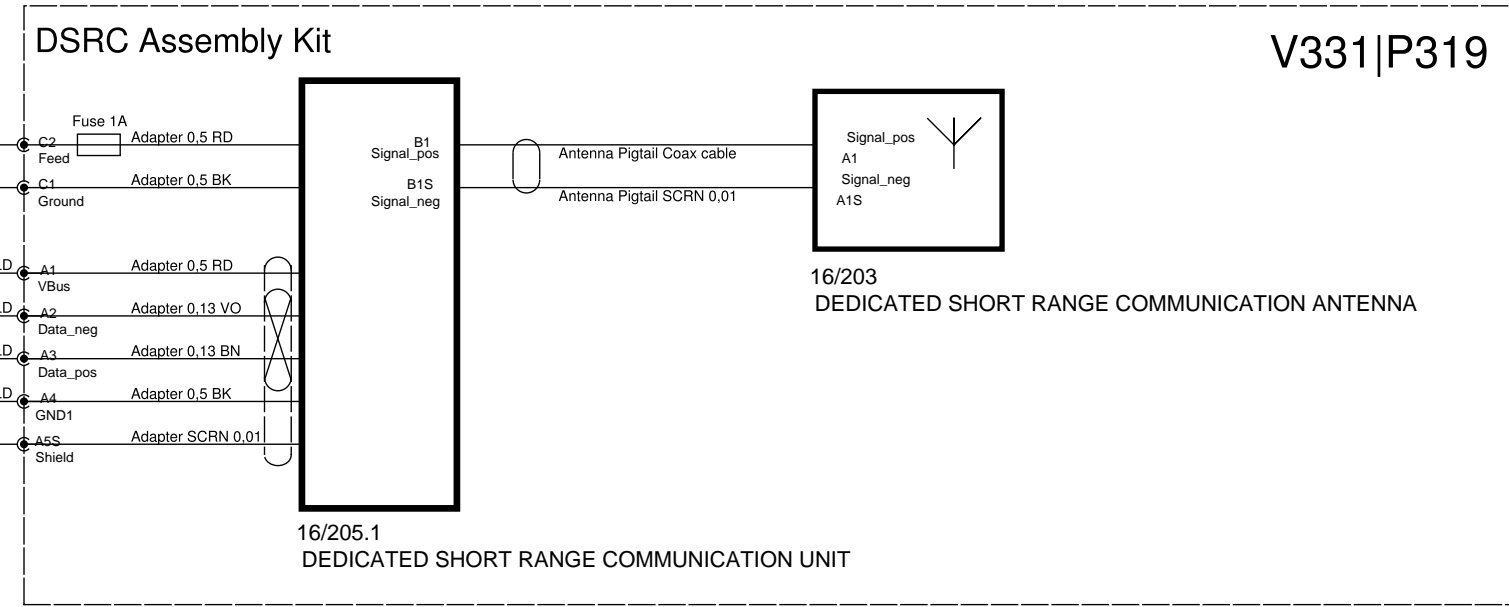
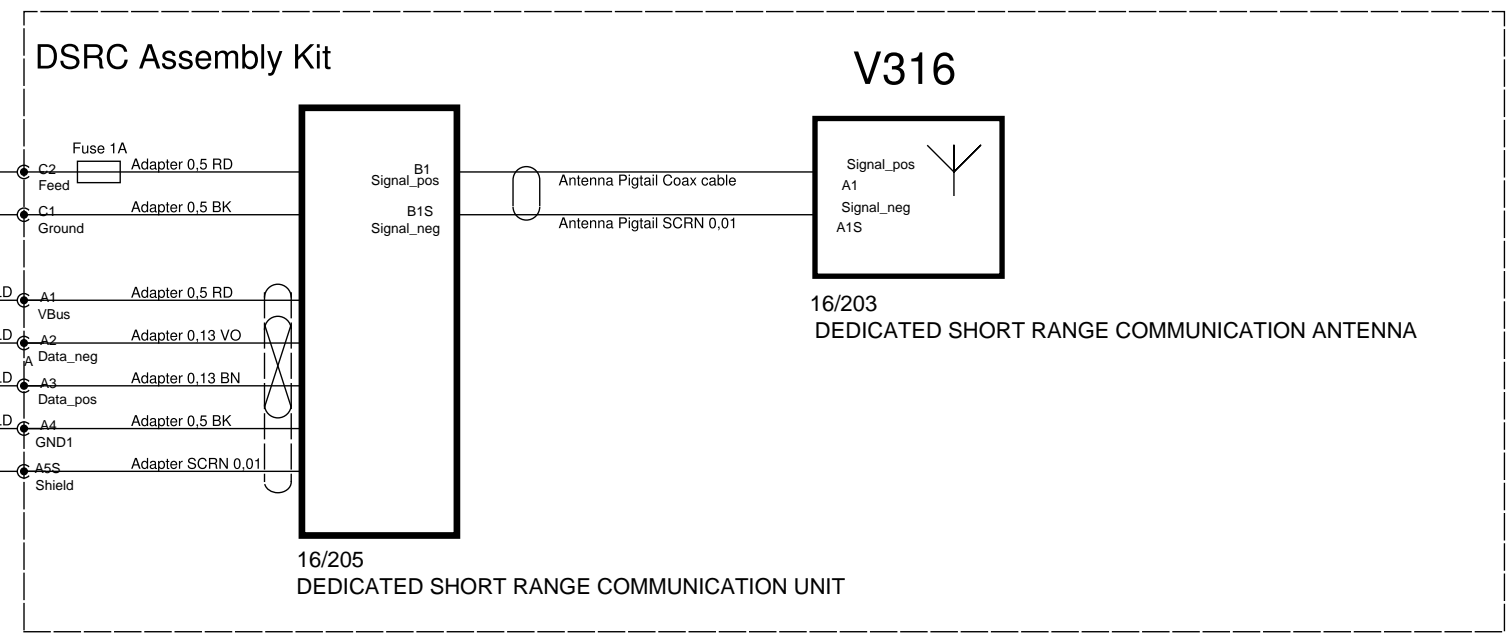
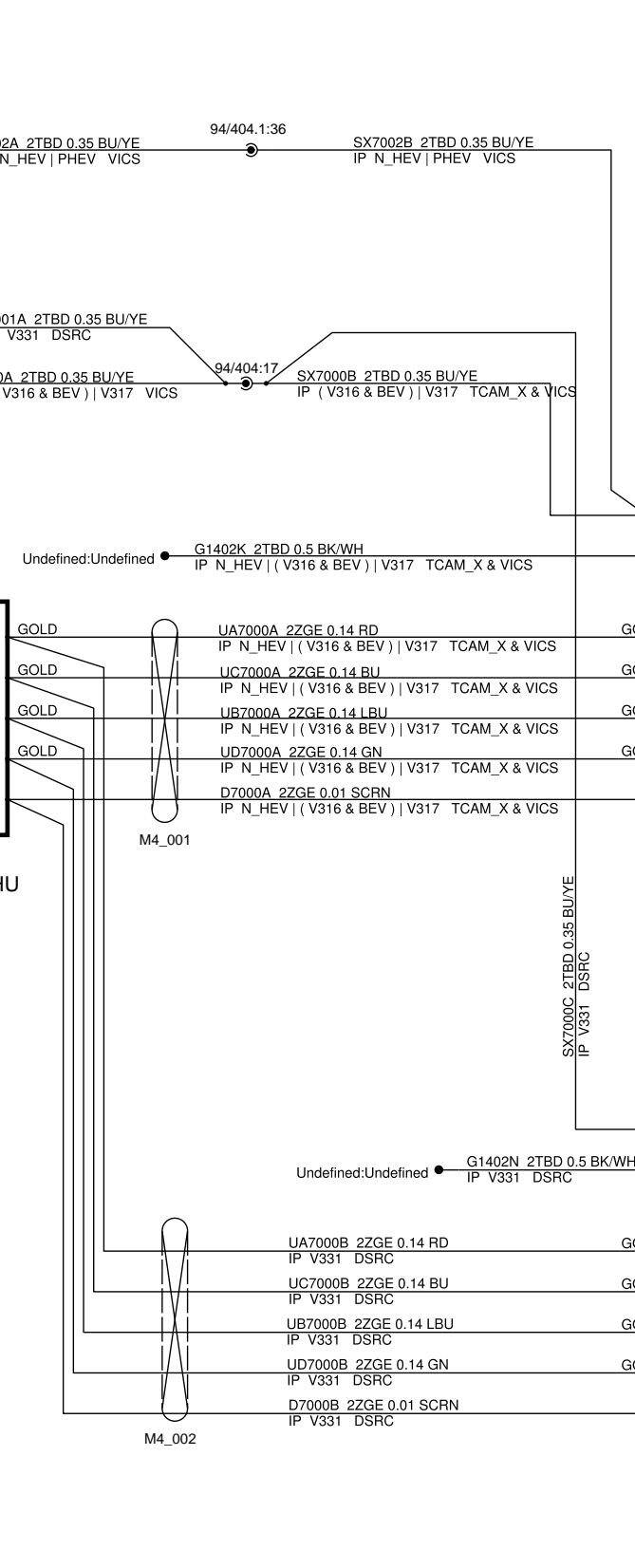
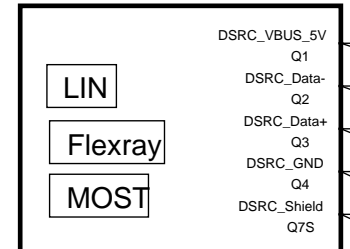

<p>The copying, distribution and utilization of this document as well as the communication of its contents to others without expressed authorization is prohibited. Offenders will be held liable for payment of damages. All rights reserved in the event of the grant of a patent, utility model or ornamental design registration.</p> <p><b>VOLVO</b> VOLVO CAR CORPORATION</p>	<p><b>Document title</b> CMA_622A_CC_All_5_30</p> <p>7C_DSRC</p>	
	<p><b>Document Type</b></p> <p>DRAW/ELSY</p>	<p><b>Release Status</b></p> <p>RELEASED</p>
	<p>CEVT Document No</p> <p>8888522365</p>	<p><b>Edited</b></p> <p>June/16/2021</p>
	<p><b>Issue</b></p> <p>030</p>	<p><b>Page No</b></p> <p>125/149</p>

# 7F Electronic Toll Collection

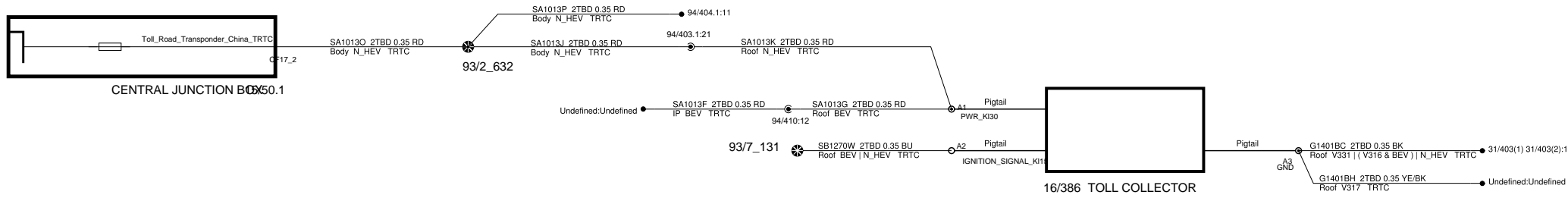

<p>The copying, distribution and utilization of this document as well as the communication of its contents to others without expressed authorization is prohibited. Offenders will be held liable for payment of damages. All rights reserved in the event of the grant of a patent, utility model or ornamental design registration.</p> <p><b>VOLVO</b> VOLVO CAR CORPORATION</p>	<b>Document title</b> CMA_622A_CC_All_5_30 7F_Electronic_Toll_Collection	
	<b>Document Type</b> DRAW/ELSY	<b>Release Status</b> RELEASED
	CEVT Document No 8888522365	<b>Edited</b> February/18/2022
	<b>Issue</b> 030	<b>Page No</b> 127/149



# 8A Exterior Light Front

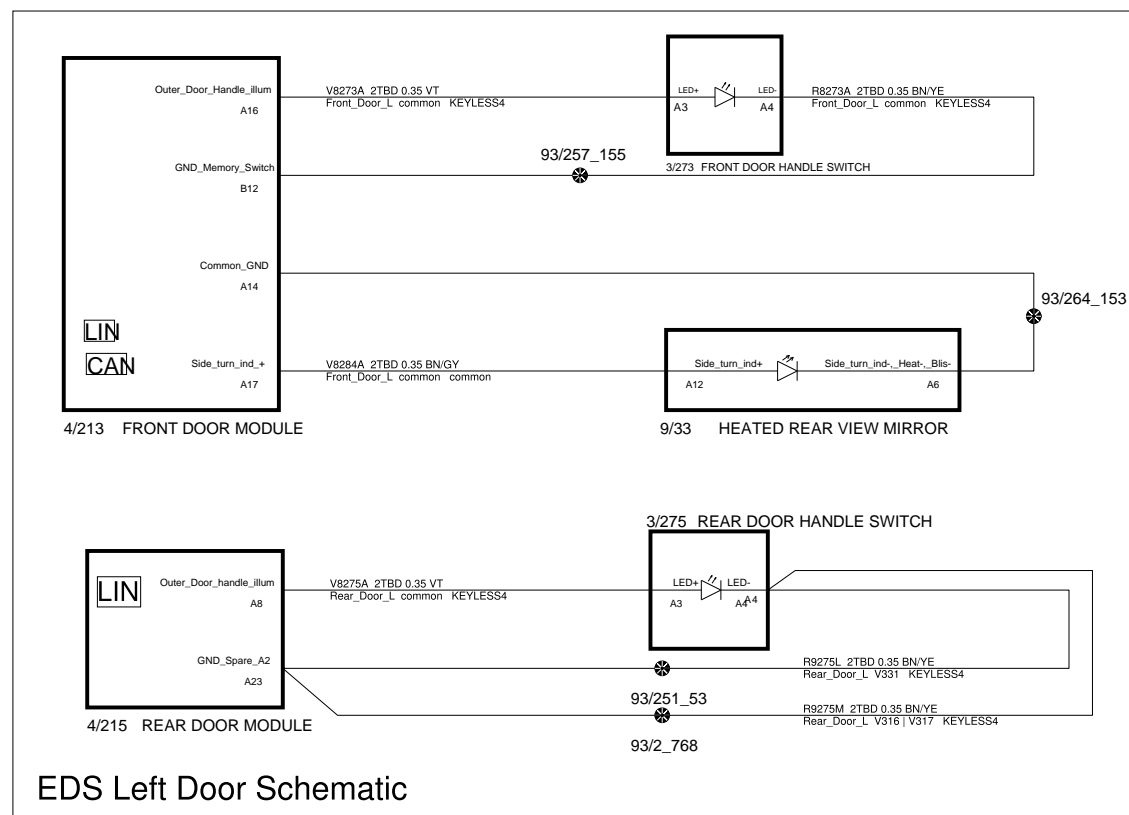
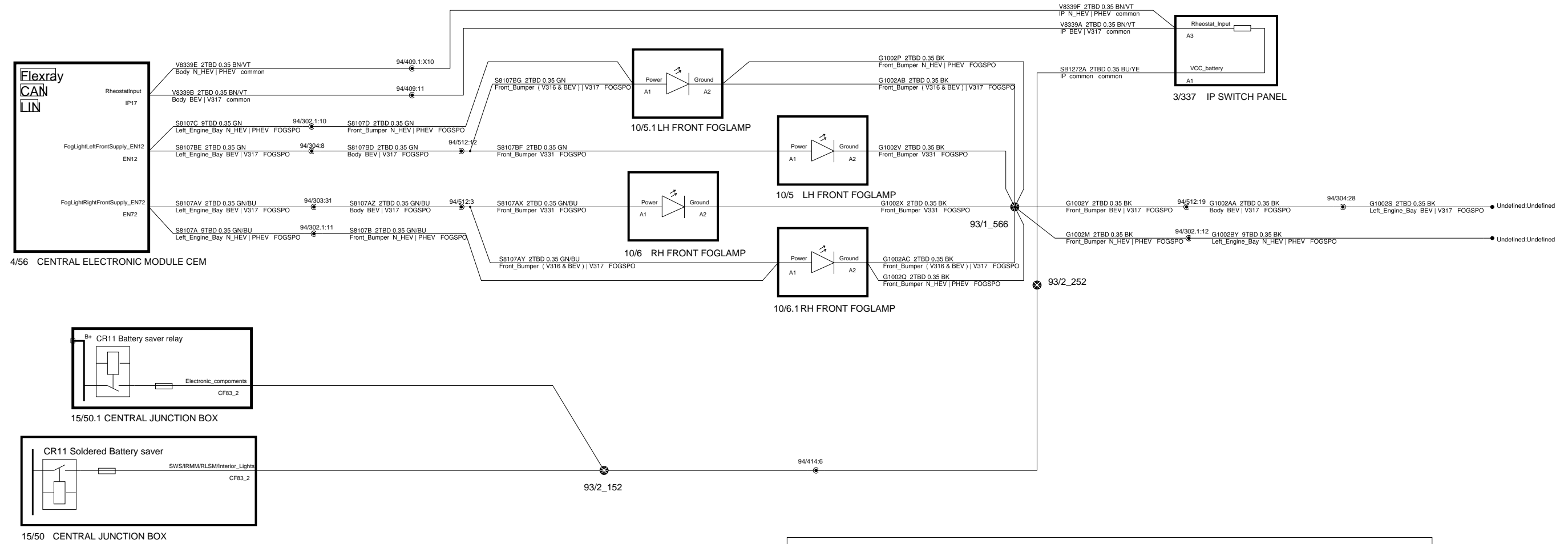

EDS Left Door Schematic

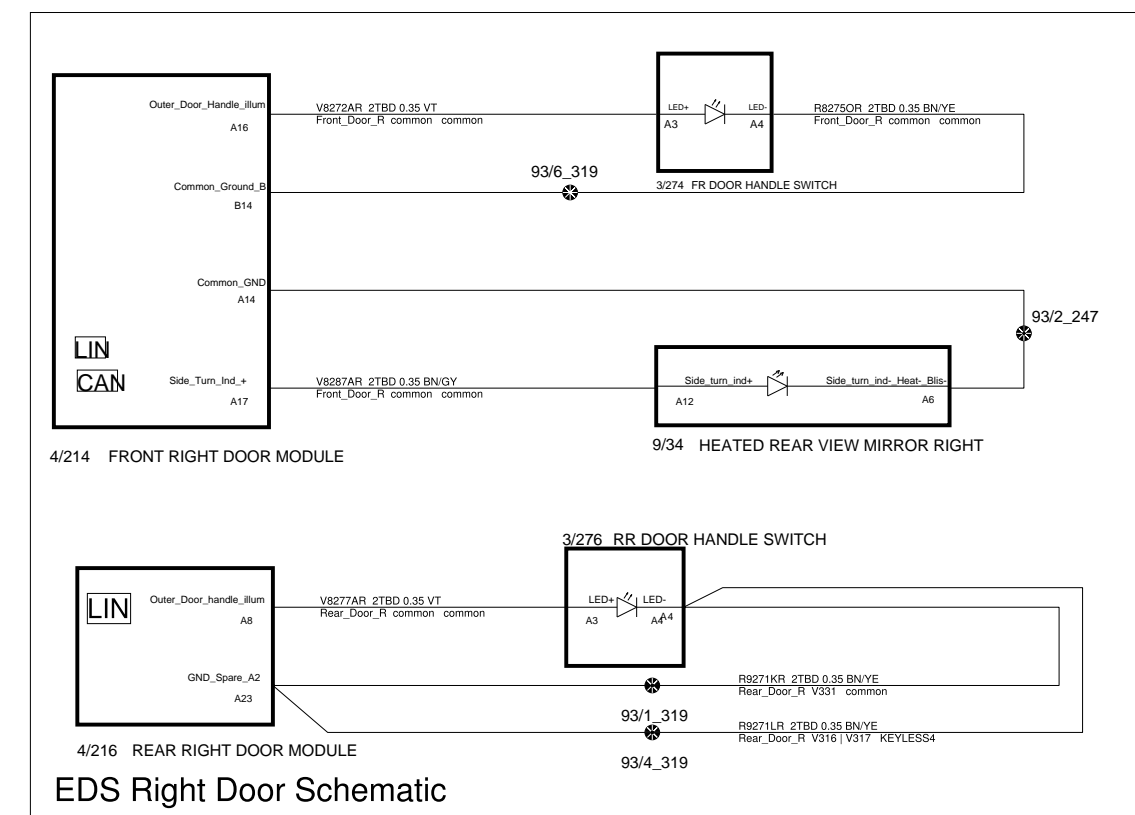

EDS Right Door Schematic

The copying, distribution and utilization of this document as well as the communication of its contents to others without expressed authorization is prohibited. Offenders will be held liable for payment of damages. All rights reserved in the event of the grant of a patent, utility model or ornamental design registration.

**VOLVO**  
VOLVO CAR CORPORATION

<b>Document title</b> 8A_Exterior_Light_Front		CMA_622A_CC_A11_5_30	
<b>Document Type</b> DRAW/ELSY	<b>Release Status</b> RELEASED		
Volvo Document No 33445458		<b>Edited</b> February/28/2022	
<b>Issue</b> 030	<b>Page No</b> 128/149		

# 8A Exterior Light LED Front

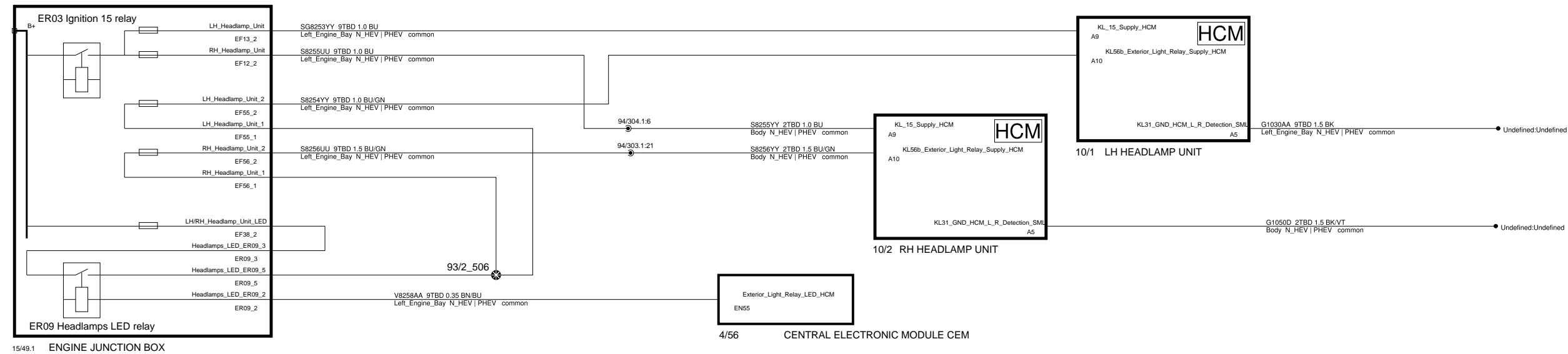
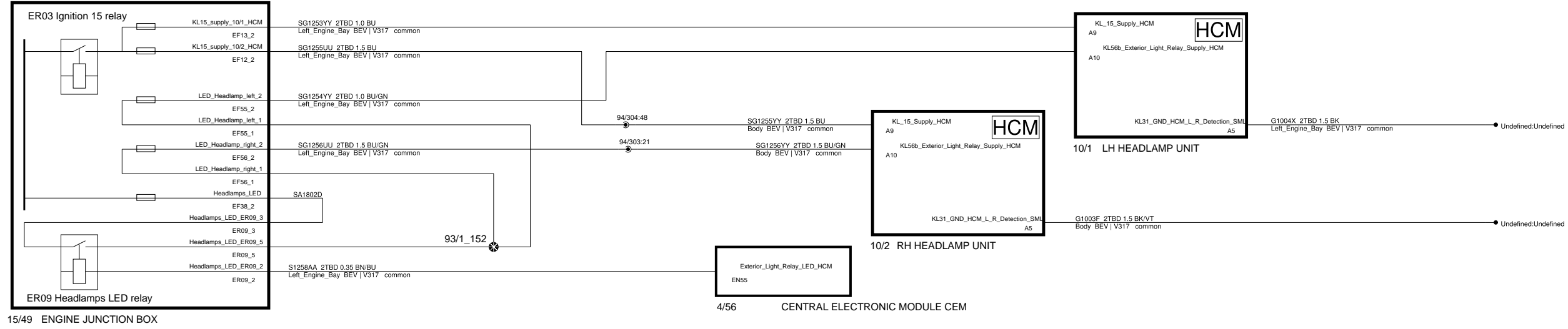

<p>The copying, distribution and utilization of this document as well as the communication of its contents to others without expressed authorization is prohibited. Offenders will be held liable for payment of damages. All rights reserved in the event of the grant of a patent, utility model or ornamental design registration.</p> <p><b>VOLVO</b> VOLVO CAR CORPORATION</p>	<b>Document title</b> CMA_622A_CC_All_5_30 8A_Exterior_Light_LED_Front	
	<b>Document Type</b> DRAW/ELSY	<b>Release Status</b> RELEASED
	Volvo Document No 33445458	<b>Edited</b> May/26/2022
	<b>Issue</b> 030	<b>Page No</b> 129/149

# 8A Exterior Light Rear V316

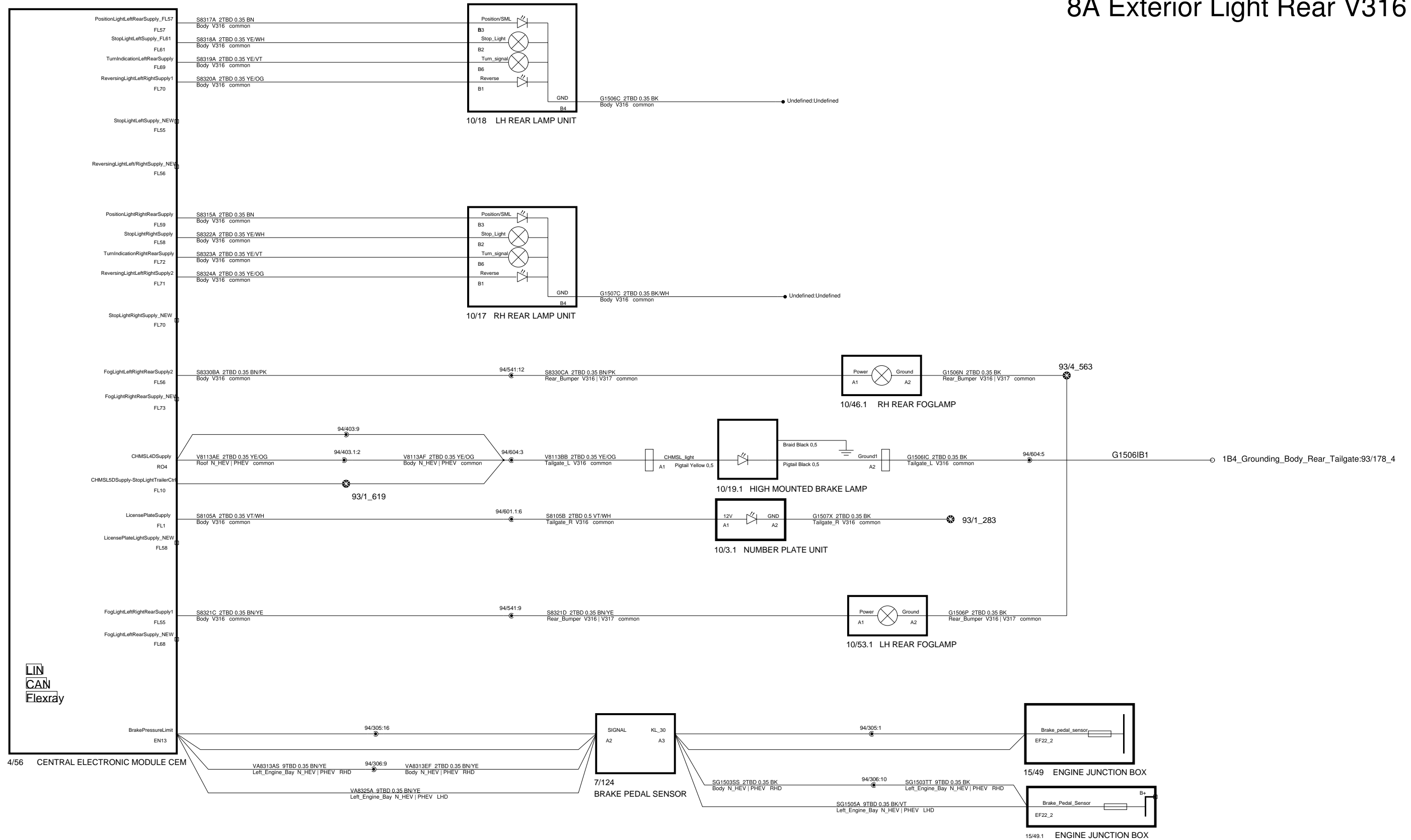

<p>The copying, distribution and utilization of this document as well as the communication of its contents to others without expressed authorization is prohibited. Offenders will be held liable for payment of damages. All rights reserved in the event of the grant of a patent, utility model or ornamental design registration.</p> <p><b>VOLVO</b> VOLVO CAR CORPORATION</p>		<b>Document title</b> CMA_622A_CC_All_5_30 8A_Exterior_Light_Rear_V316	
		<b>Document Type</b> DRAW/ELSY	<b>Release Status</b> RELEASED
		CEVT Document No 8888522365	<b>Edited</b> March/17/2022
		<b>Issue</b> 030	<b>Page No</b> 130/149

# 8A Exterior Light Rear V331

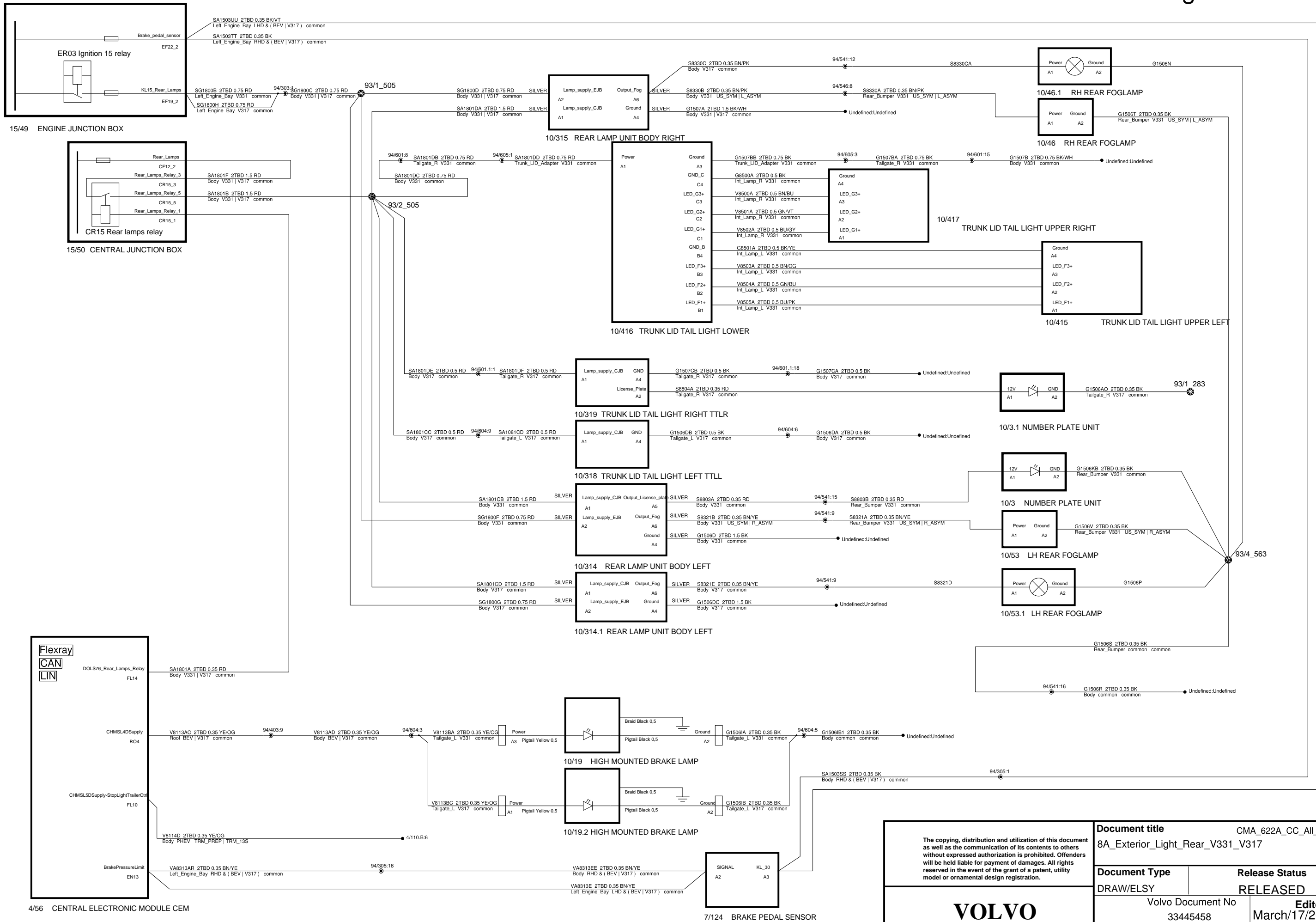

<p>The copying, distribution and utilization of this document as well as the communication of its contents to others without expressed authorization is prohibited. Offenders will be held liable for payment of damages. All rights reserved in the event of the grant of a patent, utility model or ornamental design registration.</p> <p><b>VOLVO</b> VOLVO CAR CORPORATION</p>		<p><b>Document title</b> CMA_622A_CC_All_5_30 8A_Exterior_Light_Rear_V331_V317</p>	
		<p><b>Document Type</b> DRAW/ELSY</p>	<p><b>Release Status</b> RELEASED</p>
<p>Volvo Document No 33445458</p>		<p><b>Edited</b> March/17/2022</p>	
<p><b>Issue</b> 030</p>		<p><b>Page No</b> 131/149</p>	

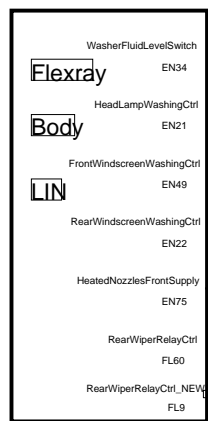

4/56 CENTRAL ELECTRONIC MODULE CEM

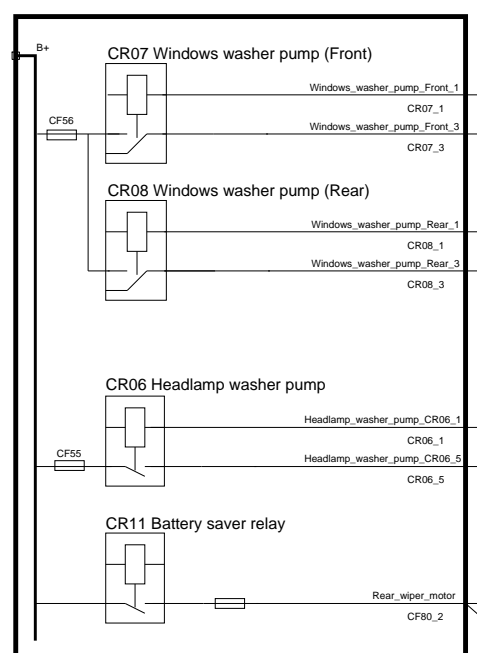

15/50.1 CENTRAL JUNCTION BOX

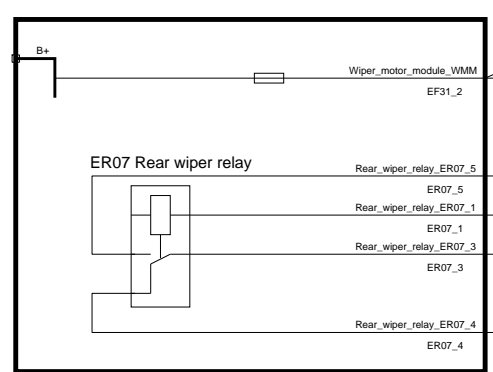

15/49.1 ENGINE JUNCTION BOX

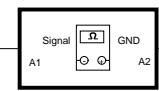

7/5 WASHER FLUID LEVEL SENSOR

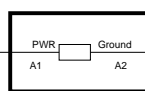

9/43 ELECTRIC HEATED WASHER NOZZLE WINDSCREEN LH SIDE

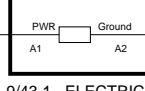

9/43.1 ELECTRIC HEATED WASHER NOZZLE WINDSCREEN LH SIDE

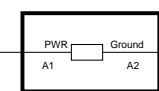

9/44 ELECTRIC HEATED WASHER NOZZLE WINDSCREEN RH SIDE

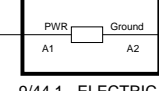

9/44.1 ELECTRIC HEATED WASHER NOZZLE WINDSCREEN RH SIDE

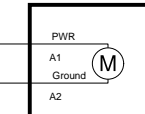

6/127 FRONT/REAR WINDOW WASHER PUMP

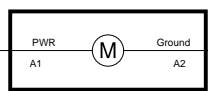

6/104 HIGH PRESSURE WASHER PUMP HEAD LAMPS



4/250.1 WIPER MOTOR MODULE WMM

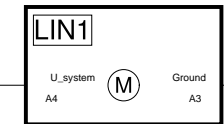

4/250 WIPER MOTOR MODULE WMM

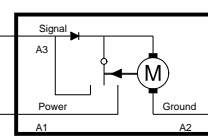

6/32 REAR WIPER MOTOR

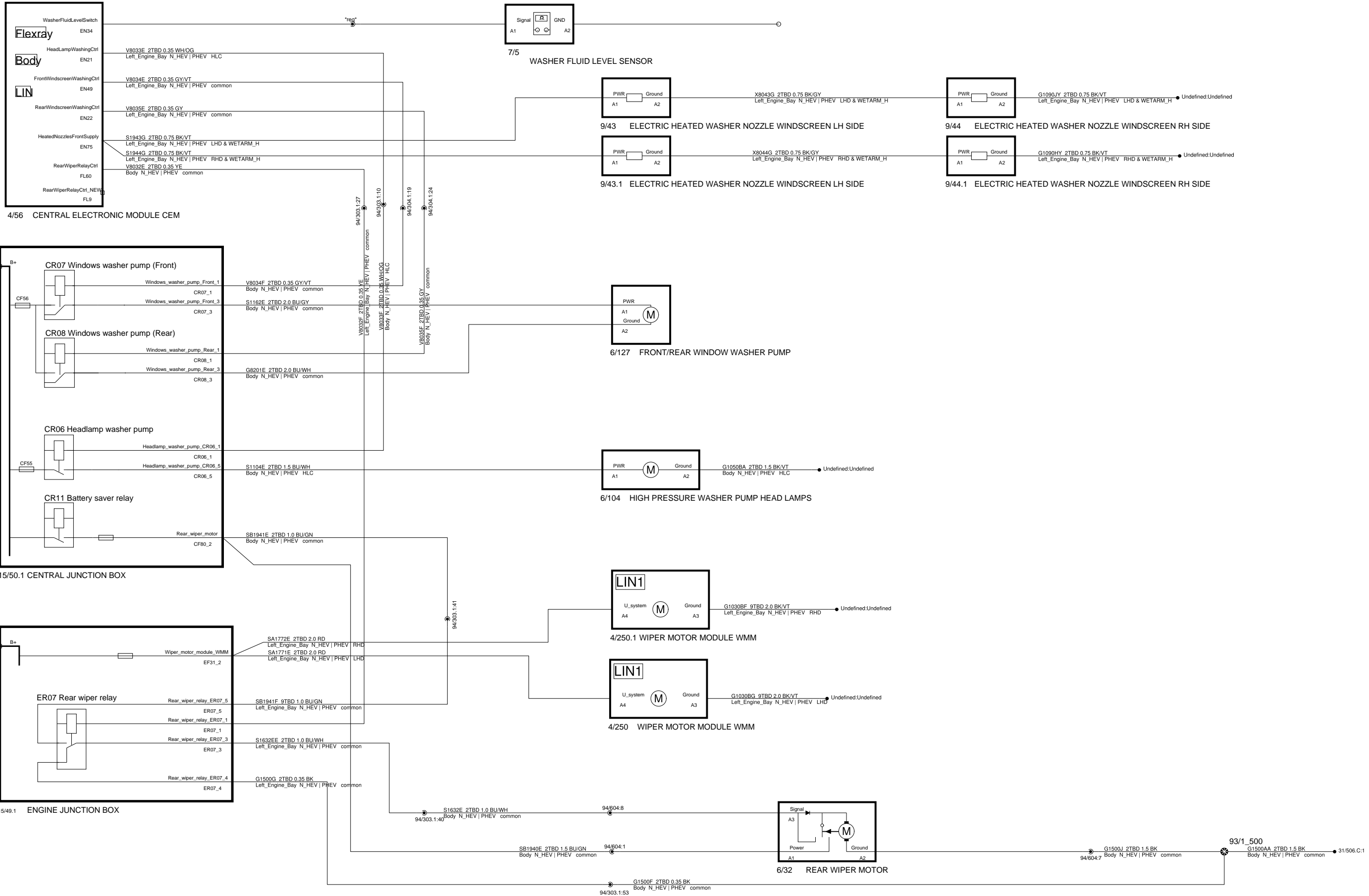

# 8K Lamp cleaning control 8H Windscreen cleaning control 8J Rear window cleaning

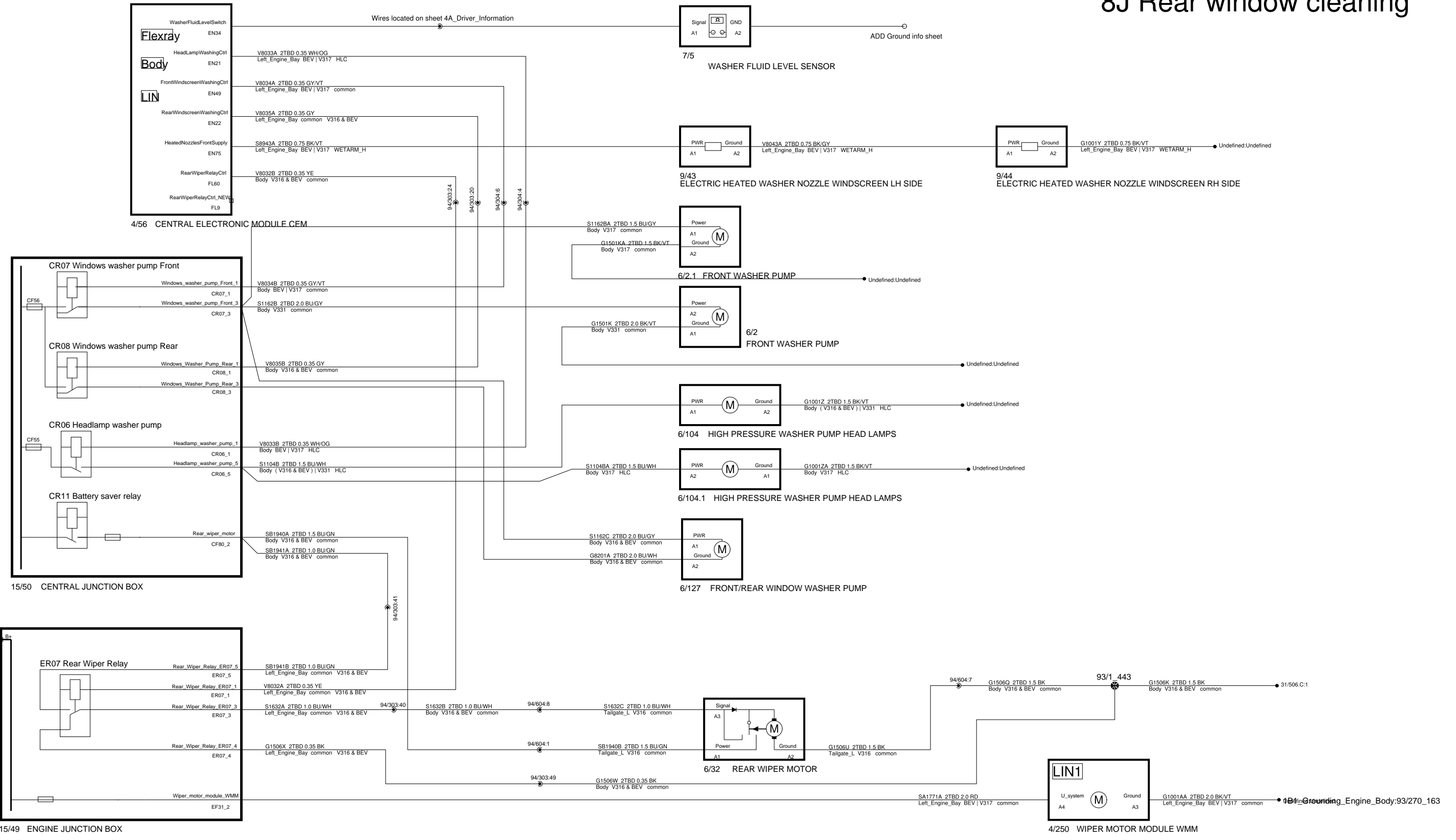

<p>The copying, distribution and utilization of this document as well as the communication of its contents to others without expressed authorization is prohibited. Offenders will be held liable for payment of damages. All rights reserved in the event of the grant of a patent, utility model or ornamental design registration.</p>		<p><b>Document title</b> CMA_622A_CC_All_5_30 8K_8H_8J_Lamp_windscreen_rear_window_cleaning</p>	
		<p><b>Document Type</b> DRAW/ELSY</p>	<p><b>Release Status</b> RELEASED</p>
<p><b>VOLVO</b> VOLVO CAR CORPORATION</p>		<p>Volvo Document No 33445458</p>	<p><b>Edited</b> May/26/2022</p>
		<p><b>Issue</b> 030</p>	<p><b>Page No</b> 132/149</p>

# 8N Windscreen defroster control 8L Rear window defroster control

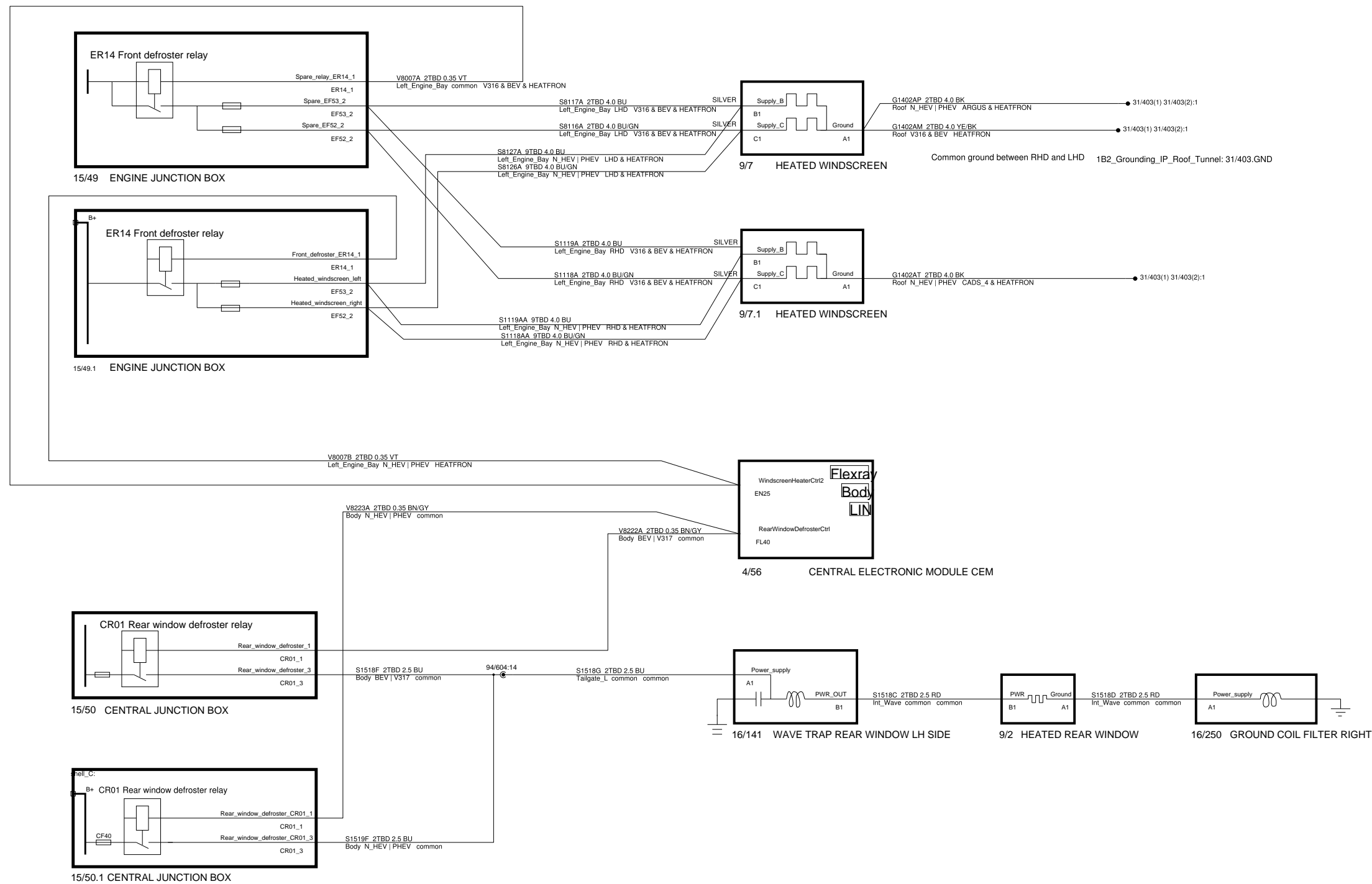

<p>The copying, distribution and utilization of this document as well as the communication of its contents to others without expressed authorization is prohibited. Offenders will be held liable for payment of damages. All rights reserved in the event of the grant of a patent, utility model or ornamental design registration.</p> <p><b>VOLVO</b> VOLVO CAR CORPORATION</p>	<b>Document title</b> CMA_622A_CC_All_5_30 8N_8L_Windscreen_rear_window_defroster	
	<b>Document Type</b> DRAW/ELSY	<b>Release Status</b> RELEASED
	Volvo Document No 33445458	<b>Edited</b> May/29/2022
	<b>Issue</b> 030	<b>Page No</b> 134/149

# 8P Sound Signaling

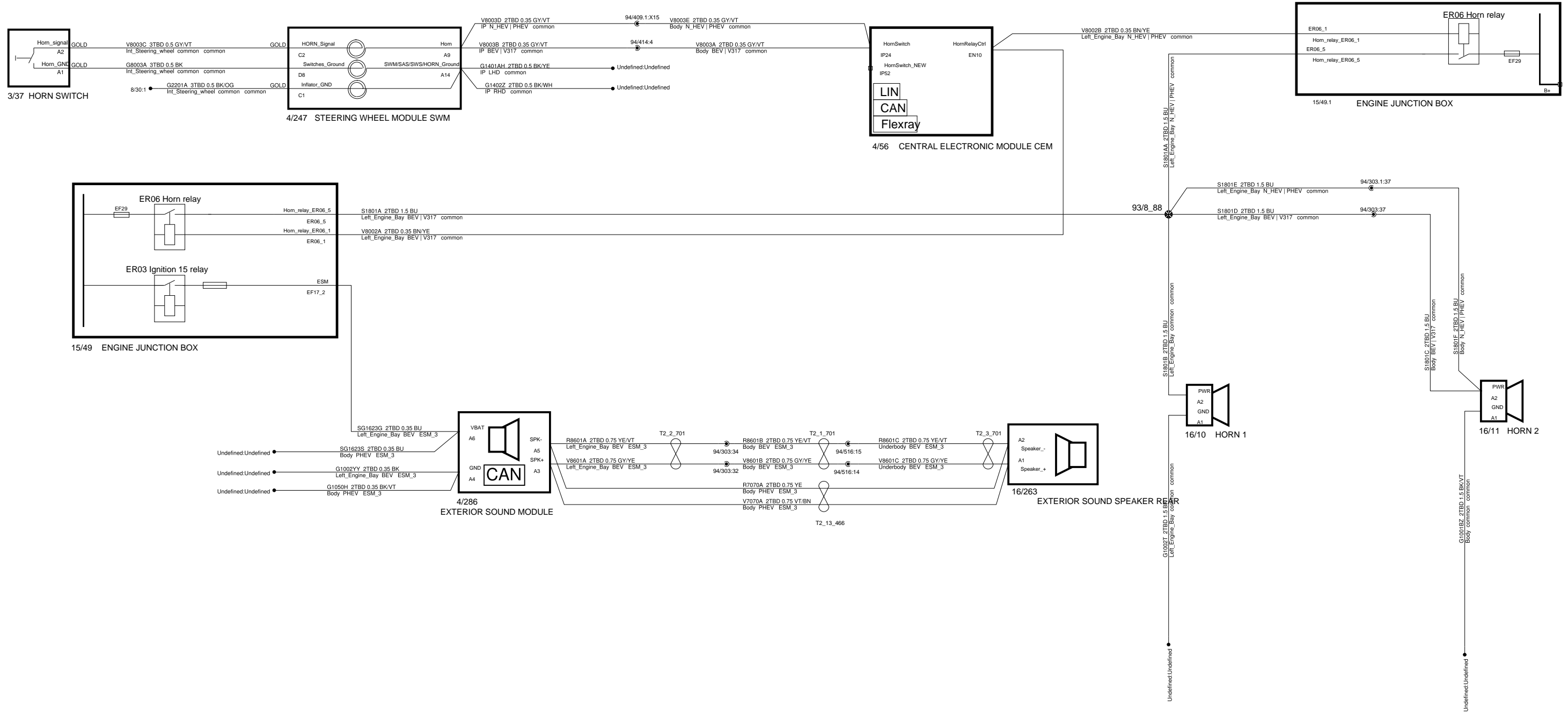

<p>The copying, distribution and utilization of this document as well as the communication of its contents to others without expressed authorization is prohibited. Offenders will be held liable for payment of damages. All rights reserved in the event of the grant of a patent, utility model or ornamental design registration.</p> <p><b>VOLVO</b> VOLVO CAR CORPORATION</p>	<b>Document title</b> CMA_622A_CC_All_5_30 8P_Sound_signaling	
	<b>Document Type</b> DRAW/ELSY	<b>Release Status</b> RELEASED
	Volvo Document No 33445458	Edited May/29/2022
	<b>Issue</b> 030	Page No 135/149



# 9A Interior Lights Doors Right

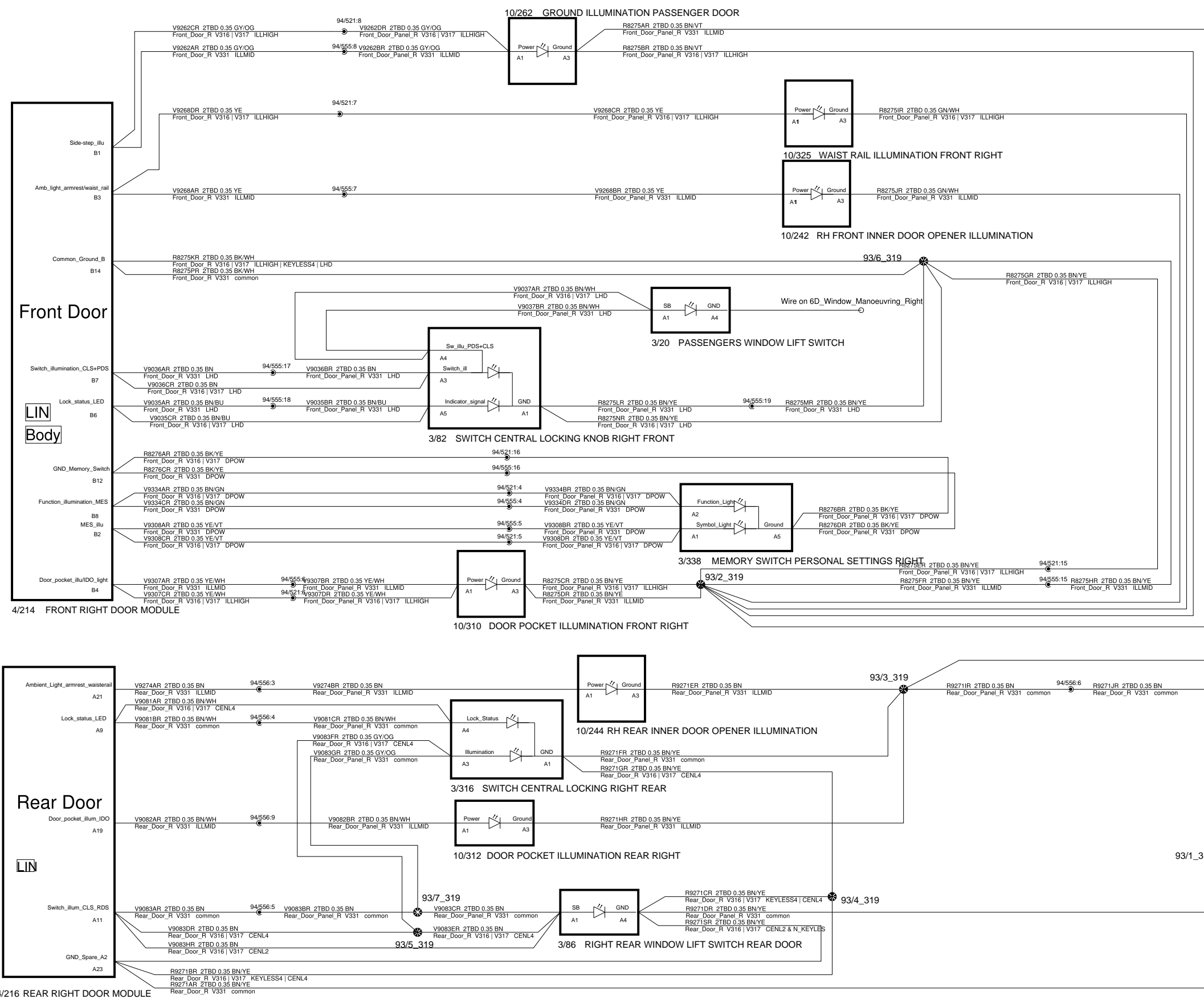

<p>The copying, distribution and utilization of this document as well as the communication of its contents to others without expressed authorization is prohibited. Offenders will be held liable for payment of damages. All rights reserved in the event of the grant of a patent, utility model or ornamental design registration.</p> <p><b>VOLVO</b> VOLVO CAR CORPORATION</p>		<p><b>Document title</b> CMA_622A_CC_A11_5_30 9A_Interior_Lights_Doors_Right</p>	
		<p><b>Document Type</b> DRAW/ELSY</p>	<p><b>Release Status</b> RELEASED</p>
<p>CEVT Document No 8888522365</p>		<p><b>Edited</b> February/28/2022</p>	
<p><b>Issue</b> 030</p>		<p><b>Page No</b> 138/149</p>	

# 9A Interior Lights Doors

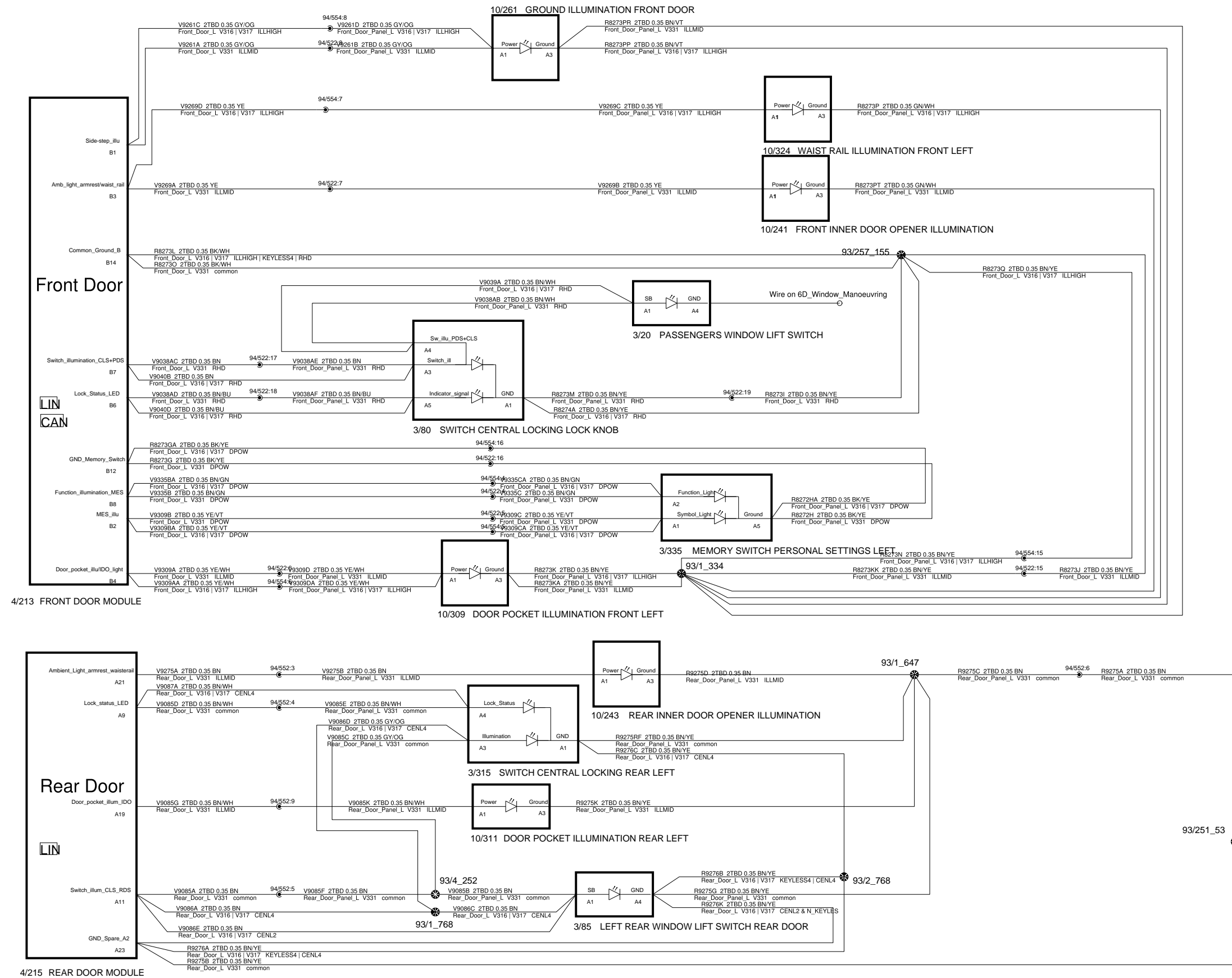

<p>The copying, distribution and utilization of this document as well as the communication of its contents to others without expressed authorization is prohibited. Offenders will be held liable for payment of damages. All rights reserved in the event of the grant of a patent, utility model or ornamental design registration.</p> <p><b>VOLVO</b> VOLVO CAR CORPORATION</p>	<b>Document title</b> CMA_622A_CC_All_5_30	
	9A_Interior_Lights_Doors	
	<b>Document Type</b> DRAW/ELSY	<b>Release Status</b> RELEASED
	Volvo Document No 33445458	<b>Edited</b> February/28/2022
<b>Issue</b> 030	<b>Page No</b> 137/149	

# 9A Interior Lights

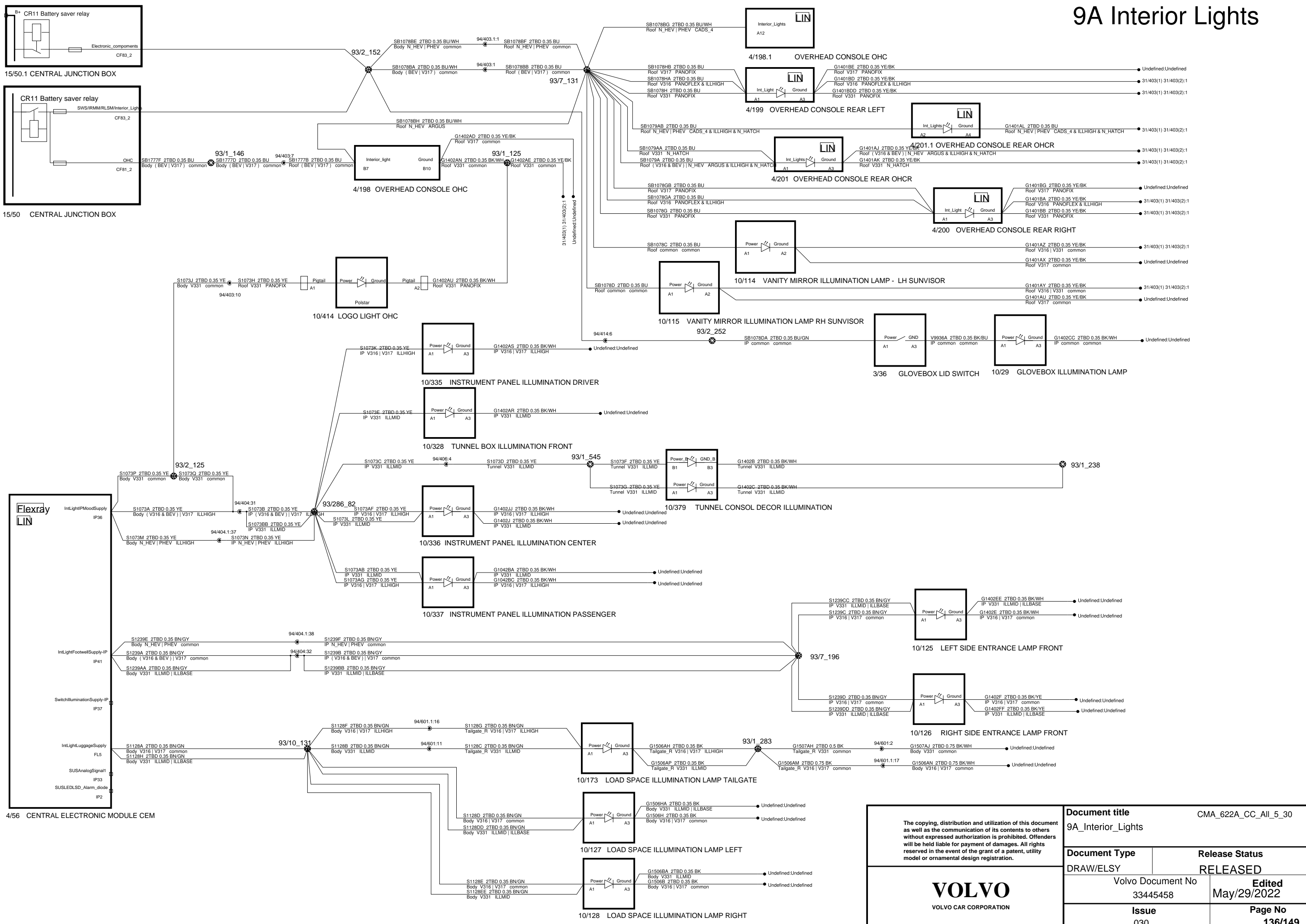

<p>The copying, distribution and utilization of this document as well as the communication of its contents to others without expressed authorization is prohibited. Offenders will be held liable for payment of damages. All rights reserved in the event of the grant of a patent, utility model or ornamental design registration.</p> <p><b>VOLVO</b> VOLVO CAR CORPORATION</p>		<b>Document title</b> 9A_Interior_Lights CMA_622A_CC_All_5_30	
		<b>Document Type</b> DRAW/ELSY	<b>Release Status</b> RELEASED
		<b>Volvo Document No</b> 33445458	<b>Edited</b> May/29/2022
		<b>Issue</b> 030	<b>Page No</b> 136/149

# 9H Instr/Control Switch Lighting

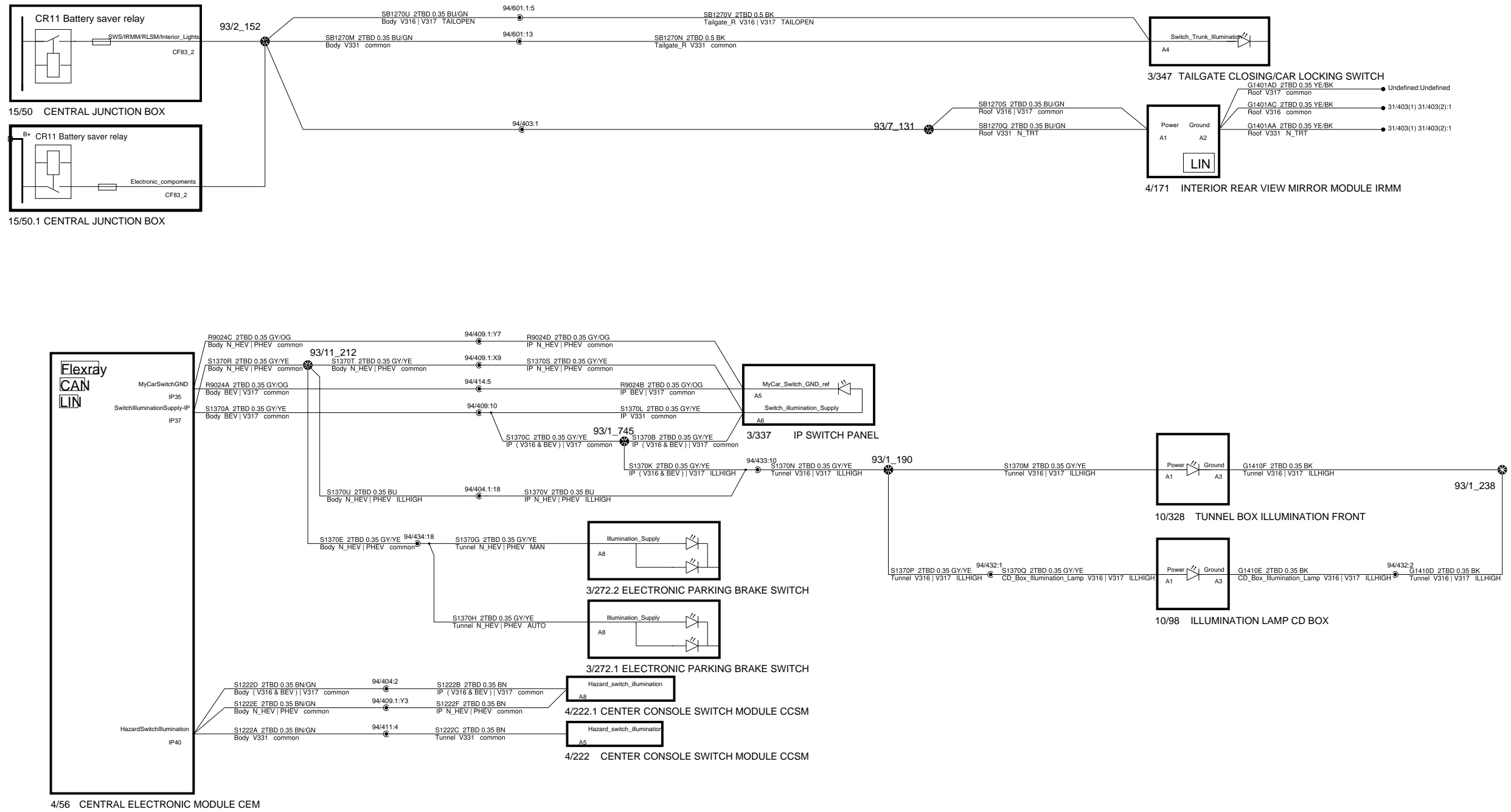

<p>The copying, distribution and utilization of this document as well as the communication of its contents to others without expressed authorization is prohibited. Offenders will be held liable for payment of damages. All rights reserved in the event of the grant of a patent, utility model or ornamental design registration.</p> <p><b>VOLVO</b> VOLVO CAR CORPORATION</p>	<b>Document title</b> CMA_622A_CC_All_5_30 9H_Instr_Control_Switch_Lighting	
	<b>Document Type</b> DRAW/ELSY	<b>Release Status</b> RELEASED
	Volvo Document No 33445458	<b>Edited</b> February/18/2022
	<b>Issue</b> 030	<b>Page No</b> 139/149

# 10A Driver Seat Internal Harness High LHD

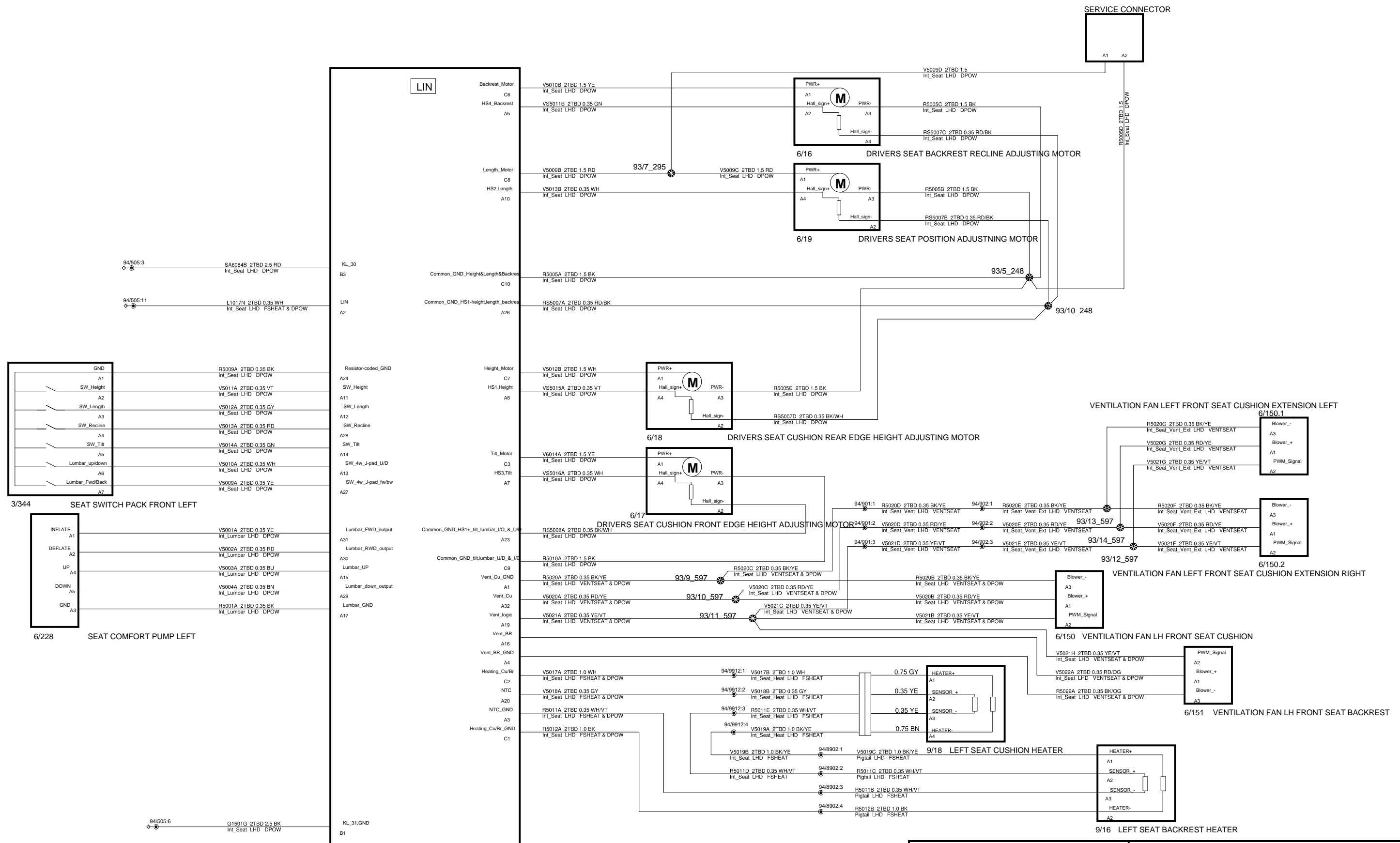

<p>The copying, distribution and utilization of this document as well as the communication of its contents to others without expressed authorization is prohibited. Offenders will be held liable for payment of damages. All rights reserved in the event of the grant of a patent, utility model or ornamental design registration.</p> <p><b>VOLVO</b> VOLVO CAR CORPORATION</p>		<p><b>Document title</b> CMA_622A_CC_All_5_30 10A_Driver_Seat_Internal_Harness_High_LHD</p>	
		<p><b>Document Type</b> DRAW/ELSY</p>	<p><b>Release Status</b> RELEASED</p>
		<p>Volvo Document No 33445458</p>	<p><b>Edited</b> March/04/2022</p>
		<p><b>Issue</b> 030</p>	<p><b>Page No</b> 140/149</p>

# 10A Driver Seat Internal Harness High RHD

SERVICE CONNECTOR

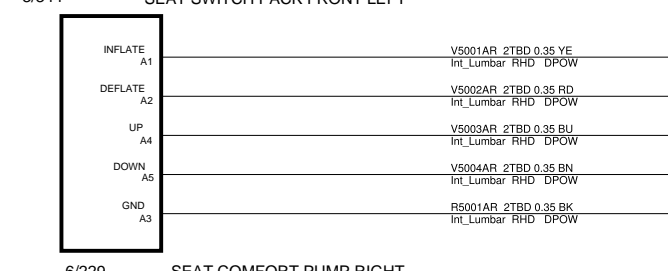
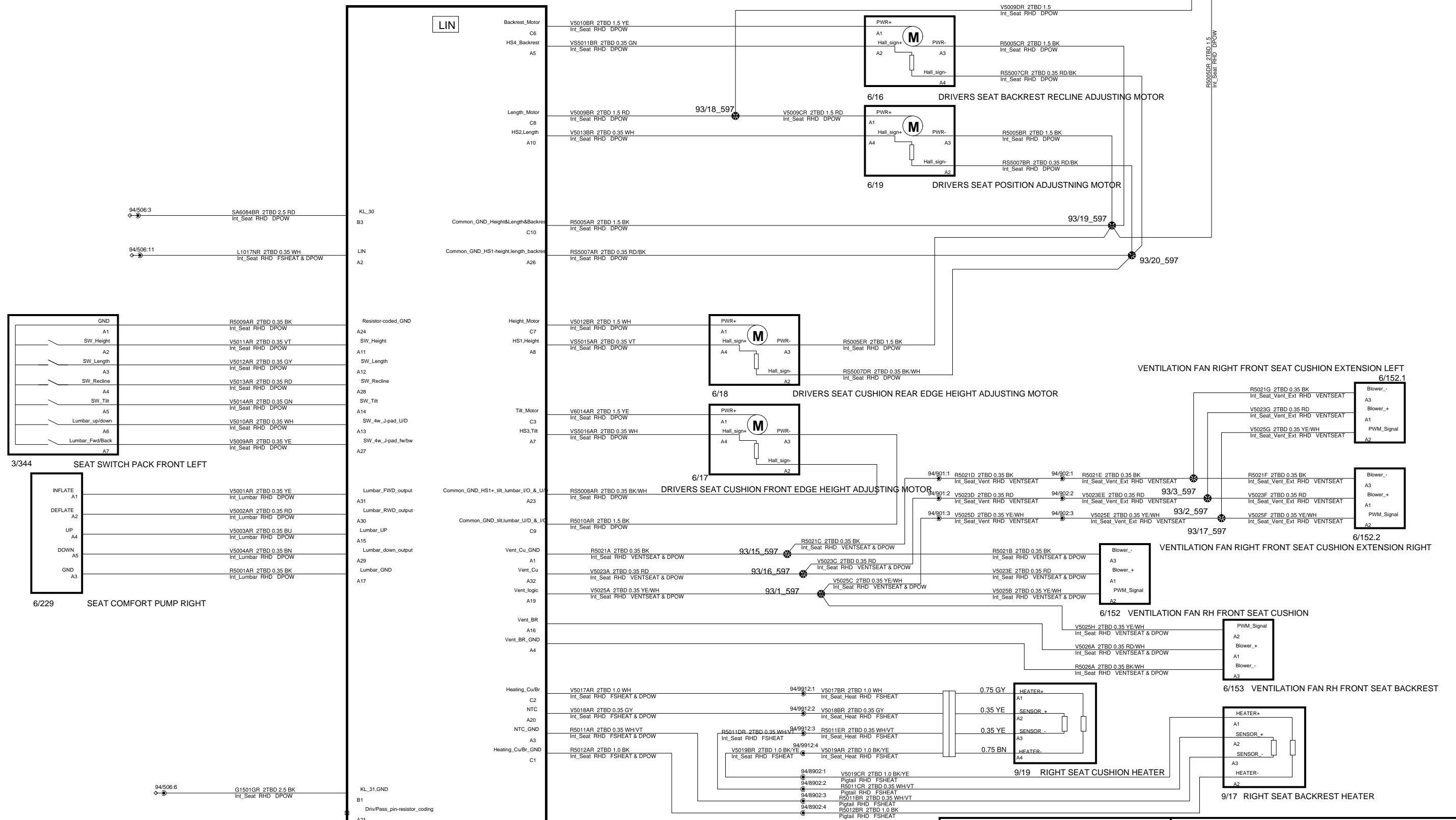

The copying, distribution and utilization of this document as well as the communication of its contents to others without expressed authorization is prohibited. Offenders will be held liable for payment of damages. All rights reserved in the event of the grant of a patent, utility model or ornamental design registration.

**VOLVO**  
VOLVO CAR CORPORATION

<b>Document title</b>		CMA_622A_CC_All_5_30	
10A_Driver_Seat_Internal_Harness_High_RHD			
<b>Document Type</b>	<b>Release Status</b>		
DRAW/ELSY	RELEASED		
Volvo Document No		<b>Edited</b>	
33445458		March/10/2022	
<b>Issue</b>		<b>Page No</b>	
030		141/149	

# 10A Driver Seat Internal Harness Mech LHD

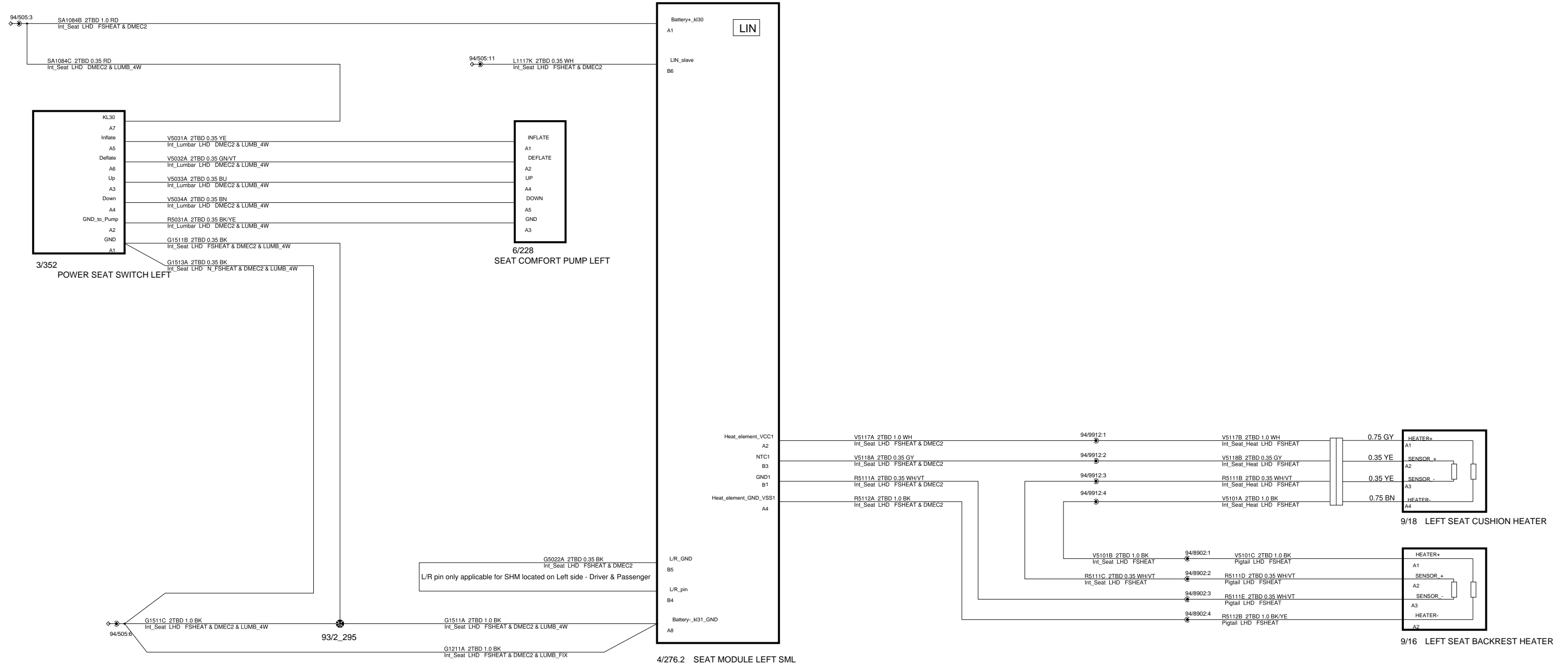

<p>The copying, distribution and utilization of this document as well as the communication of its contents to others without expressed authorization is prohibited. Offenders will be held liable for payment of damages. All rights reserved in the event of the grant of a patent, utility model or ornamental design registration.</p> <p><b>VOLVO</b> VOLVO CAR CORPORATION</p>	<b>Document title</b> CMA_622A_CC_All_5_30 10A_Driver_Seat_Internal_Harness_Mech_LHD	
	<b>Document Type</b> DRAW/ELSY	<b>Release Status</b> RELEASED
	Volvo Document No 33445458	<b>Edited</b> March/04/2022
	<b>Issue</b> 030	<b>Page No</b> 142/149

# 10A Driver Seat Internal Harness Mech RHD

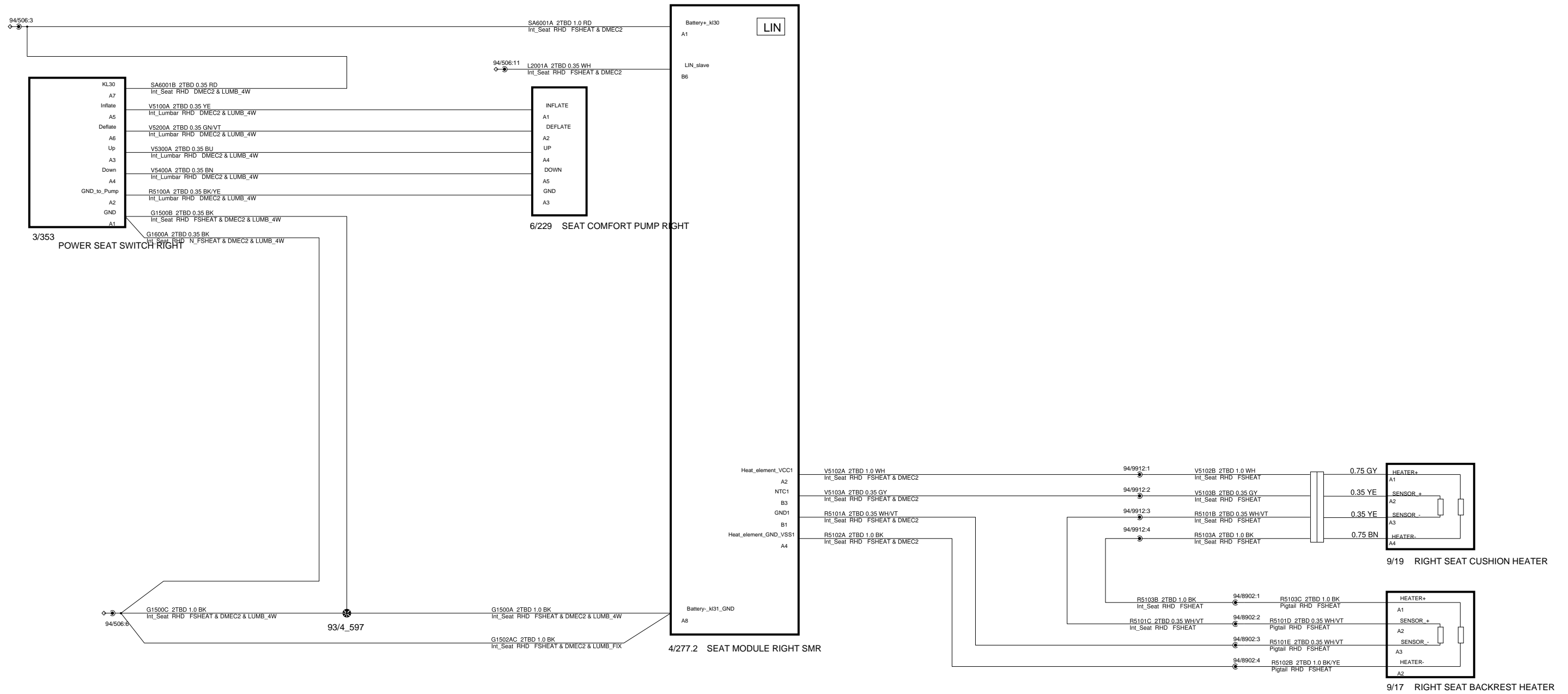

<p>The copying, distribution and utilization of this document as well as the communication of its contents to others without expressed authorization is prohibited. Offenders will be held liable for payment of damages. All rights reserved in the event of the grant of a patent, utility model or ornamental design registration.</p> <p><b>VOLVO</b> VOLVO CAR CORPORATION</p>	<b>Document title</b> CMA_622A_CC_All_5_30 10A_Driver_Seat_Internal_Harness_Mech_RHD	
	<b>Document Type</b> DRAW/ELSY	<b>Release Status</b> RELEASED
	Volvo Document No 33445458	<b>Edited</b> March/18/2022
	<b>Issue</b> 030	<b>Page No</b> 143/149



# 10A Interior HVAC harness 2 ZONES ECC

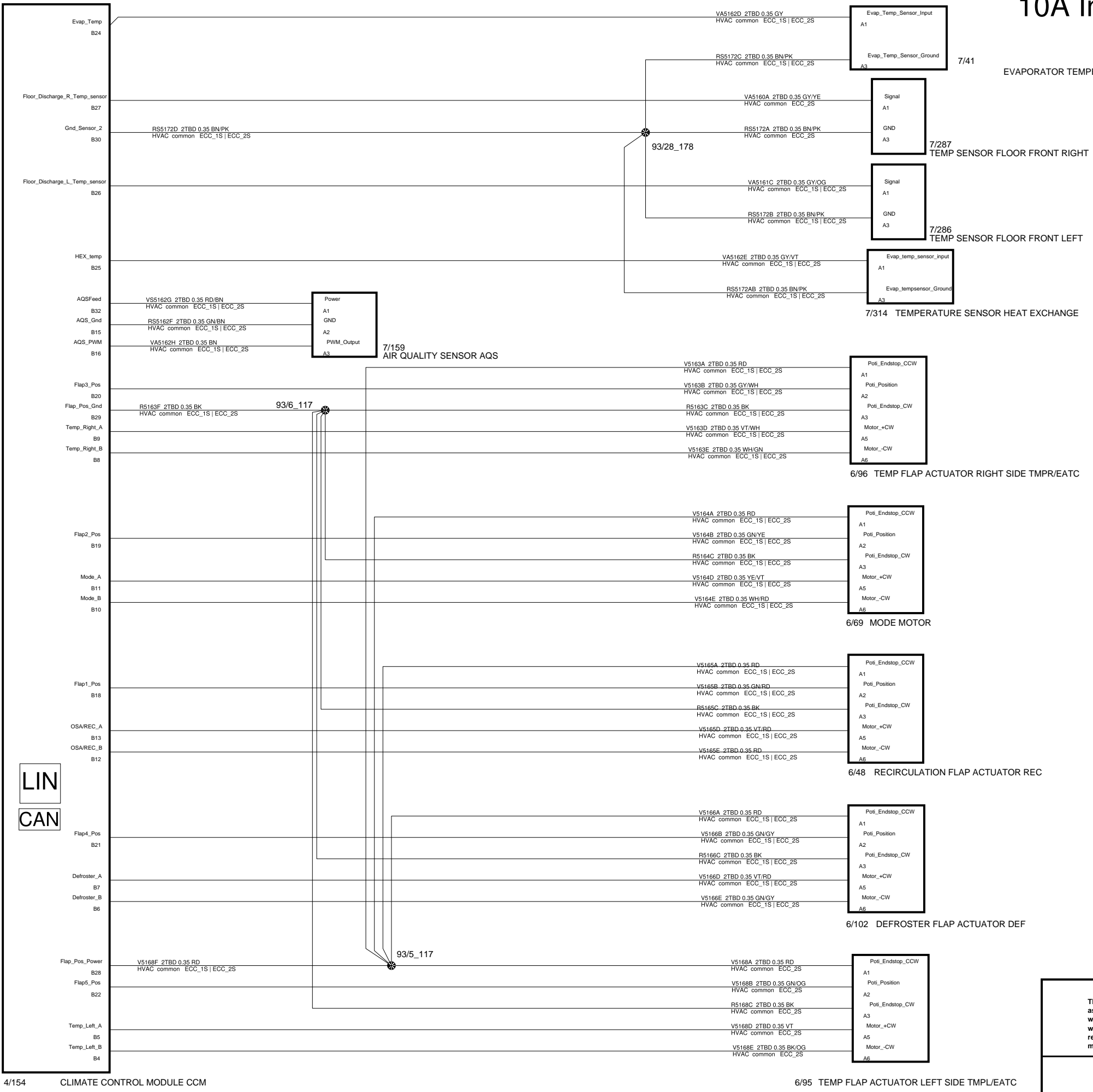

LIN  
CAN

<p>The copying, distribution and utilization of this document as well as the communication of its contents to others without expressed authorization is prohibited. Offenders will be held liable for payment of damages. All rights reserved in the event of the grant of a patent, utility model or ornamental design registration.</p> <p><b>VOLVO</b> VOLVO CAR CORPORATION</p>		<p><b>Document title</b> CMA_622A_CC_All_5_30 10A_Interior_HVAC_Harness_VCC_2-ZONES_ECC</p>	
		<p><b>Document Type</b> DRAW/ELSY</p>	<p><b>Release Status</b> RELEASED</p>
		<p>Volvo Document No 33445458</p>	<p><b>Edited</b> June/16/2021</p>
		<p><b>Issue</b> 030</p>	<p><b>Page No</b> 144/149</p>

4/154 CLIMATE CONTROL MODULE CCM

6/95 TEMP FLAP ACTUATOR LEFT SIDE TMLP/EATC

# 10A Internal 7DCT Harness

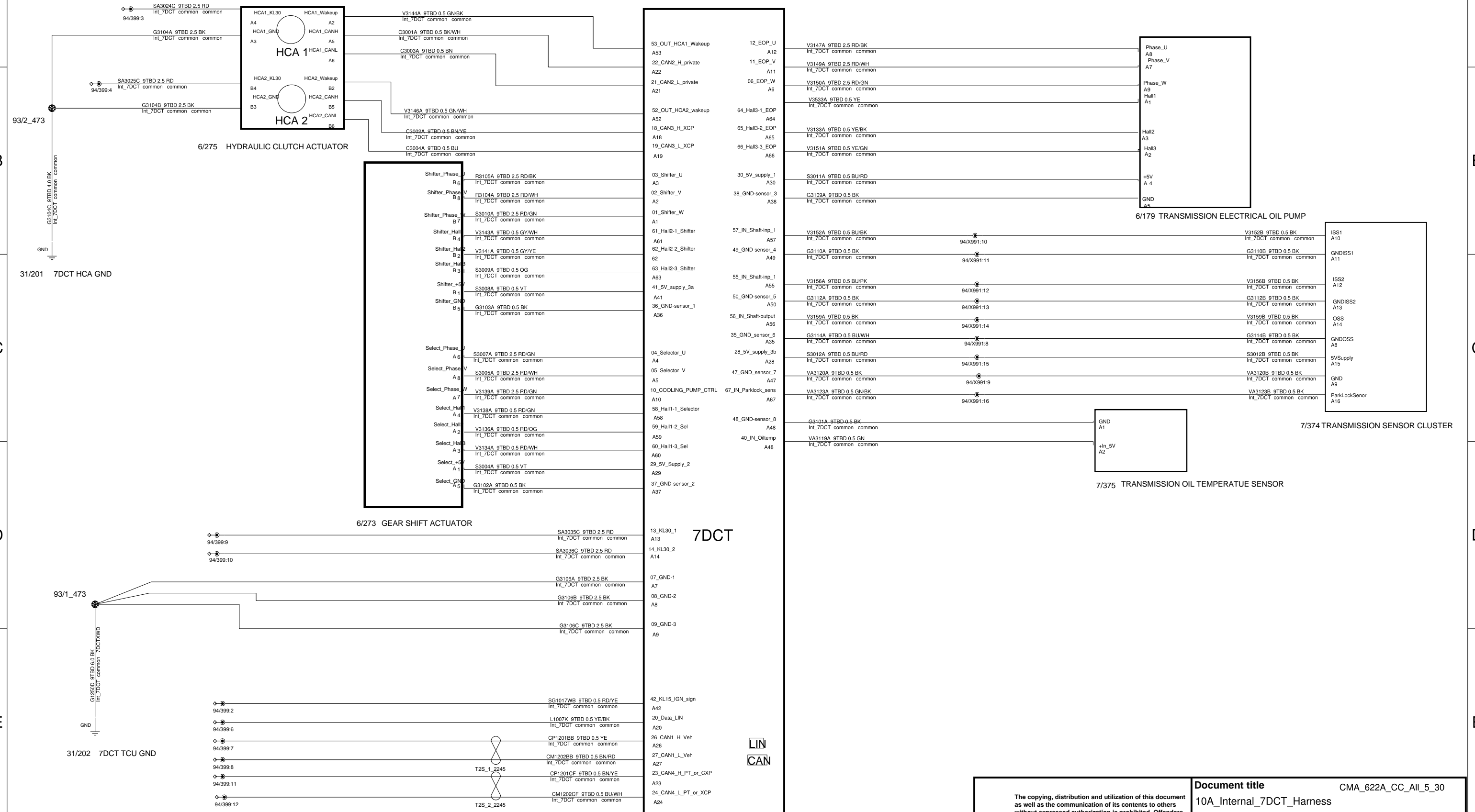

<p>The copying, distribution and utilization of this document as well as the communication of its contents to others without expressed authorization is prohibited. Offenders will be held liable for payment of damages. All rights reserved in the event of the grant of a patent, utility model or ornamental design registration.</p>		<b>Document title</b> CMA_622A_CC_All_5_30 10A_Internal_7DCT_Harness	
		<b>Document Type</b> DRAW/ELSY	<b>Release Status</b> RELEASED
 VOLVO CAR CORPORATION		CEVT Document No 8888522365	<b>Edited</b> February/18/2022
		<b>Issue</b> 030	<b>Page No</b> 145/149

# 10A Passenger Seat Internal Harness High LHD

SERVICE CONNECTOR

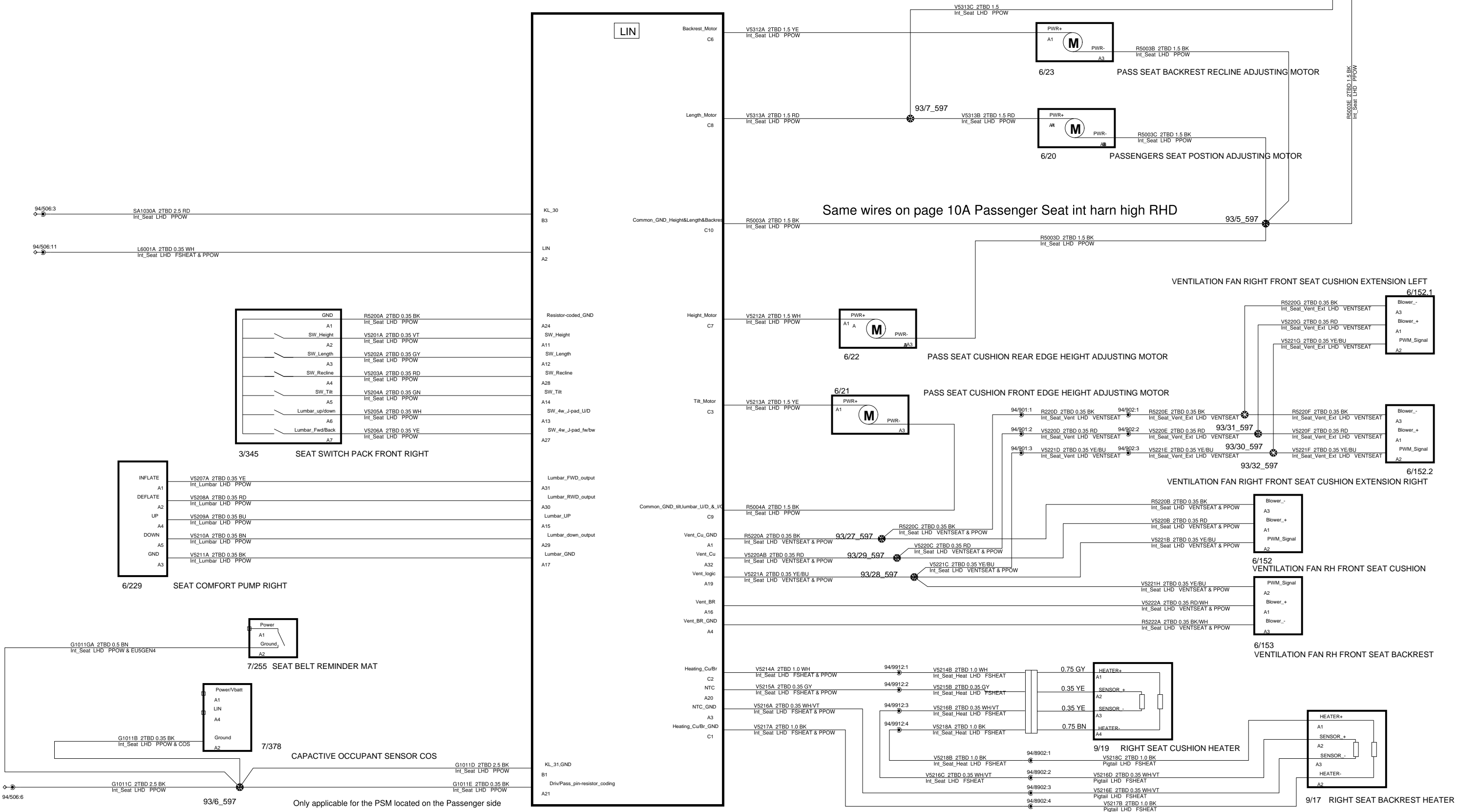

Same wires on page 10A Passenger Seat int harn high RHD

Terminal	Wire	Color	Component
A1	R5200A	2TBD 0.35 BK	Resistor-coded_GND
A2	V5201A	2TBD 0.35 VT	SW_Height
A3	V5202A	2TBD 0.35 GY	SW_Length
A4	V5203A	2TBD 0.35 RD	SW_Recline
A5	V5204A	2TBD 0.35 GN	SW_Tilt
A6	V5205A	2TBD 0.35 WH	Lumbar_up/down
A7	V5206A	2TBD 0.35 YE	Lumbar_Fwd/Back

Terminal	Wire	Color	Component
A1	V5207A	2TBD 0.35 YE	INFLATE
A2	V5208A	2TBD 0.35 RD	DEFLATE
A4	V5209A	2TBD 0.35 BU	UP
A5	V5210A	2TBD 0.35 BN	DOWN
A3	V5211A	2TBD 0.35 BK	GND

Terminal	Wire	Color	Component
A1	Power		7/255 SEAT BELT REMINDER MAT
A2	Ground		

Terminal	Wire	Color	Component
A1	Power/Vbatt		7/378 CAPACITIVE OCCUPANT SENSOR COS
A2	Ground		

The copying, distribution and utilization of this document as well as the communication of its contents to others without expressed authorization is prohibited. Offenders will be held liable for payment of damages. All rights reserved in the event of the grant of a patent, utility model or ornamental design registration.

**VOLVO**  
VOLVO CAR CORPORATION

<b>Document title</b> CMA_622A_CC_All_5_30 10A_Passenger_Seat_Internal_Harness_High_LHD	
<b>Document Type</b> DRAW/ELSY	<b>Release Status</b> RELEASED
Volvo Document No 33445458	<b>Edited</b> March/03/2022
<b>Issue</b> 030	<b>Page No</b> 146/149

Only applicable for the PSM located on the Passenger side

4/277.1 SEAT MODULE RIGHT SMR

# 10A Passenger Seat Internal Harness High RHD

SERVICE CONNECTOR

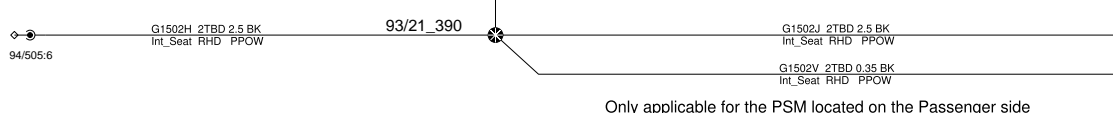
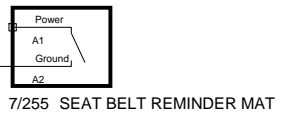
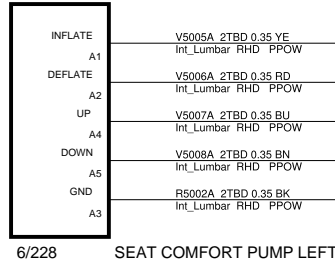
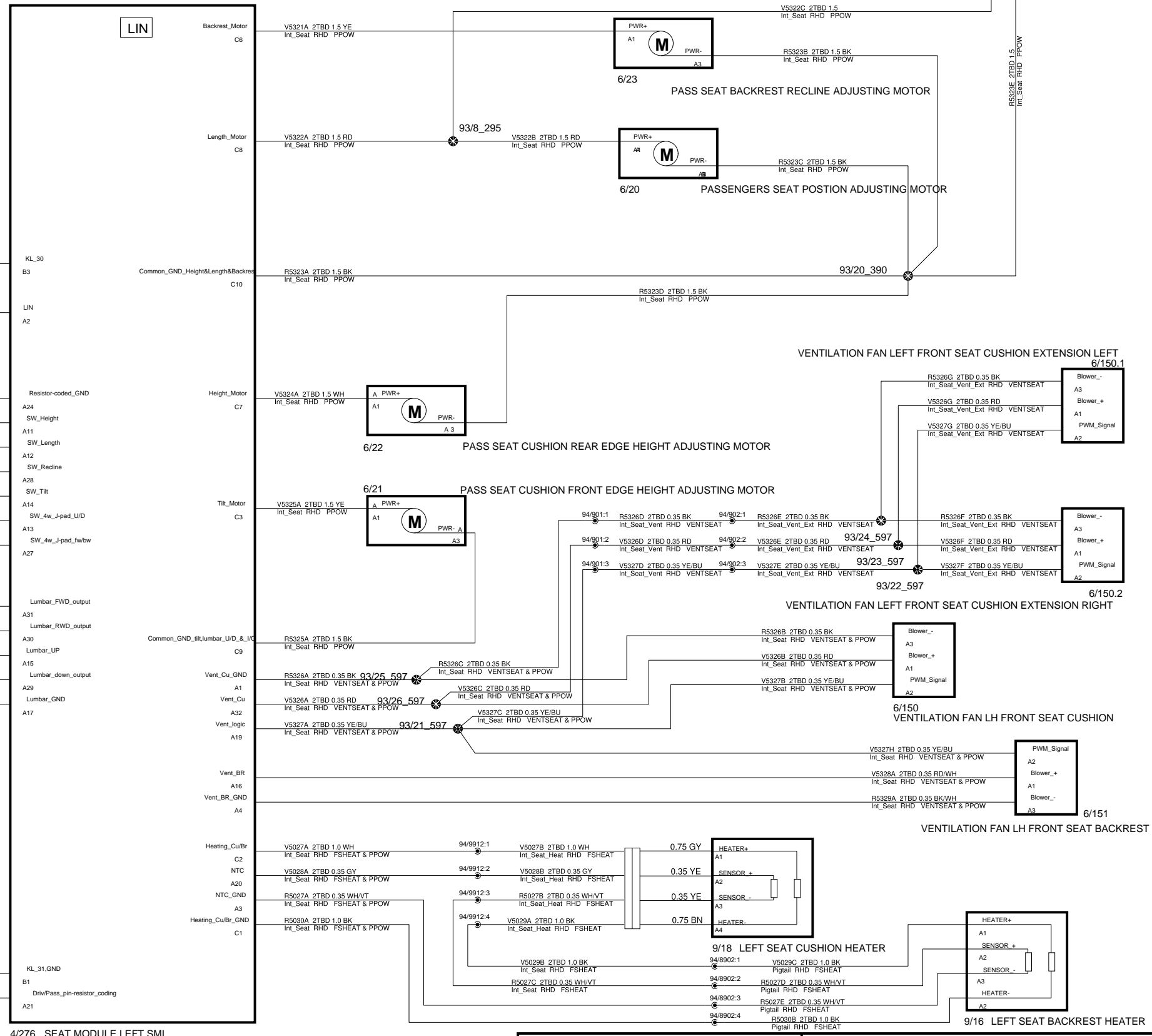

Only applicable for the PSM located on the Passenger side

The copying, distribution and utilization of this document as well as the communication of its contents to others without expressed authorization is prohibited. Offenders will be held liable for payment of damages. All rights reserved in the event of the grant of a patent, utility model or ornamental design registration.

**VOLVO**  
VOLVO CAR CORPORATION

Document title		CMA_622A_CC_All_5_30	
10A_Passenger_Seat_Internal_Harness_High_RHD			
Document Type	Release Status		
DRAW/ELSY	RELEASED		
Volvo Document No		Edited	
33445458		March/03/2022	
Issue	Page No		
030	147/149		

# 10A Passenger Seat Internal Harness Mech LHD

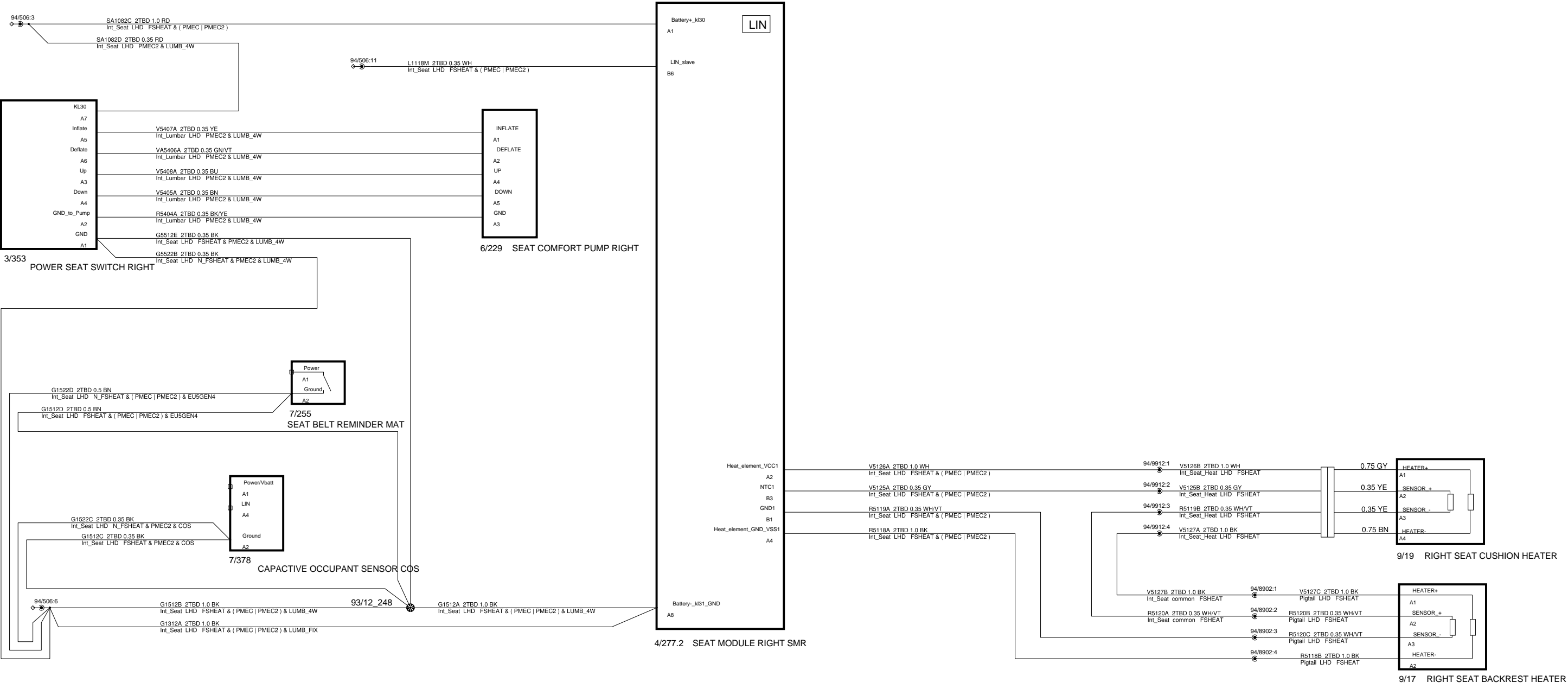

<p>The copying, distribution and utilization of this document as well as the communication of its contents to others without expressed authorization is prohibited. Offenders will be held liable for payment of damages. All rights reserved in the event of the grant of a patent, utility model or ornamental design registration.</p> <p><b>VOLVO</b> VOLVO CAR CORPORATION</p>	<p><b>Document title</b> CMA_622A_CC_All_5_30 10A_Passenger_Seat_Internal_Harness_Mech_LHD</p>	
	<p><b>Document Type</b> DRAW/ELSY</p>	<p><b>Release Status</b> RELEASED</p>
	<p>Volvo Document No 33445458</p>	<p><b>Edited</b> March/03/2022</p>
	<p><b>Issue</b> 030</p>	<p><b>Page No</b> 148/149</p>

# 10A Passenger Seat Internal Harness Mech RHD

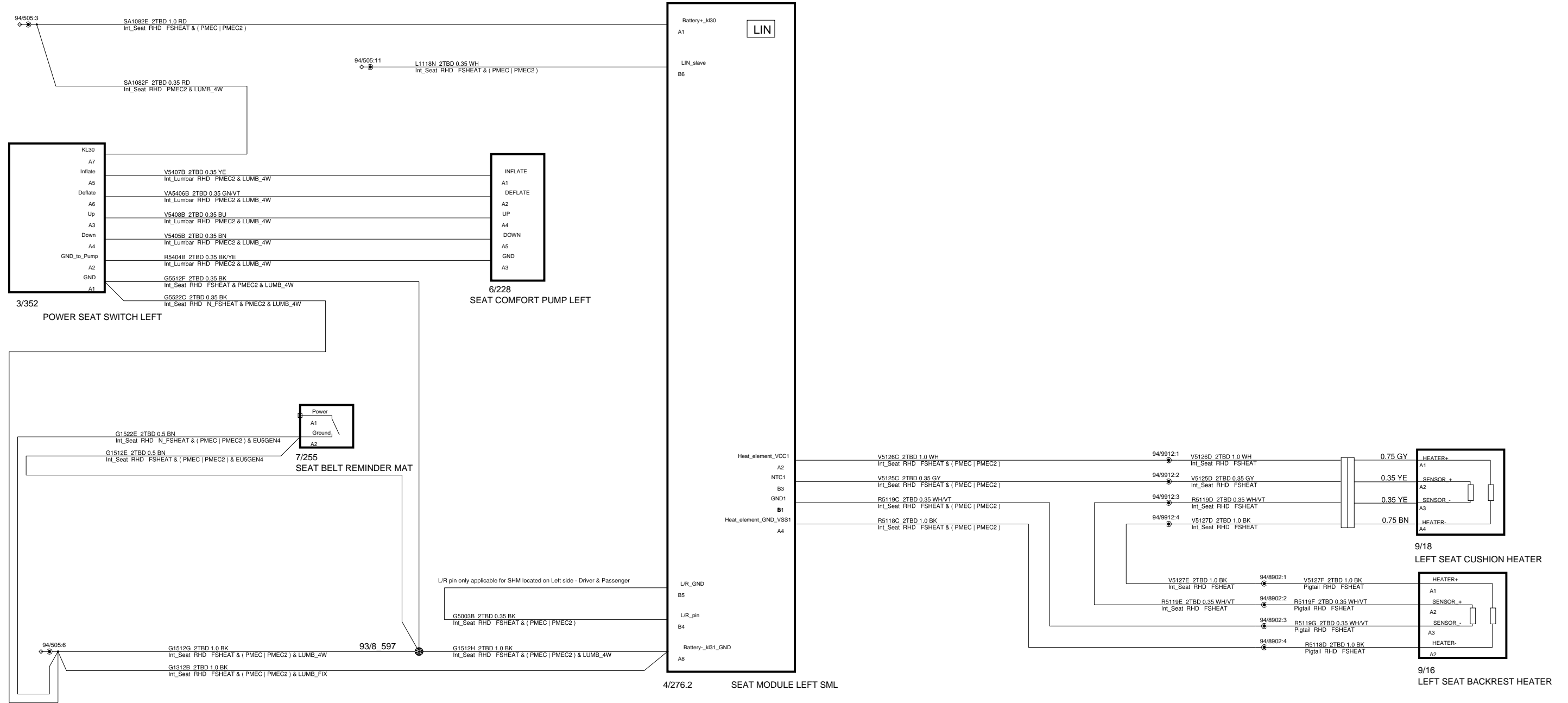

<p>The copying, distribution and utilization of this document as well as the communication of its contents to others without expressed authorization is prohibited. Offenders will be held liable for payment of damages. All rights reserved in the event of the grant of a patent, utility model or ornamental design registration.</p> <p><b>VOLVO</b> VOLVO CAR CORPORATION</p>	<b>Document title</b> CMA_622A_CC_All_5_30 10A_Passenger_Seat_Internal_Harness_Mech_RHD	
	<b>Document Type</b> DRAW/ELSY	<b>Release Status</b> RELEASED
	Volvo Document No 33445458	<b>Edited</b> March/03/2022
	<b>Issue</b> 030	<b>Page No</b> 149/149