

# News Channel Update | Vans Customer Service and Parts

TO: Freightliner Dealer Principals, General Managers, Sales Managers, Service Managers, Parts Managers	FROM: Anthony Washington, Department Manager, Regulations and Certifications
<b>Re: Service Campaign Notification Model 907 (Sprinter) Model Year 2019-2020 Retrofit Propeller Shaft Holder Bracket</b>	DATE: June, 2022

## IMPORTANT SERVICE CAMPAIGN INFORMATION



# News Channel Update | Vans Customer Service and Parts

Campaign No. :	Campaign	Retrofit Propeller Shaft Holder Bracket	
2022050016	VS3TR61EWE		
This is to notify you of the upcoming <b>Service Campaign</b> to Retrofit the Propeller Shaft Holder Bracket on approximately 46 MY20-21 Freightliner Sprinter vans. All affected VINs will be flagged as "OPEN" in VMI.			
<b>Background</b>			
<b>Issue</b>	Mercedes-Benz AG, the manufacturer of Freightliner Sprinter vehicles, determined that holder brackets welded onto the cross member for the propeller shaft intermediate bearing may be missing on certain vehicles. As a result, the propeller shaft intermediate bearing may not have been installed at the specified position.		
<b>What We're Doing</b>	DVUSA is conducting a service campaign. An authorized Freightliner Sprinter dealer will inspect affected vehicles and retrofit the bracket if it is not present.		
<b>Parts</b>	Parts are available.		
<b>Vehicles Affected</b>			
<b>Vehicle Model Year(s)</b>	Model Year 2019-2020		
<b>Vehicle Model</b>	Sprinter, VS30 / Platform 907		
<b>Vehicle Populations</b>			
<b>Total Vehicles</b>	46		
<b>Dealer Inventory</b>	0		
<b>Next Steps/Notes</b>			
<b>AOMS/SOMS</b>	Please ensure your dealers have read and understand this notice.		
While we regret any inconvenience this may cause, DVUSA is determined to maintain a high level of vehicle quality and customer satisfaction.			

Daimler Vans USA, LLC

A Mercedes-Benz Group AG Company

One Mercedes-Benz Drive Sandy Springs, GA 30328 770.705.0600

# Service Campaign Bulletin

Service Campaign Bulletin

Service Campaign Bulletin

Campaign No. 2022050016 June, 2022

TO: ALL MERCEDES-BENZ & FREIGHTLINER CENTERS

SUBJECT: **Model 907 Model Year 2019-2020  
Retrofit Propeller Shaft Holder Bracket**

MBAG, the manufacturer of Mercedes-Benz Sprinter vehicles, determined that the holder brackets that are welded onto the cross member for the propeller shaft intermediate bearing may be missing on certain vehicles. As a result, the propeller shaft intermediate bearing may not have been installed at the specified position.

An authorized Mercedes-Benz Sprinter dealer will inspect affected vehicles and retrofit the bracket if it is not present.

Prior to performing this Service Campaign:

- Please check VMI to determine if the vehicle is involved in the Campaign and if it has been previously repaired.
- Please review the entire Service Campaign bulletin and follow the repair procedure exactly as described.

Approximately **370 MB & 46 FTL** Sprinter vehicles are affected.

Order No. V-SC-2022050016 This bulletin has been created and maintained in accordance with MBUSA-SLP S423QH001, Document and Data Control, and MBUSA-SLP S424HH001, Control of Quality Records.

Service Campaign Bulletin

Service Campaign Bulletin

Service Campaign Bulletin

- Model 907**  
with code IR6 (Wheelbase 4325 mm, overhang 1615 mm)  
with code ZU7 (National version for Canada)
- Model 907**  
with code IR6 (Wheelbase 4325 mm, overhang 1615 mm)  
with code ZU8 (National version for USA)
- Model 907**  
with code IR7 (Wheelbase 4325 mm, overhang 2015 mm)  
with code ZU7 (National version for Canada)
- Model 907**  
with code IR7 (Wheelbase 4325 mm, overhang 2015 mm)  
with code ZU8 (National version for USA)

**Operation no. of the operation texts or standard texts and flat rates**





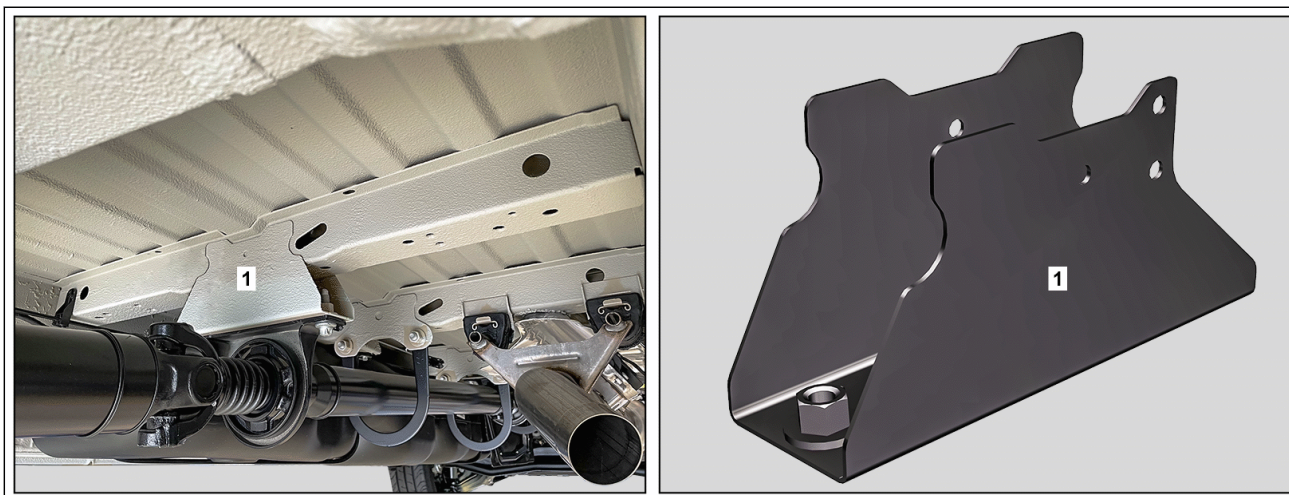



Category	Op. no.	Operation text	Time	Damage Code	Code
L	02 0610	Operations: Retrofit holder for propeller shaft on crossmember on underbody	3.4 hrs	61 920 01	VS3TR61E WE
L	02 3282	Operations: Remove underfloor paneling (when working on veh.)	0.2 hrs	61 920 01	VS3TR61E WE
L	02 1144	Operations: Empty/fill fuel tank, observe accident prevention regulations (when working on veh.)	<1.0 hrs	61 920 01	VS3TR61E WE

**\*for Inspection only, the workshop should use code 02-0001 and claim 0.1hr**









1 Bracket

D41.10-A028-78

 <b>Danger</b>	The high voltage used for electric welding presents a lethal hazard. <b>Risk of explosion</b> from welding in areas close to highly inflammable materials. <b>Risk of injury</b> from weld splatter and UV-light when welding. <b>Risk of poisoning</b> from inhaling welding gases	Use insulating mats. Wear protective clothing, safety glasses and a protective mask. Remove highly inflammable materials from the hazard area. Use air extraction system.	AS00.00-Z-0007-01A
 <b>Danger</b>	<b>Risk of death</b> caused by vehicle slipping or toppling off of the lifting platform.	Align vehicle between vehicle lift columns and position the four support plates at the vehicle lift support points specified by the vehicle manufacturer.	AS00.00-Z-0010-01A
 <b>Caution</b>	<b>Risk of injury</b> caused by scraping or cutting body parts on sharp vehicle parts	Always wear protective gloves when working on or near sharp and non-deburred vehicle parts. Deburr repair panels.	AS00.00-Z-0017-01A
<b>Notice</b>	Measures for preventing damage to vehicles or components when performing electric welding work		AH00.00-P-0005-01KOA
<b>Notice</b>	General information on body repair		AH60.00-P-0001-01KOA
	<b>Check</b>		
1	Check if vehicle is affected by measure.		
	<b>Remove</b>		
2  AR	Remove fuel tank.	Model 907 with engine 642, 651	AR47.10-D-4100TSR
3  AR	Remove propeller shaft.	 Replace propeller shaft.	AR41.10-D-0050TS
4	Cover all detachable parts remaining in vehicle with welding protection blankets.	 <b>Commercially available devices/ tools</b> Welding protection blanket	

	<b>Install</b>		
5  WS	Retrofit holder (1) for propeller shaft.  000 588 02 84 00 Welder	Clip: Retrofit holder for propeller shaft on crossmember   <b>Commercially available devices/ tools</b> Clamping pliers (Standard) Rotary wire brush Drill bit 7 mm Wet and dry vacuum cleaner	<a href="#">Page 9</a>  <a href="#">Page 5</a>  WS60.00-P-0022K
6	Clean weld joints and sheet metal flange.	 <b>Commercially available devices/ tools</b> Rotary wire brush	
7	Remove welding protection blankets.	 <b>Commercially available devices/ tools</b> Welding protection blanket	
8	Clean repair area.	 <b>Commercially available devices/ tools</b> Wet and dry vacuum cleaner	
9 Notice	<b>Danger</b> <b>Risk of explosion</b> caused by paint vapors igniting. <b>Risk of poisoning</b> caused by inhaling paint vapors.  Prime repair area with primer filler. Notes on paintwork repairs	No smoking! No open fire! Use respiratory protection, protective clothing, gloves, safety glasses and protective skin cream. Ensure that the area is well ventilated.   Use only primer fillers approved by manufacturer. See guidelines for paint technology in the workshop portal.	AS98.00-Z-0002-01A  AH98.00-P-9408-02A

10	 <b>Danger</b>	<b>Risk of explosion</b> caused by paint vapors igniting. <b>Risk of poisoning</b> caused by inhaling paint vapors.	No smoking! No open fire! Use respiratory protection, protective clothing, gloves, safety glasses and protective skin cream. Ensure that the area is well ventilated.	AS98.00-Z-0002-01A
	<b>Notice</b>	Paint repair area and adjacent surfaces using a brush or spray can.		AH98.00-P-9409-06A
	<b>Notice</b>	General notes on touch-up applicators and paint spray cans Notes on paintwork repairs	 Paint repair area with a spray can.  Use only paints approved by Daimler AG: <a href="http://xentryportal.mercedes-benz.com">http://xentryportal.mercedes-benz.com</a>	AH98.00-P-9408-02A
11	 <b>AR</b>	Add underbody protection to crossmember in area of repair point. Processing permanent underbody protection for painting	Underfloor protection 800 ml Underfloor protection, synthetic rubber 1 l	AR97.20-D-0500-03TS <a href="#">BR00.45-Z-1001-05A</a> <a href="#">BR00.45-Z-1012-05A</a>
12	 <b>AR</b>	Add cavity preservation in crossmember on underbody.		AR97.20-D-1500TS
13	 <b>AR</b>	Install new propeller shaft.		AR41.10-D-0050TS
14	 <b>AR</b>	Install fuel tank.	Model 907 with engine 642, 651	AR47.10-D-4100TSR

#### Repair materials

Number	Designation	Order number
BR00.45-Z-1001-05A	Underfloor protection 800 ml	A 001 986 46 10
BR00.45-Z-1012-05A	Underfloor protection, synthetic rubber 1 l	A 000 989 20 21

#### Parts ordering note

Part no.	Designation	Quantity
A 906 310 09 09	Propeller shaft holder	1
	Propeller shaft (see XENTRY Parts Information)	1

SM41.10-D-0030-02SG	Weld holder for propeller shaft to crossmember (code: VS3TR61EWE, acc. no.: 61 920 01)		
 WS	000 588 02 84 00 Welder		WS60.00-P-0022K

**Model 907**  
**with code IR6 (Wheelbase 4325 mm, overhang 1615 mm)**  
**with code ZU7 (National version for Canada)**

**Model 907**  
**with code IR6 (Wheelbase 4325 mm, overhang 1615 mm)**  
**with code ZU8 (National version for USA)**

**Model 907**  
**with code IR7 (Wheelbase 4325 mm, overhang 2015 mm)**  
**with code ZU7 (National version for Canada)**

**Model 907**  
**with code IR7 (Wheelbase 4325 mm, overhang 2015 mm)**  
**with code ZU8 (National version for USA)**



Refer to the superordinate service document for further information.

Observe safety information in the superordinate service document.

- 1 Make markings for holes (A<sub>1</sub>, A<sub>2</sub>, A<sub>3</sub>, B<sub>1</sub> and B<sub>2</sub>), as shown.



When doing so, maintain a distance of approx. 10 mm from edge of holder (1) for outer markings.

- 2 Drill holes (A<sub>1</sub>, A<sub>2</sub>, A<sub>3</sub>, B<sub>1</sub> and B<sub>2</sub>) into holder (1) with  $\varnothing$  7 mm.



**Commercially available devices/tools**

Hand drill

- 3 Grind cross-hatched areas around holes (A<sub>1</sub>, A<sub>2</sub>, A<sub>3</sub>, B<sub>1</sub> and B<sub>2</sub>) down to bare metal.



**Commercially available devices/tools**

Rotary wire brush

- 4 Remove grinding dust and drill chips.



**Commercially available devices/tools**

Wet and dry vacuum cleaner

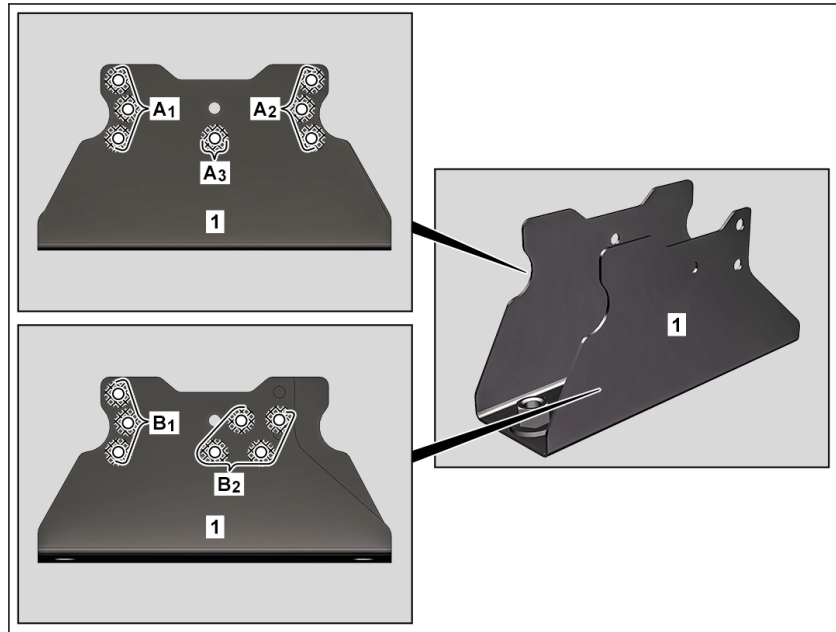

D41.10-A029-76

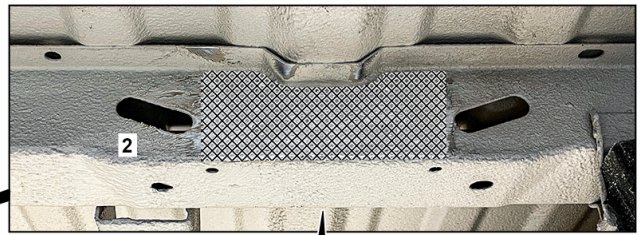
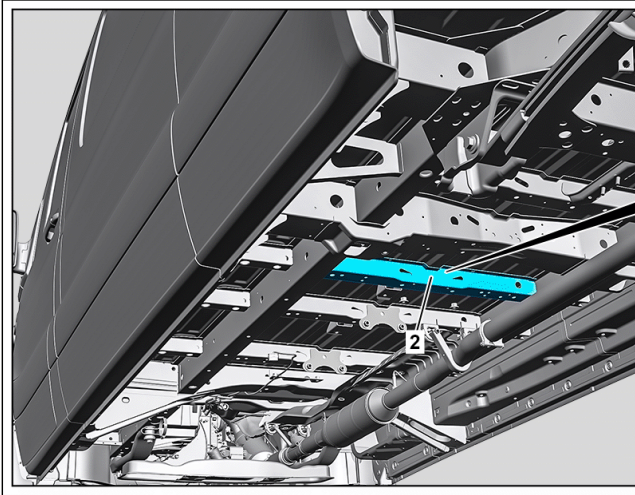

D41.10-A030-78

- 5 Remove underbody protection in cross-hatched areas from crossmember (2).



**Commercially available devices/tools**

Rotary wire brush

- 6 Grind cross-hatched areas down to bare metal on crossmember (2).



**Commercially available devices/tools**

Rotary wire brush

- 7 Remove grinding dust.



**Commercially available devices/tools**

Wet and dry vacuum cleaner

- 8 Attach holder (1) to crossmember (2), line up then fix in place.



Observe dimensions (A, B).

Dimension (a) is 5 mm.

Dimension (b) is 10 mm.

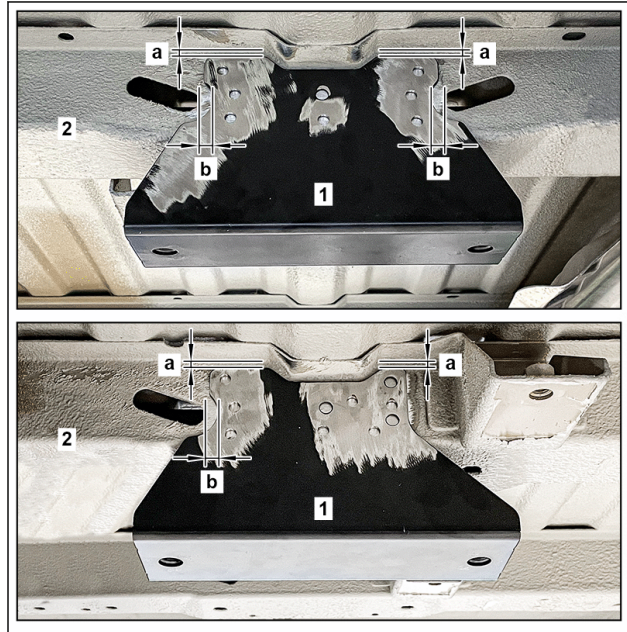

D41.10-A032-82

- 9 Holder (1)  $\text{sa}$  (areas C1, C2, C3, D1 and D2).



The holder (1) must lie flush on the crossmember (2) without any gap.

- 10 Clean weld joints and sheet metal flange.



**Commercially available devices/tools**

Rotary wire brush

- 11 Remove grinding dust.



**Commercially available devices/tools**

Wet and dry vacuum cleaner

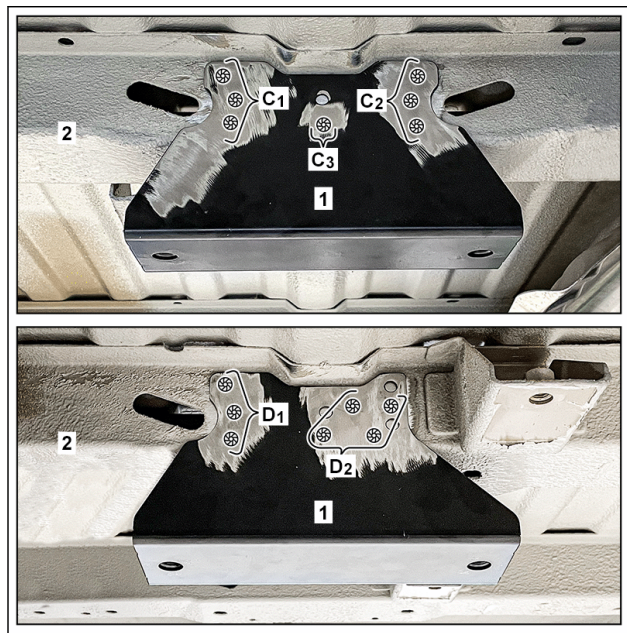

D41.10-A031-82