

**WLN3 – Replacing Starter (Workshop Campaign)**

Revision: This bulletin replaces bulletin Group 2 70/21 WLN3, dated March 28, 2022.

Model Year: **As of 2018 up to 2019**

Vehicle Type: **Cayenne (9YA)**

Market: **USA (C02)  
Canada (C36)**

Concerns: **Starter**

Information: **The affected vehicles may have been installed with a starter on which the threaded joint for the end cover can come loose and this can cause the starter to fail.**

As a result, the vehicle might not start.

Action required: Replace starter.



**Information**

Please note that different parts are required for carrying out the campaign on the affected vehicles. **Every vehicle** is assigned just **one campaign scope**.

⇒ To find out which scope is assigned to the vehicle, see PCSS Vehicle Information.

Affected Vehicles: Only vehicles assigned to the campaign (see also PCSS Vehicle Information).

Installation  
Position:

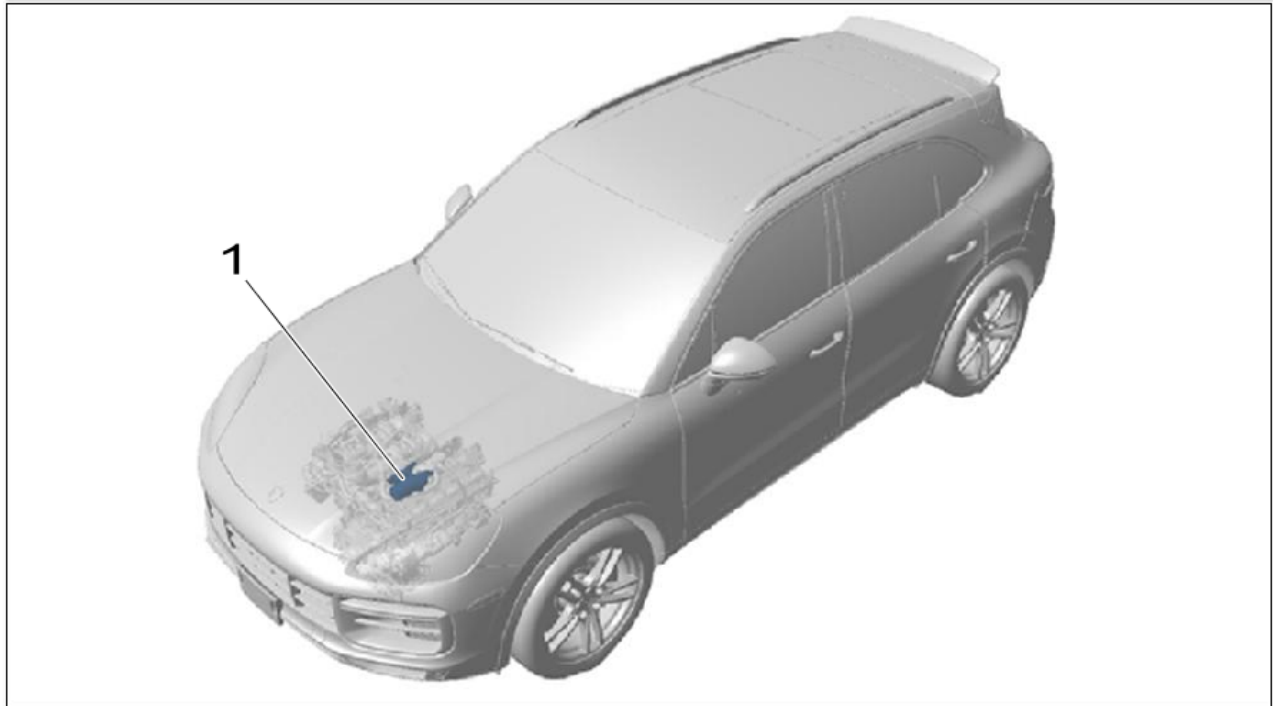

*Installation position of starter*

**1** – Starter (replace)

### Required parts and materials

Parts Info: **Vehicles with assigned campaign scope 3**

Part No.	Designation – Location	Qty.
V04015001BJ	⇒ Starter	1 ea.
N 10314506	⇒ Hexagon flange bolt, M10 x 50 – Starter	1 ea.
PAF911296	⇒ Bihexagonal head bolt – Starter	1 ea.
N 10742702	⇒ Internal hexagon round/oval-head screw, M8 x 25 – Belt tensioner	2 ea.
PAF00072900	⇒ Hexagon socket head bolt, M8 x 20 – Engine guard or front underbody cover	3 ea.
9A700837900	⇒ Tie-wrap	2 ea.

Parts Info: **Vehicles with assigned campaign scope 4**

Part No.	Designation - Location	Qty.
V04015001BJ	⇒ Starter	1 ea.
N 10314506	⇒ Hexagon flange bolt, M10 x 50 - Starter	1 ea.
PAF911296	⇒ Bihexagonal head bolt - Starter	1 ea.
N 10742702	⇒ Internal hexagon round/oval-head screw, M8 x 25 - Belt tensioner	2 ea.
PAF00072900	⇒ Hexagon socket head bolt, M8 x 20 - Engine guard or front underbody cover	3 ea.
9A700837900	⇒ Tie-wrap	2 ea.
PAF82595100	⇒ Screw, M6 x 20 - Front underbody cover	2 ea.

Materials: **Required materials** (usually already available at the Porsche dealer):

Part No.	Designation - Location	Qty.
D 00940104	⇒ Cleaning solution or alternative (commercially available) - Locking element in converter area	250 ml/ 8.45 fl oz container (approx. 100 ml/ 3.38 fl oz required per vehicle)*
00004330532	⇒ Sealing compound - Locking element in converter area	300 ml/ 10.14 fl oz container (approx. 5 ml/ 0.17 fl oz required per vehicle)

\*For warranty processing, the cleaning solution can be invoiced either under the part number or under Part No. **WLN30000001** with the "expendable items" designation as an **additional part** in the warranty claim.

## Required tools

- Tools:
- **T10384 - Ratchet wrench, a/f 13**
  - **VAS 6928 - Socket set, 39-piece**
  - **10-222A - Support bracket**
  - **VAS 6931 - Engine and gearbox jack**
  - **Tension strap**

## Preparatory work

- Work Procedure: 1 Disconnect the battery. ⇒ *Workshop Manual '2X00IN Work instructions after disconnecting the battery'*
- 2 Remove belt tensioner. ⇒ *Workshop Manual '2X00IN Removing and installing drive belt (V6 Turbo)'*
- 3 Remove generator. ⇒ *Workshop Manual '272219 Removing and installing generator (V6 Turbo)'*
- 4 Remove heat shield ⇒ *Heat shield for front-axle carrier -3-*.
- 4.1 Unscrew screws ⇒ *Heat shield for front-axle carrier -1 and 2-* and guide out heat shield ⇒ *Heat shield for front-axle carrier -3-*.
- 5 Remove right catalytic converter. ⇒ *Workshop Manual '267319 Removing and installing catalytic converter (V6 biturbo)'*
- 6 Remove engine mount (supporting mount). ⇒ *Workshop Manual '103519 Removing and installing engine mount (supporting mount) (V6 Turbo)'*
- 7 Remove right engine mount. ⇒ *Workshop Manual '103519 Removing and installing engine mounts (V6 Turbo)'*
- 8 Remove right engine support ⇒ *Right engine support (shown on V8) -1-*.
- 8.1 Unscrew screws ⇒ *Right engine support (shown on V8) -2-*.
- 8.2 Remove right engine support ⇒ *Right engine support (shown on V8) -1-*.

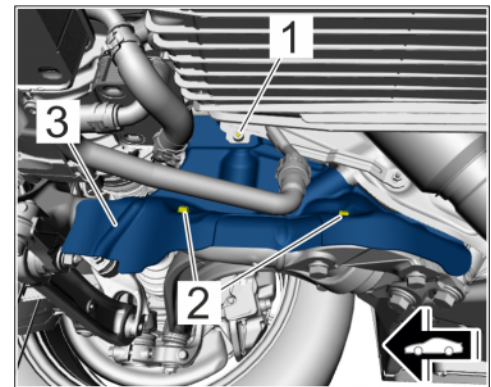

*Heat shield for front-axle carrier*

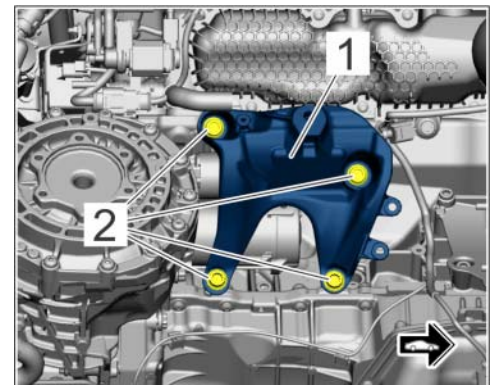

*Right engine support (shown on V8)*

## Replacing starter (campaign scope 3-6)

**⚠ WARNING**

Danger of objects or loads falling down

- Risk of squashing or crushing
- ⇒ Secure components to prevent them from falling down.

**⚠ CAUTION**

Hot components

- Risk of burns
- ⇒ Let hot components cool down.
- ⇒ Wear personal protective gear.

Work Procedure: 1 Loosen wire harness for starter ⇒ *Wire harness for starter -1-* from the holder.

1.1 Cut tie-wraps ⇒ *Wire harness for starter -2-*.

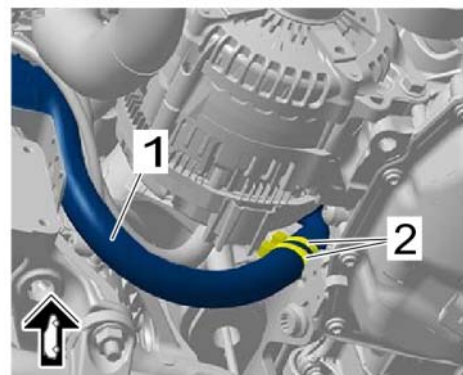

*Wire harness for starter*

2 Disconnect starter from engine wire harness.

2.1 Position the starter in such a way that the electric plug connection ⇒ *Electric lines for starter -1-* and nut ⇒ *Electric lines for starter -2-* are accessible.

2.2 Secure the starter to prevent it from falling down.

2.3 Release and disconnect electric plug connection ⇒ *Electric lines for starter -1-*.

2.4 Screw off nut ⇒ *Electric lines for starter -2-* and remove B+ line ⇒ *Electric lines for starter -3-* from the starter.

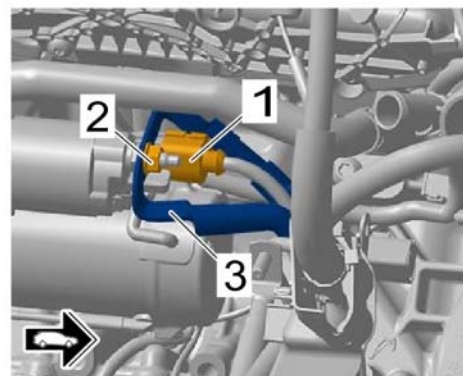

*Electric lines for starter*

- 3 Remove the starter ⇒ *Starter screws -1-*.
  - 3.1 Unscrew screws ⇒ *Starter screws -2-* and ⇒ *Starter screws -3-*.
  - 3.2 Remove and replace the starter ⇒ *Starter screws -1-*.

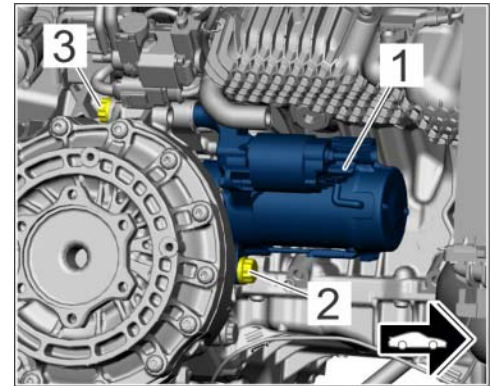

Starter screws

- 4 Remove locking element in converter area ⇒ *Locking element in converter area -1-*.
  - 4.1 Clean locking element in converter area ⇒ *Locking element in converter area -1-* and the surface of the crankcase ⇒ *Locking element in converter area -2-* carefully with cleaner (Part No. D00940104).
  - 4.2 Coat the surface of the crankcase ⇒ *Locking element in converter area -2-* and the opposite piece of the locking element in the converter area ⇒ *Locking element in converter area -1-* with some sealing compound (Part No. 00004330532).
  - 4.3 Position the locking element in the converter area ⇒ *Locking element in converter area -1-* and let the sealing compound dry off.

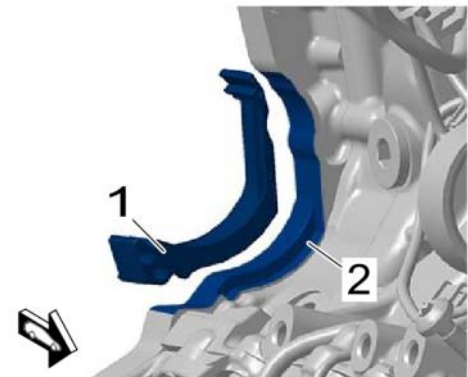

Locking element in converter area

- 5 Install **new** starter ⇒ *Starter screws -1-*.
  - 5.1 Install and tighten screws ⇒ *Starter screws -2- and 3-*.
 

Screw ⇒ *Starter screws -2-*: **Tightening torque 65 Nm (48ftlb.)**

Screw ⇒ *Starter screws -3-*:  
**Initial tightening 30 Nm (22 ftlb.)**  
**Final tightening +105°**

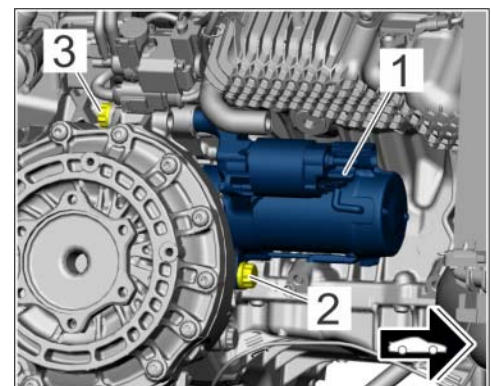

Starter screws

- 6 Connect starter to engine wire harness.
  - 6.1 Connect and lock electric plug connection ⇒ *Electric lines for starter -1-*.
  - 6.2 Install B+ line ⇒ *Electric lines for starter -3-* on the starter and tighten the nut ⇒ *Electric lines for starter -2-*.

**Tightening torque 20 Nm (15 ftlb.)**

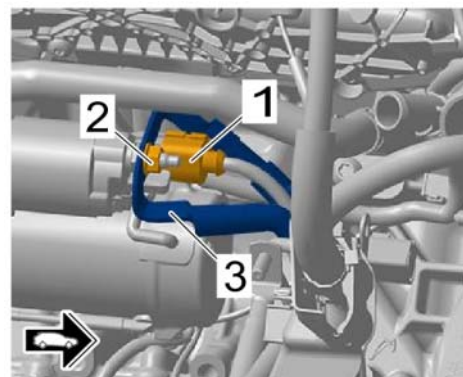

*Electric lines for starter*

- 7 Secure wire harness for starter ⇒ *Wire harness for starter -1-* to the holder.
  - 7.1 Position wire harness for starter ⇒ *Wire harness for starter -1-* and secure with **new** tie-wraps ⇒ *Wire harness for starter -2-*.

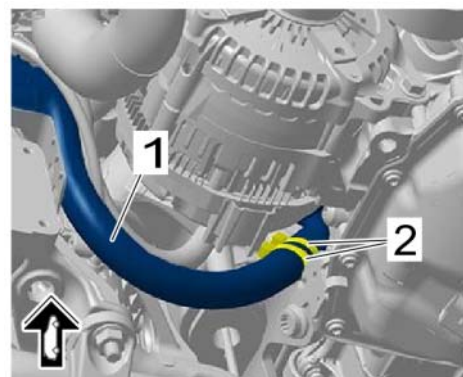

*Wire harness for starter*

**Concluding work**

- Work Procedure: 1 Install right engine support ⇒ *Right engine support -1-*.
  - 1.1 Tighten screws ⇒ *Right engine support -2-*.

**Tightening torque 55 Nm (41 ftlb.)**

- 2 Install right engine mount. ⇒ *Workshop Manual '103519 Removing and installing engine mounts (V6 Turbo)'*
- 3 Install engine mount (supporting mount). ⇒ *Workshop Manual '103519 Removing and installing engine mount (supporting mount) (V6 Turbo)'*
- 4 Install right catalytic converter. ⇒ *Workshop Manual '267319 Removing and installing catalytic converter (V6 biturbo)'*

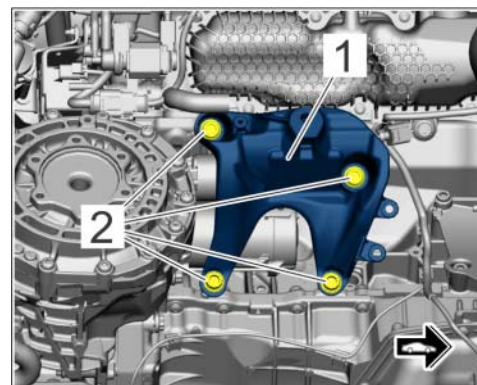

*Right engine support*

5 Install heat shield ⇒ *Heat shield for front-axle carrier -2-*.

5.1 Insert heat shield ⇒ *Heat shield for front-axle carrier -3-* and install and tighten screws ⇒ *Heat shield for front-axle carrier -1 and 2-*.

Screw ⇒ *Heat shield for front-axle carrier -1-*:  
**Tightening torque 9 Nm (6.5 ftlb.)**

Screw ⇒ *Heat shield for front-axle carrier -2-*:  
**Tightening torque 9 Nm (6.5 ftlb.)**

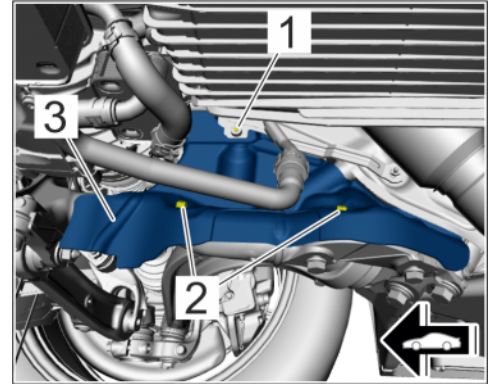

*Heat shield for front-axle carrier*

6 Install generator. ⇒ *Workshop Manual '272219 Removing and installing generator (V6 Turbo)'*

7 Install belt tensioner. ⇒ *Workshop Manual '137319 Removing and installing belt tensioner (generator)'*

8 Connect the battery. ⇒ *Workshop Manual '2X00IN Work instructions after disconnecting the battery'*

**– End of action required –**

Enter the campaign in the Warranty and Maintenance booklet.

## Warranty processing

Scope 1–2: **Not relevant for this vehicle type.**

Scope 3:

### Replacing starter

- Relevant for **Cayenne (9YA)** with **protective plate for engine (1SF)**

#### Working time:

Replacing starter

Labor time: **377 TU**

Includes:

- Removing and installing catalytic converter
- Removing and installing engine mount
- Removing and installing heat shield
- Removing and installing generator
- Removing and installing front cover
- Removing and installing belt tensioner
- Connecting and disconnecting battery ground strap

#### Parts required:

V04015001BJ Starter

1 ea.



N 10314506	Hexagon flange bolt, M10 x 50	1 ea.
PAF911296	Bihexagonal head bolt	1 ea.
N 10742702	Internal hexagon round/oval-head screw, M8 x 25	2 ea.
PAF00072900	Hexagon socket head bolt, M8 x 20	3 ea.
9A700837900	Tie-wrap	2 ea.
<b>Required materials</b> (usually already available at the Porsche dealer):		
D 00940104	Cleaning solution	0.4 ea.
<b>or</b>		
WLN30000001*	Expendable items	0.4 ea.
00004330532	Sealing compound	0.04 ea.
* For warranty processing, enter the Part No. <b>WLN30000001</b> with the "expendable items" designation as an <b>additional part</b> costing \$6.25 in the warranty claim.		
⇒ <b>Damage Code WLN3 66 000 2</b>		

Scope 4:

**Replacing starter**

- Relevant for **Cayenne (9YA) without** protective plate for engine (**1SA**).

<b>Working time:</b>		
Replacing starter		Labor time: <b>377 TU</b>
Includes:	Removing and installing catalytic converter Removing and installing engine mount Removing and installing heat shield Removing and installing generator Removing and installing front cover Removing and installing belt tensioner Connecting and disconnecting battery ground strap	
<b>Parts required:</b>		
V04015001BJ	Starter	1 ea.
N 10314506	Hexagon flange bolt, M10 x 50	1 ea.
PAF911296	Bihexagonal head bolt	1 ea.
N 10742702	Internal hexagon round/oval-head screw, M8 x 25	2 ea.
PAF00072900	Hexagon socket head bolt, M8 x 20	3 ea.
9A700837900	Tie-wrap	2 ea.

PAF82595100	Screw, M6 x 20	2 ea.
<b>Required materials</b> (usually already available at the Porsche dealer):		
D 00940104	Cleaning solution	0.4 ea.
<b>or</b>		
WLN30000001*	Expendable items	0.4 ea.
00004330532	Sealing compound	0.04 ea.

\* For warranty processing, enter the Part No. **WLN30000001** with the "expendable items" designation as an **additional part** costing \$6.25 in the warranty claim.

⇒ **Damage Code WLN3 66 000 2**

**Important Notice:** Technical Bulletins issued by Porsche Cars North America, Inc. are intended only for use by professional automotive technicians who have attended Porsche service training courses. They are written to inform those technicians of conditions that may occur on some Porsche vehicles, or to provide information that could assist in the proper servicing of a vehicle. Porsche special tools may be necessary in order to perform certain operations identified in these bulletins. Use of tools and procedures other than those Porsche recommends in these bulletins may be detrimental to the safe operation of your vehicle, and may endanger the people working on it. Properly trained Porsche technicians have the equipment, tools, safety instructions, and know-how to do the job properly and safely. Part numbers listed in these bulletins are for reference only. The work procedures updated electronically in the Porsche PIWIS diagnostic and testing device take precedence and, in the event of a discrepancy, the work procedures in the PIWIS Tester are the ones that must be followed.

© 2022 Porsche Cars North America, Inc.