

**Airbag Warning Light Activated: Fault Code 1217 and/or 1218 in Airbag Control Unit Fault Memory**

Revision: This bulletin replaces bulletin Group 6, 11/04, dated July 28, 2020.

Model Year: **As of 2003 up to 2004**

Vehicle Type: **Cayenne/Cayenne S/Cayenne Turbo**

Concerns: **Side airbag**

Information: **- Airbag warning light activated in multi-function display,  
- Fault code 1217 and/or 1218 in fault memory of airbag control unit.**

Note: On the driver and passenger seat, contact difficulties can occur in the plug connection between the side airbag and the wire harness.

When the fault type occurs, the airbag warning light is activated and fault code **1217** and/or **1218** is stored with the fault type "**Upper limit value exceeded**" in the fault memory of the airbag control unit.

Action Required: In the event of a complaint, the side airbag plug connection must be removed on **both front seats** and replaced by a crimp cable connection.

Tools: **Nr.155-2 - Repair kit for wiring harnesses/ TKR WEB-KIT-000001** (the following will be needed: 2x cable connections from compartment 4/1; 2x shrink-fit hoses with fusible plug from compartment 4/3)

Cloth adhesive tape or insulating tape

Clean cloth/surface (approx. 100 x 100 cm)

Tie-wraps

Hot-air gun

**9588 - Porsche System Tester II or 9718 - PIWIS Tester**

Work Procedure: Remove the side airbag plug connection on both front seats and replace with a crimp cable connection. To do this, the front seats must be removed and reinstalled.



**Danger of injury and material damage when working on or in the airbag system.**

⇒ **The following procedure does not replace the information in the Workshop Manual and the warnings listed therein.**

1 **Introductory work****Information**

On vehicles with the individual equipment "additional battery", it is not necessary to disconnect the additional battery.

- 1.1 Remove driver's and passenger's seat. ⇒ *Workshop Manual '720119 Removing and installing front seat'*
- 1.2 Take the front seats out of the vehicle. Set the seats with backrest on a clean cloth or surface.

2 **Release the plug connection (driver's seat).**

- 2.1 Disengage the right tensioning strap of the backrest cover (⇒ *Figure 1 -Arrow A-*).

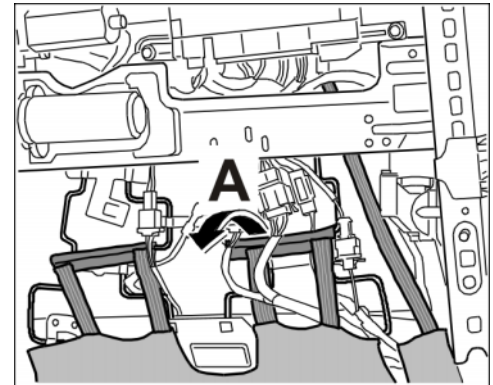

Figure 1

- 2.2 Push back lock on the side airbag plug (⇒ *Figure 2 -Arrow A-*) and remove from the plug socket on the side airbag (⇒ *Figure 2 -Arrow B-*).
- 2.3 Release side airbag plug at the seat frame (⇒ *Figure 2 -Arrow C-*) and push it out towards the front (⇒ *Figure 2 -Arrow D-*).
- 2.4 Unclip side airbag wire harness from the bracket on the front seat suspension. (The bracket is installed behind the control unit for memory seat adjustment).

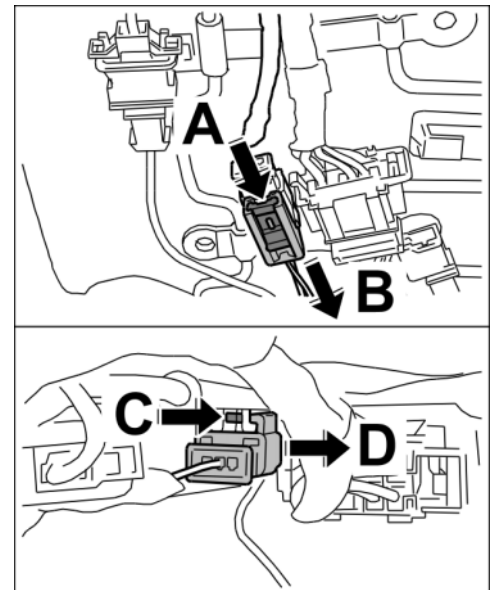

Figure 2

- 2.5 Release connector of ground strap from side airbag (⇒ *Figure 3-Item 1-*) and pull out of the socket.
  - 2.6 Release the rear connector bracket on the seat suspension and pull off socket for the ground strap (⇒ *Figure 3-Arrow A-*).
- 3 **Replace previous plug connection with a cable connection.**

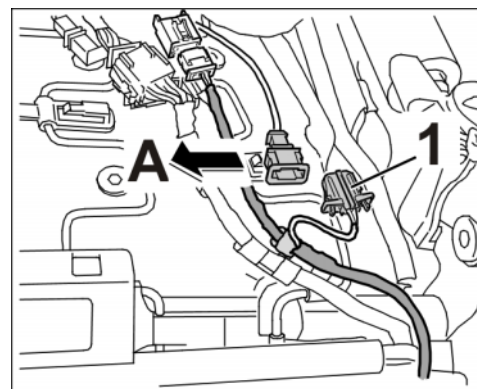

Figure 3

- 3.1 Position both lines of the wire harness on the control unit side flush on the connector and cut through them **individually** (⇒ *Figure 4*).
- 3.2 Position the two lines coming from the side airbag flush on the socket and cut through them **individually**.
- 3.3 Unwrap chafing prevention tape to a length of approx. 70 mm on the side airbag wire harness (clearance to slide on the shrink-fit hoses).
- 3.4 Slide a shrink-fit hose onto the **blue** line of the side airbag wire harness.

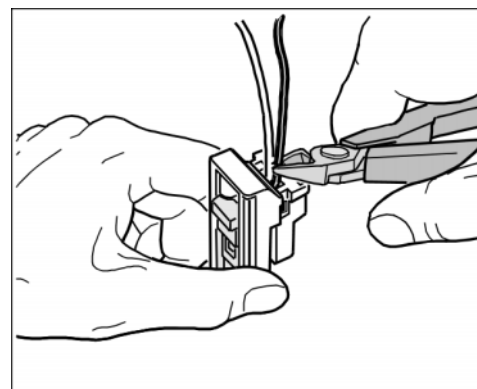

Figure 4

- 3.4.1 Strip the blue lines of the side airbag and the wire harness on the control unit side to a length of approx. 8 mm.
- 3.4.2 Crimp both blue lines with a cable connection.
- 3.5 Work on **black** line of the side airbag or control unit wire harness in the same way (= fit shrink-fit hose, strip lines by 8 mm, crimp with cable connection).

- 3.6 Position the shrink-fit hoses over the cable connections and then shrink the hoses with a hot-air gun (⇒ *Figure 5*).

#### 4 Complete the modified wire harness.

- 4.1 Wrap the unwound chafing prevention tape on the modified wire harness around and over the cable connection position.

Complete the modified wire harness with cloth adhesive tape or commercially available insulating tape.

- 4.2 Clip the socket of the ground strap (⇒ *Figure 6 -Item 1-*) into the connector bracket of the rear seat suspension and connect to the connector for the side airbag ground strap (⇒ *Figure 6 -Item 2-*).

- 4.3 Clip in the modified wire harness on the connector bracket (= position of previous side airbag plug connection) and secure to the seat suspension with a tie-wrap.

- 4.4 Engage the right tensioning strap for the backrest cover (⇒ *Figure 6 -Arrow A-*).

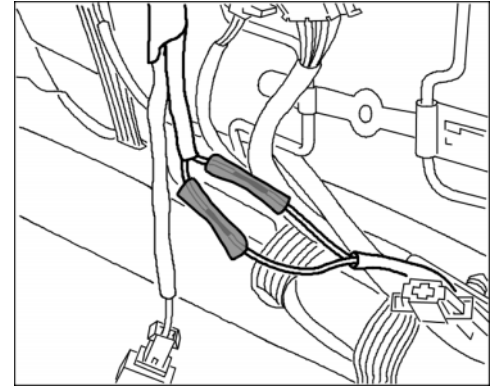

Figure 5

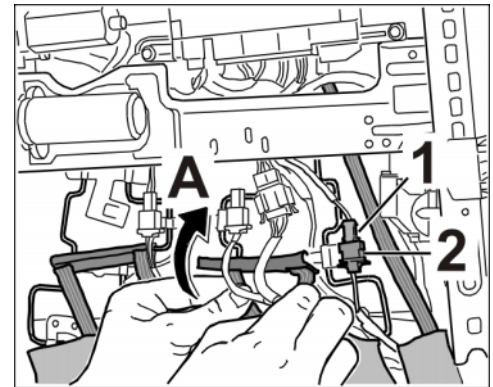

Figure 6

#### 5 Modify plug connection on passenger's seat.

- 5.1 Carry out the work listed from Step 2 to Step 4.4 on the passenger's seat.

#### 6 Concluding work.

- 6.1 Install front seats.  
6.2 Erase fault memory in airbag control unit using the PST2 or PIWIS Tester.

Working Time: 69 63 42 00 Replacing plug connection of front side airbag on both seats with **230 TU** a crimp connector.

This includes: Removing and installing front seats.

References: ⇒ *Workshop Manual '270619 Removing and installing battery'*  
⇒ *Workshop Manual '69 Safety regulations for vehicles with airbag and belt tensioner'*  
⇒ *Workshop Manual '690101 Airbag diagnosis'*  
⇒ *Workshop Manual '720119 Removing and installing front seat'*

⇒ *Workshop Manual '90 Work instructions after disconnecting the battery'*

⇒ *Technical Information '696300 Airbag warning light activated: Fault code 1217 and/or 1218 in airbag control unit fault memory'(No. 9/04).*

Workshop Equipment Manual:

( Group 2.4/No. 155-1: Repair kit for wire harnesses, Cartool Co.

**Important Notice:** Technical Bulletins issued by Porsche Cars North America, Inc. are intended only for use by professional automotive technicians who have attended Porsche service training courses. They are written to inform those technicians of conditions that may occur on some Porsche vehicles, or to provide information that could assist in the proper servicing of a vehicle. Porsche special tools may be necessary in order to perform certain operations identified in these bulletins. Use of tools and procedures other than those Porsche recommends in these bulletins may be detrimental to the safe operation of your vehicle, and may endanger the people working on it. Properly trained Porsche technicians have the equipment, tools, safety instructions, and know-how to do the job properly and safely. Part numbers listed in these bulletins are for reference only. The work procedures updated electronically in the Porsche PIWIS diagnostic and testing device take precedence and, in the event of a discrepancy, the work procedures in the PIWIS Tester are the ones that must be followed.

© 2022 Porsche Cars North America, Inc.