



# Volvo Particulate Matter (PM) Sensor Troubleshooting Guide - US14+OBD16 And Newer Emissions



## Overview

V2 PM SENSOR



The Particulate Matter (PM) Sensor is a smart sensor that is located after the SCR Catalyst to measure the amc exhaust. The smart sensor communicates on the DL7 (J1939-7) data link and is used to report the condition of Filter (DPF).

The primary failure mode the PM Sensor is internal failure, which will generate a fault code.

## Diagnosis and Repair

### Review Before Beginning



The PM Sensor is a smart sensor that reads solid matter (particulates) instead of a gas like most other smart sensors. Extreme care must be given when handling these sensors.

- Handle with extreme care. Sensors contain a ceramic element that is fragile.
- Never use a lubricant on the sensor threads or tip.
- Proper Orientation of the sensor is required.

• Replacement instructions can be found under the Service tab in [Impact](#).

• **DO NOT CUT THE HARNESS** when initially attempting to remove the sensor. A 22 mm Oxygen Sensor socket will keep the harness intact.

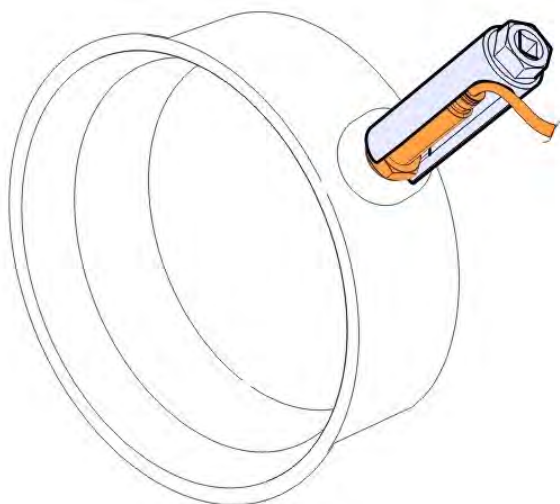

• If damage to the threads occurs when removing the sensor, replace the bung as outlined in [Technical Service Bulletins, One Box, Replacement. PM, NOx and Temperature Sensor Fittings](#), found under the service tab in [Impact](#).

• If multiple PM sensor failures have been experienced, check for water damage as outlined in [Technical Service Bulletin 284-069 Exhaust Particulate Sensor, Repair \(2017 Vehicles\)](#), or [284-068 Exhaust Particulate Sensor, Repair](#) found in [Impact](#).

1. Navigate to the Service tab.

2. In the Info Type box, make sure Technical Service Bulletins is selected.

3. In the Additional search values box select Keyword

4. Enter [258-039](#) into the text entry box, press the Search button.

5. A link for the article will be shown in the results. Click on the title, then choose one of the options from the window that

**REPLACE the sensor if any codes in red below are active and/or confirmed on the Readout.**

<b>Fault Code</b>	<b>Fault Description</b>
P103100	Particulate Matter Sensor Clogged Tip
P103200	Particulate Matter Sensor Removed from Exhaust
P24AE13	Particulate Matter Sensor
P24AF00	Particulate Matter Sensor Circuit Range/Performance
P24B000	Particulate Matter Sensor Circuit Low
P24B100	Particulate Matter Sensor Circuit High
P24B313	Particulate Matter Sensor Heater Control Circuit Open
P24B492	Particulate Matter Sensor Heater Control Circuit Range/Performance
P24B500	Particulate Matter Sensor Heater Control Circuit Low
P24B700	Particulate Matter Sensor Heater Resistance
P24D100	Particulate Matter Sensor Regeneration Incomplete
P24DA00	Particulate Matter Sensor Exhaust Sample Error Bank 1
P24FC00	Particulate Matter Sensor Heater Control Circuit Driver Current/Temperature Too High
P2AB047	Particulate Matter Sensor Processor

**DO NOT REPLACE the sensor for any of the codes in green below.** The sensor is not the failed component. A diagnostic test must be performed to find the root cause.

<b>Fault Code</b>	<b>Fault Description</b>	<b>Probable Source</b>
P103400	Particulate Matter Sensor System Voltage Too High	Power supply
P24D000	Particulate Matter Sensor Supply Voltage Circuit Low	Power supply
U02A300	Lost Communication With PM Sensor	Wiring harness and connectors
P200200	Diesel Particulate Filter Efficiency Below Threshold (Bank 1)	<ul style="list-style-type: none"> <li>• Diesel Particulate Filter (DPF) clogged</li> <li>• Engine Control Module (EMS)</li> </ul>

## Rules For Replacement

- Warranty will only cover replacement of the PM Sensor if one of the codes in Red listed above is present. If the sensor is suspected to have failed with no codes present, an eService case is required for further evaluation.
- Standard Diagnostic Time for a PM Sensor is 0.4 hrs.

<a href="#">u02a300</a>	<a href="#">p200200</a>	<a href="#">p103100</a>	<a href="#">p103200</a>	<a href="#">p24ae13</a>	<a href="#">p24af00</a>
<a href="#">p24b000</a>	<a href="#">p24b100</a>	<a href="#">p24b313</a>	<a href="#">p24b492</a>	<a href="#">p24da00</a>	<a href="#">p24fc00</a>
<a href="#">p2ab047</a>	<a href="#">p24b500</a>	<a href="#">p24b700</a>	<a href="#">p24d100</a>	<a href="#">unlocking uptime</a>	
<a href="#">volvo</a>	<a href="#">p103400</a>	<a href="#">p24d000</a>			

### Related links and attachments

[TSB 258-039](#)

[TSB 284-069](#)

[TSB 284-068](#)



### Feedback

[Give feedback](#) to help improve the cont



# SCR Fittings, One Box, Replacement

PM, NOx and Temperature Sensor Fittings

V-258-039

August (2021)

## Valid for

Volvo VN, VHD, VAH trucks equipped with a one-box SCR aftertreatment system.

## Case description

"Some trucks may require replacement of SCR fittings such as NOx sensor, temperature sensor, PM (Particulate Matter) sensor. Follow the instruction outlined in this document to replace the sensor boss or bosses in the one box SCR."

## Standard Repair Procedure

Labor Code	
Muffler, replace. (Combined DOC-DPF-SCR)	2589-03-02-43
OR	
Muffler, replace. (Combined DOC-DPF-SCR) (decontented)	2586-03-02-10

Note: Replacement of aftertreatment muffler is not necessary if the sensor boss threads are damaged during service.

Volvo Trucks released all ATD sensor bosses.

Note: This repair requires TIG or MIG welding and should be performed by a certified technician. Stainless Steel welding wire/rod (ER308) recommended with appropriate shielding gas (Argon).

## Required Parts

Part Description	New part number	Quantity
Boss temperature sensor	23144461	1
Boss NOx sensor	23501651	1
Boss PM sensor	23501654	1

## Required Tools

Carbide Tip Hole Saw Size	Sensor Boss
1-3/16 (30 mm)	PM Sensor Boss
1-1/4 (32 mm)	NOx Sensor Boss M20
1-1/16 (27 mm)	Temperature Sensor Boss M14

## Procedure



### Warning

Risk of burn injuries.  
Allow the engine to cool before start work on the Aftermarket system.



### Caution

Service Information Advisory.  
If you are not properly trained and certified in this procedure, ask your supervisor for training before you perform it.  
You must read and understand the precautions and guidelines in Service Information, Function Group 2, "General Safety Practices, Engine" before performing this procedure.

Note: This repair procedure only applies to the sensor bosses located on the SCR outlet pipe.

Note: The 1-Box SCR should be removed from the vehicle when the following procedure is performed.

Note: The illustration shown in this procedure to remove or install the bosses is general, replace only the damaged boss/bosses. Do not replace the undamaged boss/bosses.

1. Remove the damaged boss welding.

Note: If the PM sensor boss is damaged as shown in the illustration mark the position of sensor boss notch before removing the boss welding. The notch of PM sensor boss is always set in the 3'o clock position.

Note: Use the sensor boss to pilot the hole saw.

Note: When removing the sensor boss weld, check the depth frequently to prevent the damaged sensor boss from falling inside the aftertreatment muffler. Also ensure that the notch mark is not removed.

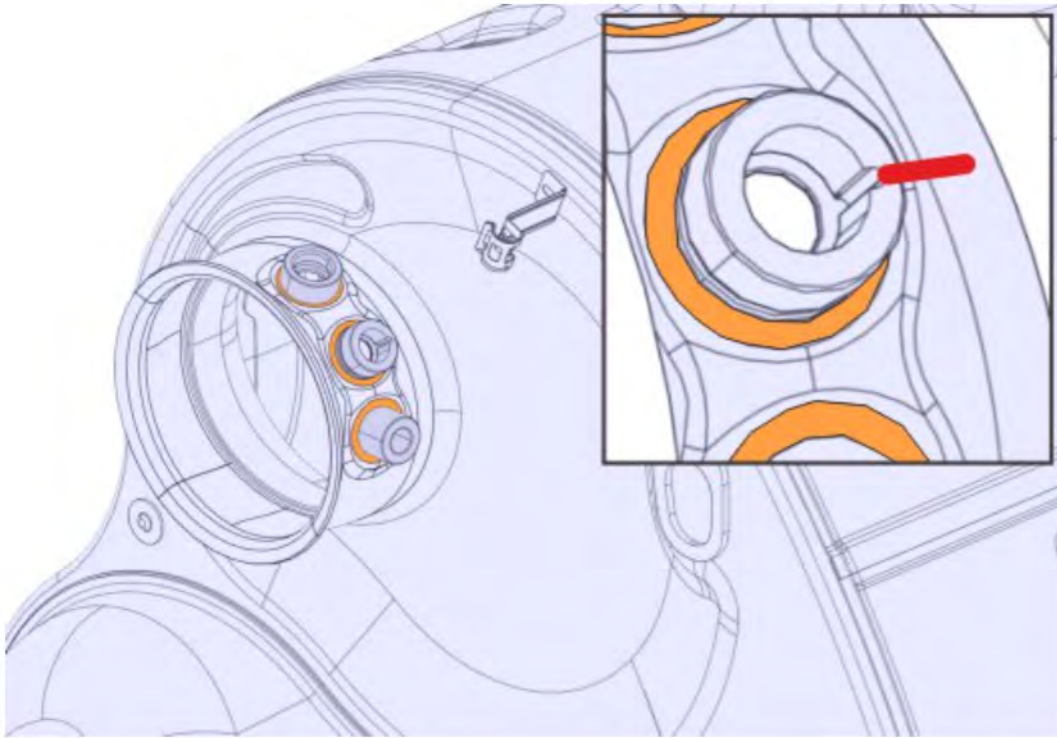

**2. Remove the damaged boss/bosses (Temperature/NOx/PM sensors).**

Copyright to this documentation belongs to the Volvo Group. No reproduction, copying, change, amendment or other similar disposal is entitled without prior written consent by the Volvo Group

The information contained herein is current at the time of its original distribution, but is subject to change. The reader is advised that printed copies are uncontrolled.

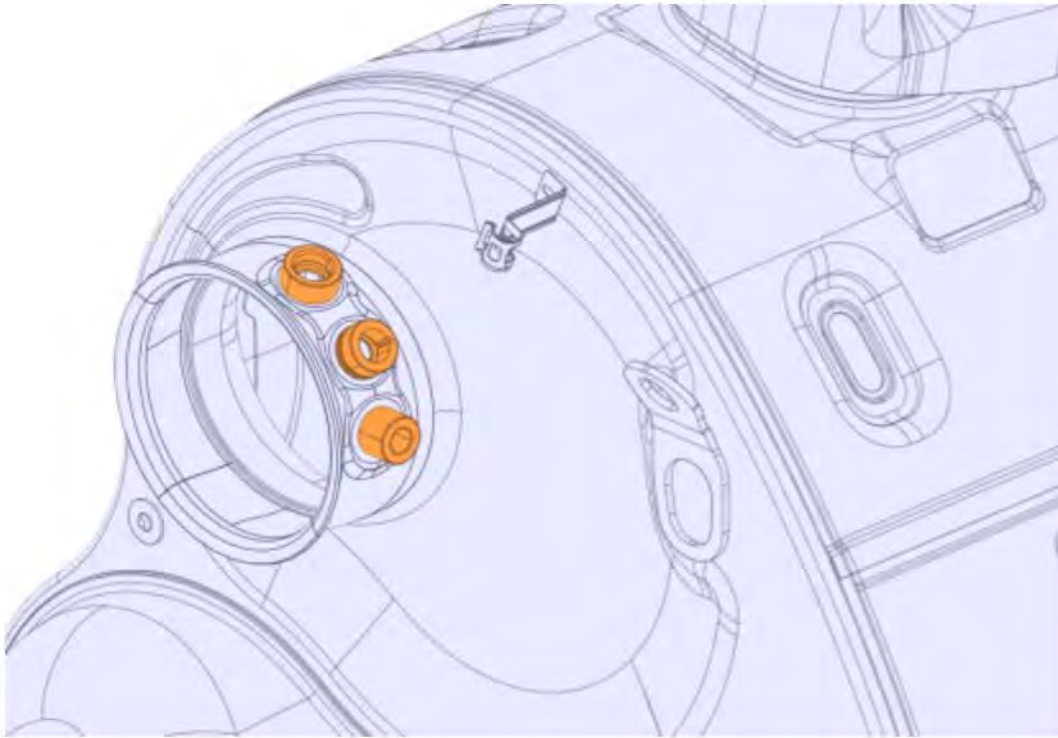

3. Clean off all metal shavings from around the sensor boss hole. Prevent metal chips from entering the Aftertreatment muffler.
4. Verify that the new sensor boss fits the sensor before welding in place.

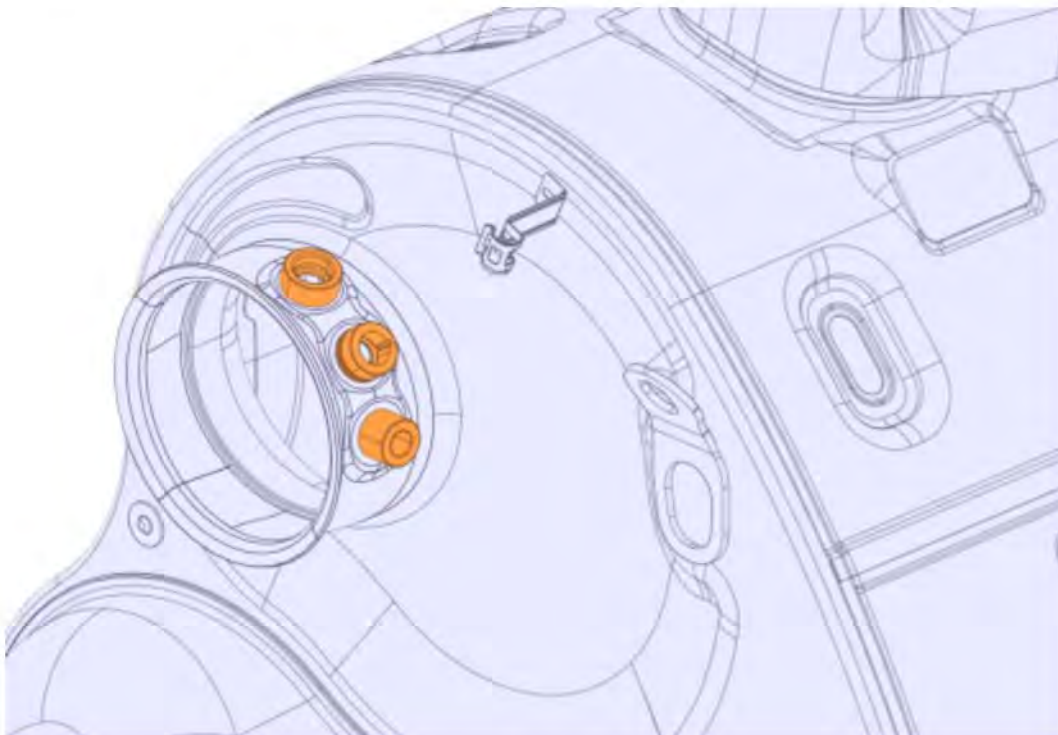

5. Install the new sensor boss and perform the welding.

Note: When replacing the PM sensor boss, position the notch of new boss as marked. The notch of PM sensor boss is always set in the 3'o clock position.

6. Tack weld the sensor boss, complete the weld around the boss.



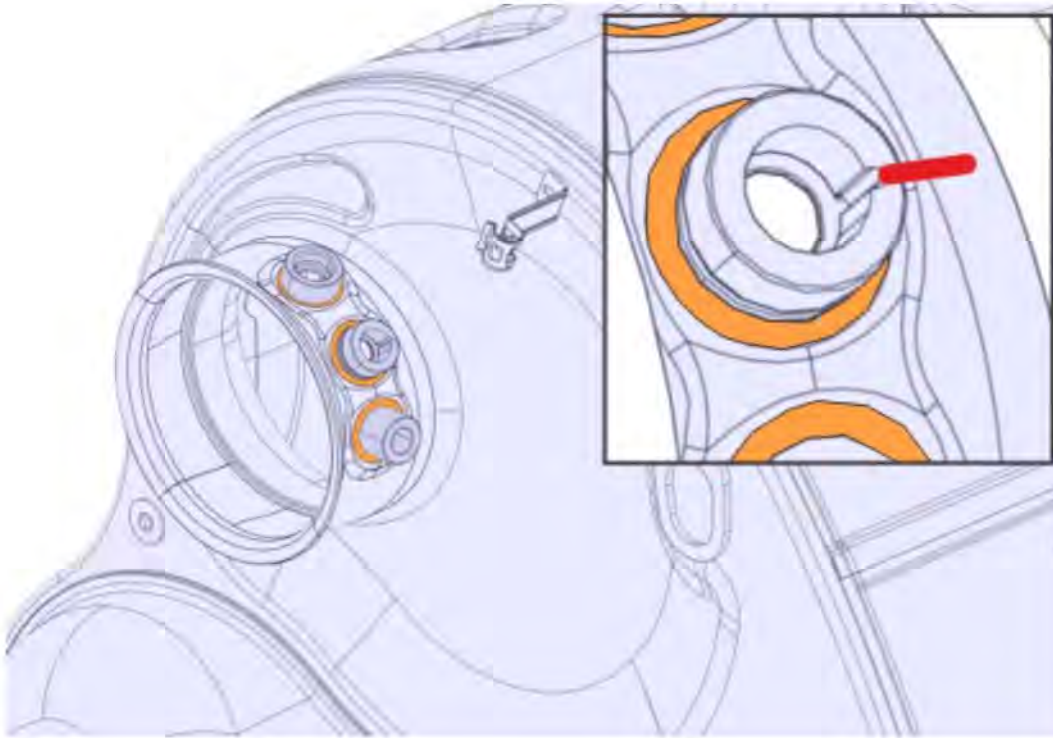

## Warranty information

### Reimbursement

This repair may be eligible for reimbursement if a product failure was experienced within time and mileage limits of the applicable warranty coverage. Reimbursement is obtained via the normal claim handling process.	UCHP Reimbursement
Claim type (used only when uploading from the dealer Bus. Sys.)	01
Labor Code	
SCR Fittings, one box, replace (one boss)	2589-03-09-04 (0.3 hrs)

## Issued by

### Technical Service

Volvo Trucks reserves the right to make any changes in design or to make additions to or upon its products without incurring any obligations to install the same on vehicles previously built.

# Exhaust Particulate Sensor, Repair

V-284-068

(October 2020)

## Valid for

Volvo with a 2 Box exhaust after-treatment system (EATS) and built between January 1st, 2016 and February 3rd, 2020.

## Case description

Some trucks may experience a Particulate Matter (PM) Sensor fault that can result in the MIL lamp illuminating. These faults may be P24DA, "PM Sensor Exhaust Sample Error," or P24D1, "PM Sensor Regen Incomplete." These faults may be caused by contamination of the PM sensor. In order to reduce the likelihood of sensor contamination, new exhaust pipe parts are being made available that contain an internal water management feature along with an integrated drain that will prevent contamination of the sensor. If either of these two faults occur, follow the instructions outlined in this bulletin to clean the exhaust pipes and install a new exhaust pipe with the new contamination prevention measures.

## Required Parts – All Years

Inspect and replace the v-band clamp as needed

A new gasket will be needed when disconnecting the SCR exit.

Note: No gasket needed for vertical SCR.

Part Description	Part Number
SCR Gasket	21095726
V-band Clamp	21021850
Particulate Matter Sensor	22303391

Note: Customer adaptations can change required parts. Check for adaptations before ordering parts. (For example, under-slung exhaust)

## Table of Contents

Model	Cab Type	Exhaust Configuration	Repair Number
VNL	Day Cab	Single Outlet Right Side Outboard	1
VNM / VHD	Day Cab	Single Outlet Right Side Inboard	2
VNM / VHD	430 / 630	Single Outlet Right Side Inboard	3

Copyright to this documentation belongs to the Volvo Group. No reproduction, copying, change, amendment or other similar disposal is entitled without prior written consent by the Volvo Group

The information contained herein is current at the time of its original distribution, but is subject to change. The reader is advised that printed copies are uncontrolled.

VNL	430 / 670 / 780 Sleeper	Single Outlet Right Side Inboard	4
VNL	430 / 670 / 780 Sleeper	Dual Outlet Inboard	5
VHD / VNM	All	SCR RH Horizontal Forward Mount	6
VNL 11 / 13	All	SCR Horizontal	6
All	All	Exhaust Stack Right Side	7

## Repair Procedure

Determine which Flex Pipe and Clamp the truck currently has installed on it. If the truck you are repairing has the Flex Pipe and Clamp shown in scenario 1, you will need to order the improved Flex Pipe (P/N 21142254) and Clamp (P/N 25172497). If the truck you are repairing has the Flex Pipe and Clamp shown in scenario 2, this truck already has the improved parts and ordering a new Flex Pipe and Clamp is NOT required.

	<p>Scenario 1</p> <p>This style Flex Pipe and Clamp will no longer work with the upper adjacent connecting pipe. The below parts in scenario 2 are required to perform this FSB.</p> <p>Follow the repair below that is applicable for your configuration.</p>
--	--



#### Scenario 2

This style Flex Pipe and Clamp only needs the upper adjacent pipe replaced. Reuse the existing Flex Pipe and Clamp, or order as needed.

Flex Pipe –  
21142254

Clamp –  
25172497



Follow the repair below that is applicable for your configuration.

## Under Cab SCR Exhausts

### Repair 1

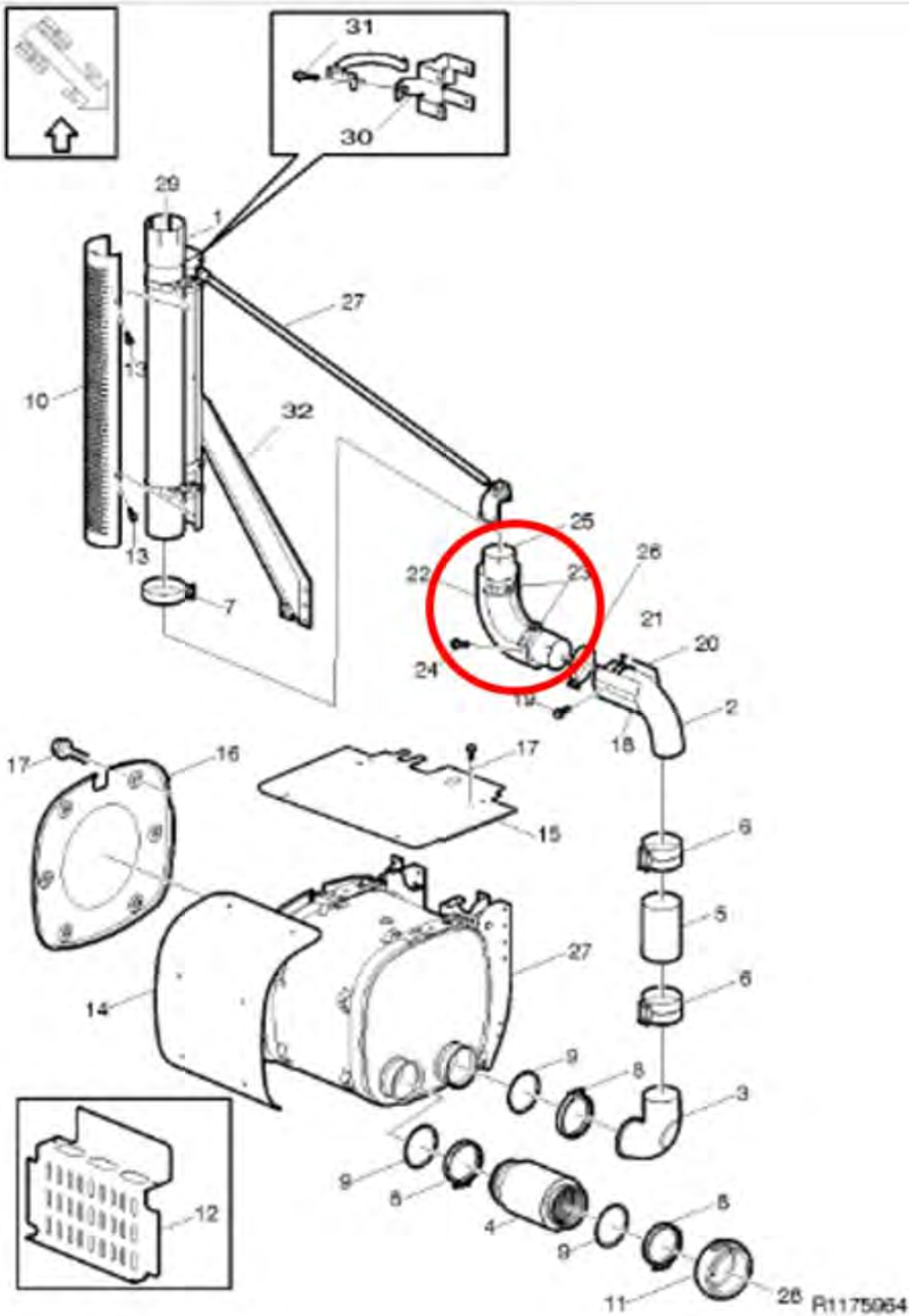

Model	Cab Type	Exhaust Configuration	Pipe 1
VNL	Day Cab	Single Outlet Right Side Outboard	(Not Bright) 23154798 (Bright) 23154799

Copyright to this documentation belongs to the Volvo Group. No reproduction, copying, change, amendment or other similar disposal is entitled without prior written consent by the Volvo Group

The information contained herein is current at the time of its original distribution, but is subject to change. The reader is advised that printed copies are uncontrolled.

Note: If the original flex pipe has previously been replaced, you will need a new elbow in addition to the new flex pipe.

Model	Cab Type		Elbow
VNL	Day Cab	Single Outlet Right Side Outboard	21274193

Repair 2

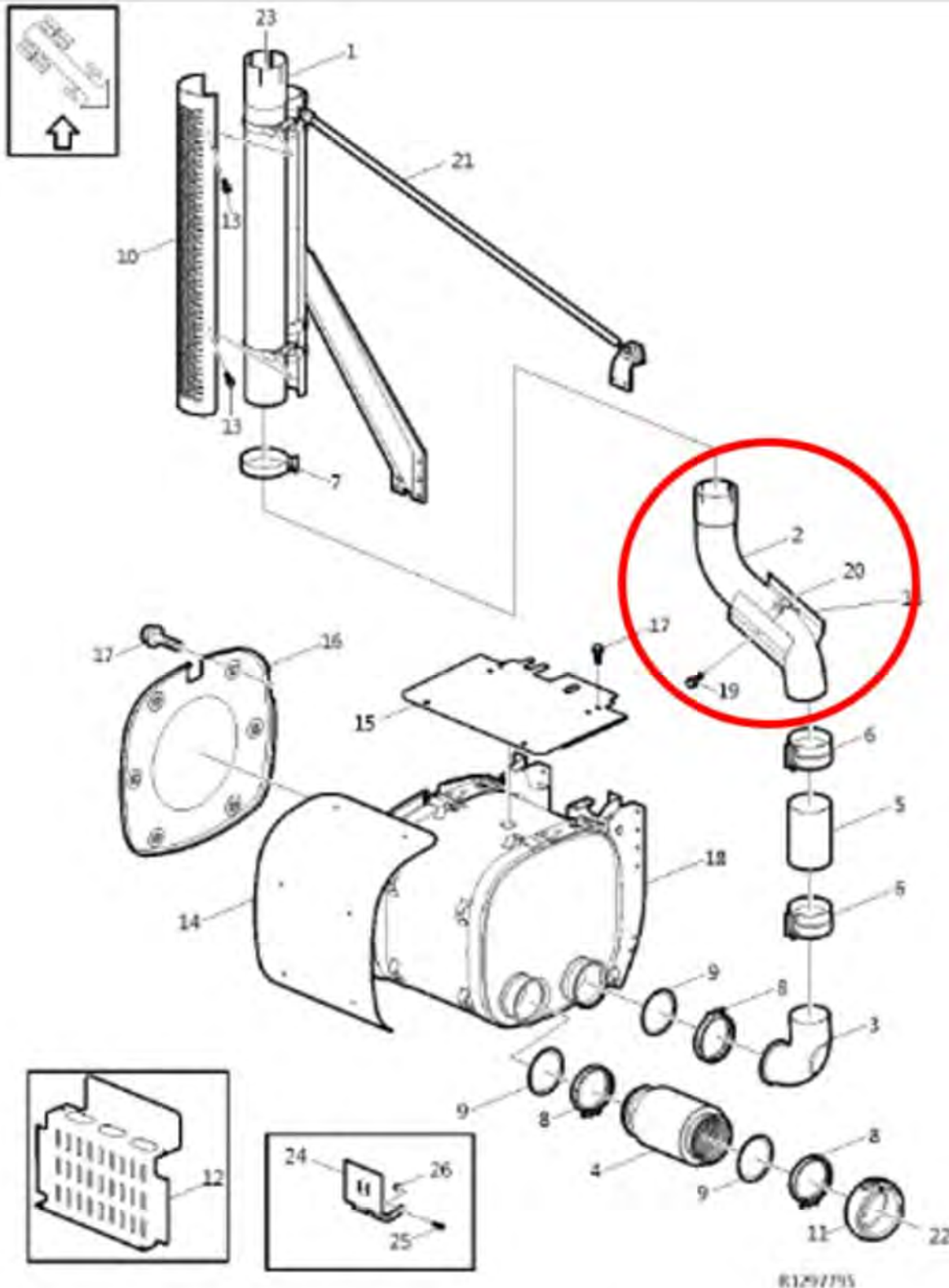

Copyright to this documentation belongs to the Volvo Group. No reproduction, copying, change, amendment or other similar disposal is entitled without prior written consent by the Volvo Group

The information contained herein is current at the time of its original distribution, but is subject to change. The reader is advised that printed copies are uncontrolled.

Model	Cab Type	Exhaust Configuration	Pipe 1
VNM/VHD	Day Cab	Single Outlet Right Side Inboard	23630037

Repair 3

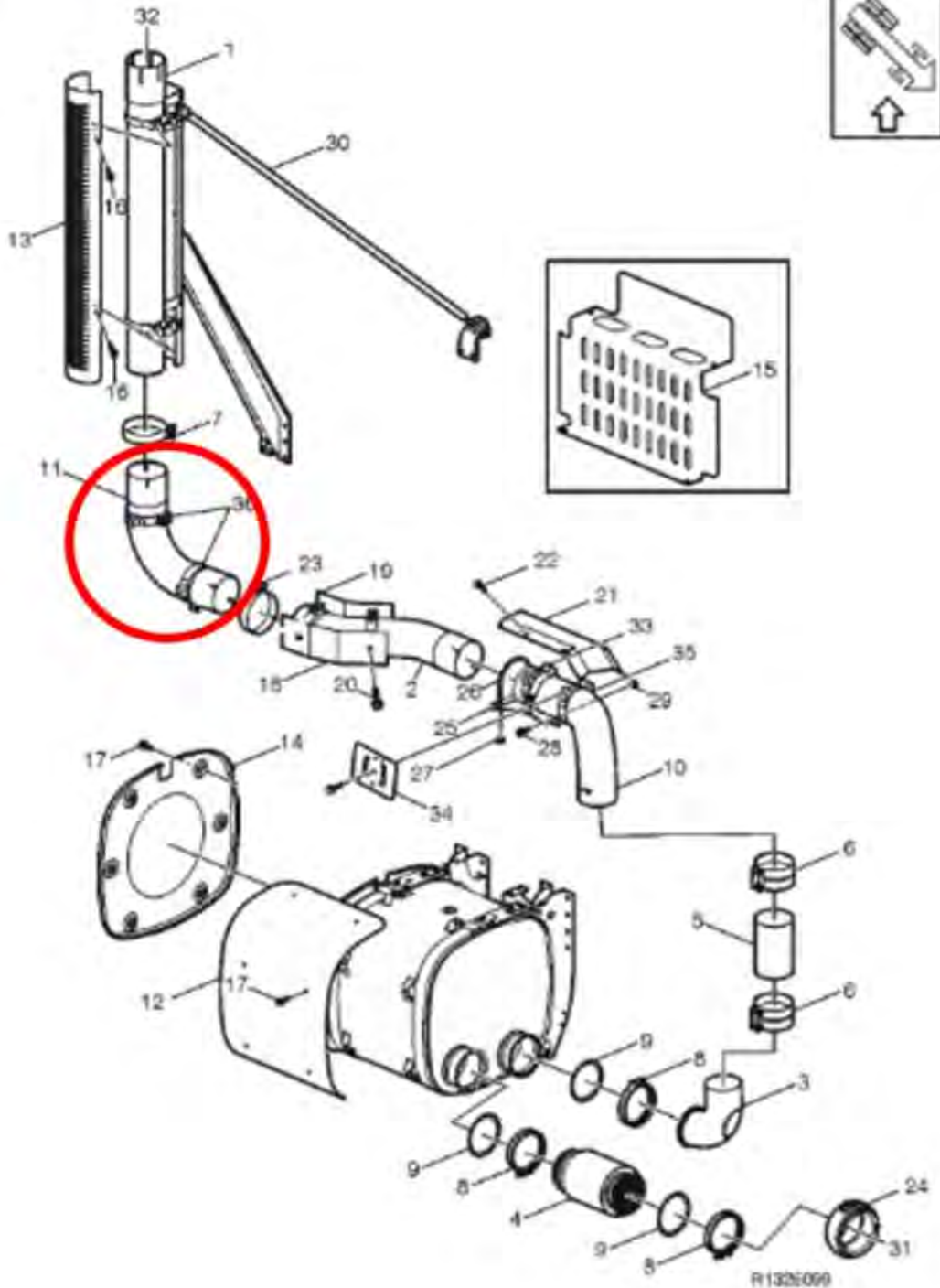

Model	Cab Type	Exhaust Configuration	Pipe 1
VNL/VHD	430/630 Sleeper	Single Outlet Right Side Inboard	(Not Bright) 23154798

Copyright to this documentation belongs to the Volvo Group. No reproduction, copying, change, amendment or other similar disposal is entitled without prior written consent by the Volvo Group

The information contained herein is current at the time of its original distribution, but is subject to change. The reader is advised that printed copies are uncontrolled.



			(Bright) 23154799
--	--	--	----------------------

Note: If the original flex pipe has previously been replaced, you will need a new elbow in addition to the new flex pipe.

Model	Cab Type	Exhaust Configuration	Elbow
VNL/VHD	430/630 Sleeper	Single Outlet Right Side Inboard	21687278

#### Repair 4

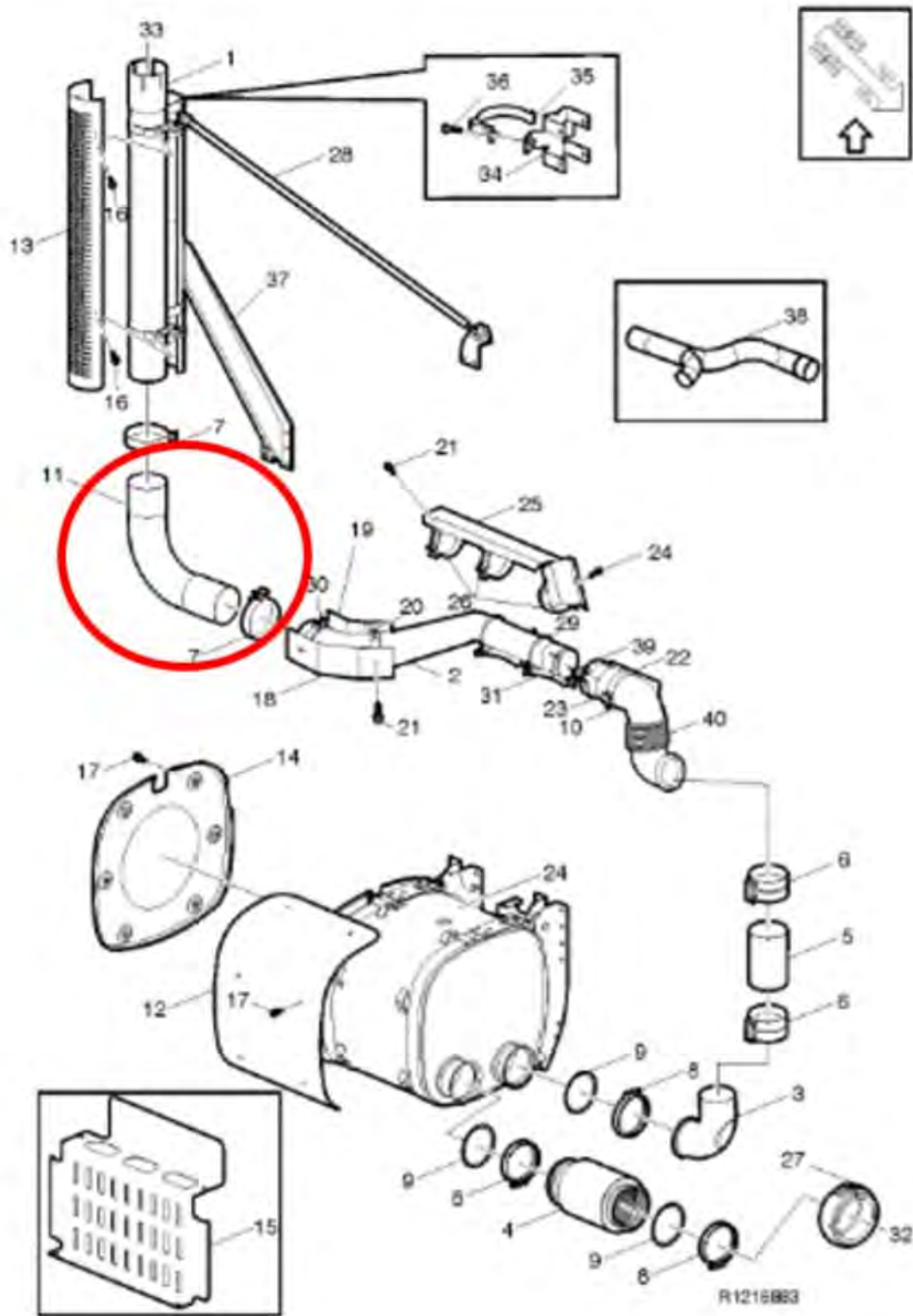

Model	Cab Type	Exhaust Configuration	Pipe 1
VNL	430/670/780 Sleeper	Single Outlet Right Side Inboard	(Not Bright) 23154798 (Bright) 23154799

Note: If the original flex pipe has previously been replaced, you will need a new elbow in addition to the new flex pipe

Copyright to this documentation belongs to the Volvo Group. No reproduction, copying, change, amendment or other similar disposal is entitled without prior written consent by the Volvo Group

The information contained herein is current at the time of its original distribution, but is subject to change. The reader is advised that printed copies are uncontrolled.

Model	Cab Type	Exhaust Configuration	Elbow
VNL	430 Sleeper	Single Outlet Right Side Inboard	21625282

Model	Cab Type	Exhaust Configuration	Elbow
VNL	670/780 Sleeper	Single Outlet Right Side Inboard	21625281

## Repair 5

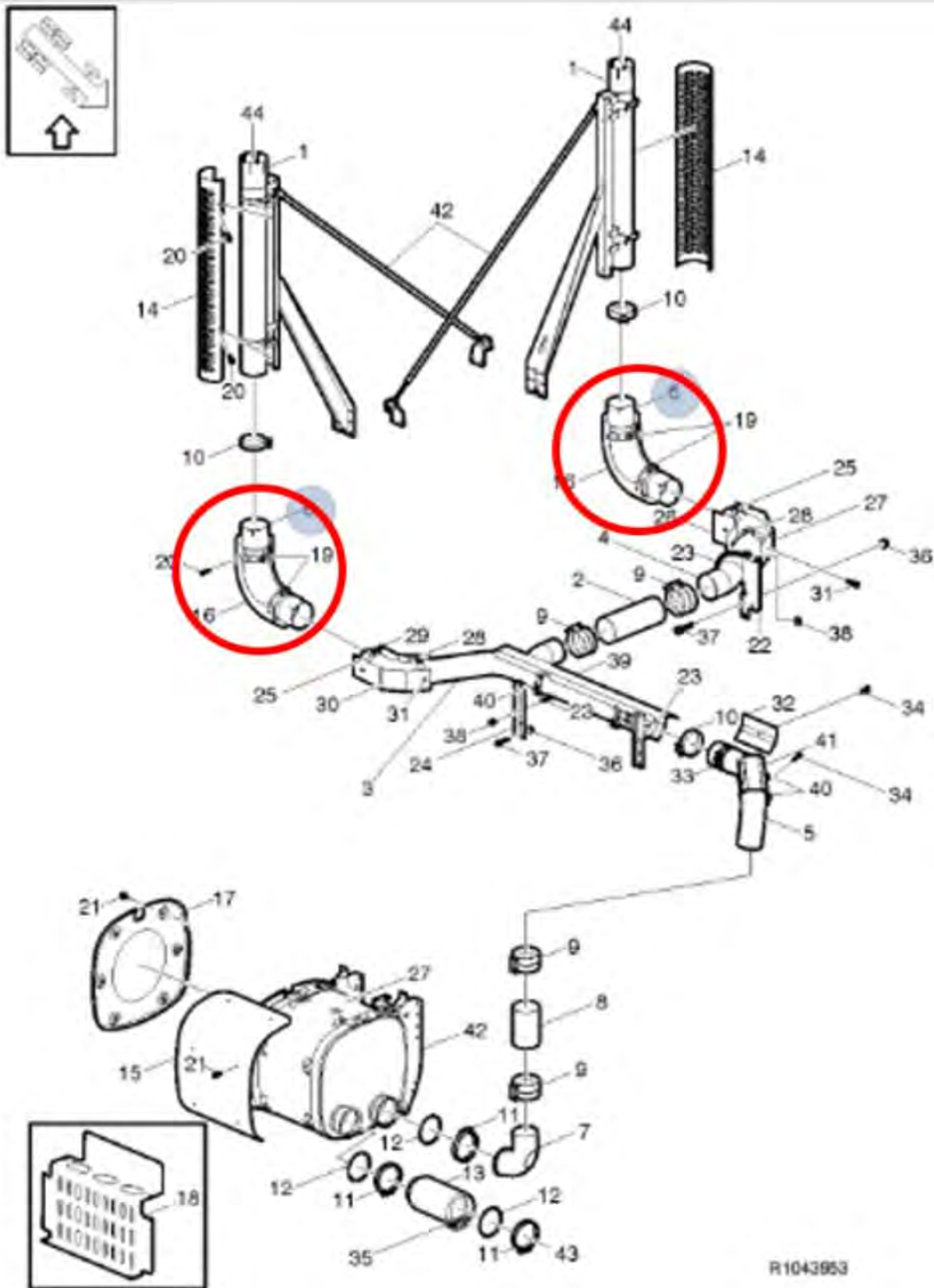

R1043953

Model	Cab Type	Exhaust Configuration	Pipe 1
VNL	430/670/780 Sleeper	Single Outlet Right Side Inboard	(Not Bright) 23154798 (Bright) 23154799

Copyright to this documentation belongs to the Volvo Group. No reproduction, copying, change, amendment or other similar disposal is entitled without prior written consent by the Volvo Group

The information contained herein is current at the time of its original distribution, but is subject to change. The reader is advised that printed copies are uncontrolled.

Note: If the original flex pipe has previously been replaced, you will need a new elbow in addition to the new flex pipe

Model	Cab Type	Exhaust Configuration	Elbow
VNL	430 Sleeper	Single Outlet Right Side Inboard	21625282

Model	Cab Type	Exhaust Configuration	Elbow
VNL	670/780 Sleeper	Single Outlet Right Side Inboard	21625281

## Repair 6

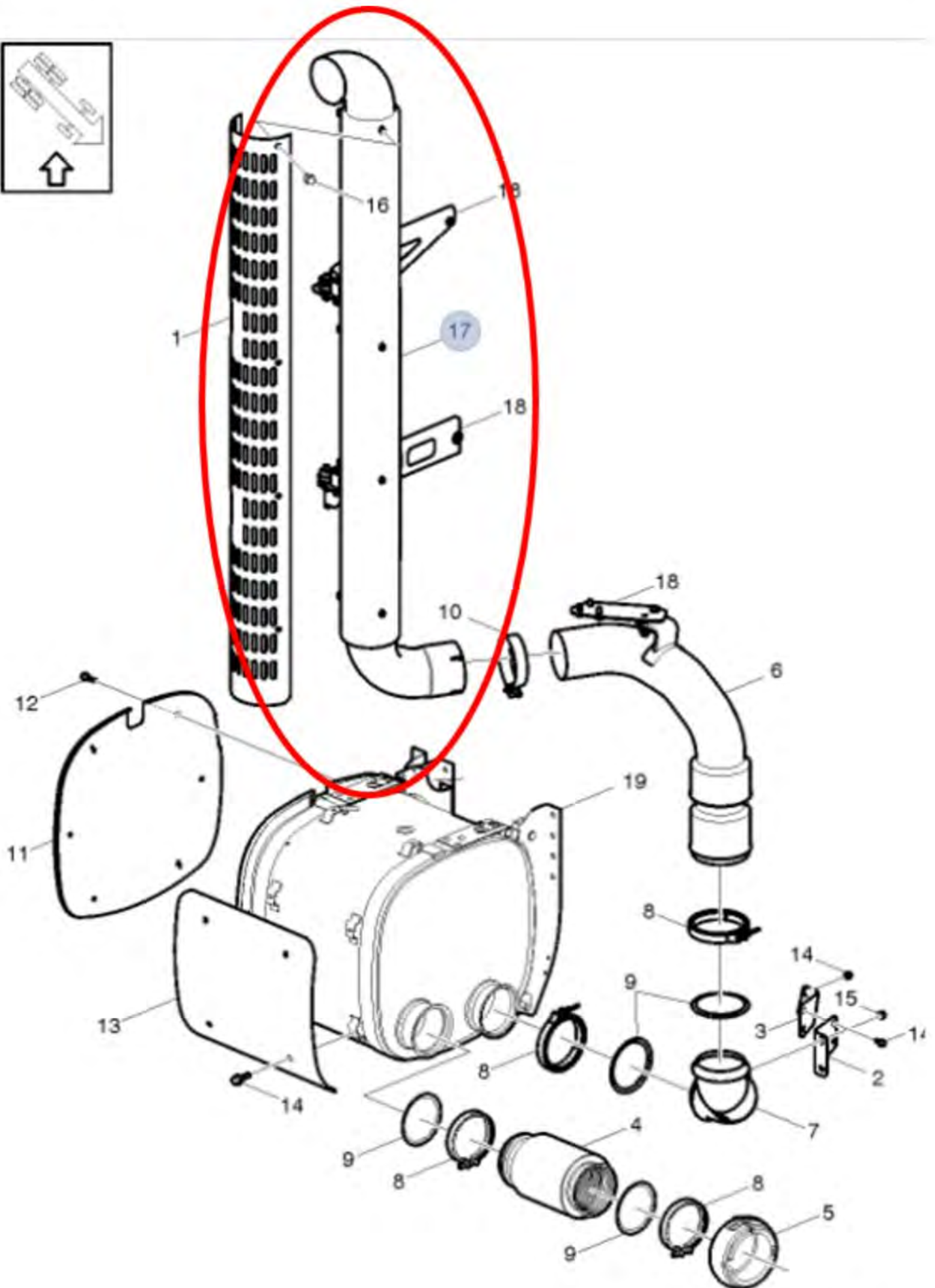

R1058691

Copyright to this documentation belongs to the Volvo Group. No reproduction, copying, change, amendment or other similar disposal is entitled without prior written consent by the Volvo Group

The information contained herein is current at the time of its original distribution, but is subject to change. The reader is advised that printed copies are uncontrolled.

Model	Cab Type	Exhaust Configuration	Pipe 1	Clamp (Qty will vary)
VHD/VNM	Cab Mounted	SCR RH Horizontal Forward Mount	23154823	20961913
VHD/VNM	Cab Mounted	SCR Horizontal	23154825	20961913
VNL 11/13	Cab Mounted	SCR Horizontal	23154827	20961913

Repair 7

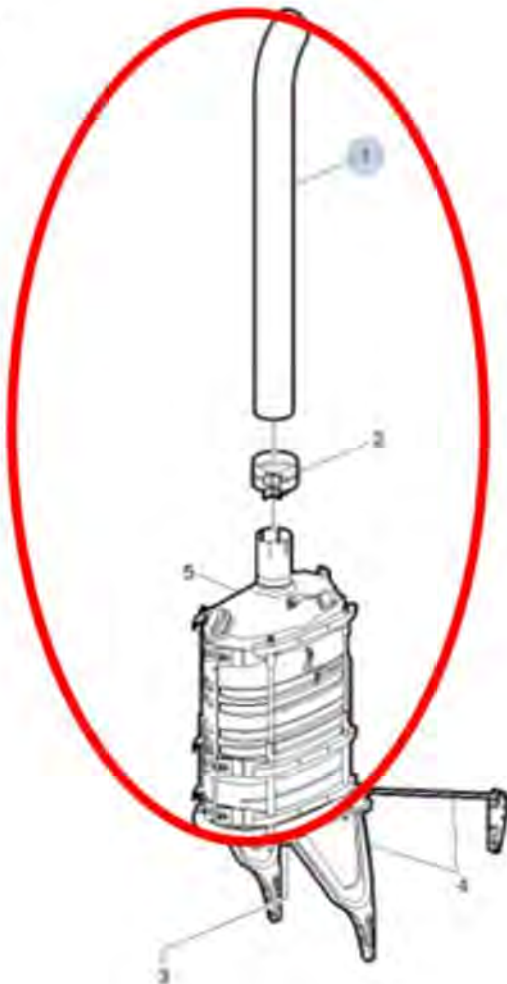

R164222

Model	Cab Type	Exhaust Configuration	Pipe 1	Pipe Insert	Clamp (Qty will vary)

Copyright to this documentation belongs to the Volvo Group. No reproduction, copying, change, amendment or other similar disposal is entitled without prior written consent by the Volvo Group

The information contained herein is current at the time of its original distribution, but is subject to change. The reader is advised that printed copies are uncontrolled.

					vary)
All	16L	12.5 ft Exhaust Stack Right Side	23208705	23296273	23189982
All	11L / 13L	11 ft 8 in Exhaust Stack Right Side	(Not Bright) 23208698 (Bright) 23208699	23176623	23189982
All	11L / 13L	12 ft 6 in Exhaust Stack Right Side	(Not Bright) 23208700 (Bright) 23208701	23176623	23189982
All	11L / 13L	13 ft 5 in Exhaust Stack Right Side	(Not Bright) 23208702 (Bright) 23208703	23176623	23189982

## Instructions

1. Decommission the vehicle. Install wheel chocks and disconnect the battery.

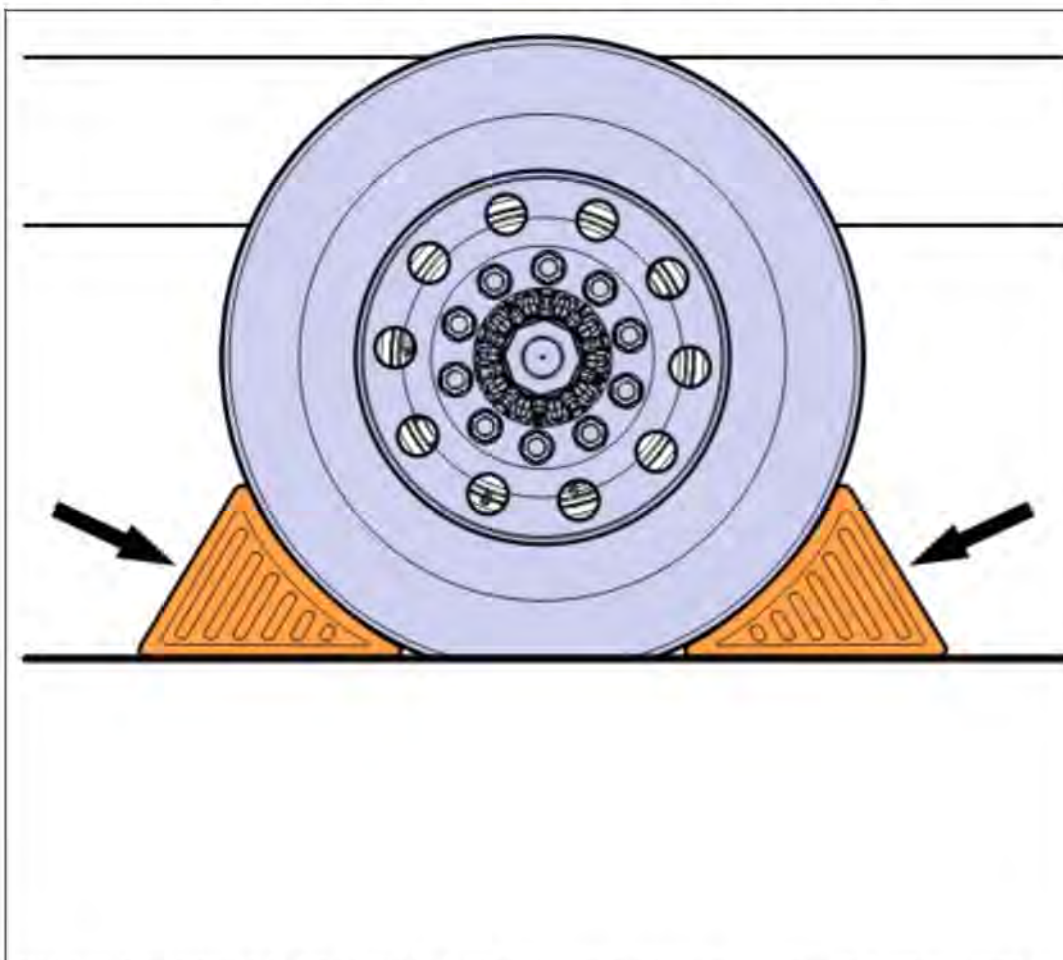





2. Remove the PM sensor and module.
3. Remove all exhaust pipes up to the SCR outlet pipe.
4. Pressure wash the inside of each pipe that will be reused.
5. Reassemble the exhaust system using the new parts referenced in the table above.
6. Mark the SCR outlet pipe 1.5" from the end also mark the new pipe (not flex) 1.5" from its inlet.
7. Slip the flex pipe as far over the SCR outlet pipe as possible.
8. Install the new exhaust pipe.
9. Using a new clamp assemble the new exhaust pipe to the new flex pipe using the 1.5" mark to get the correct amount of overlap.
10. Slide the assembly into place using the 1.5" mark on the SCR outlet as a reference point and to ensure the correct amount of overlap, once in both pipes are in place use clamps to secure.

Note: Correct installation is achieved when the flex pipe is in a "relaxed" state, there should be no compression or expansion visible on opposing sides of the pipe after installed.

11. Install the new PM sensor and module.

Note: Do not use any lubricant of any kind on the PM sensor threads.

Note: Align the tab on the sensor with the slot.

12. Torque the sensor to 35 +/- 5 Nm (26 +/- 4 Ft lb)

13. Install the sensor module.
14. Torque the nuts to  
M6: 10 +/- 5 Nm (88 +/- 3 in lb)  
M8: 24 +/- 4 Nm (17.1 +/- 3 ft lb)
15. Install the wire ties and clamps.

Note: Use high temperature cable ties.

16. Connect the battery.

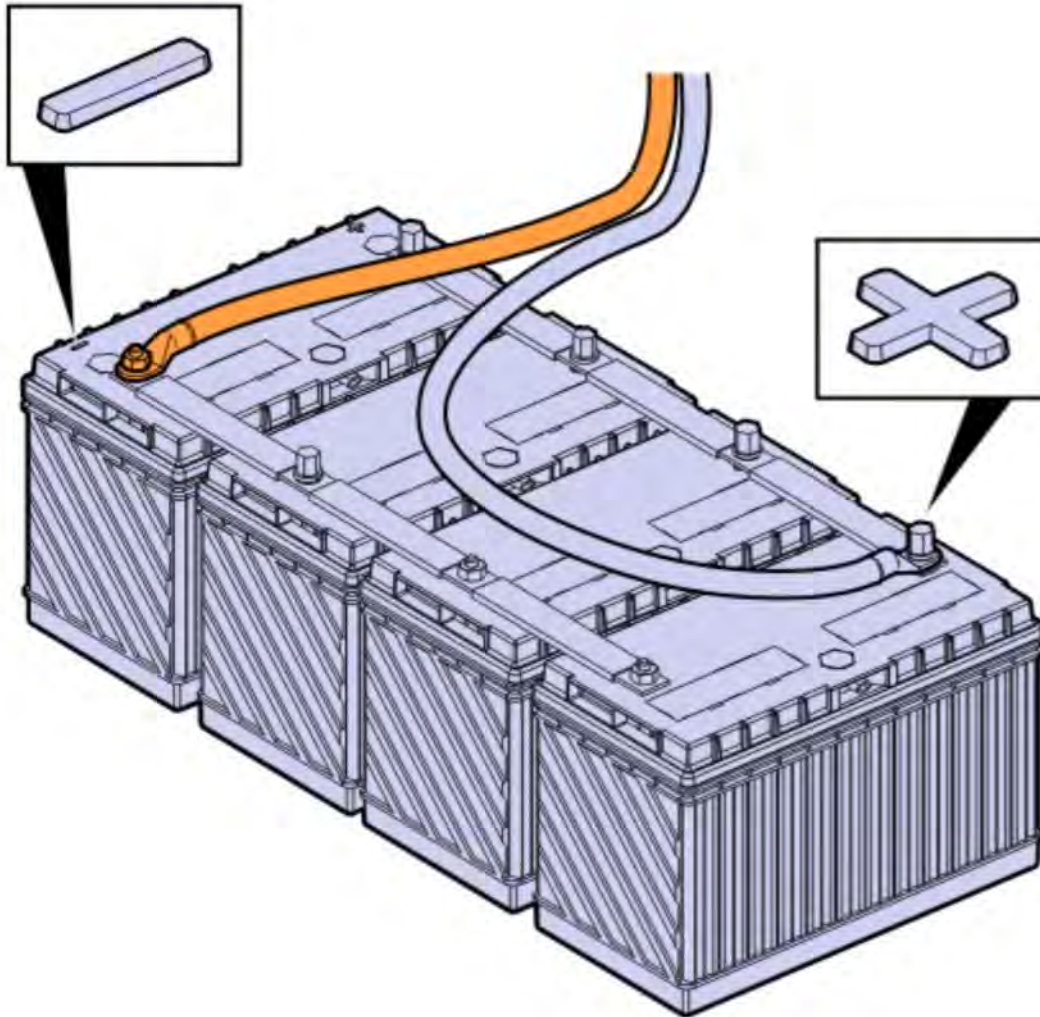

17. Clear any DTC codes.
18. Remove the wheel chocks.

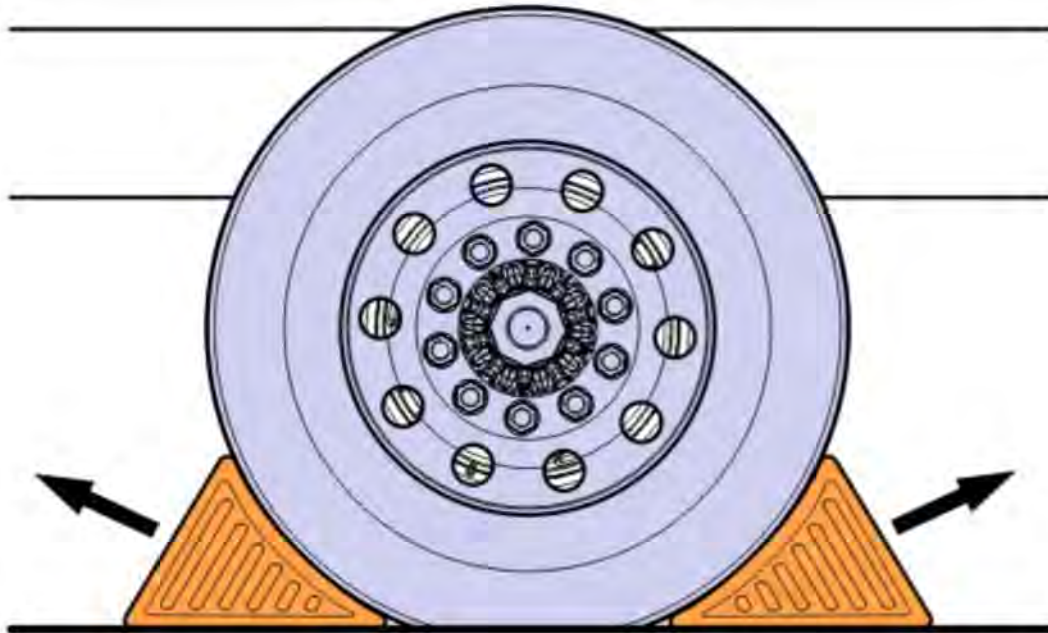

## Warranty information

### Reimbursement

This repair may be eligible for reimbursement if a product failure was experienced within time and mileage limits of the applicable Warranty coverage. Reimbursement is obtained via the normal claim handling process.	UCHP Reimbursement
Claim Type (used only when uploading from the Dealer Bus. Sys.)	W
Labor Code	
Primary Labor Code (Exhaust Particulate Sensor, Repair)	2846-16-09-01 See table for times.
Causal Part	22946032

## Labor Times Reference – 2016 Vehicles

Model	Cab Type	Exhaust Configuration	Pipe 1
VNL	Day Cab	Single Outlet Right Side Outboard	2.1

Copyright to this documentation belongs to the Volvo Group. No reproduction, copying, change, amendment or other similar disposal is entitled without prior written consent by the Volvo Group

The information contained herein is current at the time of its original distribution, but is subject to change. The reader is advised that printed copies are uncontrolled.

VNM VHD	Day Cab	Single Outlet Right Side Inboard	2.1
VNM VHD	430/630 Sleeper	Single Outlet Right Side Inboard	3.0
VNL	430 Sleeper	Single Outlet Right Side Inboard Dual Outlet	3.5
VNL	670/780 Sleeper	Single Outlet Right Side Inboard Dual Outlet	3.5
VHD/VNM	Cab Mounted	SCR RH Horizontal Forward Mount	1.7
VHD/VNM	Cab Mounted	SCR Horizontal	1.7
VNL 11/13	Cab Mounted	SCR Horizontal	1.7

### Back of Cab SCR Exhausts

Model	Engine Size	Exhaust Configuration	Pipe
All	16L	12.5 ft Exhaust Stack Right Side	0.8
All	11L / 13L	11 ft 8 in Exhaust Stack Right Side	0.8
All	11L / 13L	12 ft 6 in Exhaust Stack Right Side	0.8
All	11L / 13L	13 ft 5 in Exhaust Stack Right Side	0.8

## Issued by

Technical Service

# Exhaust Particulate Sensor, Repair

V-284-069

(November 2021)

## Valid for

Volvo trucks with a 1-box exhaust after-treatment system (EATS) and built between January 1, 2017 and February 1, 2020

## Case description

Some trucks may experience a Particulate Matter (PM) Sensor fault that can result in the MIL lamp illuminating. These faults may be P24DA, "PM Sensor Exhaust Sample Error," or P24D1, "PM Sensor Regen Incomplete." These faults may be caused by contamination of the PM sensor. In order to reduce the likelihood of sensor contamination, new exhaust pipe parts are being made available that contain an internal water management feature along with an integrated drain that will prevent contamination of the sensor. If either of these two faults occur, follow the instructions outlined in this bulletin to clean the exhaust pipes and install a new exhaust pipe with the new contamination prevention measures.

## Required Parts – All Years

Inspect and replace the v-band clamp as needed

A new gasket will be needed when disconnecting the SCR exit.

Part Description	Part Number
SCR Gasket	21095726
V-band Clamp	21021850
Particulate Matter Sensor	23320447

Note: Customer adaptations can change required parts. Check for adaptations before ordering parts. (For example, under-slung exhaust)

## Repair Procedure

Determine which Flex Pipe and Clamp the truck currently has installed on it. If the truck you are repairing has the Flex Pipe and Clamp shown in scenario 1, you will need to order the improved Flex Pipe (P/N 21142254) and Clamp (P/N 25172497). If the truck you are repairing has the Flex Pipe and Clamp shown in scenario 2 or 3, this truck already has the improved parts and ordering a new Flex Pipe and Clamp is NOT required.

	<p>Scenario 1</p> <p>This style Flex Pipe and Clamp will no longer</p>
--	--



work with the upper adjacent connecting pipe. The below parts in scenario 2 are required to perform this FSB.

Follow the repair below that is applicable for your configuration.

Scenario 2

This style Flex Pipe and Clamp only needs the upper adjacent pipe replaced. Reuse the existing Flex Pipe and Clamp, or order as needed.

Flex Pipe –  
21142254

Clamp –  
25172497

Follow the repair below that is applicable for your configuration.



**Scenario 3**

This style Flex Pipe and Clamp only needs the upper adjacent pipe replaced. Reuse the existing Flex Pipe and Clamp, or order as needed.

Follow the repair below



that is applicable for your configuration.

### Table of Contents

Model	Cab Type	Exhaust Configuration	Repair Number
VNL	Day Cab	Single Outlet Right Side Outboard	1
VHD Axle Fwd	Day Cab	Single Outlet Right Side Outboard	2
VNM, VHD Axle Bwd	Day Cab	Single Outlet Right Side Outboard	3
VHD Axle Bwd	Day Cab	Dual Outlet	4
VHD Axle Fwd	Day Cab	Dual Outlet	4
VNM, VHD, VNL	Sleeper Cabs	Single Outlet Right Side Outboard	5

Copyright to this documentation belongs to the Volvo Group. No reproduction, copying, change, amendment or other similar disposal is entitled without prior written consent by the Volvo Group

The information contained herein is current at the time of its original distribution, but is subject to change. The reader is advised that printed copies are uncontrolled.



		Dual Outlet	
VNM, VHD, VNL	Sleeper Cabs	Single Outlet Right Side Outboard Dual Outlet	6

Repair 1

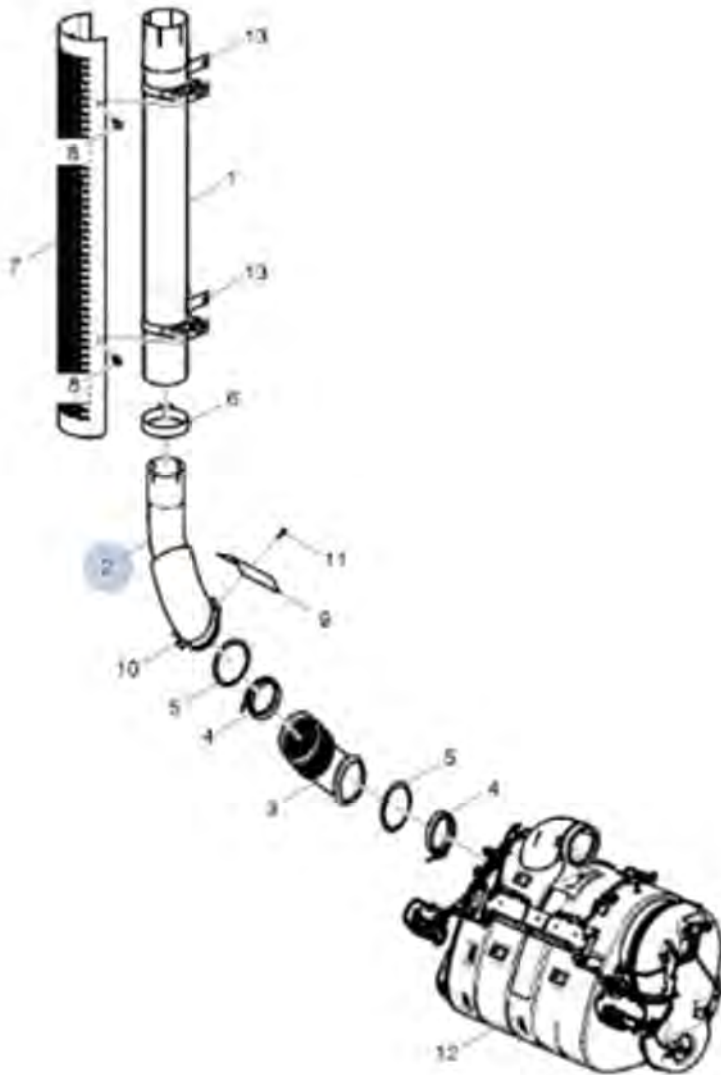

Model	Cab Type	Exhaust Configuration	Pipe 1 (Stack with welded flex)	Pipe 2 (SCR Elbow)	Clamp
VNL	Day Cab	Single Outlet Right Side Outboard	23985907	22181981	25172497

Repair 2

Copyright to this documentation belongs to the Volvo Group. No reproduction, copying, change, amendment or other similar disposal is entitled without prior written consent by the Volvo Group

The information contained herein is current at the time of its original distribution, but is subject to change. The reader is advised that printed copies are uncontrolled.

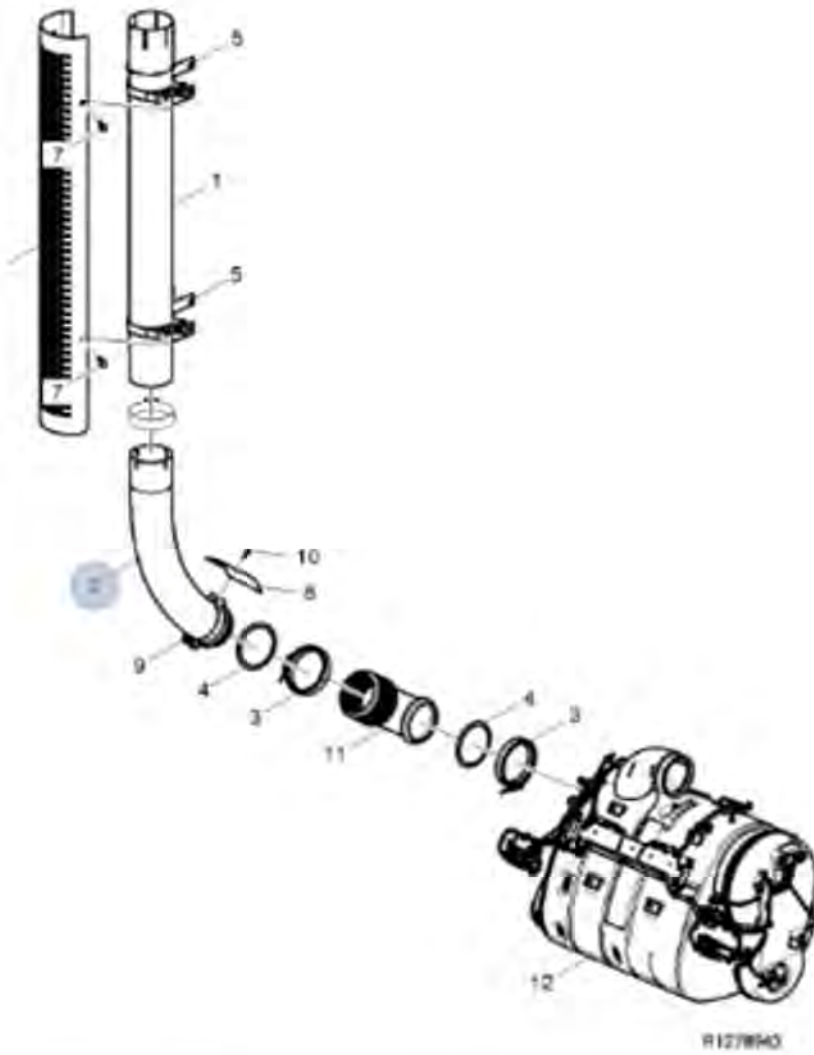

Model	Cab Type	Exhaust Configuration	Pipe 1
VHD – Axle Forward	Day Cab	Single Outlet Right Side Inboard	23155762

Repair 3

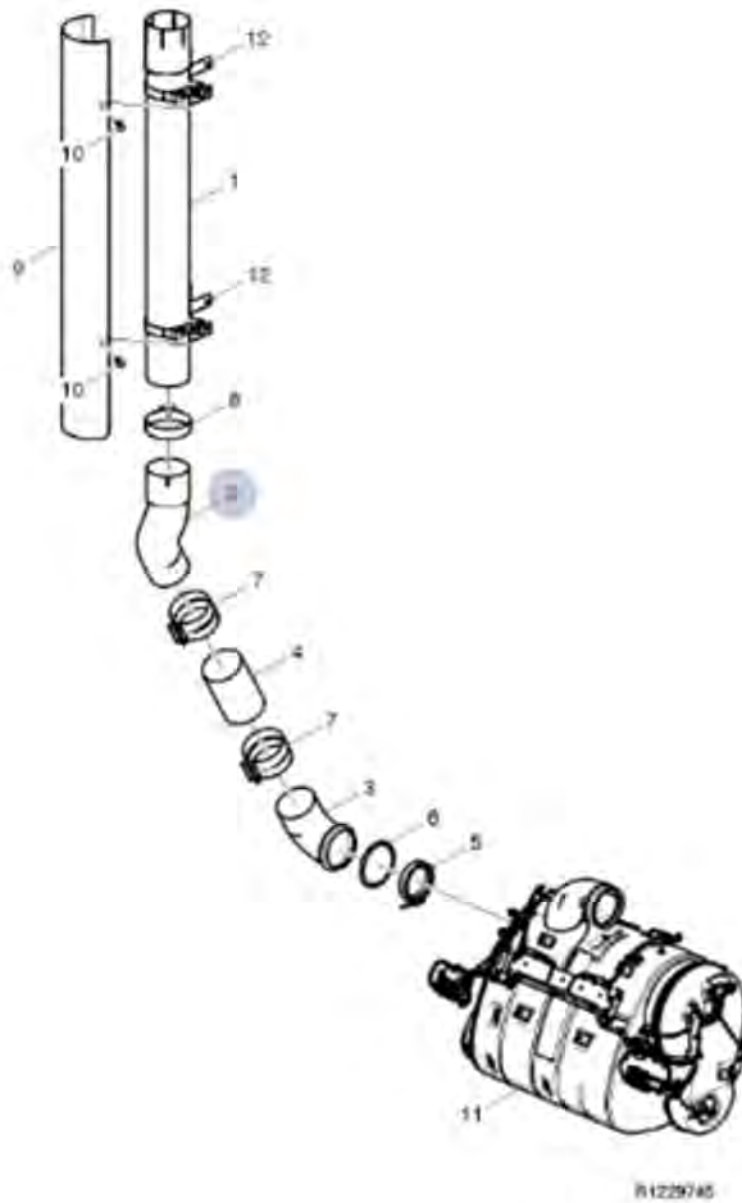

Model	Cab Type	Exhaust Configuration	Pipe 1
VNM/VHD	Day Cab	Single Outlet Right Side Inboard	23630048

Repair 4

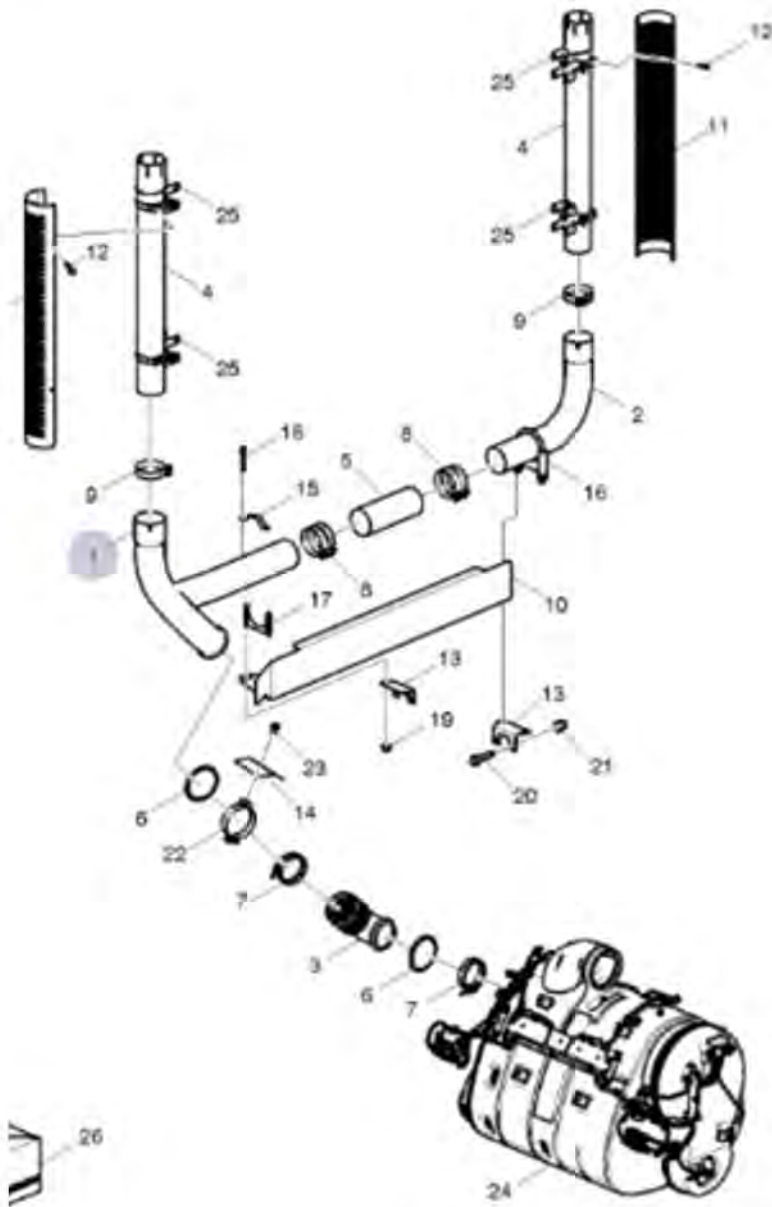

11241574

Model	Cab Type	Exhaust Configuration	Pipe 1
VHD Axle Bwd	Day Cab	Dual Outlet	23155774
VHD Axle Fd	Day Cab	Dual Outlet	23155785

### Repair 5

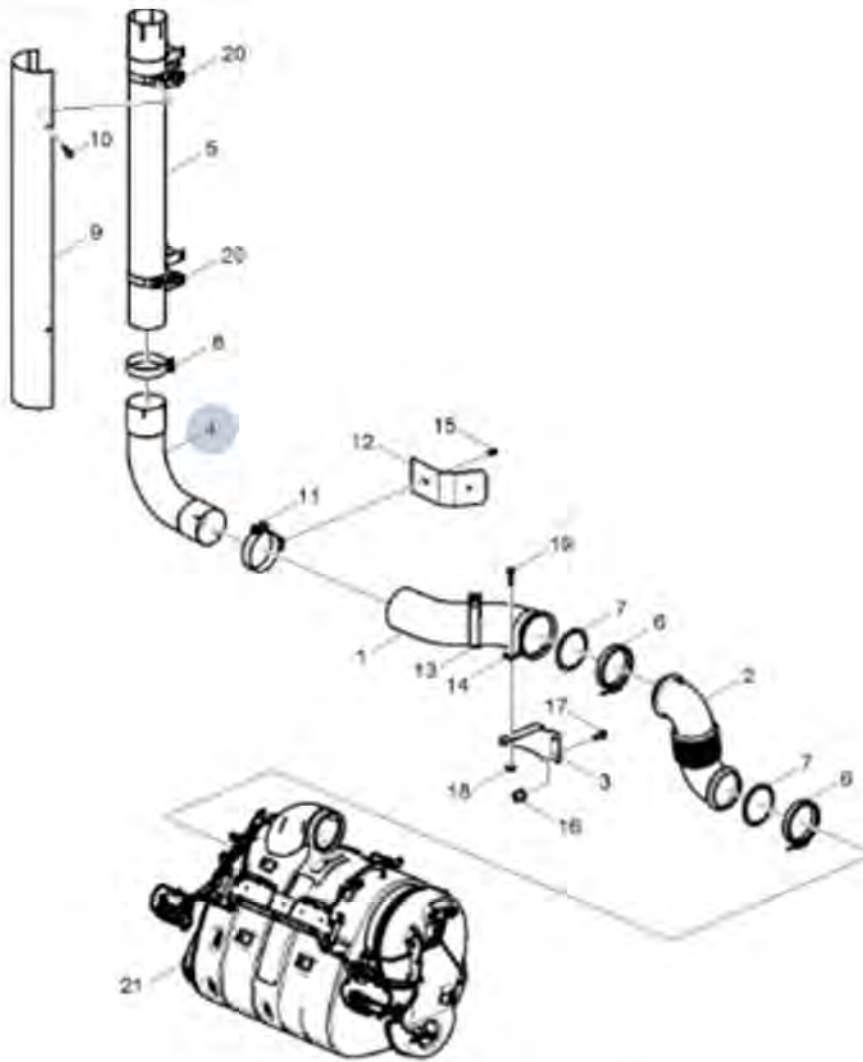

Model	Cab Type	Exhaust Configuration	Pipe 1
VNM VHD VNL	Sleeper Cabs	Single Outlet Right Side Outboard	(Not Bright) 23154798 (Bright) 23154799

### Repair 6

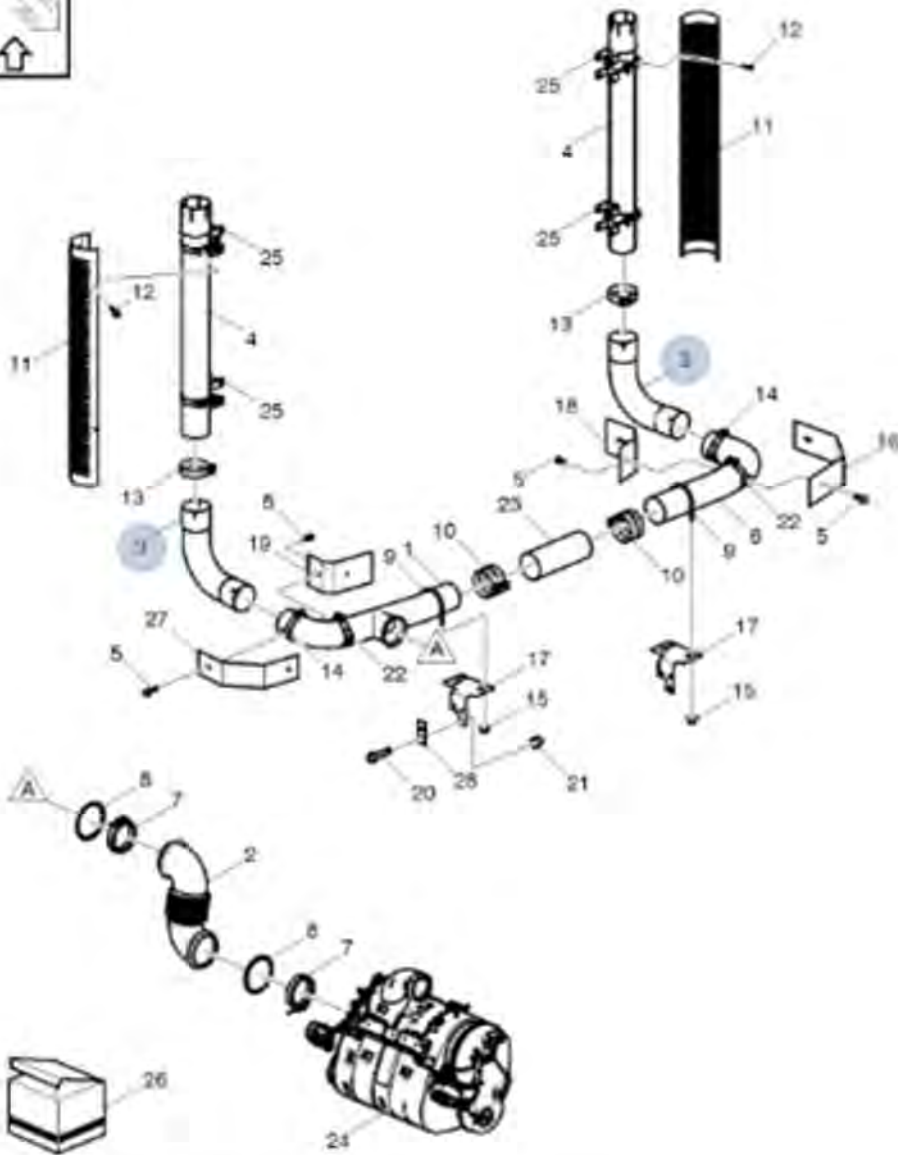

Model	Cab Type	Exhaust Configuration	Pipe 1	Note
VNM VHD VNL	Sleeper Cabs	Dual Outlet Right Side Outboard	(Not Bright) 23154798 (Bright) 23154799	Requires 2 elbows per chassis

## Instructions

1. Decommission the vehicle. Install wheel chocks and disconnect the battery.



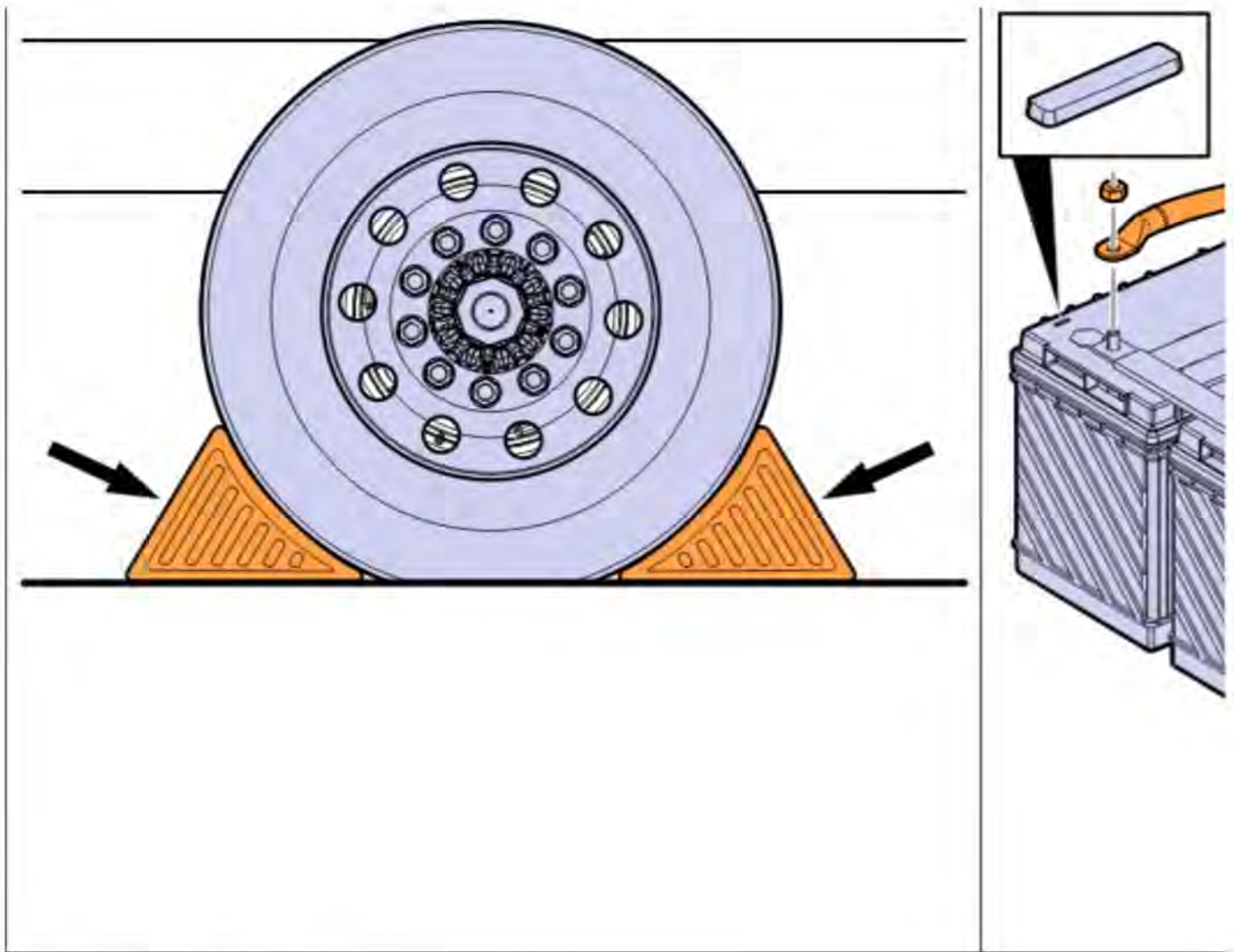

2. Remove the PM sensor and module.
3. Remove all exhaust pipes up to the SCR outlet pipe.
4. Pressure wash the inside of each pipe that will be reused.
5. Reassemble the exhaust system using the new parts referenced in the table above.
6. Mark the SCR outlet pipe 1.5" from the end also mark the new pipe (not flex) 1.5" from its inlet.
7. Slip the flex pipe as far over the SCR outlet pipe as possible.
8. Install the new exhaust pipe.
9. Using a new clamp assemble the new exhaust pipe to the new flex pipe using the 1.5" mark to get the correct amount of overlap.
10. Slide the assembly into place using the 1.5" mark on the SCR outlet as a reference point and to ensure the correct amount of overlap, once in both pipes are in place use clamps to secure.

Note: Correct installation is achieved when the flex pipe is in a "relaxed" state, there should be no compression or expansion visible on opposing sides of the pipe after installed.

11. Install the new PM sensor and module.

Note: Do not use any lubricant of any kind on the PM sensor threads.

Note: Align the tab on the sensor with the slot.

12. Torque the sensor to 35 +/- 5 Nm (26 +/- 4 Ft lb)

Copyright to this documentation belongs to the Volvo Group. No reproduction, copying, change, amendment or other similar disposal is entitled without prior written consent by the Volvo Group

The information contained herein is current at the time of its original distribution, but is subject to change. The reader is advised that printed copies are uncontrolled.

13. Install the sensor module.
14. Torque the nuts to  
M6: 10 +/- 5 Nm (88 +/- 3 in lb)  
M8: 24 +/- 4 Nm (17.1 +/- 3 ft lb)
15. Install the wire ties and clamps.

Note: Use high temperature cable ties.

16. Connect the battery.

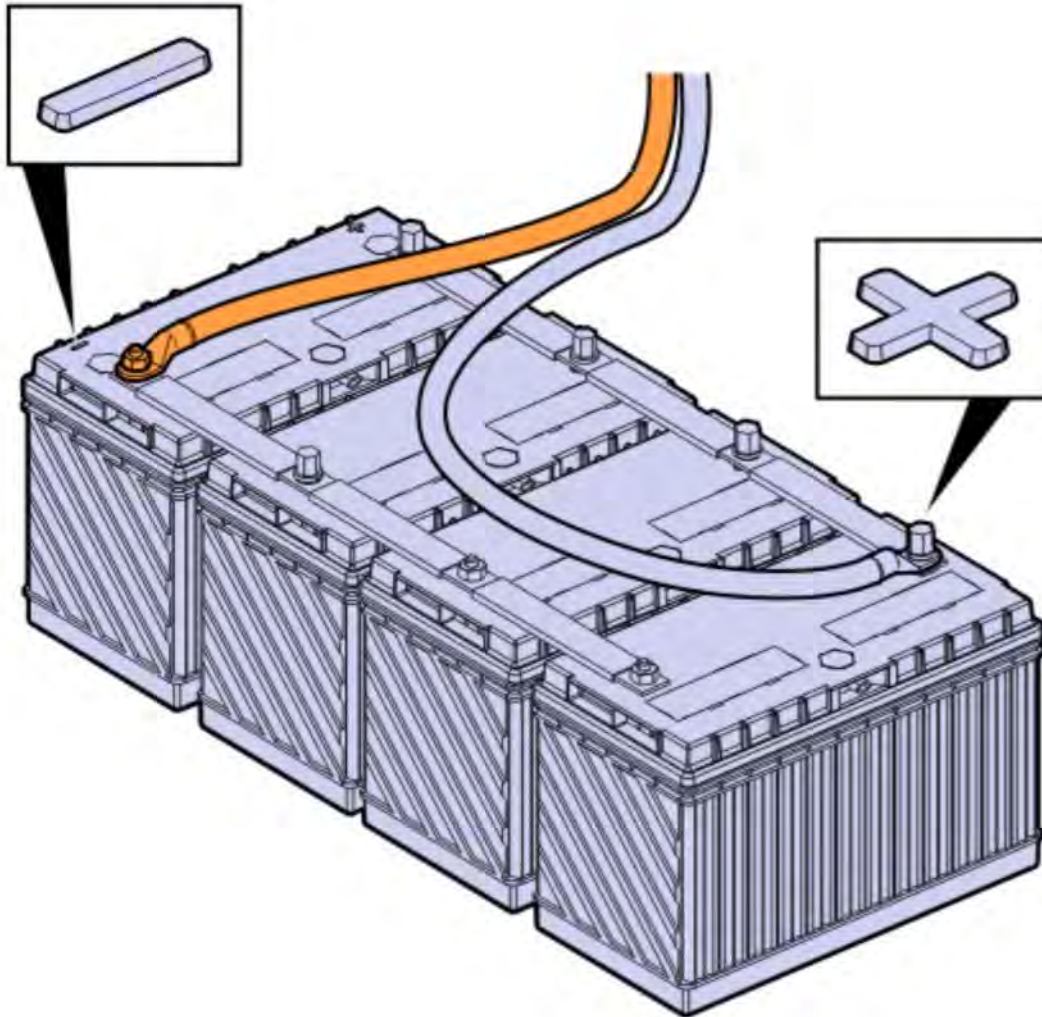

17. Clear any DTC codes.
18. Remove the wheel chocks.



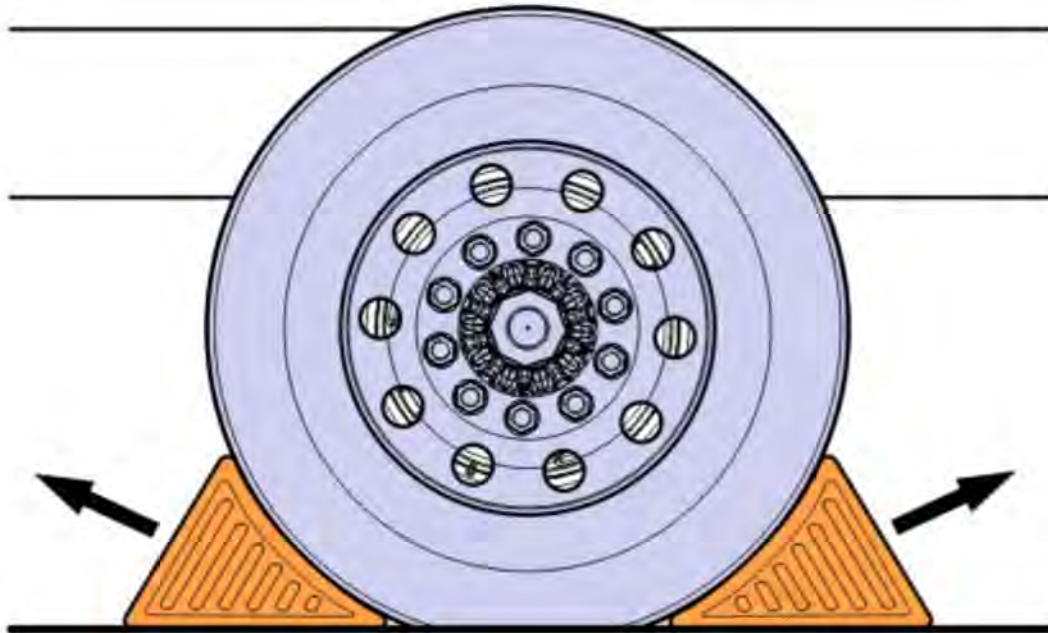

## Warranty information

### Reimbursement

<p>This repair may be eligible for reimbursement if a product failure was experienced within time and mileage limits of the applicable Warranty coverage. Reimbursement is obtained via the normal claim handling process.</p>	<p>UCHP Reimbursement</p>
<p>Claim Type (used only when uploading from the Dealer Bus. Sys.)</p>	<p>W</p>
<p>Labor Code</p>	
<p>Primary Labor Code (Exhaust Particulate Sensor, Repair)</p>	<p>2846-16-09-02</p>
<p>Causal Part</p>	<p>22946032</p>

## Issued by

### Technical Service