

**ATTENTION:**

- GENERAL MANAGER
- PARTS MANAGER
- CLAIMS PERSONNEL
- SERVICE MANAGER

IMPORTANT - All Service Personnel Should Read and Initial in the boxes provided, right.

© 2020 Subaru of America, Inc. All rights reserved.



QUALITY DRIVEN® SERVICE

**PRODUCT CAMPAIGN BULLETIN**

**APPLICABILITY:** 2019MY Crosstrek  
**SUBJECT:** Rear Seat Belt Webbing Locking

**NUMBER:** WRC-20R  
**DATE:** 04/01/20  
**NHTSA ID:** 20V-189  
**REVISED:** 07/06/22

**Please be advised the WRA-20 Customer Satisfaction Service Program for replacing the left and right rear seat belt assemblies in certain 2019 model year Crosstrek vehicles has been escalated to a safety recall. The new safety recall code for this action is WRC-20.**

**INTRODUCTION:**

Subaru of America, Inc. (Subaru) is recalling certain 2019MY Crosstrek vehicles to replace the LH and RH Rear Seat Lap-Shoulder Seatbelt Assemblies. The affected vehicles are equipped with rear seat belt assemblies with a dual locking mechanism; a primary G-sensor lock and a redundant webbing sensor lock. Due to improper installation of a pawl spring at the supplier, the redundant webbing sensor lock may become inoperative for some rear LH and RH seatbelts identified by the supplier. The primary G-sensor lock in these seatbelts is not affected and will remain fully functional.

**AFFECTED VEHICLES:**

Vehicles affected by the previous WRA-20 service program **which have not yet been repaired** will be included in this recall.

Model Year	Carline	Production Range	VIN Range
2019	Crosstrek	August 22, 2019 – September 13, 2019	K8384655 - KH393012

The WRA-20 coverage for 4,862 unrepaired vehicles has been expired, and the new WRC-20 coverage is now applicable to those vehicles. Coverage for all affected vehicles must be confirmed by using the Vehicle Coverage Inquiry function on subarunet.com. This information is now available. Any remaining, unsubmitted WRA-20 claims should be submitted as WRC-20 claims, as described in the claim reimbursement and entry procedures section of this bulletin.

**REASON FOR THIS RECALL**

Due to improper installation of a pawl spring at the supplier, the redundant webbing sensor lock may become inoperative for some rear LH and RH seatbelts identified by the supplier.

<p><b>CAUTION: VEHICLE SERVICING PERFORMED BY UNTRAINED PERSONS COULD RESULT IN SERIOUS INJURY TO THOSE PERSONS OR TO OTHERS.</b></p> <p>Subaru Service Bulletins are intended for use by professional technicians ONLY. They are written to inform those technicians of conditions that may occur in some vehicles, or to provide information that could assist in the proper servicing of the vehicle. Properly trained technicians have the equipment, tools, safety instructions, and know-how to do the job correctly and safely. If a condition is described, DO NOT assume that this Service Bulletin applies to your vehicle, or that your vehicle will have that condition.</p>	<p style="text-align: center;"><b>Subaru of America, Inc. is ISO 14001 Compliant</b></p> <p>ISO 14001 is the international standard for excellence in Environmental Management Systems. Please recycle or dispose of automotive products in a manner that is friendly to our environment and in accordance with all local, state and federal laws and regulations.</p>
--	--

*Continued...*

## SAFETY RISK

In the unlikely circumstance that the G-sensor lock unexpectedly fails to function, the seat belt assembly may not restrain the passenger properly, increasing the risk of injury.

## DESCRIPTION OF THE REMEDY

Subaru retailers will replace the LH and RH Rear Seat Lap-shoulder Seatbelt Assemblies.

## OWNER NOTIFICATION

Subaru expects to re-notify all potentially affected vehicle owners by first class mail on or about April 15, 2020. Owners with a valid email address on file with Subaru will also be notified by email.

## RETAILER RESPONSIBILITY:

***Please be advised that it is a violation of Federal law for a dealer to deliver a new motor vehicle covered by a recall under a sale or lease until the defect is remedied. Therefore, any Authorized Subaru Retailer failing to perform the applicable service procedures to correct all affected vehicles in their inventory prior to the vehicle being placed in service may be subject to civil penalties of up to \$21,000 per violation (i.e., for each vehicle), as provided in 49 CFR §578.6 and will also be in breach of the Subaru Dealer Agreement.***

Any vehicles listed in any recall/campaign that are in retailer stock must be:

- Immediately identified.
- Tagged or otherwise marked to prevent their delivery or use prior to repair.
- Repaired in accordance with the repair procedures outlined in the Product Campaign Bulletin

Retailers are to promptly follow the applicable service procedures, to correct all affected vehicles in their inventory (new, used, demo & SSLP). Additionally, whenever a vehicle subject to this recall is taken into retailer inventory necessary steps should be taken to ensure the recall correction has been made before selling or releasing the vehicle.

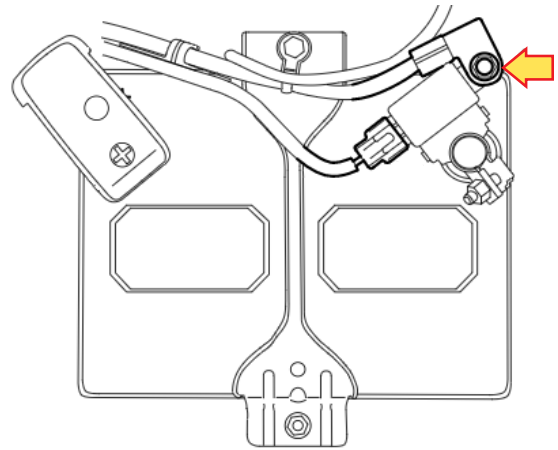

## PARTS INFORMATION:

Description	Part Number	Application	Position Code	ID Code
BELT ASSY R OUT 5DR	64660FL3609S*	Right Side Outer	5RH	HH
	(Alternative) 64660FL360VH**			
	64660FL3709S*	Left Side Outer	5LH	HH
	(Alternative) 64660FL370VH**			

*\*Parts for completing this product campaign must be ordered through PRIME.*

***\*\* If parts 64660FL3609S & 64660FL3709S are not in stock, place an order for the alternative parts listed.***

***Continued...***

**IMPORTANT:** Always confirm the part numbers of the replacement parts as shown in the table above to be sure the correct parts are ordered.

**NOTE:** Position Code and ID Code details are provided in the Service Procedure section below.

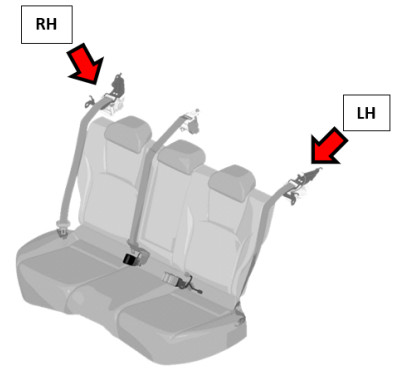

**SERVICE PROCEDURE:**

**IMPORTANT:** The use of **HAND TOOLS ONLY** is strongly recommended when performing these repairs. The use of air tools for bolt removal or installation may result in thread or weld nut damage. Weld nut damage may result in costly body panel replacement and would not be a matter for warranty. Work **CAREFULLY** using **hand tools only** along with a properly calibrated torque wrench to ensure all bolts are tightened and torqued to proper specification as part of this repair procedure.

This service procedure outlines replacement of both the left and right-hand outer seat belt assemblies. The center seat belt is **not** affected.

- Record all radio presets and navigation favorites (where applicable) for later reinstallation.
- Disconnect the negative battery cable from the 12V engine restart battery sensor (NEVER disconnect at the battery terminal itself) and always wait **at least 60** seconds before proceeding work to prevent any malfunction of the airbag pretensioner.
- When removing the negative battery cable from the battery sensor, **always support it and hold it in place with one hand** while loosening the retaining nut. Doing so will prevent battery sensor damage / deformation from unnecessary movement.
- **CAREFULLY** remove the necessary interior trim panels for seat belt access along with the rear seat cushion following the procedures in the applicable Service Manual and set them aside in a safe place.

**CAUTION:** The airbag system satellite safing sensor is located under the front center of the rear seat cushion. Be careful not to apply any strong impact force to the sensor while working in that area with the seat cushion removed.

- **After seat belt removal, mark the tag with a permanent marker** as shown here to distinguish the old part from the replacement (new) part. If by chance the old parts become confused with the new parts, check the date code to identify the new seat belt assemblies using the photo below as a guide.



*Continued...*

- Install the new outer seat belt assemblies in reverse order of removal. Confirm the new seat belt webbing is not twisted and can be pulled out and retracted smoothly.

**VERY IMPORTANT:** Confirm both the Emergency Locking Retractor (ELR) and Automatic Locking Retractor (ALR) operation of both new seat belts:

- **ELR:** Pull out a short length of belt and then tug it sharply to confirm it locks.
- **ALR:** Pull out the entire length of belt and confirm it retracts, ratchets, tightens and holds when pulled on (ALR).
- Latch BOTH belts and confirm all buckles function properly.
- **CAREFULLY** reinstall the interior trim panels and rear seat cushion in reverse order of removal following the procedures in the applicable Service Manual.
- Reconnect the negative (-) cable to the battery temperature sensor and torque the nut to **7.5 Nm (5.5 ft. lbs.)**. **NOTE:** Never exceed this torque specification as battery sensor damage may result. When installing the negative battery cable from or to the battery sensor, **always support it and hold it in place with one hand** while torquing the retaining nut. Doing so will prevent battery sensor damage / deformation from unnecessary movement.

**IMPORTANT REMINDERS:**

- After the battery is reconnected, initial diagnosis of the electronic throttle control is performed automatically. Always wait 10 seconds or more after turning the ignition switch ON before starting the engine.
- Reset the customer’s clock, radio presets and navigation favorites (where applicable).
- Confirm auto up / down operation of both front windows. Re-initialize if necessary (due to battery disconnect).
- If the customer had a phone paired to the infotainment system, re-pairing will be required. Assist the customer with this task if necessary.

**SERVICE PROGRAM IDENTIFICATION LABEL:**

Type or print the necessary information on a Campaign Identification Label. The completed label should be attached to the vehicle’s upper radiator support. Additional labels are available through normal parts ordering channels. The part number is **MSA6P1302**, which comes as one sheet of 20 labels.

Part Number	Applicability	Description	Order Quantity
MSA6P1302	All Models	Campaign Completion Labels (contains one sheet of 20 labels)	1

<b>SUBARU</b>
Campaign Code
<b>WRC-20</b>
COMPLETED
DIST./DEALER NO.
SERIAL NO.
<b>DO NOT REMOVE</b>

*Continued...*

## CLAIM REIMBURSEMENT AND ENTRY PROCEDURES:

Credit to perform this recall will be based on properly completed repair order information. Retailers may submit claims through Subarunet.com. Any remaining, unsubmitted WRA-20 claims should be submitted as WRC-20 claims, as described below.

Labor Description	Labor Operation #	Labor Time	Fail Code	Claim Type
WRC-20 LEFT & RIGHT REAR OUTER SEAT BELT REPLACEMENT	A191-124	0.8	WRC-20	RC

## IMPORTANT REMINDERS:

- SOA strongly discourages the printing and/or local storage of service information as previously released information and electronic publications may be updated at any time.
- Always check for any open recalls or campaigns anytime a vehicle is in for servicing.
- Always refer to STIS for the latest service information before performing any repairs.

*Continued...*

## OWNER NOTIFICATION LETTER

**URGENT**  
**IMPORTANT SAFETY RECALL**  
This notice applies to the VIN identified in  
the address section printed below



**Subaru of America, Inc**  
PO Box 9103  
Camden, NJ 08101-9877  
844-373-6614  
www.subaru.com

**Subaru Safety Recall WRC-20**  
**NHTSA ID 20V-189**  
**April 2020**

### Dear Subaru Owner:

This notice is sent to you in accordance with the National Traffic and Motor Vehicle Safety Act.

SUBARU OF AMERICA, INC. has decided that a defect, which relates to motor vehicle safety, exists in certain 2019 model year Crosstrek vehicles.

You received this notice because our records indicate that you currently own one of these vehicles. You previously received a letter informing you of a service program to correct this condition.

***This is to inform you that the service program has now been escalated to a safety recall.***

### REASON FOR THIS RECALL

Your vehicle is equipped with rear seat belt assemblies with a dual locking mechanism; a primary G-sensor lock and a redundant webbing sensor lock. A pawl spring may have been improperly installed by the seat belt manufacturer, which could affect the webbing sensor lock performance. In the event of a crash, the primary G-sensor lock is not affected and will properly restrain the passenger. However, if the G-sensor lock unexpectedly fails to function, the seat belt assembly may not restrain the passenger properly, increasing the risk of injury during a crash.

### WHAT SUBARU WILL DO

Subaru will replace the left and right rear seat belt assemblies in your vehicle at no cost to you.

### WHAT YOU SHOULD DO

Please contact your Subaru retailer (dealer) immediately for an appointment to have this repair performed, free of charge. As a precaution, please limit the use of the left and right rear passenger seats until this safety recall is completed.

### HOW LONG WILL THE REPAIR TAKE?

The actual time to perform this repair is less than one hour. However, it may be necessary to leave your vehicle for a longer period of time on the day of your scheduled appointment to allow your Subaru retailer flexibility in scheduling. For your convenience, your retailer may provide you with a loaner or rental vehicle, at no cost to you.

### OWNER INFORMATION

Government regulations require that recall notifications be sent to the last known owner of record. That information is based primarily on state registration and title data. If you are a lessor of this vehicle, federal regulations require you to forward this notice to your lessee within ten days.

If you have moved or sold your vehicle, please update this information online at [www.subaru.com](http://www.subaru.com), select 'Customer Support,' then select 'Address Update' or 'Ownership Update' from the "Quick Links" menu.

*Continued...*

## **IF YOU HAVE PREVIOUSLY PAID FOR A REPAIR**

If you have already paid for repairs associated with this coverage, you may be eligible for reimbursement. Reimbursement consideration will be based on the amount an authorized Subaru retailer in your area would charge for the same repair.

Please send the original service repair order, which has the name of the repair facility, date of repair, mileage at the time of repair, complete 17-digit vehicle identification number (VIN), and your name, with correct mailing address and telephone number to the address listed below.

**Subaru of America, Inc.  
Customer Advocacy Department, Attention: WRC-20 Recall  
P.O. Box 9103, Camden, NJ 08101-9877**

Please send original receipts only and retain a photocopy for your records. Please be assured that we will attempt to process your reimbursement request as quickly as possible, but it may take up to 60 days for this process to be completed.

## **IF YOU NEED FURTHER ASSISTANCE:**

To locate the nearest Subaru retailer, you can access our website at [www.subaru.com](http://www.subaru.com) and select 'Find a Retailer.'

For additional information, please go to: <http://www.wrc20.service-campaign.com>.

If you need additional assistance, please contact us directly:

- By e-mail: Go to [www.subaru.com](http://www.subaru.com) and select "Contact Us"
- By telephone: 1-844-373-6614  
Monday through Friday between 8:00 a.m. and 7:00 p.m. ET
- By U.S. Postal mail: Write us at Subaru of America, Inc.  
Attn: Customer Advocacy Department  
P.O. Box 9103, Camden, NJ 08101-987

To subscribe to the NHTSA Recall Notification email System, please go to:  
<https://www-odi.nhtsa.dot.gov/nhtsa/subscriptions>.

Please contact us immediately if the Subaru retailer fails or is unable to make the necessary repairs free of charge.

You may also contact the Administrator, National Highway Traffic Safety Administration (NHTSA), 1200 New Jersey Ave., SE, Washington, DC 20590 or call the toll-free Vehicle Safety Hotline at 1-888-327-4236 (TTY: 1-800-424-9153) or go to <http://www.safercar.gov> if you believe the Subaru retailer has failed or is unable to remedy your vehicle without charge within a reasonable amount of time.

Your continued satisfaction with your Subaru is important to us. Please understand that we have taken this action in the interest of your safety and your vehicle's proper operation. We sincerely apologize for any inconvenience this matter may cause and urge you to schedule an appointment as soon as possible.

Sincerely,  
Subaru of America, Inc.

***Notice to Lessors:*** Under Federal law the lessor of a vehicle who receives this letter must provide a copy of it to the vehicle lessee(s) within 10 business days from receipt. The lessor must also keep a record of the lessee(s) to whom this letter is sent, the date sent, and the applicable vehicle identification number (VIN). (For the purposes of this section, a lessor means a person or entity that in the last twelve months prior to the date of this notification has been the owner, as referenced on the vehicle's title, of any five or more leased vehicles. A leased vehicle is a vehicle leased to another person for a term of at least four months.)

***A subsidiary of SUBARU CORPORATION***