



SIB 01 05 22

2022-05-20

G11/G12 Front and Rear Air Suspension Struts: Ltd Wty Ext To 8 Yrs/80,000 Miles

This Service Information bulletin (Revision 01) replaces SI B01 05 22 **dated May 2022****What's New:**

- The flat rate labor operation numbers for replacing rear suspension air struts have been corrected
- Some content has been changed to a graphic format to improve the appearance

**MODEL**

E-Series	MY	Model Description	Production Dates
G11	Beginning with 2016	750i xDrive Sedan	August 11, 2015 to EOP
G12	Beginning with 2016	740Li Sedan	July 30, 2015 to EOP
G12	Beginning with 2017	740Li xDrive Sedan	February 09, 2016 to EOP
G12	Beginning with 2017	740Le xDrive Sedan	March 14, 2016 to EOP
G12	Beginning with 2016	750Li Sedan	October 19, 2015 to EOP
G12	Beginning with 2016	750Li xDrive Sedan	March 26, 2015 to EOP
G12	Beginning with 2017	ALPINA B7 xDrive	June 14, 2016 to EOP
G12	Beginning with 2017	M760Li xDrive Sedan	July 13, 2016 to EOP
G12	Beginning with 2020	745Le xDrive	September 19, 2018 to EOP

**Note:** The Model information above is for informational purposes only, it is not the only deciding factor.

**Eligible Vehicles**

To assist you in identifying those vehicles that have this component-specific extended limited warranty coverage, the DCSnet Warranty Vehicle Inquiry has been updated with the VIN and Component-specific Vehicle Comment shown below:

**Please see SI B01 05 22 (DC 37 11 90 01 00): For this vehicle, the front and rear air suspension strut assemblies limited warranty for defects in materials or workmanship has been extended to 8 years/80,000 miles as determined from the original in-service date. This coverage is subject to the same vehicle eligibility requirements, limitations, and exclusions that apply to the BMW New Vehicle Limited Warranty.**

**Note:** Before performing a repair and submitting a claim, first confirm that the vehicle has the above Notice of Limited Warranty Extension in the DCSnet Warranty Inquiry Vehicle Comments section.

If you have Extended Limited Warranty (ELW) eligibility and/or coverage questions, please contact the Warranty department through IDS by selecting Coverage, Policy, Coding Questions and Mileage Corrections prior to performing any repair.

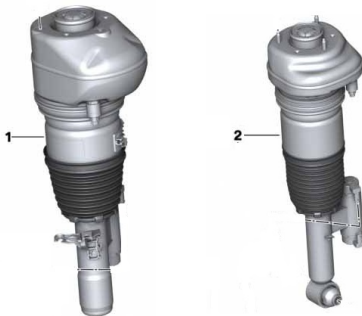
**SITUATION****Component-Specific Limited Warranty Extension**

For the eligible vehicles, BMW of North America, LLC (BMW NA) is extending the limited warranty for the vehicle's **front and rear air suspension strut assemblies (item # 1 Front and # 2 Rear, shown)** to:

- **8 years/80,000 miles, as determined by the vehicle's original in-service date.**

<b>Other air suspension system-related components/issues are excluded from this coverage.</b>
---

This component-specific limited warranty extension applies to defects in materials or workmanship.

This coverage is subject to the same vehicle eligibility requirements, limitations, and exclusions that apply to the BMW New Vehicle Limited Warranty for Passenger Cars and Light Trucks.

### **Important Note**

Driving over rough or damaged road surfaces, as well as debris, curbs and other obstacles can cause serious damage to wheels, tires, and suspension parts.

This is more likely to occur with low-profile tires that provide less cushioning between the wheel and the road.

Front and/or rear air suspension strut assembly repairs during the 4 year/50,000 mileage New Vehicle Limited Warranty or the extended limited warranty coverage that are required due to outside influence are not covered.

**Note: This bulletin is notice of a limited warranty extension. This is NOT a notice of a Recall or Service Action.**

There is no immediate repair required unless the BMW vehicle is currently experiencing this problem.

### **Customer Notification Letter**

Even though this is NOT a Recall, BMW NA is sending VIN-specific customer notification letters.

### **CAUSE**

For the Model vehicles listed above, the air suspension strut assemblies (front axle and/or the rear axle, left and/or right side) may experience a loss of air when the vehicle sits stationary for prolonged periods, causing the affected side(s) of the vehicle to drop or lean.

Additionally, acoustic type noises (rattling, cracking) may also occur and be heard while driving on rough road surfaces, over speed bumps or when frequent hard steering maneuvers are performed to enter and/or exit a parking space.

### **CORRECTION**

Follow the instructions in the PROCEDURE section.

### **PROCEDURE**

If a vehicle listed above arrives at your center with the issue described in the Cause above, perform diagnosis, and when required, replace the air suspension strut assemblies as applicable.

A wheel alignment check and adjustment procedure, after performing air suspension strut assembly replacement, only applies to the six (6) G12 models listed in the Claim Information section below.

The other air suspension system-related components are excluded from this coverage.

**Note:** When this repair is required to be performed, and it is determined that an air strut assembly on the axle being repaired has an accumulated mileage that is more than 100,000 km (62,140 miles), replace the air strut assemblies in sets on that axle (Both left and right).

### **PARTS INFORMATION**

#### **Special Replacement Part Ordering Procedure**

1. Use the customer's G11/G12 VIN to determine the applicable **air suspension strut** Electronic Parts Catalog (ETK/EPC) **Reference Only Part Numbers (1) that apply**.
2. From the table below, use this **ETK Reference Only Part Numbers (1)** to then determine and order the **air suspension strut** replacement **New Part Numbers (2)** which is to be used and invoiced to perform this repair.

### Air Suspension Strut Assembly Front Left/Right (New Part Numbers 37 10 N NNN NNN)

Front (37 10)	1. ETK Reference Only Part Numbers*				Order >	1. New Part Numbers*	Quantity
<Left	6 866 553	Or	6 899 037	Or	7 915 969	Order > 5 A4A 580	1
Right>	6 866 554	Or	6 899 038	Or	7 915 970	Order > 5 A4A 597	1
<Left					7 915 939	Order > 5 A4A 5A0	1
Right>					7 915 940	Order > 5 A4A 5A3	1
<Left			6 899 041	Or	7 915 941	Order > 5 A4A 5A4	1
Right>			6 899 042	Or	7 915 942	Order > 5 A4A 5B7	1
<Left	6 877 559	Or	6 899 043	Or	7 915 945	Order > 5 A4A 615	1
Right>	6 877 560	Or	6 899 044	Or	7 915 946	Order > 5 A4A 666	1
<Left			6 899 045	Or	7 915 949	Order > 5 A4A 6F7	1
Right>			6 899 046	Or	7 915 950	Order > 5 A4A 783	1

And/or:

### Air Suspension Strut Assembly Rear Left/Right (New Part Numbers 37 10 N NNN NNN)

Rear (37 10)	1. ETK Reference Only Part Numbers*				Order >	1. New Part Numbers*	Quantity
<Left			6 874 593	Or	7 915 953	Order > 5 A4A 7B0	1
Right>			6 874 594	Or	7 915 954	Order > 5 A4A 7B5	1
<Left			6 881 059	Or	7 915 957	Order > 5 A4A 7B8	1
Right>			6 881 060	Or	7 915 958	Order > 5 A4A 7B9	1

- \*When applicable, includes the corresponding part number supersessions.
- Only order these **parts in the quantities needed** to address customers' vehicles that have confirmed failures.

Additionally, other materials and small parts that are not specified above, such as fluids, lubricants, one-time use screws, nuts, and seals, which must be replaced or installed according to the ISTA repair instructions/ETK, must be selected from the Electronic Parts Catalogue, or other approved BMW resources, according to the respective vehicle type. Invoiced these items separately under the repair Defect Code listed in this bulletin.

## CLAIM INFORMATION

This component-specific limited warranty extension to 8 years/80,000 miles applies to eligible US-specification BMW vehicles that are registered, operated, and have their covered repair performed by an authorized BMW center in the United States (including Puerto Rico) for defects in materials or workmanship.

This coverage is subject to the same vehicle eligibility requirements, limitations, and exclusions that apply to the BMW New Vehicle Limited Warranty for Passenger Cars and Light Trucks.

**The existing limited warranty coverage for the whole vehicle and other components has not changed.**

This coverage supersedes the coverage that is provided under the BMW Certified Pre-Owned Program or any BMW Group Vehicle Service Contract that applies to the vehicle.

Should this component fail again, it is covered by the remaining portion of the extended limited warranty coverage period.

### Non-Qualifying Repairs

Repairs performed on ineligible vehicles, eligible vehicles operated and repaired outside the United States and Puerto Rico, and/or the diagnosis and repair of issues beyond the scope of this component-specific coverage, or that are due to outside influences, or any other unrelated issues are not covered by this limited warranty extension. This exclusion also applies to repairs that were performed using (including those repairs that result from using) non-genuine BMW parts and/or used BMW passenger car or light truck parts.

### Qualifying Repairs – Claim Submission

<b>Defect Code:</b>	<b>3711900100</b>	<b>G11 G12 Front and rear-axle air suspension strut</b>
---------------------	-------------------	---

Refer to AIR for the corresponding flat rate unit (FRU) allowances for the model vehicle being repaired except for as otherwise noted below for the G12 ALPINA B7 xDrive.

<b>Labor Operation</b>	<b>Description</b>	<b>Labor Allowance</b>
00 00 006	Performing vehicle test (with vehicle diagnosis system – checking faults) <b>(Main work)</b>	Refer to AIR
Or:		
00 00 556	Performing vehicle test (with vehicle diagnosis system – checking faults) <b>(Plus work)</b>	Refer to AIR
And:		
61 21 528	Support voltage of the vehicle electrical system / recharge vehicle electrical system battery	Refer to AIR
And, as necessary:		
61 00 006**	Performing vehicle diagnosis – test module	Work time (WT)
Or		
00 58 500**	Diagnosis Worktime Flat Rate (See below)	2 FRU
And:		
37 00 501	Draining/filling air spring system	Refer to AIR

If you are using a Main labor code for another repair, use the Plus code labor operation 00 00 556 instead of 00 00 006, or exclude (including 61 21 528) when the Vehicle Test is included in another repair.

Work time labor operation codes 61 00 006 and 00 58 500 are not considered Main labor operations.

And for:

<b>Front Air Suspension Strut Assembly Replacements</b>
---

As applicable:

Labor Operation	Description – Except as noted below	Labor Allowance
37 11 501	Replacing <b>front left or right</b> air suspension	Refer to AIR
Or:		
37 11 505	Replacing <b>both</b> air suspensions, <b>front</b>	Refer to AIR

Or, as applicable:

Labor Operation	Description - G12 RWD: 740Li Sedan and 750Li Sedan	Labor Allowance
37 11 509	Replacing <b>front left or right</b> air suspension	Refer to AIR
Or:		
37 11 507	Replace both air suspensions, <b>front</b>	Refer to AIR

Or, as applicable:

Labor Operation	Description - G12: ALPINA B7 xDrive and see below	Labor Allowance
37 99 000	Work time for replacing <b>front left or right</b> air suspension	11 FRU
Or:		
37 99 000	Work time for replacing <b>both</b> air suspensions, <b>front</b>	22 FRU

And, **only** for the following models (Including the ALPINA B7 xDrive, See WT 37 99 000 Below):

Series	Model Description	Series	Model Description	Series	Model Description
G12	740Li xDrive Sedan	G12	750Li xDrive Sedan	G12	745Le xDrive
G12	740Le xDrive Sedan	G12	M760Li xDrive Sedan	G12	ALPINA B7 xDrive

In conjunction with front air strut assembly replacements:

Labor Operation	Description	Labor Allowance
32 00 595	Kinematics Diagnosis System wheel alignment with ride height measurement <b>without loading</b> the vehicle	Refer to AIR
And:		
32 00 601	Adjusting toe-in on front axle	Refer to AIR

And/or:		
32 00 621	Adjusting rear axle and renewing with eccentric screws	Refer to AIR
Or:		
32 00 620	Adjusting rear axle (Eccentric screws already replaced)	Refer to AIR
And, if applicable		
32 00 650	Additional work for integral active steering (HSR)	Refer to AIR

Or when the above wheel alignment labor operations are not available in AIR for the APLINA B7 xDrive:

**ALPINA B7 xDrive: Work Time (WT) Labor Operation 32 99 000 Calculation (RO and Claim Comments Required)**

Labor Operation	Description	Labor Allowance
32 99 000	Kinematics Diagnosis System wheel alignment with ride height measurement <b>without loading</b> the vehicle	16 FRU
<b>And:</b>		
32 99 000	Adjusting toe-in on front axle	3 FRU
<b>And/or:</b>		
32 99 000	Adjusting rear axle and renewing with eccentric screws	7 FRU
<b>Or:</b>		
32 99 000	Adjusting rear axle (Eccentric screws already replaced)	11 FRU
<b>And, if applicable:</b>		
32 99 000	Additional work for integral active steering (HSR)	1 FRU

Claim work time labor operation **32 99 000 one-time** for the total FRU allowance that applies and itemize the WT FRU amount claimed on the RO and in claim comment section.

And/or for:

<b>Rear Air Suspension Strut Assembly Replacements</b>
--

As applicable:

Labor Operation	Description - Except as noted below	Labor Allowance
37 12 570	Replacing <b>rear left or right</b> air suspension	Refer to AIR
Or:		
37 12 580	Replacing <b>both</b> air suspensions, <b>rear</b>	Refer to AIR

Or, as applicable:

Labor Operation	Description - G12: ALPINA B7 xDrive and see below	Labor Allowance
37 99 000	Work time for replacing <b>rear left or right</b> air suspension	22 FRU
Or:		

37 99 000	Work time for replacing <b>both</b> air suspensions, <b>rear</b>	32 FRU
-----------	--	--------

### ALPINA B7 xDrive: Work Time (WT) Labor Operation 37 99 000 Calculation (RO and Claim Comments Required)

A. Front Only	FRT FRU	FRT FRU	FRT FRU	FRT FRU
Replacing one (1) front	11 (1 total)			11 (1 total)
Replacing both (2) fronts		22 (2 total)	22 (2 total)	
B. Rear Only	RR FRU	RR FRU	RR FRU	RR FRU
Replacing one (1) rear	22 (1 total)		22 (1 total)	
Replacing both (2) rears		32 (2 total)		32 (2 total)
C. A and B, when applicable	32 (2 total)	54 (4 total)	44 (3 total)	43 (3 total)

Claim work time labor operation **37 99 000 one time** for the total FRU allowance that applies and itemize the WT FRU amount claimed on the RO and in claim comment section

\*\*Based on which one applies to your center, please refer to **SI B01 01 20** or **B01 07 20** for the applicable procedure for documenting, claiming, and explaining, on the RO and in the claim comments, your diagnosis work time (WT), job/repair work time (WT), and the vehicle repairs your center performed, unless otherwise required by State law.

### Previous Customer-Pay Repairs – Limited Warranty Extension Reimbursement

Under this extended limited warranty, BMW of North America, LLC (BMW NA) will provide reimbursement for qualifying customer-pay repairs that were performed on an eligible vehicle **prior** to the release of this component-specific limited warranty extension.

Customer-pay repairs are subject to the same vehicle eligibility requirements, limitations, and exclusions that apply to the BMW New Vehicle Limited Warranty for Passenger Cars and Light Trucks.

### Repairs That Do Not Qualify for Reimbursement

Repairs performed on ineligible vehicles, eligible vehicles operated and repaired outside the United States and Puerto Rico, and/or the diagnosis and repair of issues beyond the scope of this component-specific coverage, or that are due to outside influences, or any other unrelated issues are not covered by this limited warranty extension. This exclusion also applies to repairs that were performed using (including those repairs that result from using) non-genuine BMW parts and/or used BMW passenger car or light truck parts.

### Requesting Reimbursement for a Previous Repair That Qualifies

For a customer to request reimbursement for a qualifying customer-pay repair performed either by an authorized BMW center or independent repair shop located in the United States (including Puerto Rico), please have him/her submit his/her reimbursement request online at [www.BMW-RP.com](http://www.BMW-RP.com) under the following reference:

- B-ELWR Air Struts 8Y80M (F/R)

### Reimbursement Request Procedure

The online process is initiated by attaching/sending PDF files of the supporting documentation for the prior repair.

The letter also includes alternative methods to request reimbursement, either through the mail or by fax as described below:

BMW Customer Reimbursement Center  
Attention: B-ELWR Air Struts 8Y80M (F/R)

P.O. Box 54067  
Hurst, Texas 76054

Fax number: 877-434-2992

**Please allow 4-6 weeks for processing your request.**

Should you have any questions concerning this reimbursement process, please call 1-844-857-0341.

**QUESTIONS REGARDING THIS BULLETIN**

Technical inquiries	Submit feedback at the top of this bulletin
Warranty inquiries	To submit feedback for the CLAIMS section of this bulletin: Submit an IDS ticket to the Warranty Department, or use the chat available in the Warranty Documentation Portal
Parts inquiries	Submit an IDS ticket to the Parts Department

Supporting Materials

[picture\\_as\\_pdf B010522 Customer Letter.pdf](#)





**BMW**

47911 HALYARD DRIVE  
STE. 200  
PLYMOUTH, MI 48170  
DO NOT MAIL REPAIR ORDERS TO THIS ADDRESS

027622-T1-P1-000001

SAMPLE  
SAMPLE  
SAMPLE



May 2022

This **“Important Limited Warranty Information,”** effective with the date listed above, applies to the BMW model with the Vehicle Identification Number (VIN) of **WBA7U2C00L** [REDACTED]

Dear BMW Owner/Lessee:

BMW is committed to delivering the ultimate in product satisfaction to our customers.

Towards that end, BMW is extending the limited warranty for the:

- **Front and Rear Air Suspension Strut Assemblies (G11/G12)**

On the above-referenced vehicle to:

- **8 years/80,000 miles, as determined by your vehicle’s original in-service date.**

This “component-specific” limited warranty extension applies to defects in materials or workmanship. This coverage is subject to the same vehicle eligibility requirements, limitations, and exclusions that apply to the BMW New Vehicle Limited Warranty for Passenger Cars and Light Trucks.

**This is a notice of a “limited warranty extension.” It is not a notice of a Recall or Service Action.**

If a repair to this component is required, please contact your nearest authorized BMW center in the United States or Puerto Rico to schedule an appointment.

Your BMW center will confirm your vehicle’s eligibility and review the scope of the repairs to determine if this extended limited warranty coverage applies. After vehicle inspection and diagnosis, eligible repair work will be performed by the authorized BMW center free of charge.

Repairs performed on ineligible vehicles, eligible vehicles operated and repaired outside the United States and Puerto Rico, and/or the diagnosis and repair of issues beyond the scope of this component-specific coverage or that are due to outside influences, or any other unrelated issues are not covered by this limited warranty extension. This exclusion also applies to repairs that were performed using (including those repairs that result from using) non-genuine BMW parts and/or used BMW passenger car or light truck parts.

The integrity of our products is essential to BMW’s success and our customers’ trust. We are determined to exceed your expectations and hope this warranty extension further enhances your ownership experience.

Sincerely,

BMW of North America, LLC

B-ELW Front and Rear Air Suspension Strut Assemblies (G11/G12) 8Y80M (2022) SAMPLE

**Company**  
BMW of North America, LLC  
BMW Group Company

**Mailing Address**  
PO Box 1227  
Westwood, NJ  
07675-1227

**Website**  
[www.bmwusa.com](http://www.bmwusa.com)



## Previous Customer-Pay Repairs – Limited Warranty Extension Reimbursement

### BMW of North America, LLC

May 2022

**VIN WBA7U2C00L** [REDACTED]

For the BMW model with the Vehicle Identification Number (VIN) listed above, BMW of North America, LLC (“BMW NA”) will reimburse “qualifying customer-pay repairs” that were performed prior to the release of this component-specific limited warranty extension.

Customer-pay repairs are subject to the same vehicle and coverage eligibility requirements, exclusions and limitations that apply to the BMW New Vehicle Limited Warranty for Passenger Cars and Light Trucks.

### Repairs That Do Not Qualify for Reimbursement

Repairs performed on ineligible vehicles, eligible vehicles operated and repaired outside the United States and Puerto Rico, and/or the diagnosis and repair of issues beyond the scope of this component-specific coverage or that are due to outside influence, or any other unrelated issues are not covered by this limited warranty extension. This exclusion also applies to repairs that were performed using (including those repairs that result from using) non-genuine BMW parts and/or used BMW passenger car or light truck parts.

### Requesting Reimbursement for a Previous Repair that Qualifies

If you previously had a “qualifying customer-pay repair” performed either by an authorized BMW center or independent repair shop located in the United States (including Puerto Rico), please submit your reimbursement request “online” at [www.BMW-RP.com](http://www.BMW-RP.com) under the following reference:

**Covered Component Code**  
B-ELWR Air Struts 8Y80M F/R

To initiate the online process, you will be asked to attach PDF files of the required documentation as outlined in the reimbursement checklist on the next page.

Alternatively, you may mail or fax your request, and documentation to:

BMW Customer Reimbursement Center  
Attention: B-ELWR Air Struts 8Y80M F/R  
P.O. Box 54067  
Hurst, TX 76054

Fax number: 877-434-2992

**Please allow 4-6 weeks for processing your request.**

Should you have any questions concerning this reimbursement process, please call 1-844-857-0341.



# Front and Rear Air Suspension Struts Assemblies (G11/G12): Limited Warranty Extension to 8 Years/80,000 Miles

## Previous Customer-pay Repair Reimbursement – Documentation Checklist

### BMW of North America, LLC

Reimbursement is available to the BMW Owner/Lessee who incurred the expense.

When submitting a reimbursement for a previous repair, please provide **legible copies** of the following documentation and include your VIN, name, address and your preferred contact telephone number(s):

#### Repair Order (RO) or Invoice

This document should include the following information:

- Customer name and address
- Vehicle Identification Number (“VIN”)
- The date of repair
- The mileage when the repair was performed
- Itemized breakdown of the labor charges for all repairs\* including diagnosis
- Itemized breakdown of the parts, including any miscellaneous items, billed for all repairs\*

\*For repair orders containing multiple repair line items, only the specific line-item expenses that relate to the component that is covered by this extended limited warranty will be considered for reimbursement.

#### Proof of Payment

Please provide a copy of at least **one** of the following items as valid proof of payment:

- Repair order (RO)/invoice stamped and dated as “PAID”
- Copy of a cancelled check
- Copy of a signed credit/debit card receipt
- Copy of a credit/debit card statement

#### Determining if an eligible vehicle’s repair qualifies for reimbursement:

Please use the following questions to review your repair order documentation prior to submitting a reimbursement request:

1. Why was the vehicle brought into the repair facility?
2. What was the repair facility's diagnosis?
3. What did the repair facility do to correct the concern, and does it qualify?



## Front and Rear Air Suspension Struts (G11/G12): Limited Warranty Extension to 8 Years/80,000 Miles

### Frequently Asked Questions (FAQ)

1. **With the release of this notification, which BMW Group US models are potentially eligible for this component-specific Limited Warranty Extension?**

E-Series	Beginning MY	Model Description
G11	2016	750i xDrive Sedan
G12	2016	740Li Sedan
G12	2017	740Li xDrive Sedan
G12	2017	740Le xDrive Sedan
G12	2016	750Li Sedan
G12	2016	750Li xDrive Sedan
G12	2017	ALPINA B7 xDrive
G12	2017	M760Li xDrive Sedan
G12	2020	745Le xDrive

2. **What is the specific issue with the Air Suspension Strut Assemblies?**

For the Model vehicles listed above, the air suspension struts (left and/or right side, front axle and/or the rear axle) may experience a loss of air when your vehicle sits stationary for prolonged periods, causing the affected side(s) of the vehicle to drop or lean.

Additionally, acoustic type noises (rattling, cracking) may also occur and be heard while driving on rough road surfaces, over speed bumps or when frequent hard steering maneuvers are performed to enter and/or exit a parking space.

3. **What should I do if I notice a similar condition in my vehicle?**

Please contact an authorized BMW center in the United States (including Puerto Rico) to have your vehicle inspected, and as necessary, repaired.

4. **How will my vehicle be repaired?**

If it is determined that the air suspension strut assemblies in your vehicle are causing the issues described above due to a defect materials or workmanship, the affected air strut assembly will be replaced free of charge under the terms of this 8 year/80,000-mile extended limited warranty coverage.

**Note:** Any other air suspension system-related issues that are beyond the scope of this component-specific extended coverage and/or that are due to outside influences are excluded from this coverage.

