

June 15, 2022

Version 1

Product Update: 2022 CR-V EPS Gearbox Replacement

AFFECTED VEHICLES

Year	Model	Trim	VIN Range
2022	CR-V	ALL	Check iN VIN status for eligibility
2022	CR-V Hybrid	ALL	Check iN VIN status for eligibility

BACKGROUND

Due to a manufacturing issue, a short circuit in the EPS torque sensor may cause unstable power supply. This may lead to a loss of steering assistance and turn the EPS warning light ON (DTC C1423-14, Torque Sensor Power Source Circuit Malfunction).

CUSTOMER NOTIFICATION

Owners of affected vehicles will be sent a notification of this campaign.

Do an iN VIN status inquiry to make sure the vehicle is shown as eligible.

Some vehicles affected by this campaign may be in your used vehicle inventory. Repair these vehicles before they are sold.

CORRECTIVE ACTION

Remove the EPS Gearbox Assembly and replace/install a new gearbox while maintaining the original EPS Motor/Control Unit.

PARTS INFORMATION

Part Name	Part Number	Quantity
CR-V Petrol: EPS Hardware Kit	06530-TLA-305	1
CR-V Petrol: EPS Gearbox Assembly	53640-TLB-305	1
CR-V Hybrid: EPS Hardware Kit	06530-TPG-305	1
CR-V Hybrid: EPS Gearbox Assembly	53640-TPG-305	1

CUSTOMER INFORMATION: The information in this bulletin is intended for use only by skilled technicians who have the proper tools, equipment, and training to correctly and safely maintain your vehicle. These procedures should not be attempted by "do-it-yourselfers," and you should not assume this bulletin applies to your vehicle, or that your vehicle has the condition described. To determine whether this information applies, contact an authorized Honda automobile dealer.

WARRANTY CLAIM INFORMATION

Operation Number	Description	Flat Rate Time	Defect Code	Symptom Code	Template ID	Failed Part
5131M3	Petrol with 2WD: Replace the EPS gearbox. Includes steering neutral position re-learn, DTC Clear and alignment.	2.5 hr	6HE00	MCA00	A22011A	53620-TLA-A30
5131M3A	Petrol with 4WD - Add	0.4 hr	6HE00	MCA00	A22011B	53620-TLA-A30
5131M3	Hybrid: Replace the EPS gearbox. Includes steering neutral position re-learn, DTC Clear and alignment.	2.4 hr	6HE00	MCA00	A22011C	53620-TPG-A00

REPAIR PROCEDURE

Refer to the Service Information (SIS) for complete Power Steering (P/S) gearbox removal repair procedure.

1. Disconnect the 12-volt battery terminal.
2. Keep the vehicle elevated at a proper height for the procedure.
3. Remove the front wheels.
4. Disconnect the steering joint.
5. Disconnect the tie-rod end ball joint from both sides.

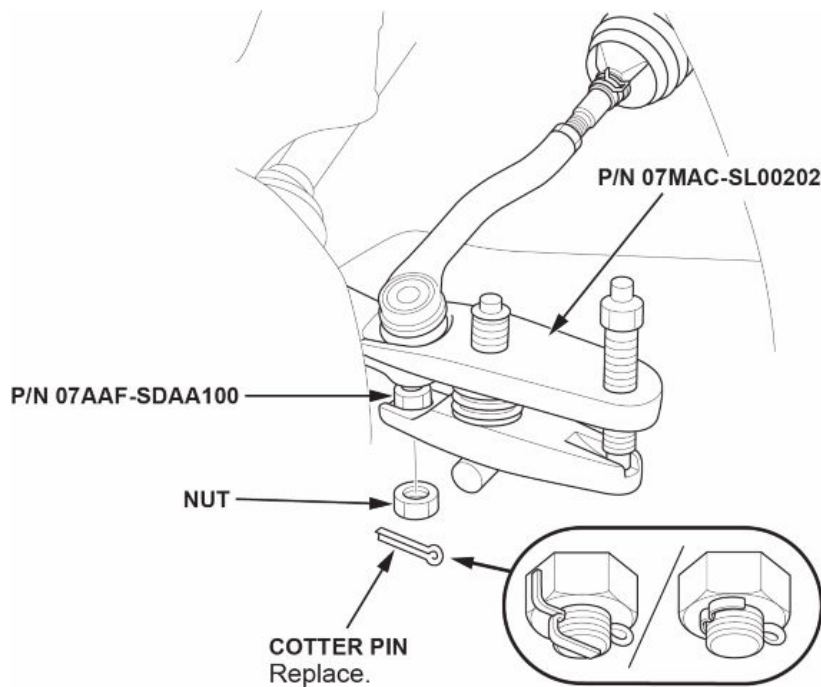

6. Remove the undercover from the engine.

7. Disconnect the EPS harness connectors.

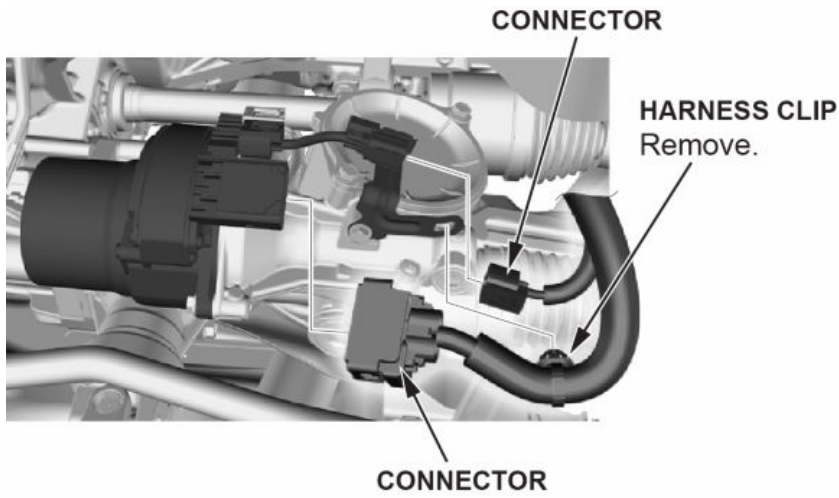

8. Disconnect the stabilizer links located on top.

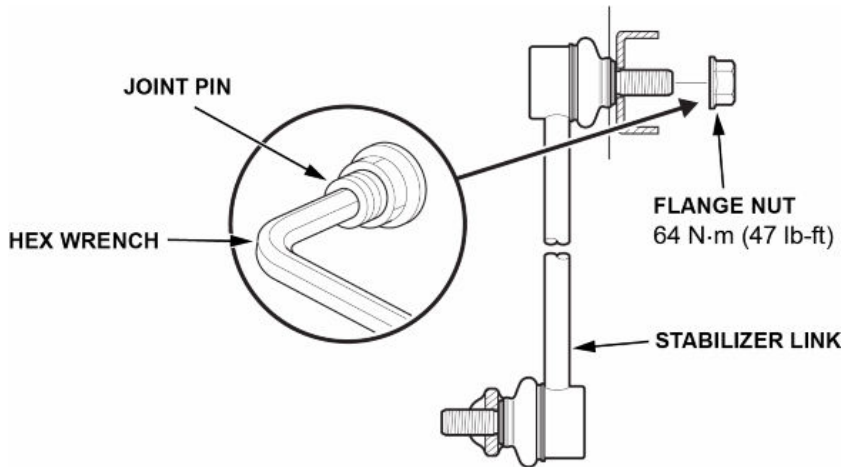

NOTE: During the subframe installation process, position the stabilizer links in vertical position for easier installation.

9. Disconnect the front lower arms.

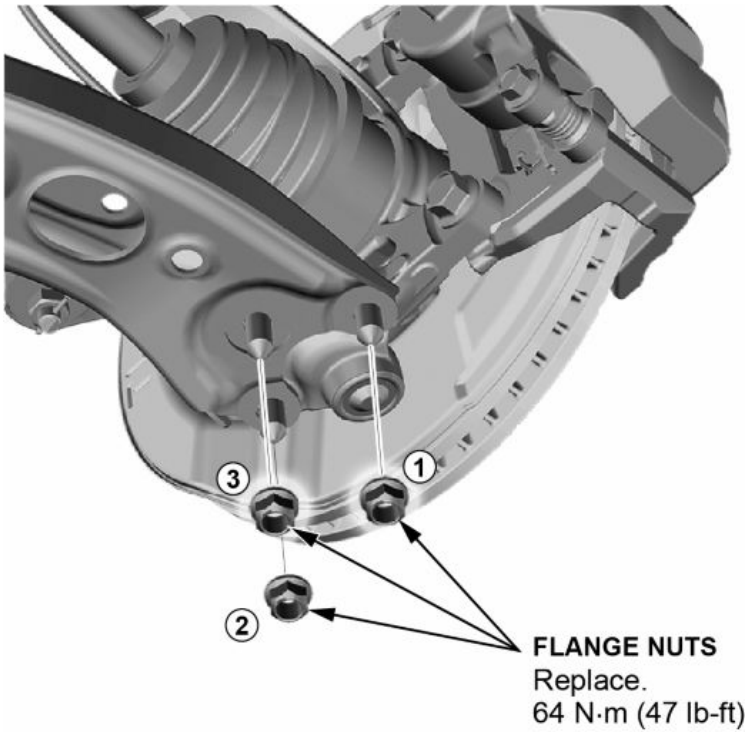

NOTE: During reassembly, loosely install the new Flange Nuts (A), then tighten them to the specified torque in the numbered sequence shown.

10. Excluding Hybrid: Remove exhaust pipe A.

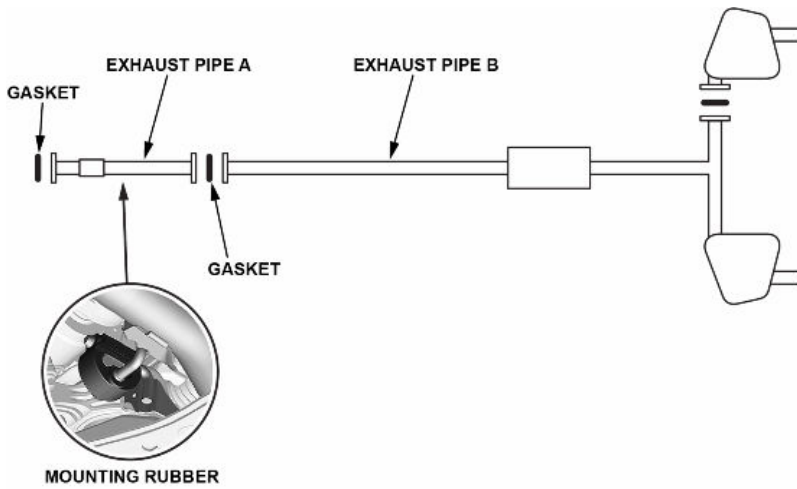

11. Petrol 4WD Only: Remove the propeller shaft.

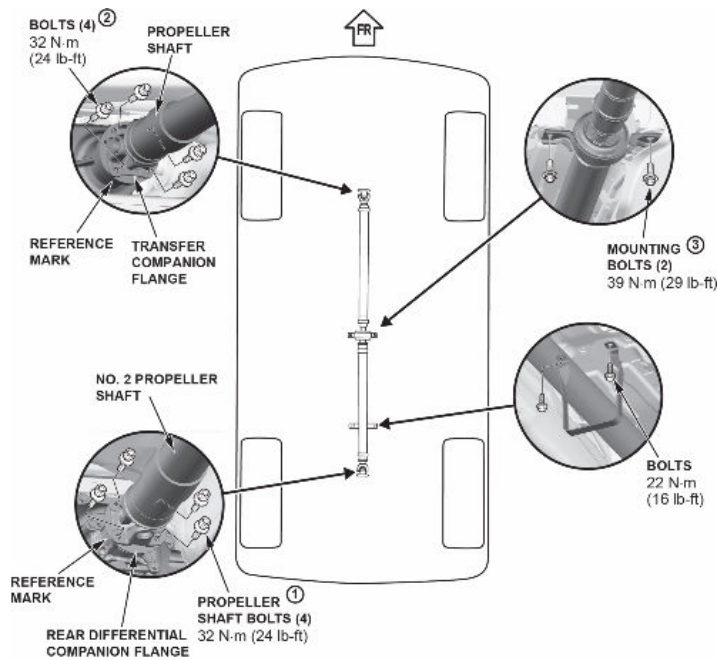

12. Remove the front subframe brace.

NOTE: After removing the front subframe mounting bolts, be sure to replace them with new ones.

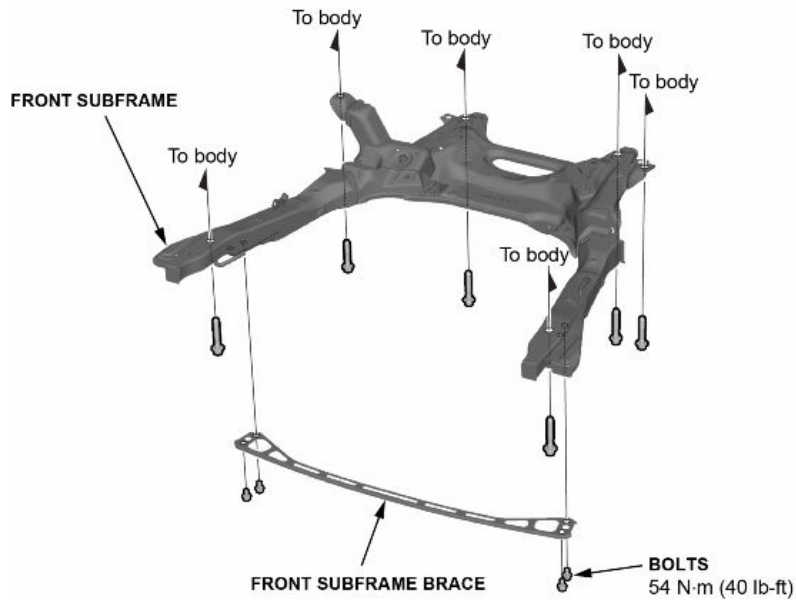

13. Remove the lower torque rod and compliance bushing.

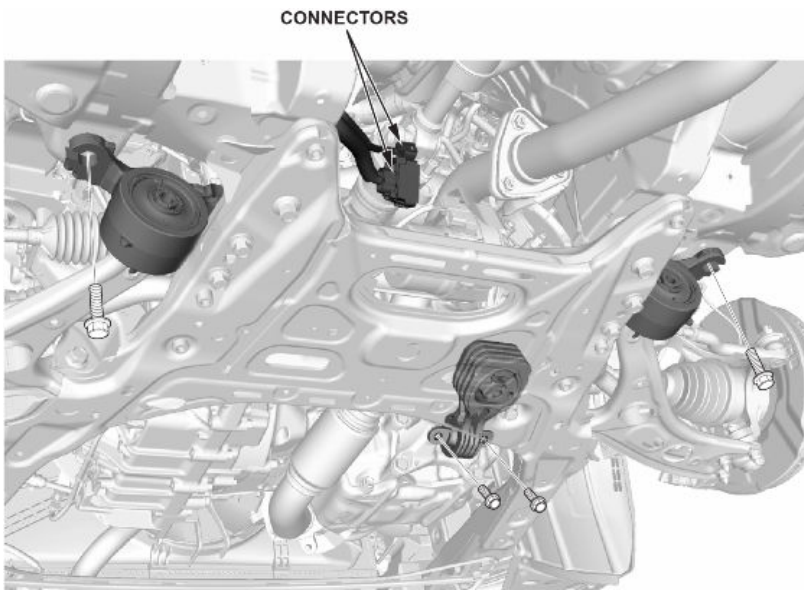

14. Remove the front lower arm mounting bolt.

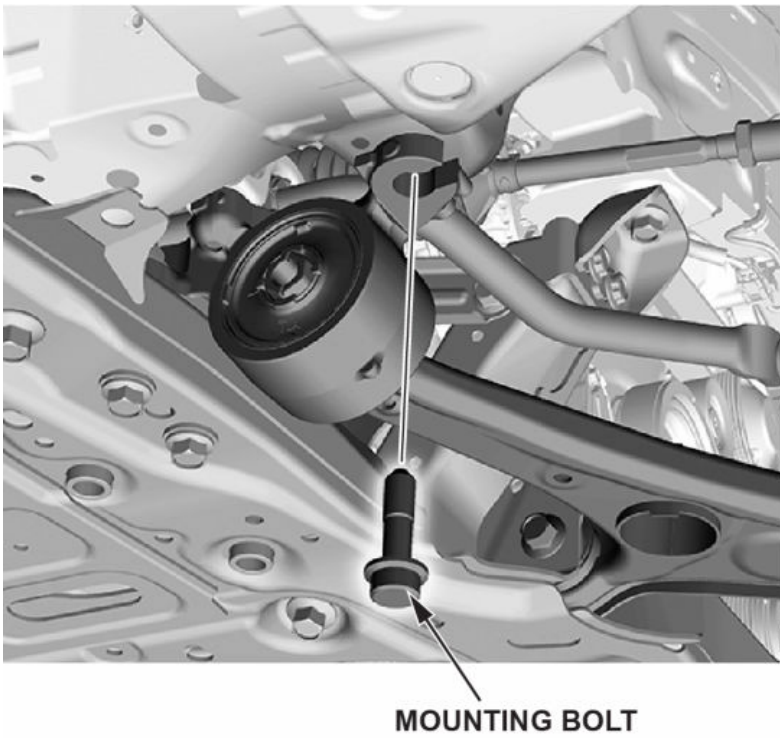

15. Drop down the front subframe.

16. Remove the front stabilizer bar bushing holder.

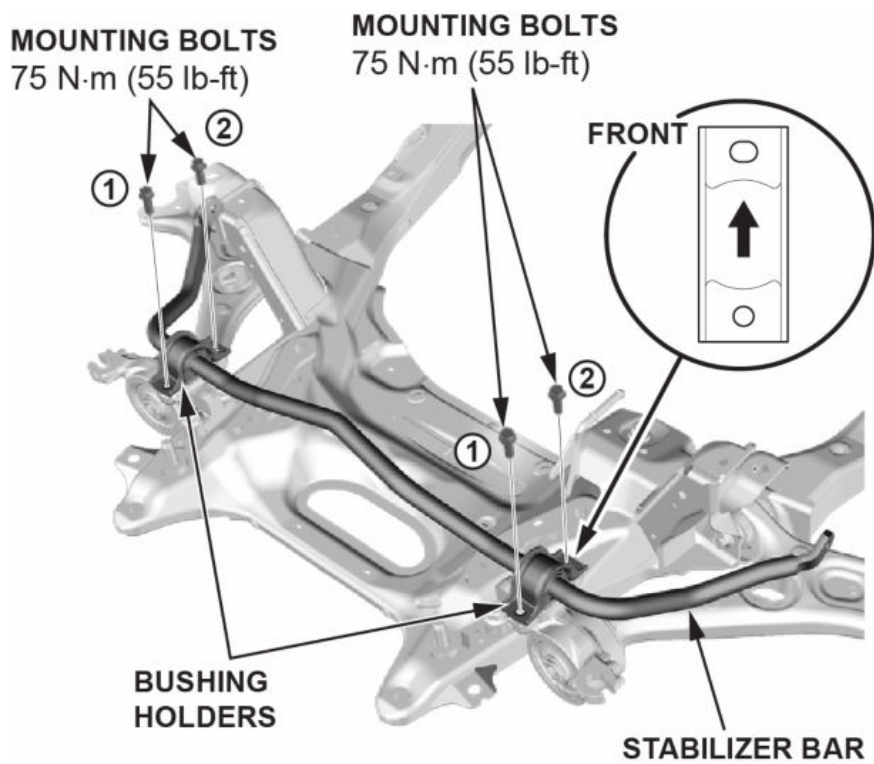

17. Remove the pinion shaft grommet.

18. Remove the steering gearbox.

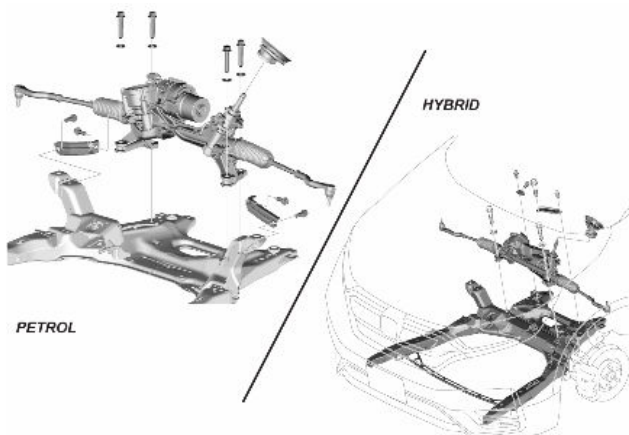

19. Mark out the steering gearbox bar code.

20. Hybrid Only: Remove the heat baffle.

21. Hybrid Only: Remove the EPS harness.

22. Remove the EPS motor.

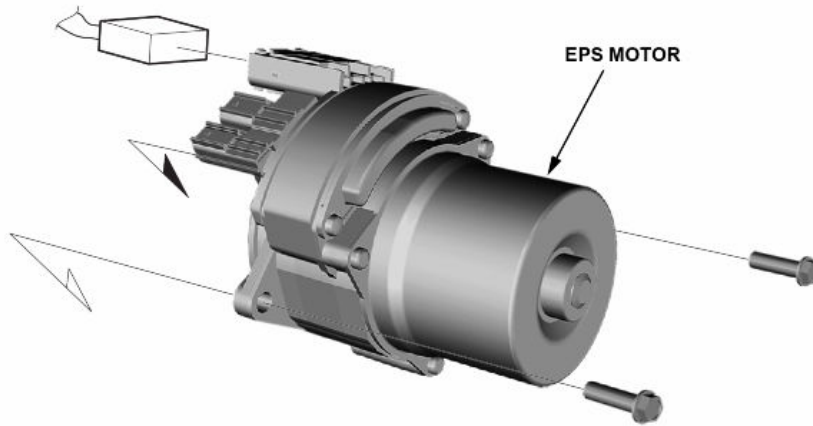

23. Install the EPS motor onto the new P/S gearbox kit, which includes the following parts:

Description	Quantity
O-Ring, Motor (79.4 x 3.1)	1
Bolt, Flange (8 x 30)	1
Bush, Motor	1
Rubber, Bush	1

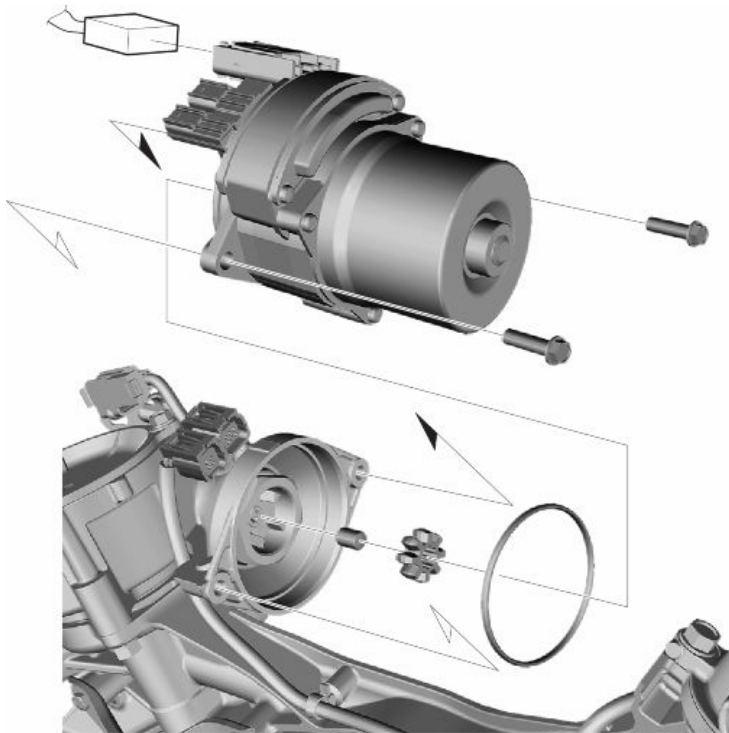

24. Install the new P/S gearbox kit (with EPS motor) and reassemble in the reverse order of removal.

END