



Mack Haldex Slack Adjuster Hitting Shock

Service Category Service Department

Section Example 514

Technician Skill Level C

Market North America

Applicability

Mack

Model Years	Models
2022-2023	AN, GR

Introduction

Mack truck has determined that on certain AN and GR model trucks the slack adjuster adjusting bracket could contact the shock causing damage. There is now a new slack adjuster to correct this issue. Follow the instructions below to replace the slack adjusters on the rear/rear drive axle with new ones and adjust.

Production Change Information

This bulletin applies to vehicles built within the specified production changes below.

Brand	Engine	VECU Level	Starting Build Date	Ending Build Date
Mack	MP-7, MP-8	EM-EC01, USA-17, USA-21	13-December-2021	16-May-2022

Warranty Information

This repair is covered by an authorized Service Program. Reimbursement is obtained through the normal claim handling process.		
Claim Type (used only when uploading from the Dealer Bus. Sys.)		B
Main Labor Code	Description	Hours
5141-03-02-04	Slack Adjuster, Replacement 0.5 x 2	1.0
Causal Part	25156842	
SCC Authorization Code	S7648	
Expiration Date	June 30 2023	

Mack Haldex Slack Adjuster Hitting Shock

Parts Information

Part Number	Part Description	Quantity
21446722	Slack adjuster	2

Required Tools & Equipment

N/A

Calibration Information

N/A

Repair Procedure

1. Chock the wheels.
2. Cage the brake chamber on the rear/rear axle.
3. Remove pin from the clevis.
4. Back off the slack adjuster.

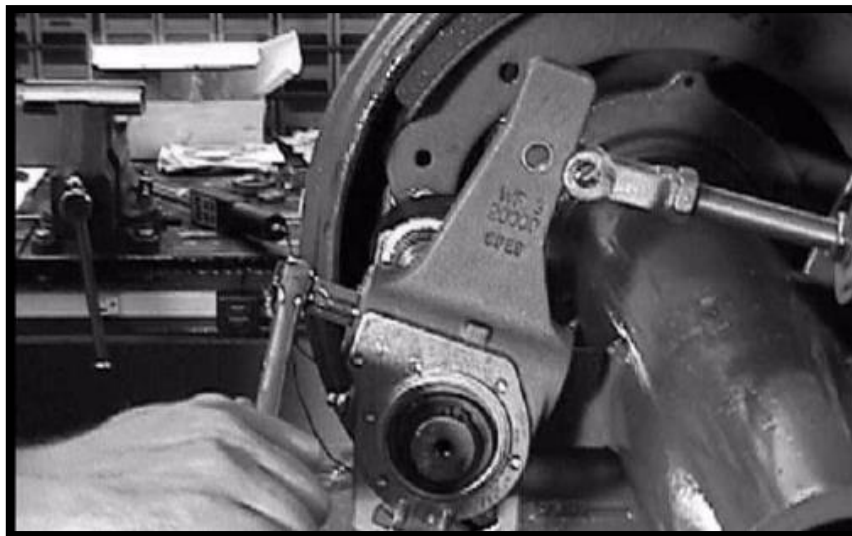

5. Remove snap ring securing the slack adjuster to the s-cam and remove slack adjuster.

Mack Haldex Slack Adjuster Hitting Shock



6. Loosen and discard the slack adjuster adjusting anchor bracket.
7. Install the new anchor bracket provided with the slack on the s-cam tube and hand tighten.
8. Install new slack adjuster (21446722) and secure with snap ring.
9. Rotate the 7/16 hex clockwise to move the slack adjuster into the clevis (Do not pull/push rod out to meet clevis)
10. Install clevis pin and secure.
11. Insert the flat end of the anchor stud through the adjusting arm on the slack.

Mack Haldex Slack Adjuster Hitting Shock

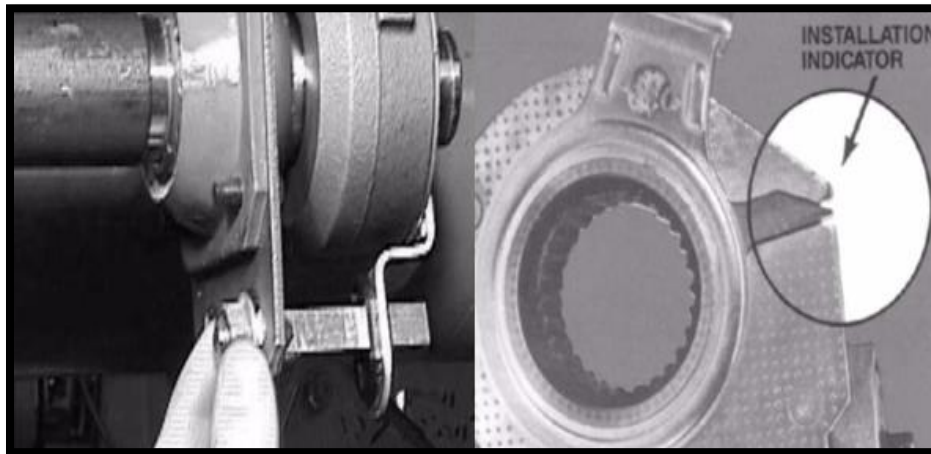

12. You must make sure the installation indicator is aligned with the notch.
13. Torque the anchor hardware to spec.

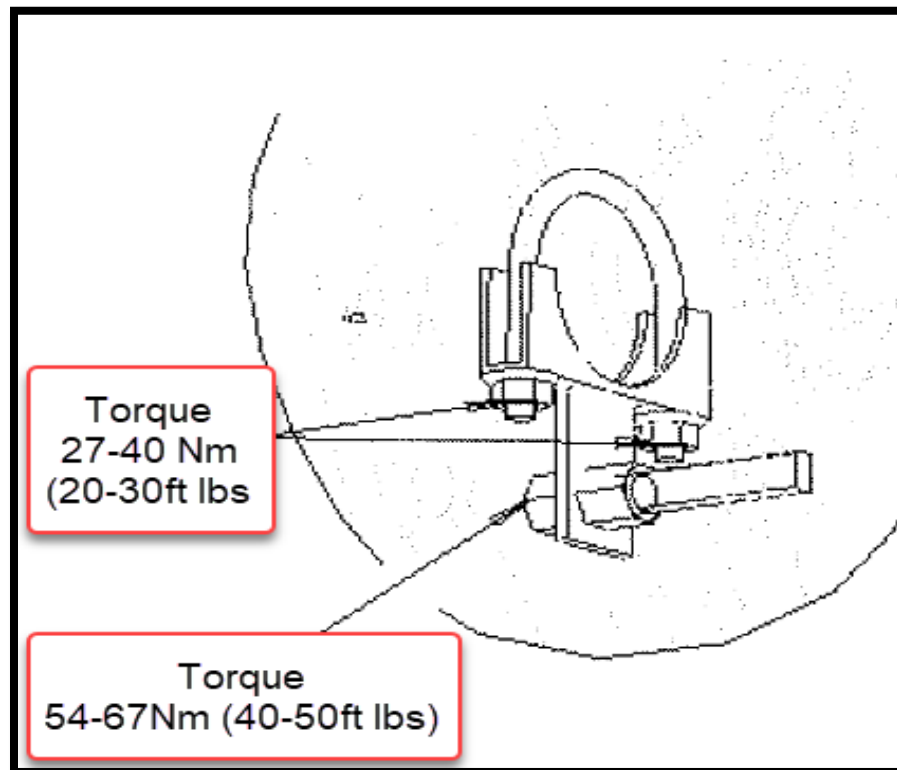

Mack Haldex Slack Adjuster Hitting Shock

14. Adjust the brakes by rotating the 7/16" adjusting hex clockwise until the lining just contacts the drum.
15. Rotate adjustment hex counterclockwise 1/2 turn. A ratcheting sound will occur on backoff. This is normal.

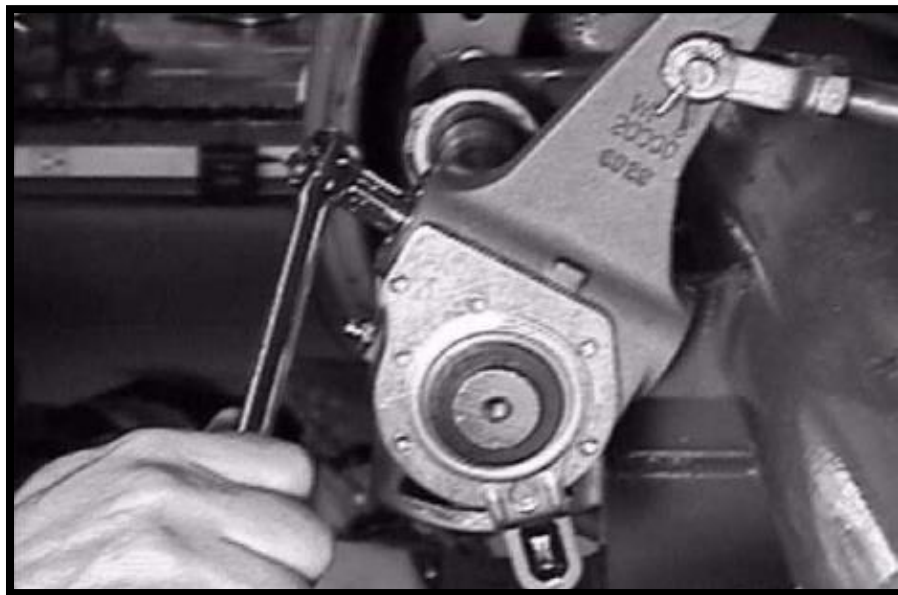

16. Repeat the same procedure steps for the slack on the other side.
17. Un-cage brake chambers.
18. Remove chocks from wheels.