



<b>Countries:</b>	AUSTRALIA, BAHAMAS, BOLIVIA, BELIZE, CANADA, CHILE, TAIWAN, COLOMBIA, COSTA RICA, DOMINICAN REPUBLIC, ECUADOR, EL SALVADOR, TRINIDAD AND TOBAGO, UNITED STATES, URUGUAY, VENEZUELA, MEXICO, ARUBA, NICARAGUA, PERU, PUERTO RICO, Curaçao, GUAM, GUATEMALA, GUYANA, HAITI, HONDURAS, JAMAICA, KOREA, SOUTH KOREA, PANAMA	<b>Document ID:</b>	IK1600131
<b>Availability:</b>	ISIS, IsSIR	<b>Revision:</b>	13
<b>Major System:</b>	CAB / SLEEPER / HOOD	<b>Created:</b>	3/8/2011
<b>Current Language:</b>	English	<b>Last Modified:</b>	6/14/2022
<b>Other Languages:</b>	NONE	<b>Author:</b>	Steven Bautz
<b>Viewed:</b>	6002		

[Less Info](#)

Hide Details

Coding Information

<b>Copy Link</b> 	<b>Copy Relative Link</b> 	<b>Bookmark</b>  <a href="#">View My Bookmarks</a>	<b>Add to Favorites</b> 	<b>Print</b> 	<b>Provide Feedback</b> 	<b>Helpful</b>  164	<b>Not Helpful</b>  123
----------------------	-------------------------------	--	-----------------------------	------------------	-----------------------------	---------------------------	-------------------------------

**Title: Cab Water Leak Troubleshooting Tips**

**Applies To:** LT, RH, ProStar, HX Steel Cab, and Lonestar sleeper cabs. However some aspects may also apply to all cabs in the High Performance Vehicle family - MV, HV, LT, RH, ProStar, LoneStar, TransStar, WorkStar(HV), DuraStar(MV), HX- (Steel cab) and TerraStar. Does not apply to: 9000i, PayStar(HX) Aluminum Cab, CityStar, CV, or LoadStar.

## CHANGE LOG

Please refer to the change log text box below for recent changes to this article:

06/13/2022 - Added note about the 10MM hole requirements for the roof marker light repair.  
04/19/2022 - Added Torque requirement for the roof marker light screws.  
03/23/2022 - Updated Marker Light repair info & detail to include new flat u-nuts.  
07/19/2021 - Updating recommended seam Sealer to replace 2611726C1-Bostik SuperTrans that has been discontinued.  
04/01/2019 - Update Info Concerning New Cab Door Vapor Barrier Seals - Ref to IK1600251 and Plastic Plug may be missing in BOC wall.  
04/20/2018 - Author updated for feedback purposes.02/06/2018 - Added Reference to LT, RH, MV, HV, and HX. Added Roof Marker Light Leak/Fix Issue.

**This document has been updated to include a repair procedure, please read this before proceeding with any of the troubleshooting techniques.**

If a cab has a known leak, it is not necessary to go through all the troubleshooting steps below. Skip straight to the resolution portion of this document and perform all the listed repairs, as this is very likely to resolve the concern in a single repair with no need for interior trim removal or roof removal. The entire job can be done in 4 hours or less. If leaks are still identified after performing the repair, then the below symptoms and troubleshooting sections may be helpful in further diagnosing the issue.

## DESCRIPTION

This document is intended to highlight areas that have been known to be the source of water entering and/or appearing inside the cab in order to help focus troubleshooting activities. Areas in the past that have been identified as possible sources are:

1. Condensation from the use of auxiliary sleeper heaters that are not hooked up to draw fresh air during operation.
2. Sunshade mounting
3. Roof marker Lights
4. Door seam & seals (Also see IK1600251 for other door leaks issues like the internal vapor barrier)
5. Cab seam above the rear corner of the door
6. Roof seams
7. Roof/cab bond joint
8. Windshield seal

## AREAS OF CONCERN AND COMMON SYMPTOMS

In general, evidence of water above the roof/cab joint will be related to condensation or gaps in the roof seams and/or roof attachments (air deflector, satellite mounting, etc.). Evidence of water below the roof/cab joint can come from a number of different areas that should be systematically considered.

1. Condensation
  - o Presence of water is independent of the presence of external precipitation
    - It's usually present after the truck sits in cold conditions for a long period of time with a heater running and the heater is set to recirculation mode, or the heater has no access to outside (fresh) air. For example: sleeper-only heaters.
    - Water may not show up immediately, but most likely after a short period of running on the road. Usually a reasonably hard maneuver (i.e. turns) will push the water to a location where it can drain from where it had collected in the roof substructure into the driver compartment.
  - o Water usually drips from the center overhead console (CB cubby area).
  - o Water can also drip out over the driver or passenger side doors (radio speaker area).
  - o If conditions are extreme or if condensation is excessive, water can collect on any or all interior roof trim panels.
2. Sunshade mounting
  - o Water typically presents itself during or shortly after driving through inclement weather or when subjected to a truck wash.
  - o Water usually drips from the center overhead console (CB cubby area).

- Water leaks from the sunshade mounting can originate where the bracket mounts to the cab or where the sunshade mounts to the mounting bracket. One or both areas may not be properly sealed.
3. Roof marker lights
- Each marker light is held in place with two #8 SS sheet metal screws. Depending on the date of manufacture; one goes directly into the cab roof and the other goes into a U-nut clip. Sometimes the U-nut tears the foam gasket. Sometimes the screw that goes directly into the cab roof strips the hole and causes the gasket not to compress and seal. This design has had two updates. To resolve any marker light leak, replace/add two new flat U-nuts to each location.
  - Remove each marker light to inspect and verify seal integrity. (See attached photos for example of defective seal.)
  - Check all five marker lights as more than one could be leaking. The small hole without a U-nut should be drilled out to approximately 10 mm and a new flat U-nuts 4325645C1 added to achieve proper torque for sealing. A light coat of RTV sealant on the foam gasket can be used if needed. Be sure to coat the drilled hole to prevent rust and use the new flat U-nut P/N: 4325645C1 in all places.
  - The hole size needs to be 10mm in order for the U-nut to engage to the panel and have proper float in the hole for this application.
  - Torque the two screws for each marker light to 20 +/- 10 IN-LBS (2.3 +/- 1.15 NM). **DO NOT OVER TORQUE AS PLASTIC LENS WILL CRACK.**

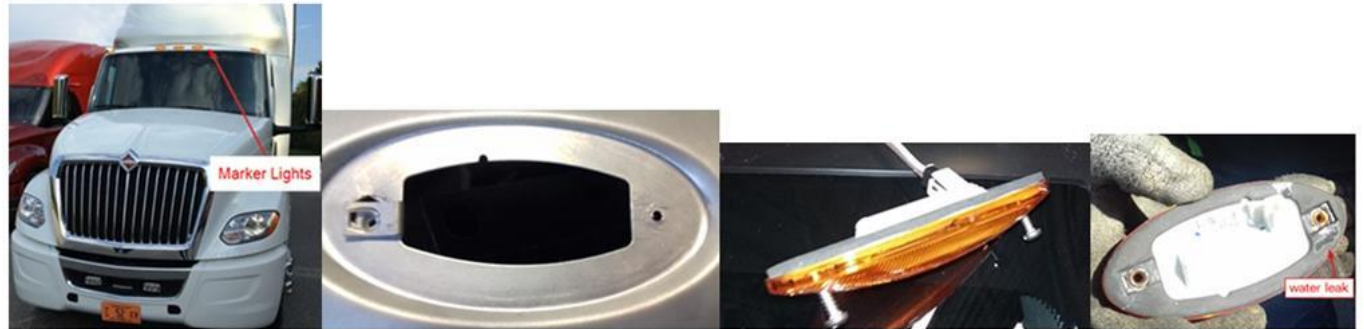

Be sure to remove and inspect all five marker light seals and be careful to not over torque the fasteners upon reinstallation.

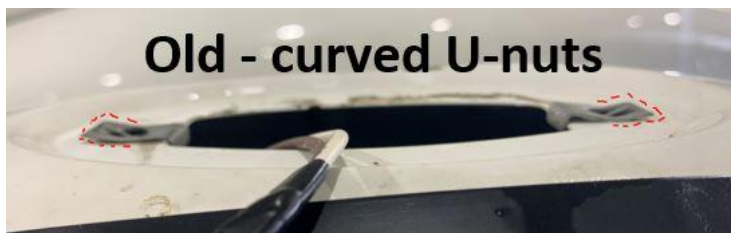

Images show the difference between the old and the new U-nut

4. Door seam & seals (Also see IK1600251 for other door leaks issues like the internal vapor barrier)
- Water typically presents itself during or shortly after driving through inclement weather or when subjected to a truck wash.
  - Water drips from above the driver or passenger side door.
  - Water drips from the top of the windshield on the outboard driver or passenger side (approximately below where the outboard sunshade mounting points are located).

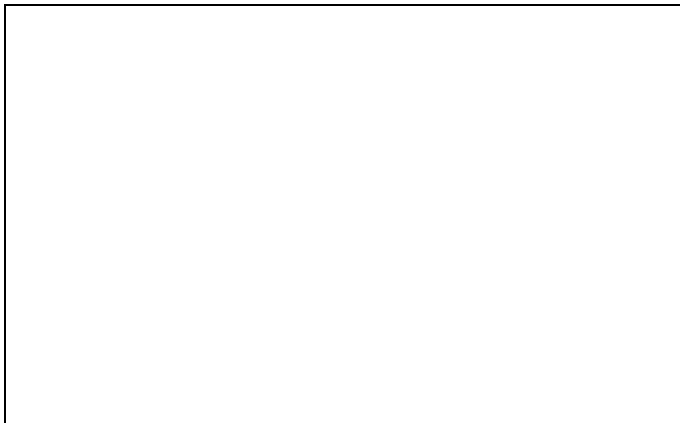

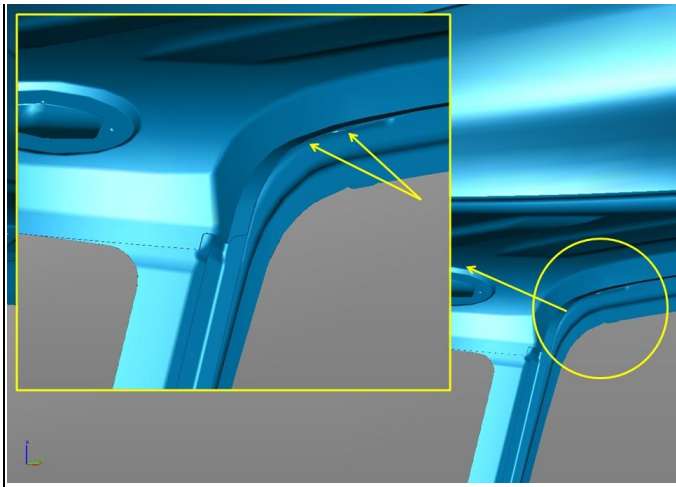

Although this seam is covered by the door seal, water can work its way under the seal and through this seam if this seam is not sealed properly at the factory.

5. Cab seam above the rear corner of the door

- o Water typically presents itself during or shortly after driving through inclement weather or when subjected to a truck wash.
- o Water drips from above the driver or passenger side door.
- o Water drips from the top of the windshield on the outboard driver or passenger side (approximately below where the outboard sunshade mounting points are located).

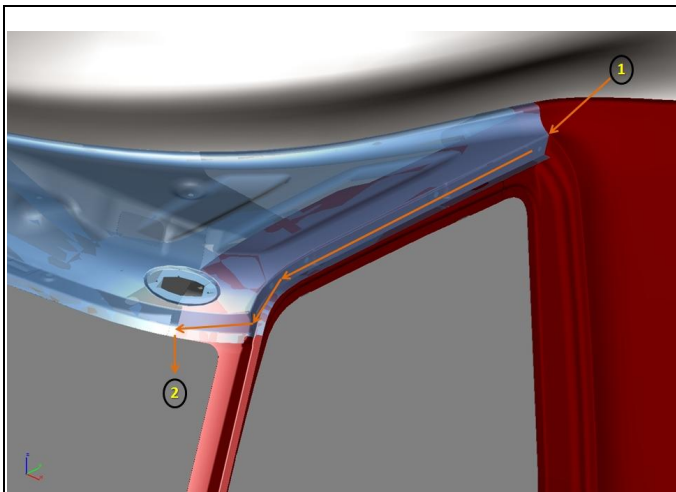

1. Water enters here.

2. Water exits here and drips down the inside of the windshield.

6. Roof seams

- o Water typically presents itself during or shortly after driving through inclement weather or when subjected to a truck wash.
- o Location where the water drips can vary depending on where the gap is in the roof seam.
  - Due to the design of the roof structure, water is most likely to travel along internal seams and joints and collect in the forward portion of the roof structure.
  - The final exit point is most likely to be in the forward cabin (over the driver/passenger side doors or at the center overhead console/CB cubby area).
  - The following areas have been identified as possible areas of concern. This is intended for guidance but is not necessarily all inclusive. Skyrise is shown, but Highrise is a similar construction (although seam locations and joints will vary).

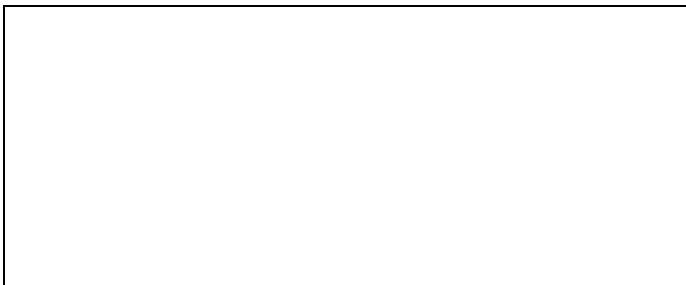

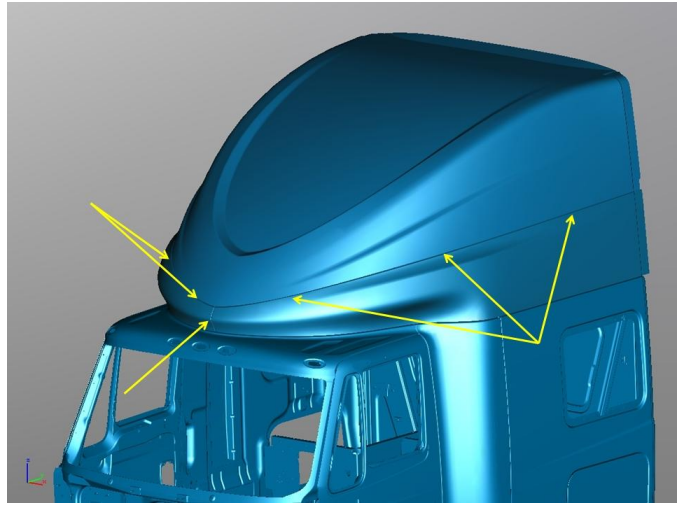

All roof seams should be checked for cracks or voids in the sealer.

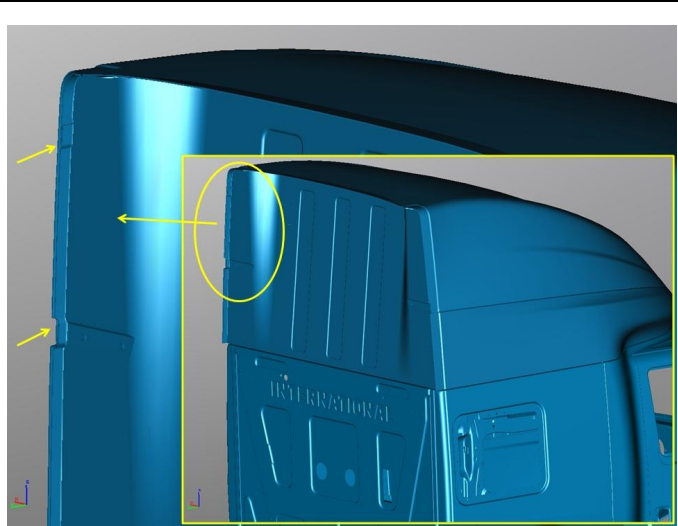

Seams at the rear corners of the Skyrise cab should be checked for voids.

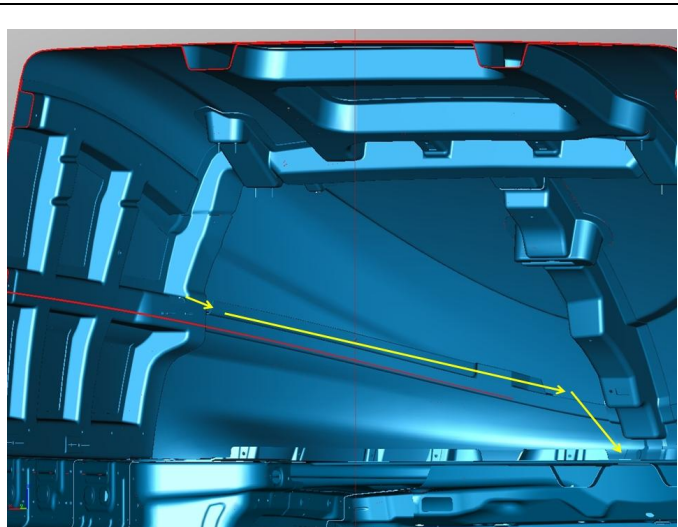

After penetrating the outer seams, water can travel along internal

reinforcement bond lines, ultimately draining into the trough formed by the lower roof panel and dumping near the front center of the driver compartment.

#### 7. Roof/cab bond joint

- Water typically presents itself during or shortly after driving through inclement weather or when subjected to a truck wash.
- Location where the water drips can vary depending on where the gap is in the roof/cab bond joint.
  - Gaps are more likely to be found above the driver/passenger side doors and rearward through the transition panel area.
  - Gaps in the front section of the roof can lead to water dripping from the center overhead console (CB cubby area).

**Note: Verify all plastic plugs are properly pressed/snapped into the holes in the back wall of the cab (See photo in troubleshooting section below)**

#### 8. Windshield seal

- Water typically presents itself during or shortly after driving through inclement weather or when subjected to a truck wash.
- Water drips around the edges of the windshield.

## **TROUBLESHOOTING**

Several methods can be used for troubleshooting water leaks. Regardless of the method, the troubleshooting process should be rigorous and disciplined. If a disorganized approach is used, the likelihood of not finding the leak point or not repairing all leak points on the same service call increase significantly. Use the above information to narrow down the areas to investigate further.

### Visual Inspection

- All exterior joints and seams should be visually inspected to determine possible problem areas.
- Look for any cracks or voids.
- Once suspect spots are identified, these areas should be further investigated using one of the following methods.

#### 1. Soapy water method

- Tape off major air escape points on the cab
  - Cab exhauster and door handles are must
  - Any other areas where air could escape and are known not to be contributing factors to the leak. For example, there is water dripping from the CB console; taping off the luggage compartment door will not affect that leak path and will when pressurizing the cab.
- Turn the HVAC to recirculation mode and set it to run on HIGH.
- Spray a soapy water solution on the suspect areas
- If bubbles form, there is a leak path in that location that should be addressed.

#### 2. Pressure washer method

- This method should be used if the soap and water method does not yield results.
- This method may require the removal of trim panels in the area where the suspect leak points are identified such that you can see if water is entering.
- Tape off all exterior joints, pressure wash all suspect areas, and inspect for leaks.
  - If no leak is found, remove a section of tape and repeat the process. Start with sections of tape in the areas that looked suspect on inspection. The goal is to methodically test all the suspect areas and identify which are actually contributing to the leak.
  - If a leak is found, note the area for future reference. Re-tape the bad section and continue the above process until all suspect areas have been tested and identified as being problematic or not.

## **RESOLUTION**

If there is a water leak in the upper portion of the cab, perform all the following repairs.

### Materials List:

Part Number	Description	Quantity
N/A	Isopropyl Alcohol	1 bottle
2611723C1	Dow® BETASEAL™ Glass Primer (20cc bottle)	1 bottle
3M: 760 UV*	3M® SMP Adhesive Sealant 760UV™ (10.5 oz. cartridge)	1 cartridge
2611722C1	Dow® Great Stuff™	1 can
3523427C2	Foam Seal	3
3820148C1	Bolt, M10-1.5 X 35MM HEX HD, TMS-4518	3
Blue 242**	Loctite® thread lock - OPTIONAL	1
2611725C1***	3/8" Foam Cord (50 feet)	1
2611724C1	Loctite® 5510 - Black	2

\* 2611726C1 - Bostik Super Trans has been discontinued and 3M 760UV (or equivalent) has been identified as a substitute.

\*\* Loctite should be used if 3820148C1 is not available and the original bolts are being reused.

\*\*\* 3/8" caulk backer rod/caulk saver cord can be used if 2611725C1 is not available. Caulk backer rod can be found at any home improvement store.

### **Sunshade Mounting Leaks**

1. Remove the marker lights to access the sunshade attachment bolts.
2. Disconnect the wire harness.
3. Remove the sunshade from the vehicle at the three mounting attachments and dispose of the fasteners (if the replacement fasteners, 3820148C1, are not available then keep the original fasteners for reassembly).
4. Remove and dispose of the foam gaskets on the mounts.
5. Thoroughly clean the fasteners that attach through the sunshade mounting brackets as well as the perimeter surface of each mounting bracket with IPA (isopropyl alcohol).

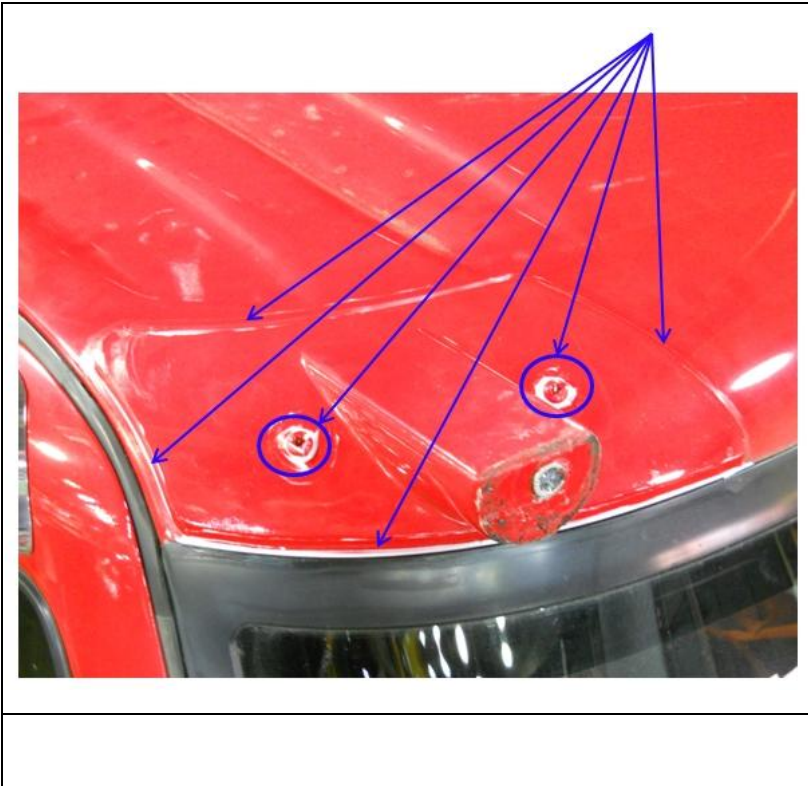

6. Allow the surfaces to dry.
7. Apply Dow® BETASEAL™ (2611723C1) to the same areas cleaned in Step 5.
8. Immediately wipe off the surfaces (prolonged exposure to the Dow® primer could damage the paint). These surfaces are now prepped for good adhesion to the sealer.
9. Apply 3M® SMP Adhesive Sealant 760UV™ on the fastener holes on each mounting bracket.
10. Apply 3M® SMP Adhesive Sealant 760UV™ all the way around the perimeter surface of each mount.
11. Allow sealants to thoroughly cure to a tack free condition before continuing.
12. Mask around the area of the center mounting bracket to protect the windshield and painted surfaces.
13. Spray Great Stuff™ (2611722C1) into the cavity of the center mounting bracket to seal the wire harness from water intrusion (spray into the wire harness pass through hole, see Arrow 1 in the figure for Step 14). The Great Stuff™ will expand and seal the cavity so only a partial can is needed.
14. Position the wire harness such that it remains centered in the pass through hole as the foam cures around it.

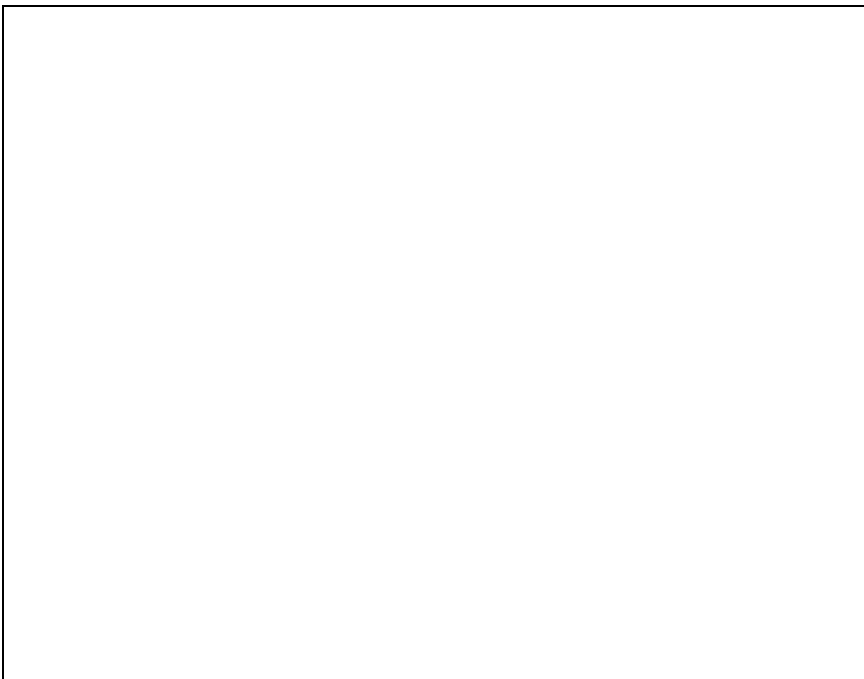

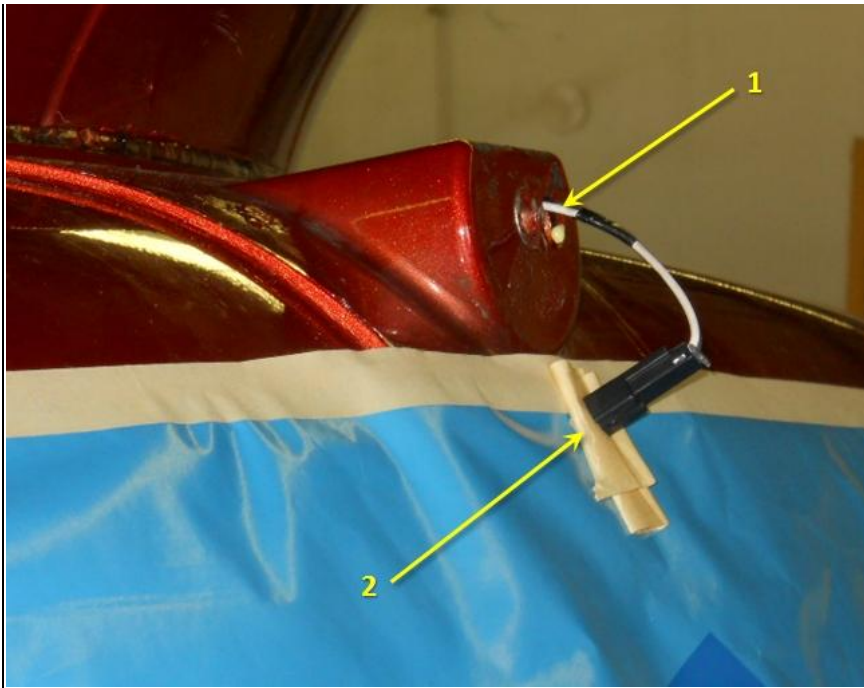

1. Keep the harness centered in this hole.
2. Masking tape works well for holding the harness in position while the foam cures.

15. Allow the foam to cure before continuing
16. Remove any excess Great Stuff™ as required prior to re-installing the sunshade.
17. Install foam seal part number 3523427C2 on each of the three mounting brackets.
18. Connect the wire harness of the sunshade to the wire harness seated in the mounting bracket.
19. Install the sunshade to each mount, fastening the sunshade with part number 3820148c1 into each hole at 15 ft-lbs (180 in-lbs) torque. If these parts are not available, the original fasteners can be used provided blue Loctite is applied to the threads prior to reinstalling.

**Door/Cab Seam Leaks** (Also see IK1600251 for door vapor barrier leaks)

1. Remove the secondary (outermost shed lip) seal from the door frame.

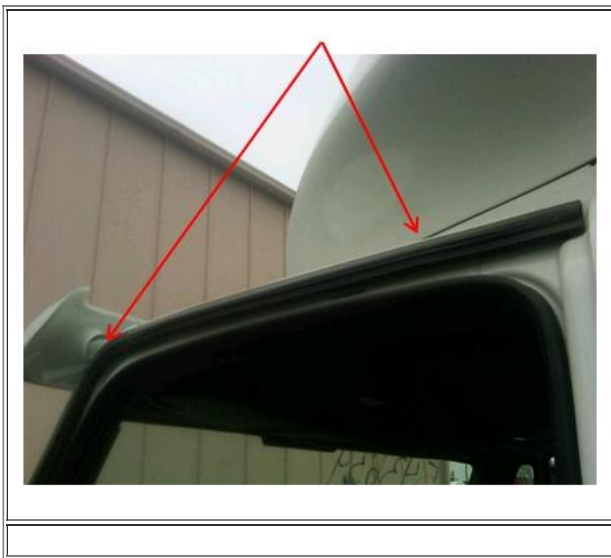

2. Use a brush to remove dirt and foreign material from the now exposed metal flange. This is especially important if there has been a prior seal/repair in this area.
3. Using IPA (isopropyl alcohol) clean the exposed sheet metal joint along the full length of the weld flange as well as adjoining sheet metal seams and any other suspect locations (visible voids/gaps) in the immediate area.



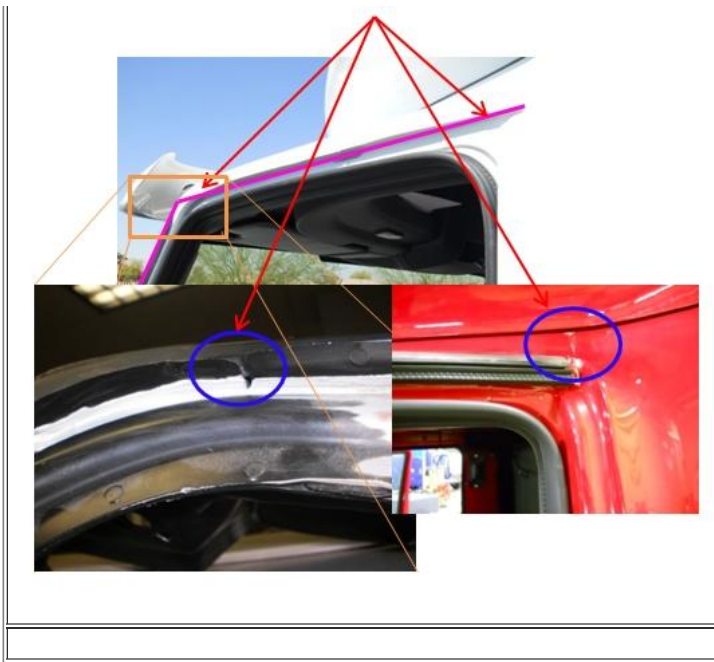

4. Allow the surfaces to dry.
5. Apply Dow® BETASEAL™ (2611723C1) to the same areas cleaned in Step 3.
6. Immediately wipe off the surfaces (prolonged exposure to the Dow® primer could damage the paint). These surfaces are now prepped for good adhesion to the sealer.
7. Apply 3M® SMP Adhesive Sealant 760UV™ to the prepped surfaces. Force material into the joint where possible. For best results, apply sealer into the seam wiping in both directions.
8. Allow material to dry until the adhesive is tack free.
9. Reinstall the secondary seal.

**Roof Seam Leaks (SkyRise only)**

1. Using IPA (isopropyl alcohol) clean the seams/joints and any other suspect locations (visible voids/gaps) in the immediate area. Look to be sure the black plastic plug is not missing. If plug is missing replace with service part plug. (P/N: 498376C1)

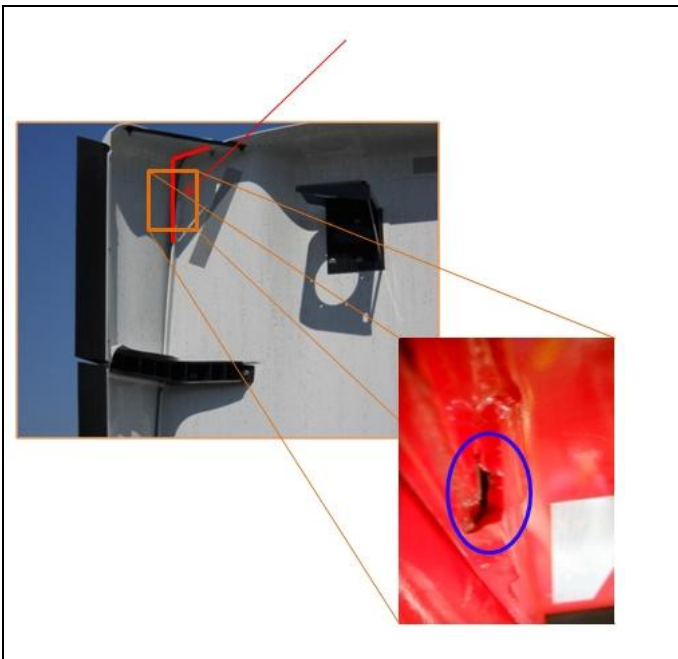

Top Photo - Driver side shown, passenger side symmetrically opposite.

This area is illustrated due to its obscurity as a water entry point. These instructions can be used on any roof seam that exhibits a void or inconsistency in sealer.

2. Allow the surfaces to dry.
3. Apply Dow® BETASEAL™ (2611723C1) to the same areas cleaned in Step 1.
4. Immediately wipe off the surfaces (prolonged exposure to the Dow® primer could damage the paint). These surfaces are now prepped for good adhesion to the sealer.

5. Apply 3M® SMP Adhesive Sealant 760UV™ to the prepped surfaces. Force material into the joint where possible. For best results, apply sealer into the seam wiping in both directions.
6. Allow material to dry.

**Note: When inspecting BOC on Sleepers - Look to be sure the black plastic plug is not missing. If plug is missing replace with service part plug. (P/N: 498376C1)**

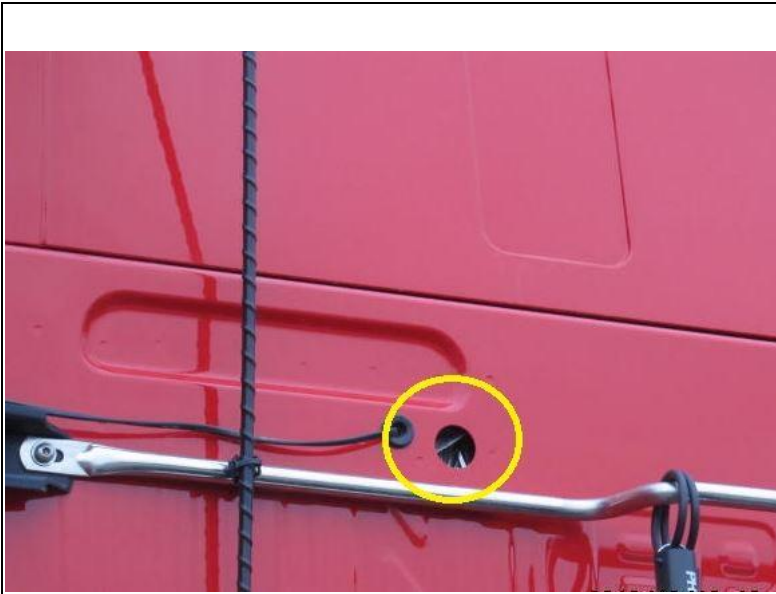

Example of missing plastic plug on BOC of most sleeper configurations. If this plug is missing; replace it with new one from service parts (p/n: 498376C1)

### **Roof Joint**

1. Clean the perimeter of the Roof to Cab Joint with IPA or Clean Paint Solvent. Clean as far up into the joint as feasible. This joint needs to be as clean as possible.
2. Insert 3/8" diameter foam cord (2611725C1) into the roof cab joint, starting at one of the rear corners before working your way around the cab. This will provide a backing for the sealer to be applied later.
3. To start, loosen the cab extender bolts and insert the start of the foam cord into the roof/cab joint on the forward side of the cab extender.
4. Push it through to the rear of the cab (behind the cab extender) so that there is 6-8" of foam cord rear of the cab extender. This can be pushed up into the rear corner to fill some space.
5. Insert the 3/8" diameter foam cord into the joint forward of the cab extender and continuously work around the perimeter of the cab.
6. Repeat the steps above at the opposite rear corner.
7. Insert the 3/8" diameter foam cord into the roof/cab joint along the entire length of the back panel.
8. Mask the entire perimeter of the joint between the roof and the cab to get the best possible appearance of the sealer and protect the surface from getting unwanted material on the painted surface of the cab or roof.
9. Apply Loctite® 5510 – Black (2611724C1) into the joint generously and continuously around the perimeter of the cab.
10. Use your finger or a tool to finish the joint to a smooth finish.
11. Remove the masking tape and allow the material to dry for 6-8 hrs before releasing the vehicle for service. Do not wait for the sealer to cure prior to removing the masking tape, as it could make removal of the tape more difficult.
12. Retighten the cab extender bolts.
13. Allow 24 hrs before washing with a high pressure wand if ambient conditions are warmer than 60 degrees F. Otherwise allow 72 hours.

---

## **WARRANTY INFORMATION**

### **Warranty Claim Coding:**

Refer to the [Warranty Coding Manual](#) for Group and Noun Codes.

### **Standard Repair Time(s):**

Refer to the [SRT Manual](#) for Repair Times

---

## **OTHER RESOURCES**

[Master Service Information Site](#)

 [Hide Details](#)

[Feedback Information](#)

Viewed: 6001  
Helpful: 164  
Not Helpful: 123

No Feedback Found

