

TECHNICAL INSTRUCTIONS

LIMITED SERVICE CAMPAIGN 22TD02

FUEL INLET HOUSING

CERTAIN 2021 MODEL YEAR HIGHLANDER
CERTAIN 2021 MODEL YEAR HIGHLANDER HYBRID

The repair quality of covered vehicles is extremely important to Toyota. All dealership technicians performing this repair are required to successfully complete the most current version of the E-Learning course “Safety Recall and Service Campaign Essentials”. To ensure that all vehicles have the repair performed correctly; technicians performing this recall repair are required to currently have completed all of the following courses:

T623 – Electrical Circuit Diagnosis

It is the dealership’s responsibility to select technicians with the above certification level or greater to perform this recall repair. Carefully review your resources, the technician skill level, and ability before assigning technicians to this repair. It is important to consider technician days off and vacation schedules to ensure there are properly trained technicians available to perform this repair at all times.

I. OPERATION FLOW CHART

The flow chart is for reference only. **DO NOT** use it in place of the full technical instructions. Follow **ALL** steps as outlined in the full technical instructions to confirm the campaign is completed correctly.

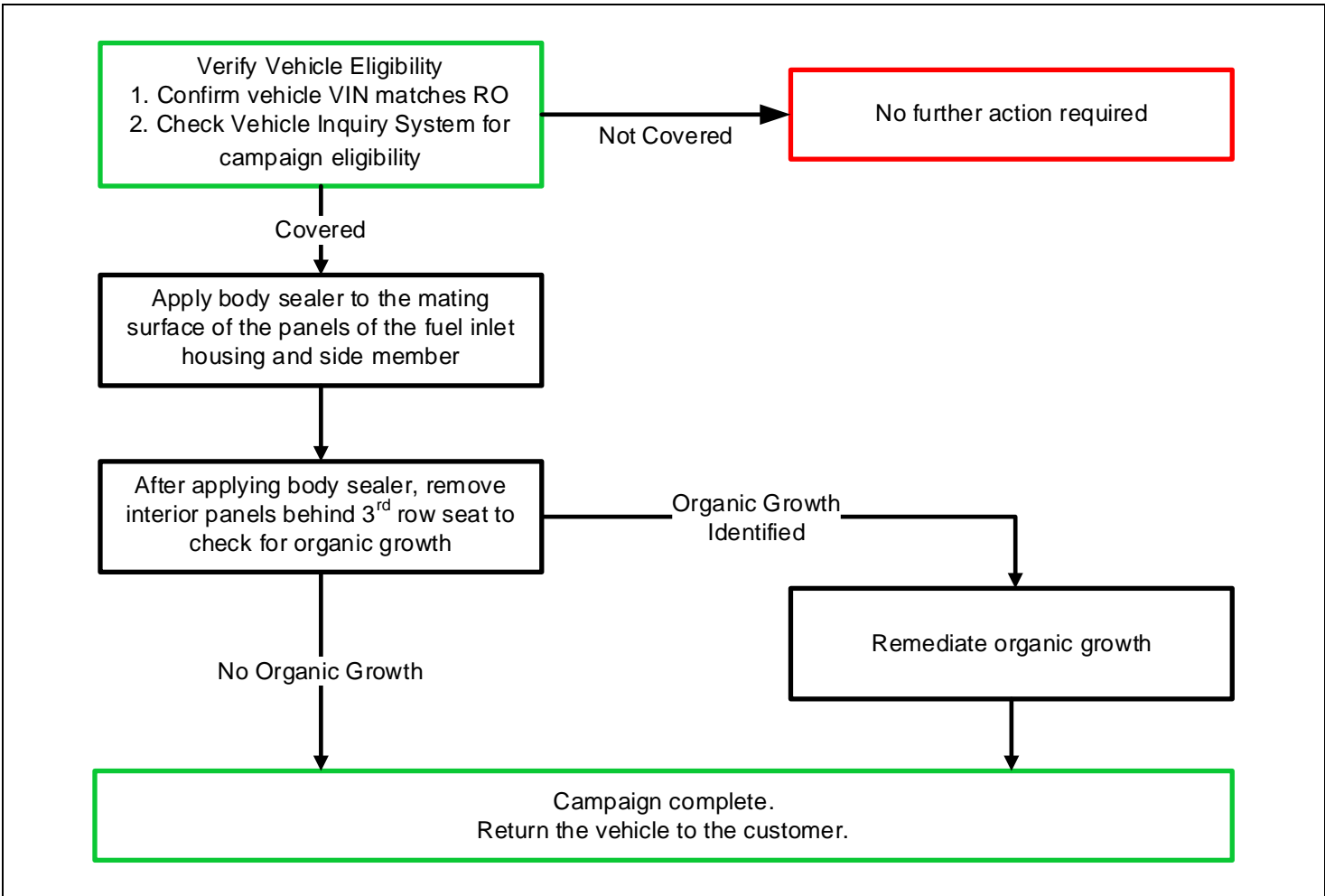

II. IDENTIFICATION OF AFFECTED VEHICLES

1. CHECK VEHICLE FOR CAMPAIGN ELIGIBILITY

- a) Compare the vehicles VIN to the VIN listed on the Repair Order to ensure they match.
- b) Check the TIS Vehicle Inquiry System to confirm the VIN is involved in this Campaign, and that it has not already been completed.

NOTICE:

TMNA warranty will not reimburse dealers for repairs completed on vehicles that are not affected or were previously completed, even by another dealer.

III. PREPARATION

A. PARTS

Part Description	Qty	Illustration	Remark
3M 08405 (Flexiclear body seam sealer)	1		Order from auto-parts store or online retailer.

B. MATERIALS AND SUPPLIES

- Mirror
- Protective Glasses
- Rubber Gloves
- Shop cloth/paper towels

IV. BACKGROUND

The involved vehicles are equipped with a fuel inlet housing which may allow water to leak into the interior of the vehicle through the seal between the fuel inlet housing and the vehicle body. If this occurs, customers may notice water in the interior area of the vehicle, behind the third-row seat.

V. SEALANT APPLICATION AREA DIAGRAM

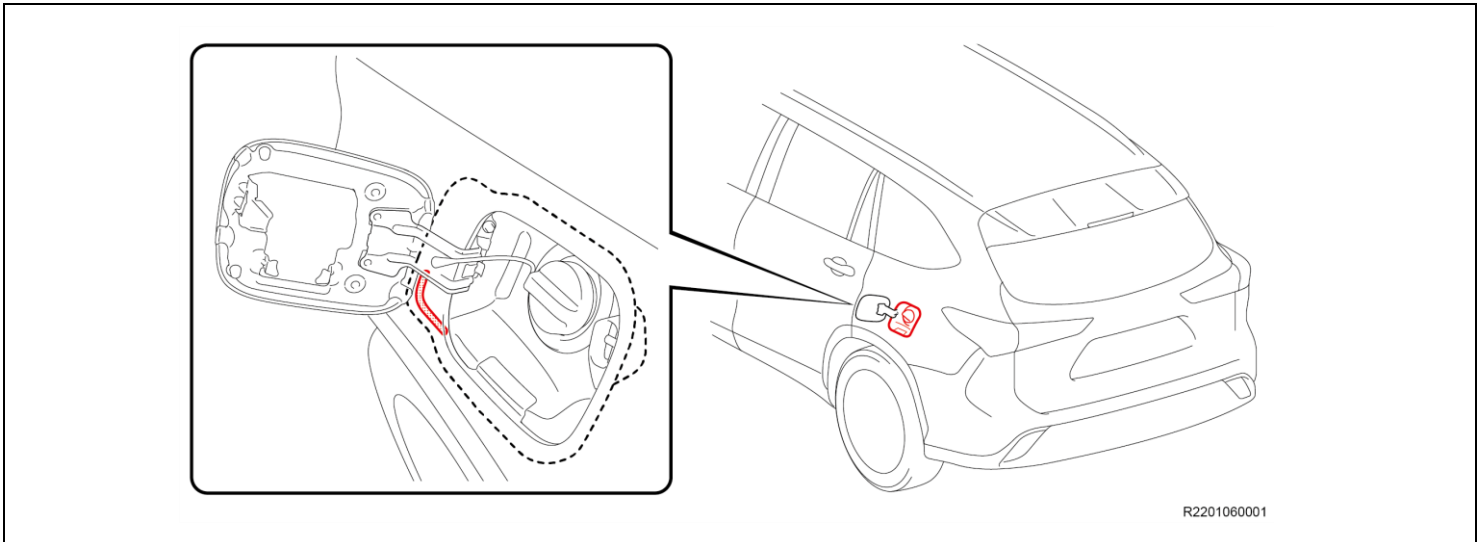

VI. APPLYING SEALER



BEFORE CUSTOMER ARRIVES AT THE DEALER

The vehicle needs to be dry when it arrives at your dealer to ensure proper sealer hardening.

- The customer should not bring the vehicle to your dealer if its presently raining, or if rain is forecasted to occur in the next 24 hours
- Reschedule the customer's appointment in the event of rainy weather
- The customer should not wash the vehicle (or otherwise get it wet) before bringing it to the dealer

BEFORE YOU RETURN VEHICLE TO CUSTOMER

The vehicle needs to remain dry for 24 hours after you return it to the customer to ensure proper sealer hardening.

After returning the vehicle, advise the customer not to drive the vehicle in the rain, wash the vehicle, or get the vehicle wet within 24 hours after the you return the vehicle.

NOTICE:

The quality of sealer application is ensured when operating temperature is 40°F - 100°F (4°C - 38°C). Confirm the work space meets this condition. If the condition is not met, the quality of sealer application will be affected.

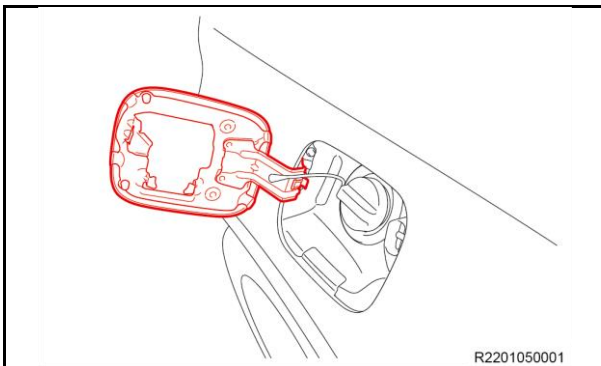

1. OPEN FUEL LID DOOR

2. LOCATE SEALER VOID USING A MIRROR

- c) Use a mirror to locate void in sealer on the bottom left corner of the fuel lid door opening.

NOTICE:

Sealer must be applied on the entire void area up to the existing sealer making sure there is no gaps in sealer.

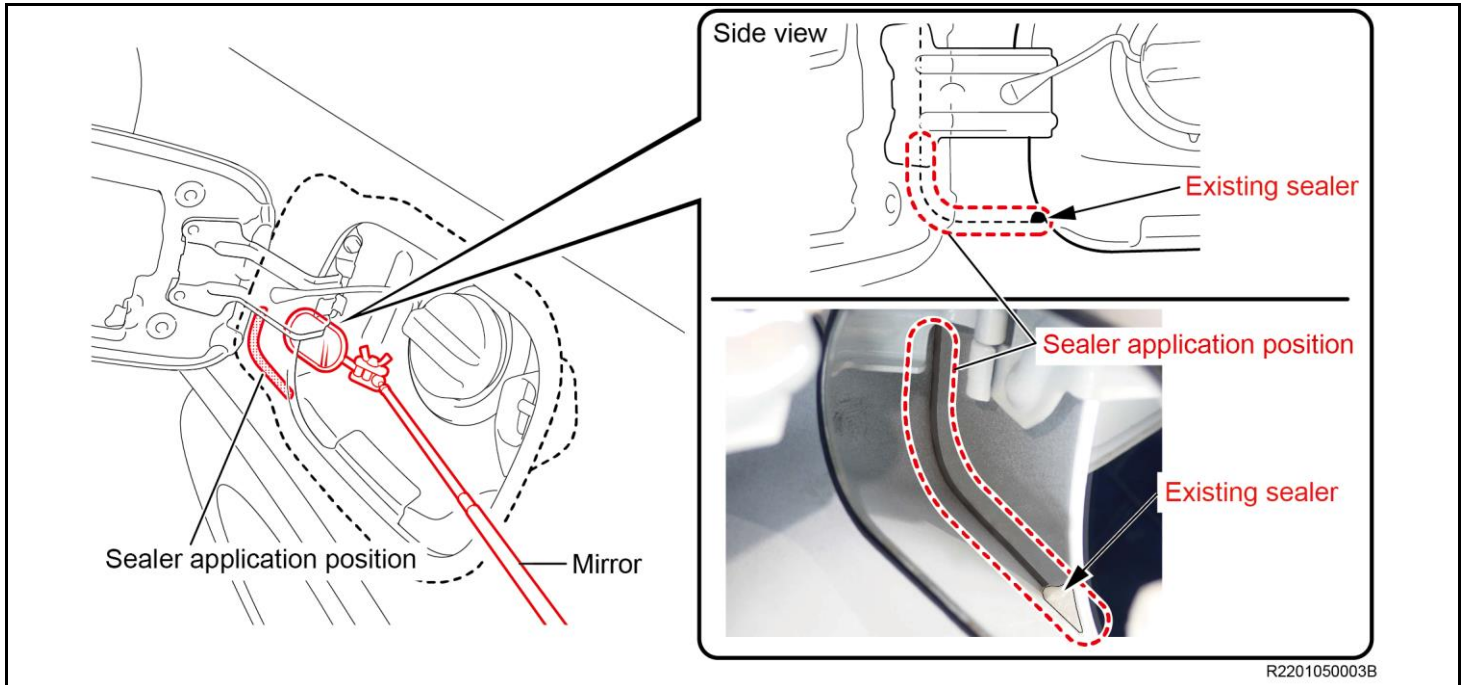

3. CLEAN AND DEGREASE THE SEALER APPLICATION POSITION

- a) Wear protective glasses.

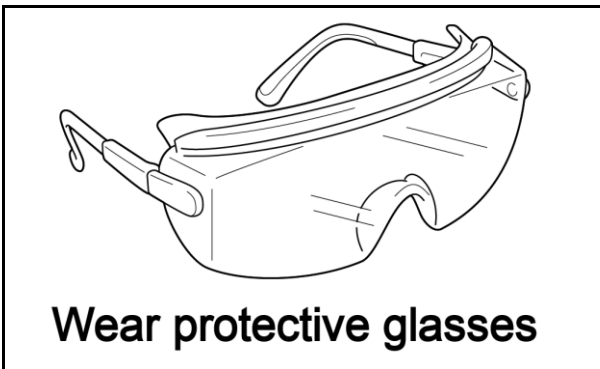

<SEALER APPLICATION POSITION CLEANING / DEGREASING STEPS>

- a) Wear protective glasses
b) Compressed air (remove foreign matter / water)
c) Degrease
d) Compressed air again (remove foreign matter)

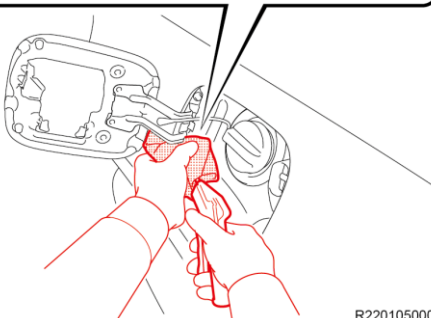

- b) Using compressed air, remove foreign matter and water from the sealer application area.

NOTICE:

Clean before applying sealant and make sure there is no foreign matter on the surface. Foreign matter may reduce quality of seal and cause water leak.

HINT:

Use shop cloths to keep foreign matter and water from scattering.

- c) Degrease the sealer application area.
d) Once again using compressed air, remove foreign matter and water from the sealer application area.

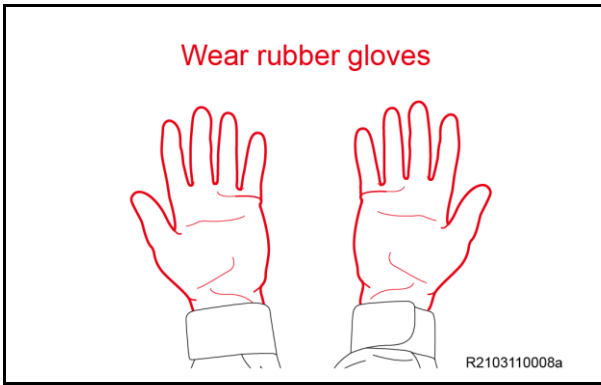

4. APPLYING SEALER

	<p>The sealer needs approximately 1 hour to solidify.</p> <p>DO NOT return the vehicle to the customer, move the vehicle, or let water contact the sealer until the sealer is dry (1 hour from application)</p>
--	---

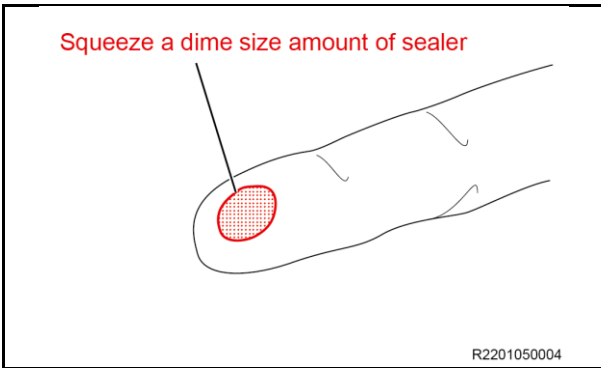

- a) Wear rubber gloves.
- b) Pick up sealer tube with and remove cap.
- c) Use left hand to squeeze a dime size amount of sealer onto right index finger.

- d) Apply sealer in several steps to the gap of the body panels from the fuel lid door hinge to the existing sealer.

NOTICE:

Be careful to only apply sealer in the voided area.

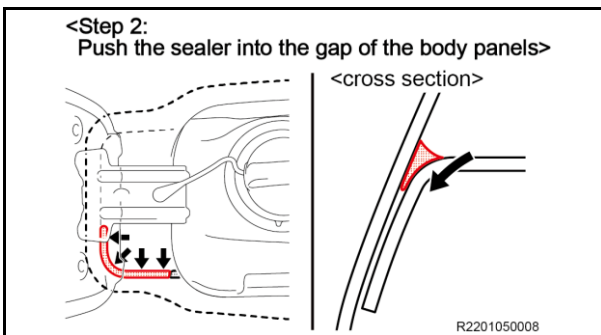
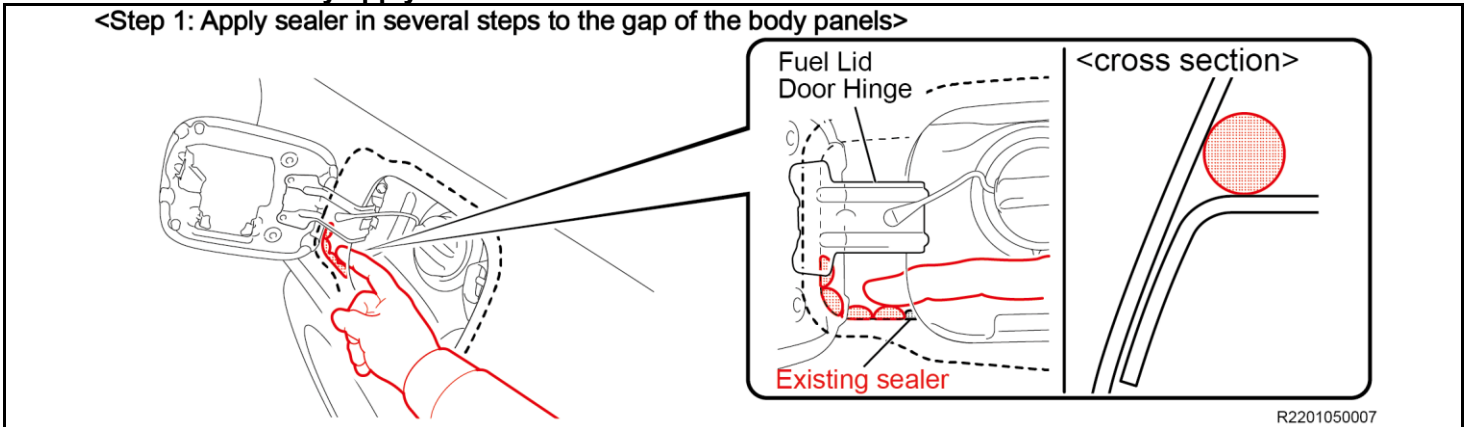

- e) Push the applied sealer into the gap of the body panels as shown in the illustration.

NOTICE:

Fill entire void with sealer, there should be no gaps in sealer.

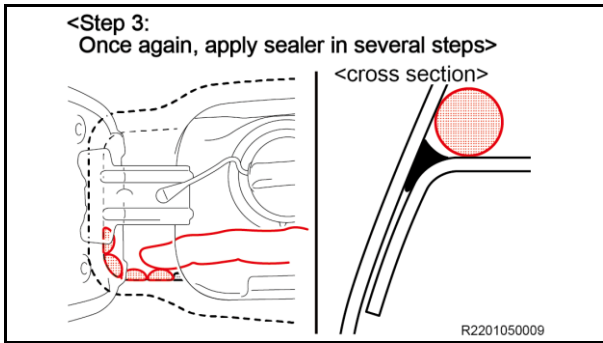

f) Once again, apply sealer in several steps onto the applied sealer as shown in the illustration.

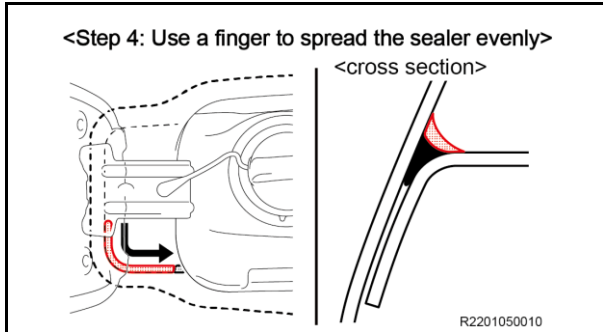

g) Use a finger to spread the sealer evenly as shown in the illustration.

NOTICE:

Be careful not to press down the sealer.

h) Use a mirror to confirm if void area is completely covered with sealer. Repeat steps until void is completely covered with sealer.

NOTICE:

- After application of sealant, no gaps should be present in sealant application area.
- Sealer must be applied on the entire void area up to the existing sealer making sure there is no gaps in sealer.

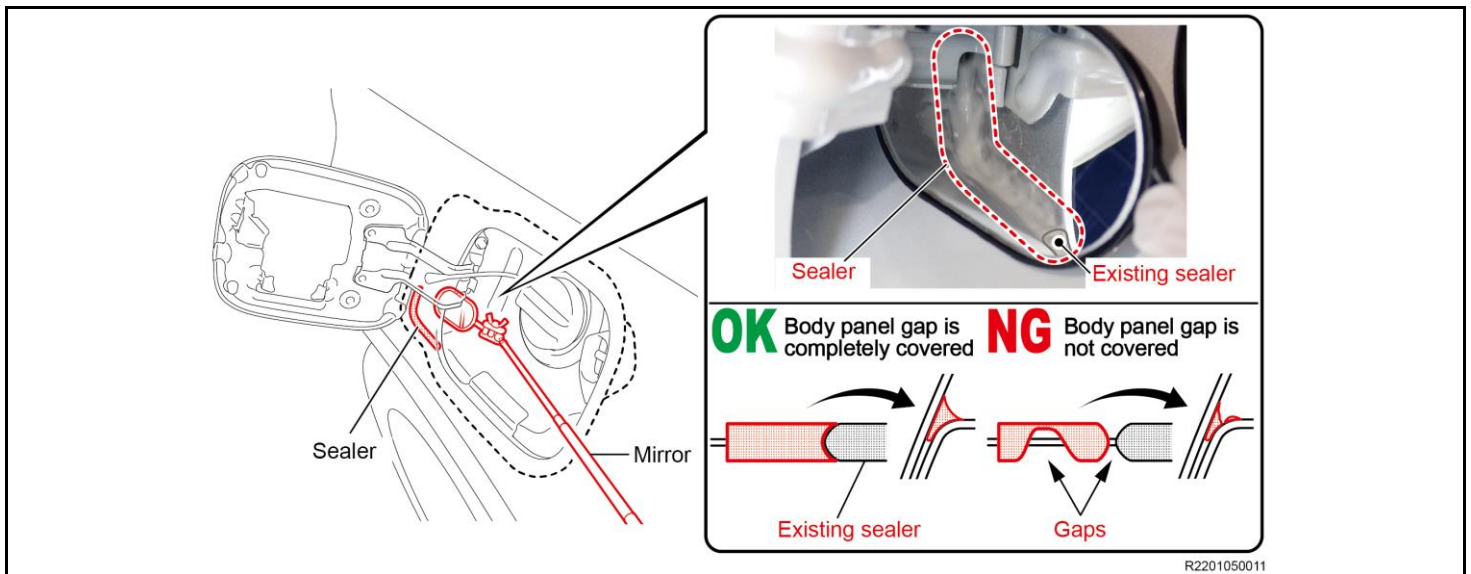

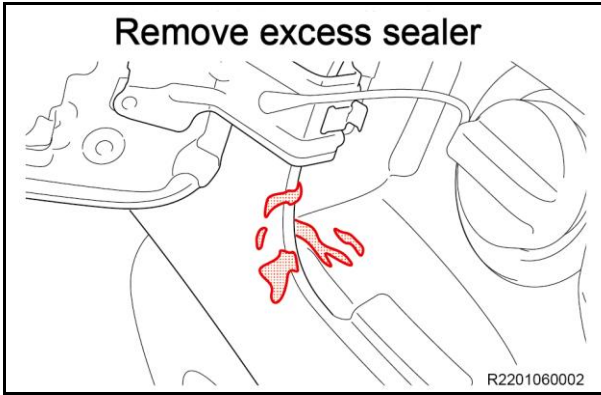

5. REMOVE EXCESS SEALER

- a) Remove any excess sealer in the visible area inside and surrounding the fuel door opening.
- b) Wait for the sealer to dry for about an hour.

After application of sealant, the sealant should not be visible without using a mirror. For instance, when filling the vehicle with fuel.



The sealer needs approximately 1 hour to solidify.

***DO NOT* return the vehicle to the customer, move the vehicle, or let water contact the sealer until the sealer is dry (1 hour from application)**

After returning the vehicle to the customer, inform them that the vehicle must remain dry for 24 hours. The customer should not drive the vehicle in the rain, wash the vehicle, get the vehicle wet etc.. within 24 hours after the remedy is performed

VII. ORGANIC GROWTH INSPECTION

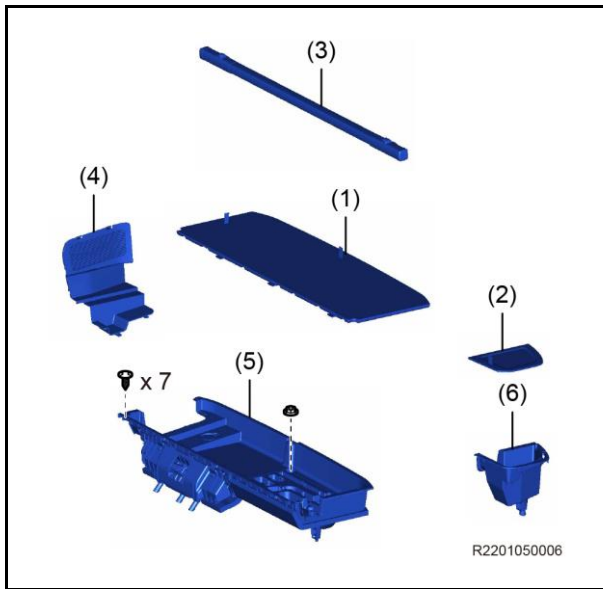

1. ORGANIC GROWTH INSPECTION

NOTICE:

You may inspect for organic growth while the sealer is drying.

- a) Remove the parts in the order shown below.
 - (1) DECK BOARD ASSEMBLY
 - (2) NO. 3 DECK BOARD SUB-ASSEMBLY (w/o Woofer)
 - (3) TONNEAU COVER ASSEMBLY (w/ Tonneau Cover)
 - (4) BATTERY SERVICE HOLE COVER
 - (5) REAR DECK FLOOR BOX
 - (6) DECK SIDE TRIM BOX LH (w/o Woofer)

b) Inspect the recessed area near the fuel filler inlet for the presence of organic growth

Organic Growth Inspection Area

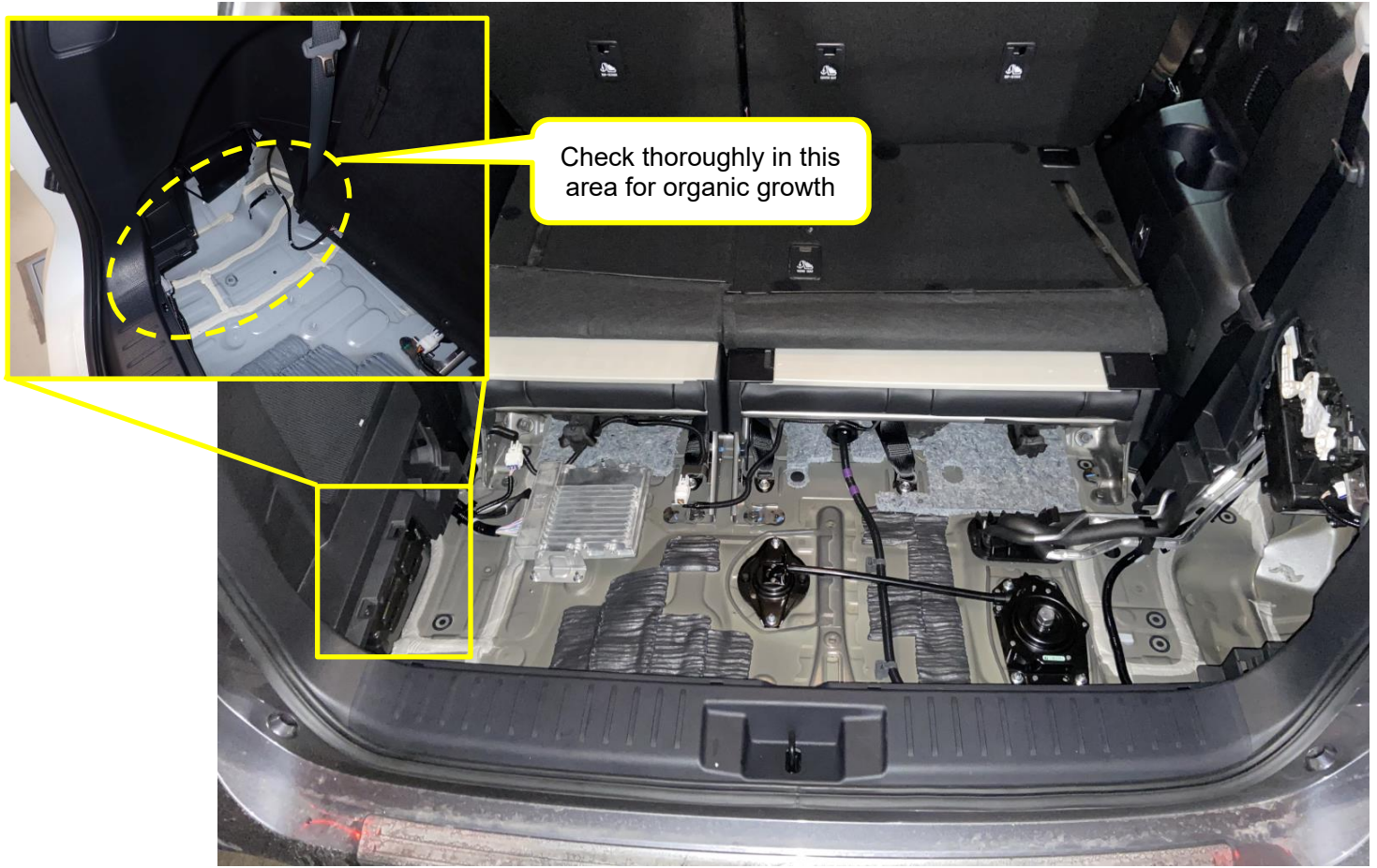





Examples of Organic growth

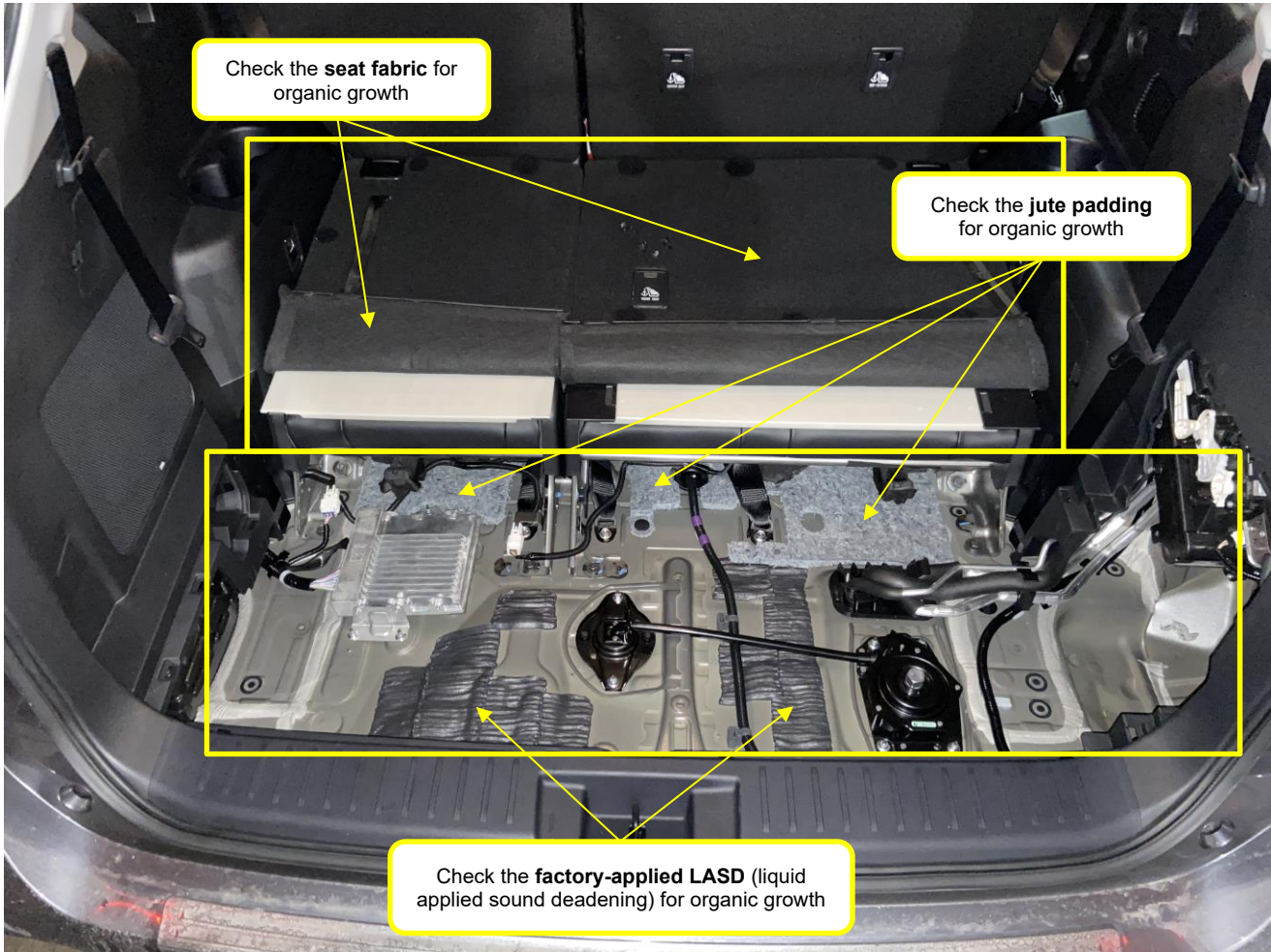

c) Inspect the remainder of the area for the presence of organic growth

Organic Growth Inspection Areas



Examples of Organic growth		
Fabric	Jute Padding	LASD
		

Result	Judgment	Action
OK	NO Organic Growth FOUND	Campaign completed, proceed to page 14
NG	Organic Growth FOUND	Remediate mold, follow instructions below

VIII. REMEDIATE ORGANIC GROWTH (If Necessary)

1. INITIATE ORGANIC GROWTH REMEDIATION PROCEDURES

Prepare the vehicle for organic growth remediation by following the instructions in [T-SB-0094-21](#). Start with the disassembly procedure on [Page 7 of 20](#). Key steps are shown below. Remember to follow the SERVPRO service request procedures in the T-SB.

- a. Disassembly procedure – guidelines for interior component removal
- b. Liquid Applied Sound Deadener (LASD) Removal Procedure
- c. Preparation for SERVPRO Remediation
- d. SERVPRO Remediation Service Request

2. POST REMEDIATION STEPS

- a. Application of Urethane Seam Sealer (If removed during LASD removal)
- b. Installation of Floor Silencer Sheeting in place of LASD. Replacement Silencer Sheeting part number details below.

Part Number	Description	Maximum Quantity
58651-22H91	Silencer Sheeting (3.0 mm thickness)	2
58651-22H92	Silencer Sheeting (1.5 mm thickness)	2

- c. Interior Reassembly Procedure A. Re-install vehicle interior, replacing organic growth damaged components as necessary.

IX. REASSEMBLE VEHICLE

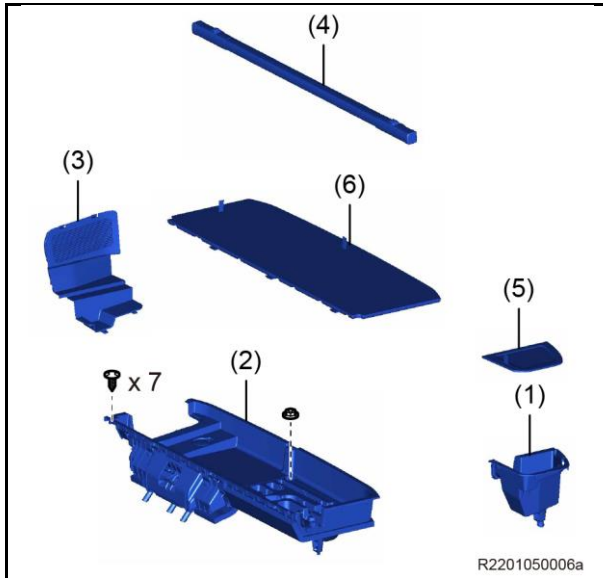

- a) Install the parts in the order shown below.
- (1) DECK SIDE TRIM BOX LH (w/o Woofer)
 - (2) REAR DECK FLOOR BOX
 - (3) BATTERY SERVICE HOLE COVER
 - (4) TONNEAU COVER ASSEMBLY (w/ Tonneau Cover)
 - (5) NO. 3 DECK BOARD SUB-ASSEMBLY (w/o Woofer)
 - (6) DECK BOARD ASSEMBLY

2. CLOSE FUEL LID DOOR



The sealer needs approximately 1 hour to solidify.

DO NOT return the vehicle to the customer, move the vehicle, or let water contact the sealer until the sealer is dry (1 hour from application).

◀ VERIFY REPAIR QUALITY ▶

- Confirm no DTCs
- Confirm all fasteners torqued to specification

X. APPENDIX

A. CAMPAIGN DESIGNATION DECODER

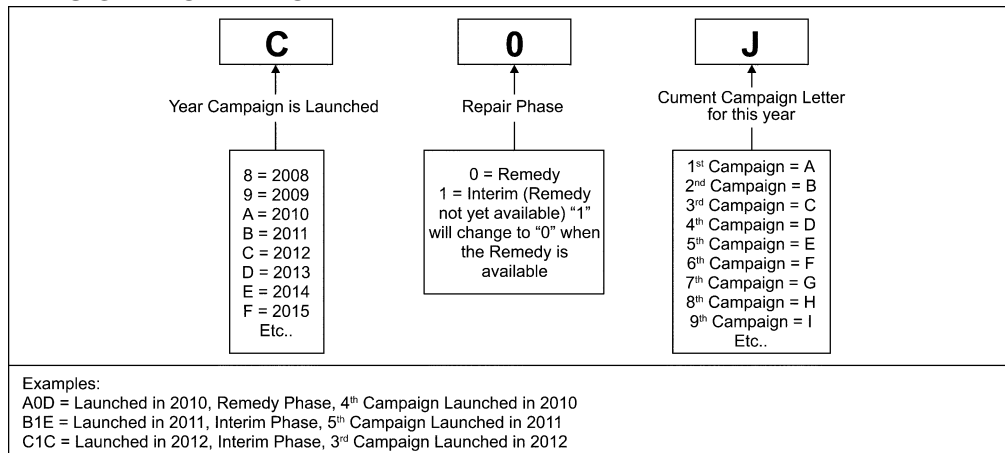

B. CAMPAIGN PARTS DISPOSAL

As required by Federal Regulations, please make sure all campaign parts (original parts) removed from the vehicle are disposed of in a manner in which they will not be reused, **unless requested for parts recovery return.**