



# Service Bulletin

Bulletin No.: 21-NA-192

Date: February, 2022

## TECHNICAL

**Subject:** Convertible Top May Not Lower Intermittently, DTC B19E4 SYM64 May be Stored in History

Brand:	Model:	Model Year:		Date Breakpoint:		Engine:	Transmission:
		from	to	from	to		
Chevrolet	Corvette	2020	2022	SOP	January 15, 2022	All	All

<b>Involved Region or Country</b>	North America, Middle East, Europe
<b>Condition</b>	Some customers may comment that the convertible top may not lower intermittently. Technicians may find DTC B19E4 SYM64 stored in history.
<b>Cause</b>	 <p style="text-align: right; font-size: small;">5892481</p> <p><b>Note:</b> This hall effect sensor (2) is looking for the roof to be fully latched at the header. We have seen cases where the hook is not extending far enough to reach the magnet (1). The cause of the condition may be that the hall effect sensor, in the right side folding top front latch striker, may be out of position.</p>
<b>Correction</b>	The simplest solution is to adjust the right side folding top front latch striker following the steps in the Service Procedure below.

## Service Procedure

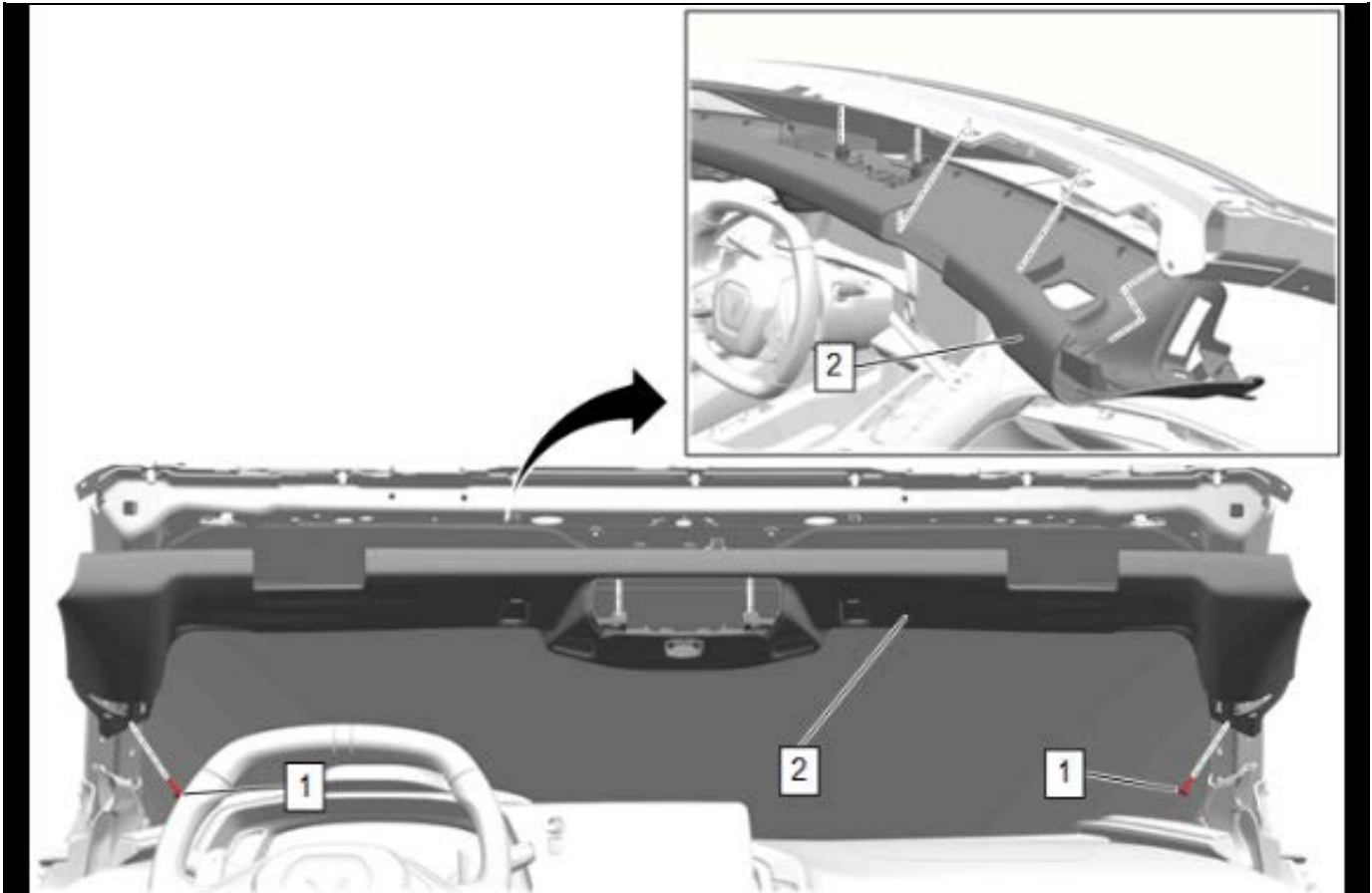

5389192

**Note:** The windshield upper garnish molding must be completely removed. Removing fasteners on only one side and flexing the molding, may damage the part. This type of damage due to not removing the complete molding should not be submitted under warranty.

1. Remove the windshield upper garnish molding (2). Refer to *Windshield Upper Garnish Molding Replacement (Convertible)* in SI.



5892482

2. Locate the right folding top front latch striker and mark the location of the outboard bolt washer.



5892483

3. Loosen the right folding top front latch striker bolts (1). Refer to *Folding Top Front Latch Striker* in SI.



5892484

4. After loosening the 2 bolts, move the striker outboard 2 mm (0.08 in), attempting to keep the same fore/aft positioning.



5892483

5. Tighten the folding top front latch striker bolts (1).  
**Tighten**  
Tighten the bolts to 22 N•m (16 lb ft).
6. Ensure the folding top functions correctly and the code does not return.

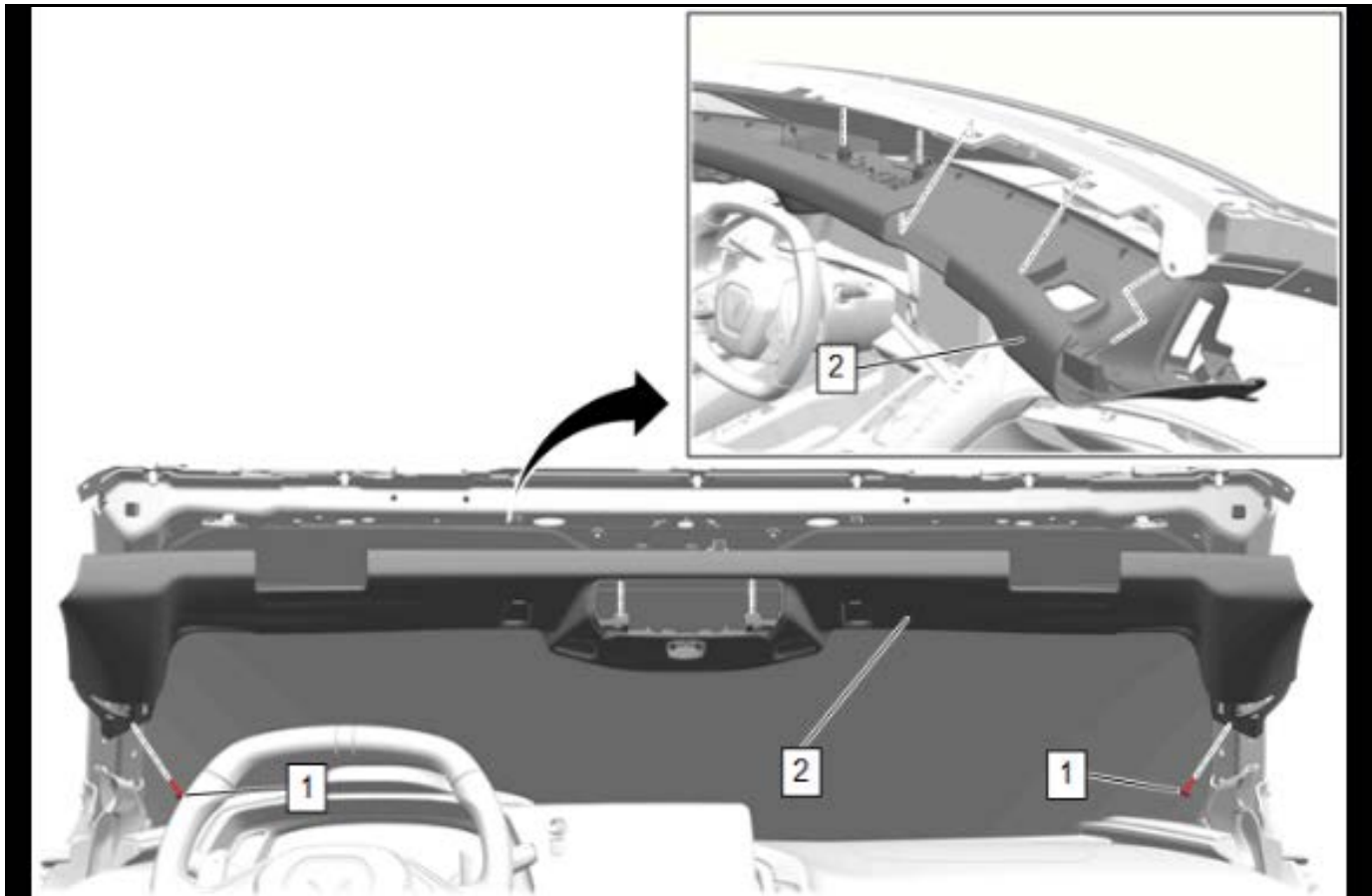

5389192

7. Reinstall the windshield upper garnish molding (2). Refer to *Windshield Upper Garnish Molding Replacement (Convertible)* in SI.

**Parts Information**

No parts are required for this repair.

**Warranty Information**

For vehicles repaired under the Bumper-to-Bumper coverage (Canada Base Warranty coverage), use the following labor operation. Reference the Applicable Warranties section of Investigate Vehicle History (IVH) for coverage information.

Labor Operation	Description	Labor Time
6086008*	Adjust the Folding Top Right Front Latch Striker	1.3 hrs
*This is a unique Labor Operation for bulletin use only.		

<b>Version</b>	2
<b>Modified</b>	Released August 23, 2021 February 18, 2022 – Added the 2022 Model Year, a Date Breakpoint and Europe to the Involved Region or Country section.

GM bulletins are intended for use by professional technicians, NOT a "do-it-yourselfer". They are written to inform these technicians of conditions that may occur on some vehicles, or to provide information that could assist in the proper service of a vehicle. Properly trained technicians have the equipment, tools, safety instructions, and know-how to do a job properly and safely. If a condition is described, DO NOT assume that the bulletin applies to your vehicle, or that your vehicle will have that condition. See your GM dealer for information on whether your vehicle may benefit from the information.



WE SUPPORT VOLUNTARY  
TECHNICIAN  
CERTIFICATION