



Mack Chassis - Data Link Diagnostics - Diagnostic Trouble Codes (DTC) / Fault Codes From Multiple Components - Unable To Connect To Chassis, Programming Failure With Premium Tech Tool (PTT) Errors - Troubleshooting And Oscilloscope Instructions



> Internal Content

Overview

Data link codes may cause multiple issues with a chassis, from programming failure to performance and Engine Aftertreatment System (EATS). If multiple modules or components are setting Diagnostic Trouble Codes (DTC) / Fault Codes for the Data Link, it may be necessary to use an Oscilloscope to locate the faulty component or isolate a shorted or broken harness.

Diagrams for each Data Link can be viewed [here](#).

Repair

Prior To Beginning In-depth Diagnostics

1. Check power supply
 - Ensure that batteries have proper voltage and pass load test
 - Make sure that all battery connections are clean and tight
 - Check that grounds are clean and tight
 - Check that any modules coding have good power and ground
2. Verify that there are no non-OEM modules that have been installed on the data link
 - Aftermarket-installed driver computers, GPS, data logs, tracking devices (etc) can interfere with communication between chassis and powertrain modules.

If Further Diagnostics Are Required

A. PTT should be utilized prior to proceeding with the below steps. Guided Diagnostics (GD) for Data Links can help to isolate the module or system causing the problem and should be a selectable option with data link codes logged as seen below

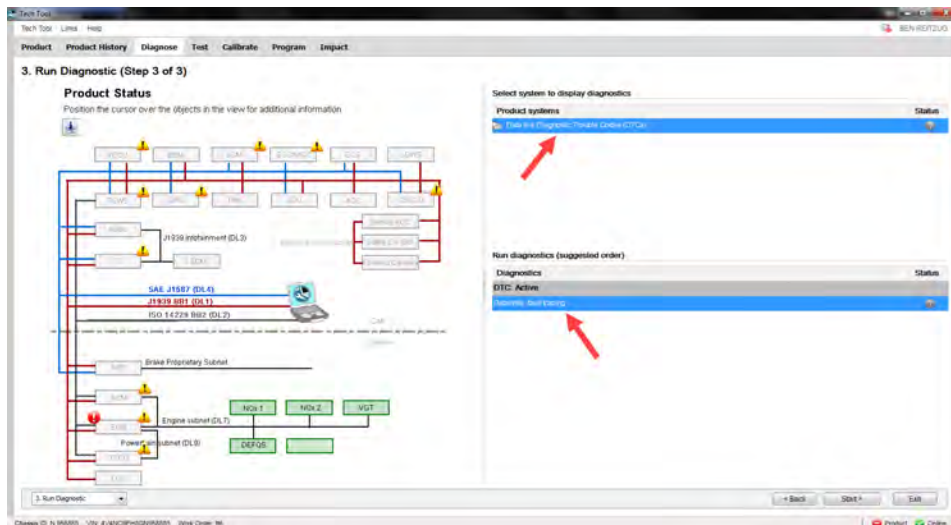

Note: Pre-OBD vehicles will have a different operation than the one shown above depending on the codes that are set. Diagnostic steps will be similar to those used for OBD chassis.

B. Begin by checking data link voltages and resistances. Diagnostic steps are outlined in Data Links, Fault Tracing (SB 371-49), which can be found in [IMPACT](#).

- Search by the article title, not bulletin number.
- Also listed under Function Group 371

C. If voltage and resistance are within spec, an Oscilloscope can be used to check signals on the J1939 data link(s) present in the chassis

- The 4-Channel Oscilloscope is the current tool used for diagnosis, part number 88890040, and is available through Parts



- If necessary, a 2-Channel Oscilloscope can be utilized as well. Part number for the 2-channel scope is 9998489. *This tool is no longer available from Parts and is included for reference only.*



Oscilloscope Procedure

1. Connect the Oscilloscope to the computer
2. Under the Test tab in PTT select the correct operation

- For Pre-OBD chassis (US10 emissions and older, 9-pin Diagnostic Connector), select operation 1700-21-03-04 Oscilloscope

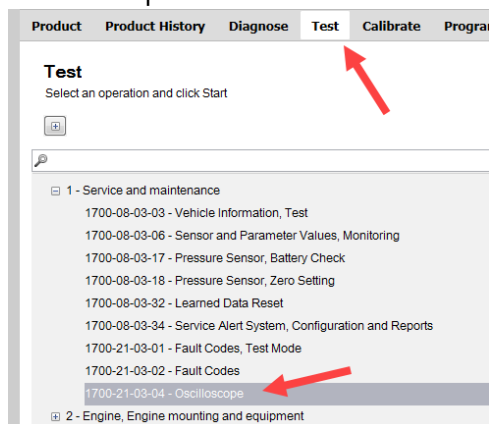

- For OBD chassis (US13 emissions and newer, 16-pin Diagnostic Connector), select operation 3711-08-03-03 Data Links, Fault Tracing With Oscilloscope

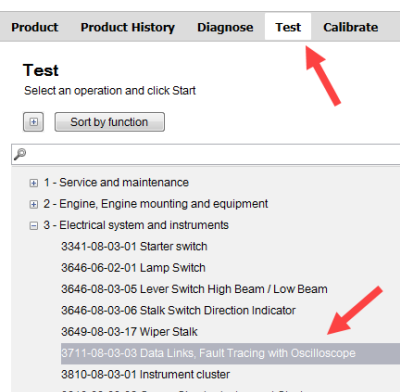

- 2a. Follow the steps in PTT to open the TiePie Multi Channel software

- For Pre-OBD chassis, pressing the Play button in the upper left-hand portion of the Test screen will open the Oscilloscope program

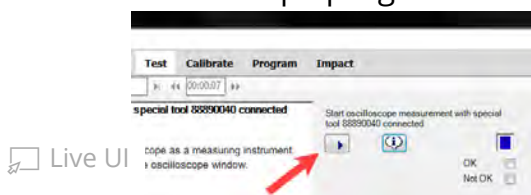

- For OBD chassis, PTT will provide a button to push that opens the Oscilloscope program following verification steps. Make sure the correct data link is selected

Action

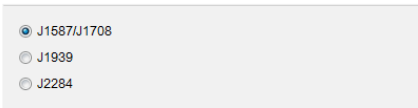

Press the button below to open the program



3. Once the program opens, ensure that the graph is properly configured.

- Refer to the screenshot below for the correct settings:



- Values can be set by right-clicking on the value to be changed:

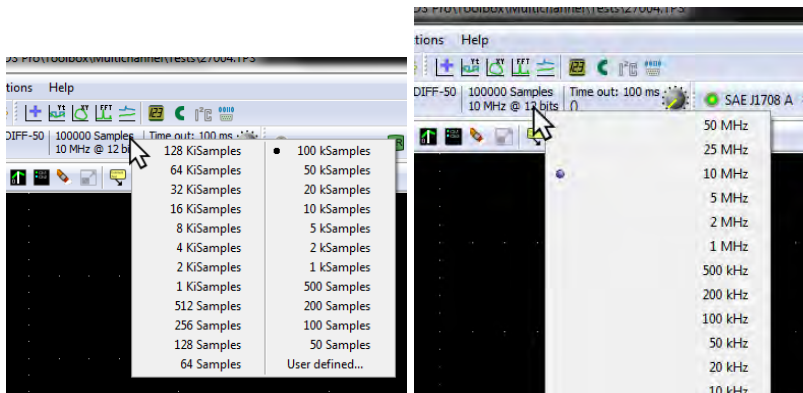

- Channels can be added to or removed from the graph by clicking on the channel number in the menu bar where graph scale is selected.
- Channels can be moved from one side of the window to the other by clicking and dragging on the colored tab at the top of the axis.

4. Connect the Oscilloscope probes to the correct pins for the high and low side of the data link to be metered

- Diagnostic connector information is included in the Data Link Fault Tracing document indicated in Step B.
- The 4-channel Oscilloscope can monitor two connections at once, which is useful for comparing signal at a component with that at a module.

5. With the probes connected to the correct pins, press the Play button in the upper left corner of the screen

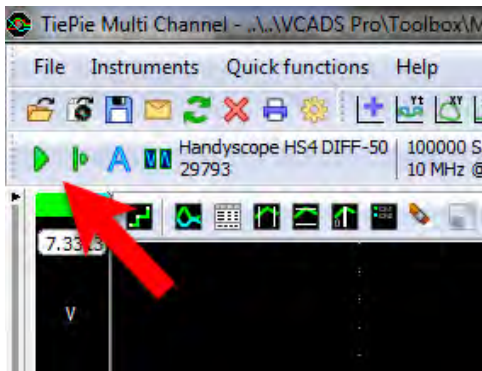

6. Review the J1939 Reference Signals below:

- Two channel:

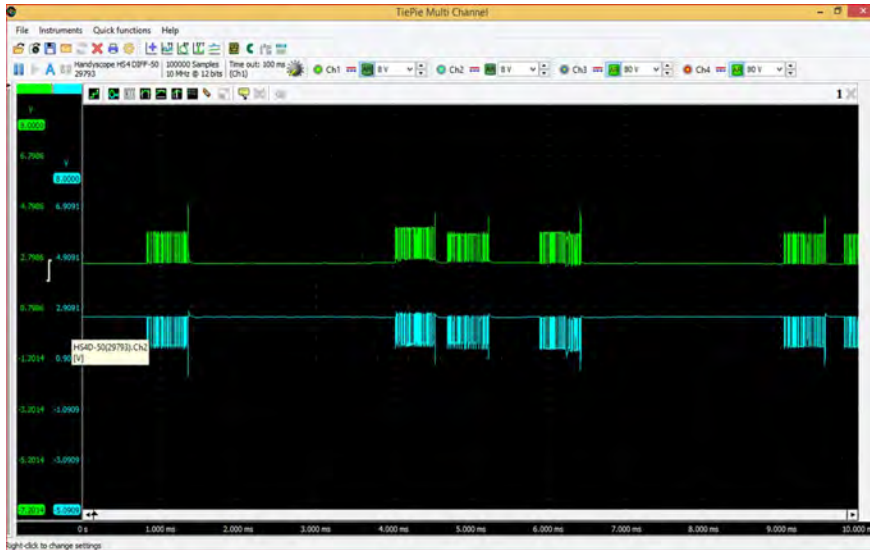

- Four channel:

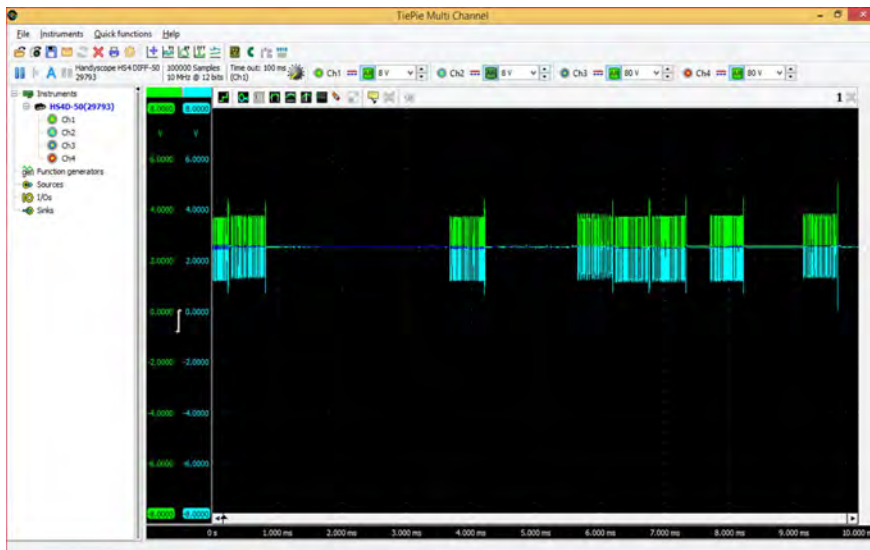

7. Compare the results of the reading from the chassis with the reference signals.

- Examples of common component checks can be reviewed in the PDF document attached [here](#).

 Tags

- [k00747793](#)
- [u02a3](#)
- [u3017](#)
- [fault tracing](#)
- [data link](#)
- [datalink](#)
- [datalink fault](#)
- [data link fault](#)
- [data link diagnostics](#)
- [u010c](#)
- [mack](#)

Related links and attachments

No links or attachments available

 **Feedback**

[Give feedback](#)

to help improve the content of this article

Battery Cable, Routing

V-371-049

(October 2014)

Valid for

VOLVO VN, VHD, and VAH trucks built between January 1, 2008 and June 29, 2014

Case description

On some trucks, the battery cables could cross each other behind the battery box and battery cut off switch. Chafing between the battery cables could eventually cause a rub through of the cable protective coating. The installation of a double headed cable tie (part number 21087716) and new cable routing will prevent chafing of the battery cables.

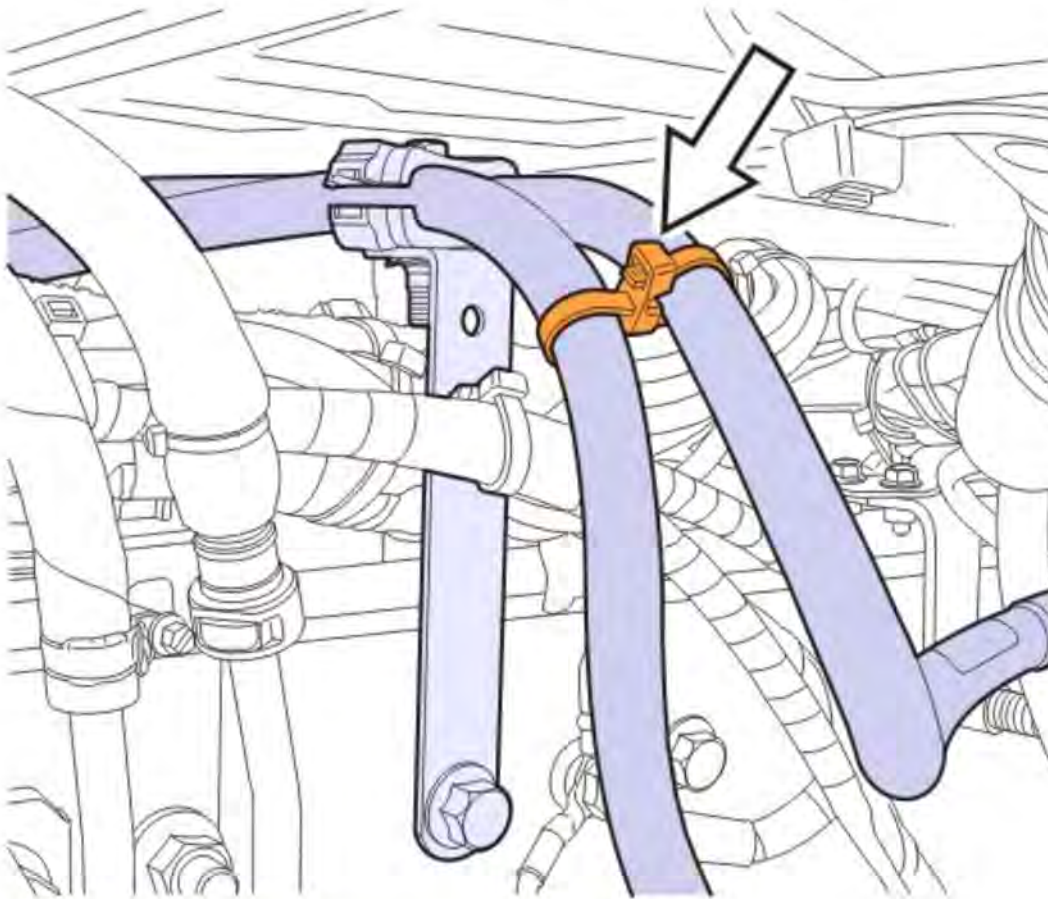

Required Parts (Battery Cable, Routing)

| Item | Description | Part Number | Qty |
|------|-------------------------|-------------|-----|
| 1 | Double Headed Cable Tie | 21087716 | 2 |

Decommissioning the Truck for Repair

Copyright to this documentation belongs to the Volvo Group. No reproduction, copying, change, amendment or other similar disposal is entitled without prior written consent by the Volvo Group

The information contained herein is current at the time of its original distribution, but is subject to change. The reader is advised that printed copies are uncontrolled.

You must read and understand the precautions and guidelines in Service Information, group 30, "General Safety Practices, Electrical" before performing this procedure. If you are not properly trained and certified in this procedure, ask your supervisor for training before you perform it.

NOTE: Information is subject to change without notice. Illustrations are used for reference only and can differ slightly from the actual vehicle being serviced. However, key components addressed in this information are represented as accurately as possible.

1. Park the vehicle on a flat and level surface.
2. Apply the parking brake.
3. Place the transmission in neutral or park.
4. Install the wheel chocks.

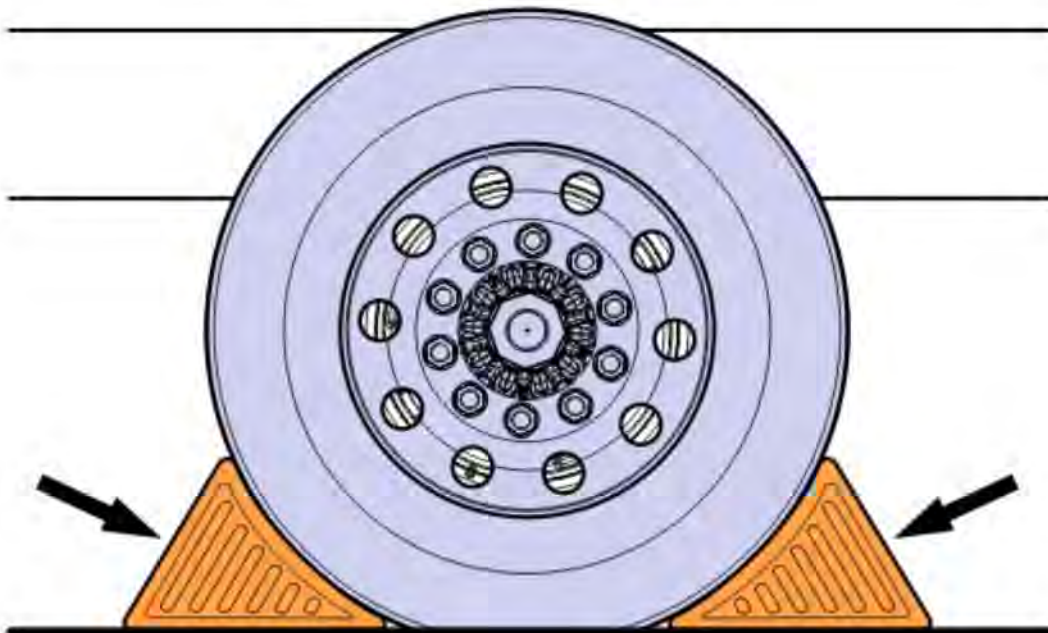

5. If applicable, remove the side fairing.

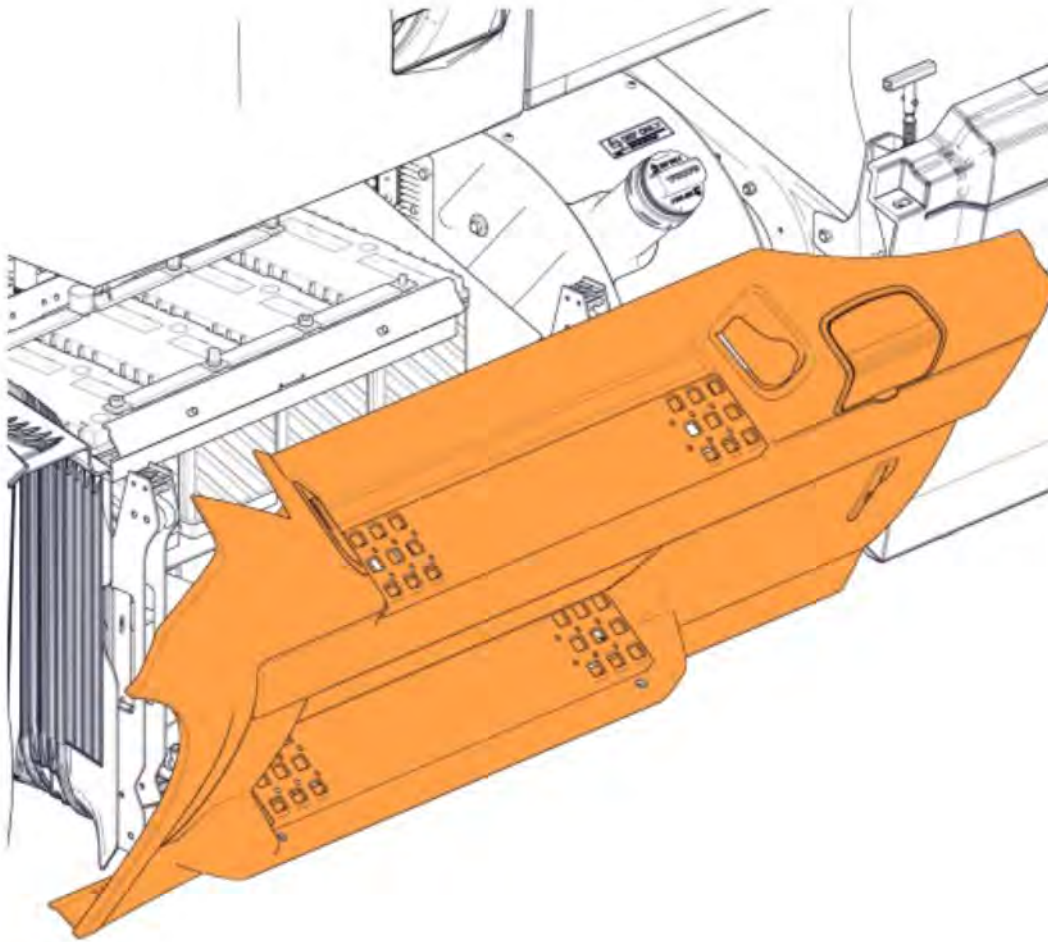

6. Disconnect the cable from the battery's negative terminal.

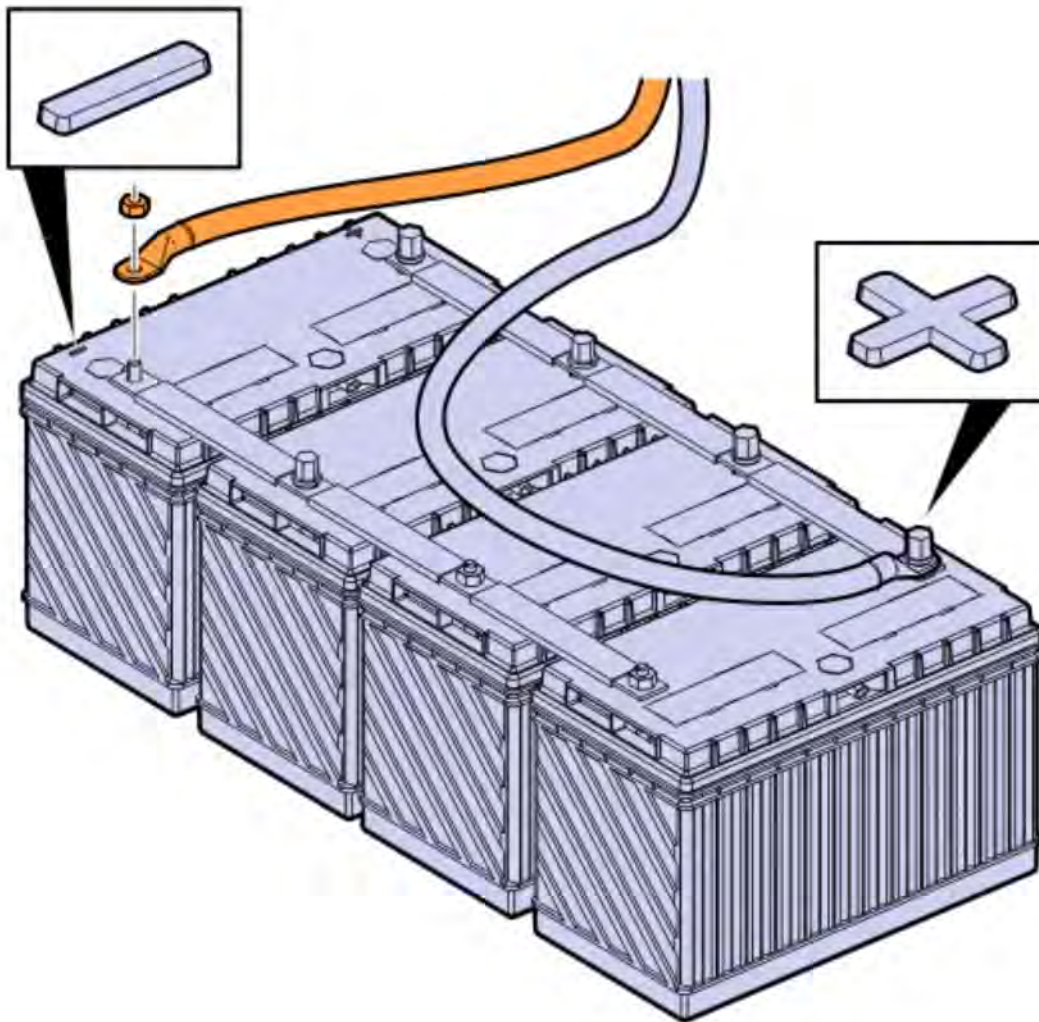

Battery Cable, Routing

1. Locate the positive and negative battery cables above the frame rail and behind the disconnect switch.

Note: Check the battery cables protective coating for heavy chaffing, cuts, excessive wear, exposed and oxidized copper wires. If any these conditions are present, replace cables as required.

Note: If the conditions listed above are not present, a double headed cable tie is still required to prevent battery cable chafing. Go to step 2.

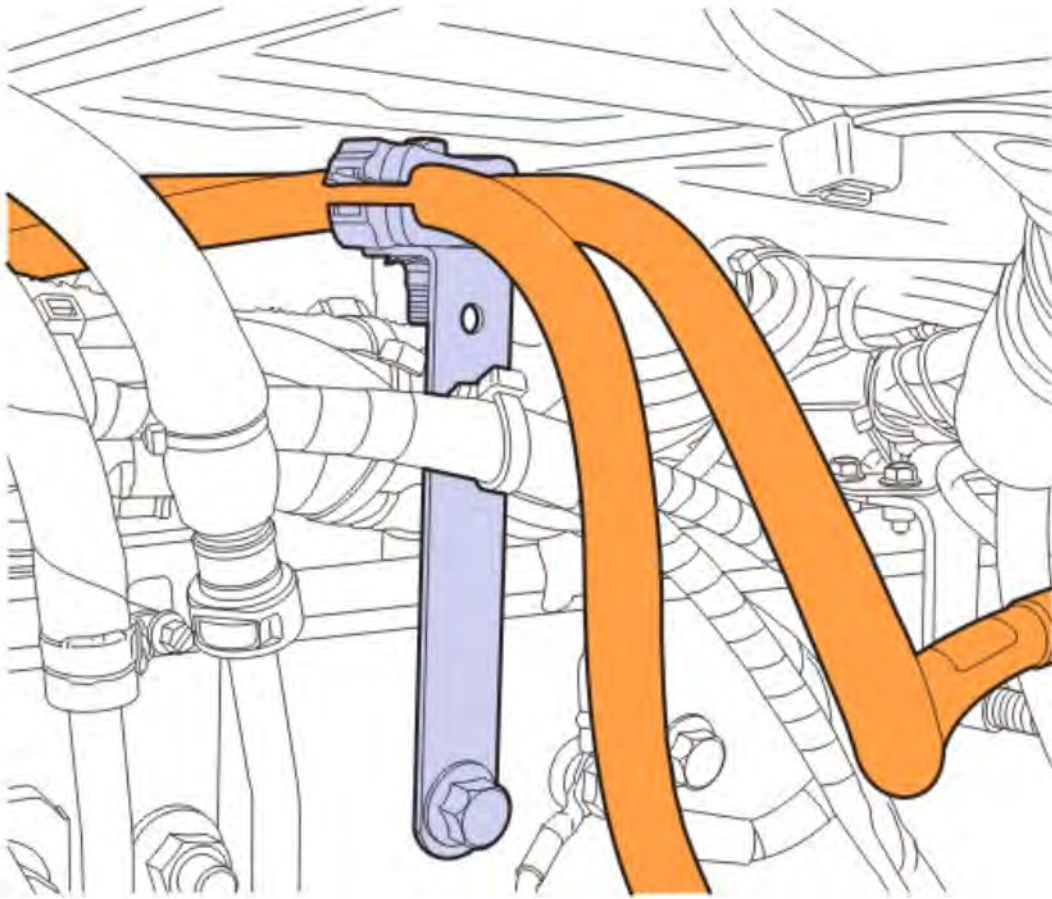

2. Install a double headed cable tie in the area as shown in the figure below.

Note: In some cases, a second double headed cable tie may be required to ensure separation of the positive and negative battery cables.

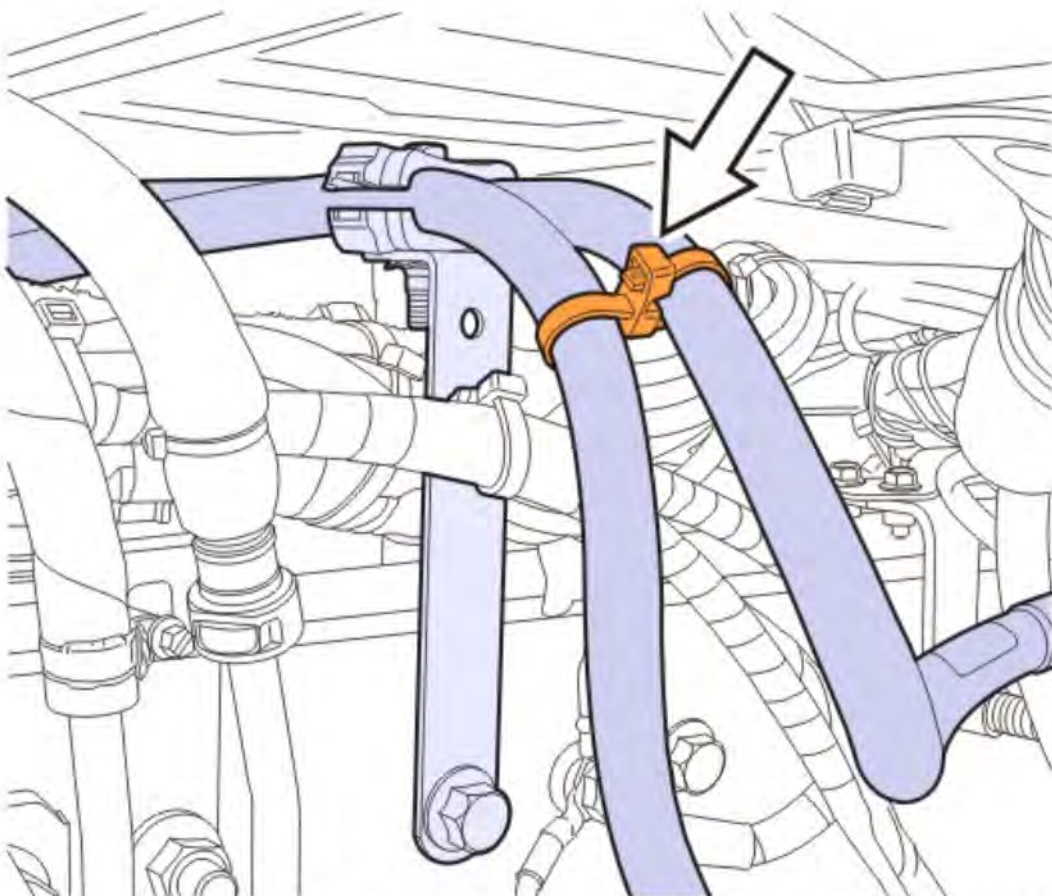

Commissioning the Truck for Operation

1. Connect the battery cable to the negative (ground) terminal.

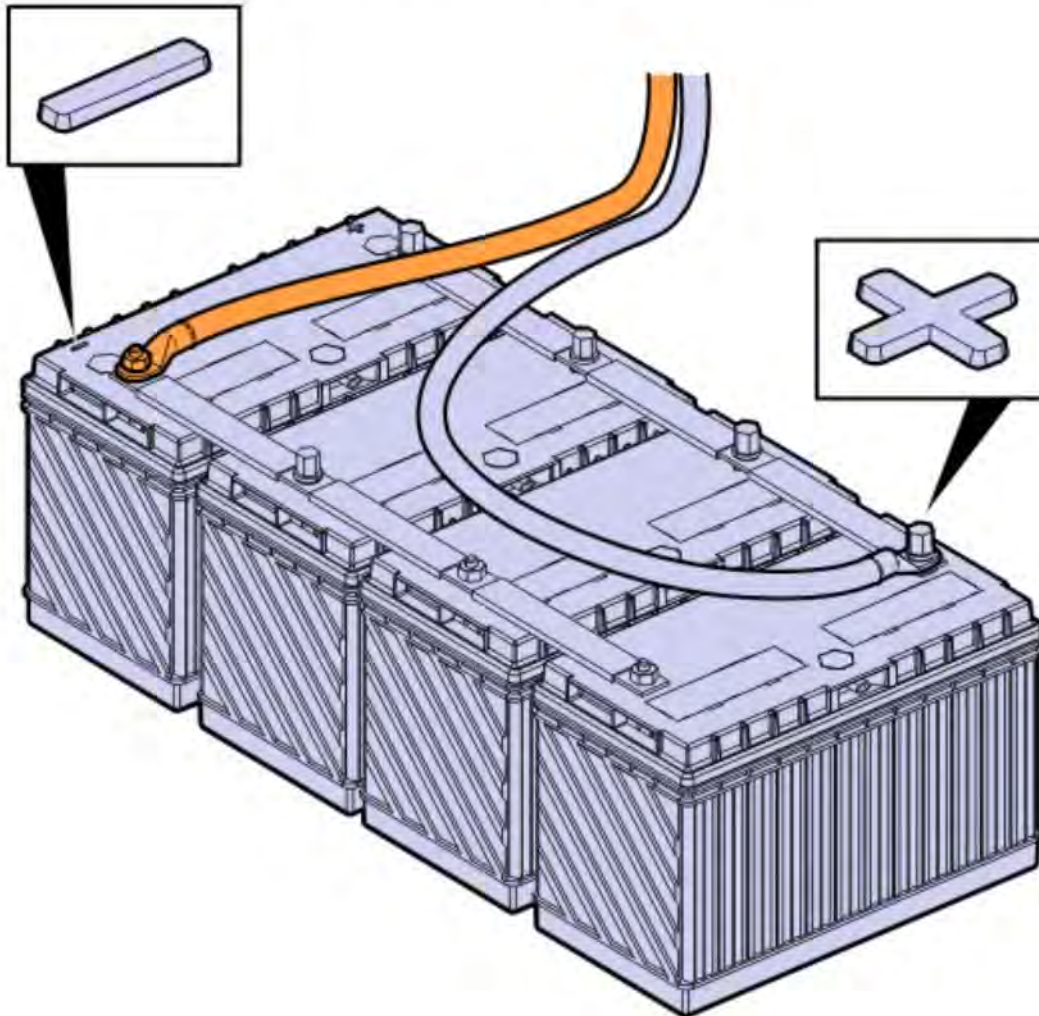

2. If applicable, install the side fairing.
3. Remove the wheel chocks.

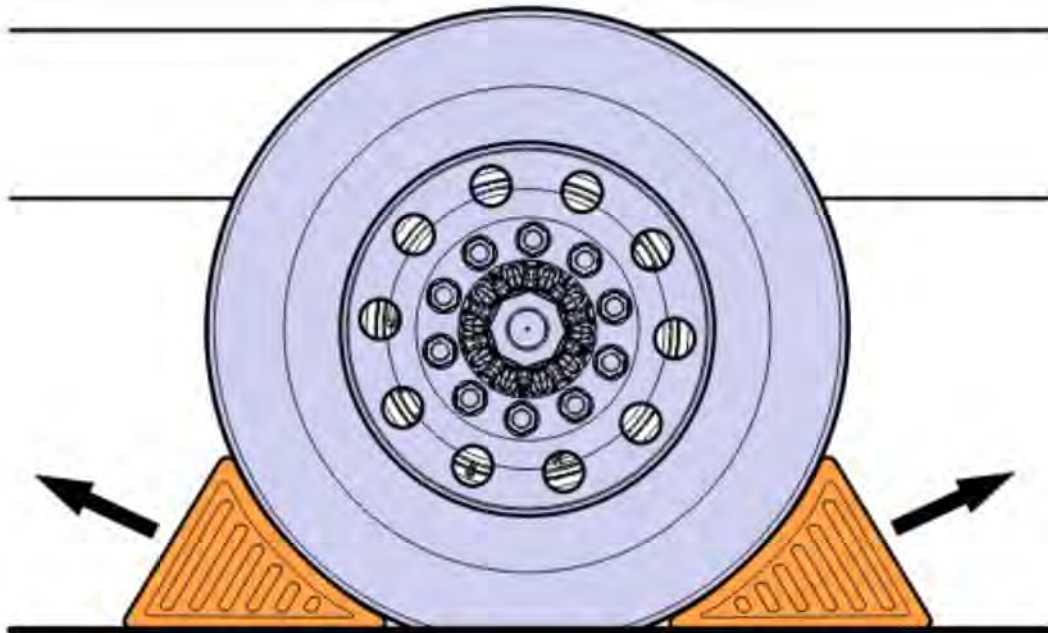

Warranty information

Reimbursement

| | | |
|--|-----------------------------------|---------------------------------|
| <p>This repair may be eligible for reimbursement if a product failure was experienced within time and mileage limits of the applicable Warranty coverage. Reimbursement is obtained via the normal claim handling process.</p> | <p>UCHP Reimbursement</p> | <p>eWarranty Reimbursement</p> |
| <p>Claim Type (used only when uploading from the Dealer Bus. Sys.)</p> | <p>01</p> | <p>01</p> |
| <p>Labor Code</p> | | |
| <p>Primary Labor Code (Cab Harness Insulation)</p> | <p>3717-02-09-01 0.5 hrs.</p> | <p>7246K-01-80 0.5 hrs.</p> |

Copyright to this documentation belongs to the Volvo Group. No reproduction, copying, change, amendment or other similar disposal is entitled without prior written consent by the Volvo Group

The information contained herein is current at the time of its original distribution, but is subject to change. The reader is advised that printed copies are uncontrolled.

| | | |
|-------------|----------|----------|
| Causal Part | 21962684 | 21962684 |
|-------------|----------|----------|

Issued by

Technical Service

VOLVO Trucks North America reserves the right to make any changes in design or to make additions to or upon its products without incurring any obligations to install the same on vehicles previously built.



1700-21-03-04 Oscilloscope

Simulation

Information >> Conditions >> Execution

Information

The button will open the program in a new window outside of Tech Tool
After the program has been opened, Tech Tool can be viewed by minimizing the window
When finished with the program below, it can be exited by closing the window
For best measurement results do not have the external power supply adapter connected to the PC.
A snapshot can be taken of the measurement by selecting the pause button in the Oscilloscope window

Action

Press the button below to open the program



Test result

Select one of the following alternatives

- OK
Not OK

Continue >

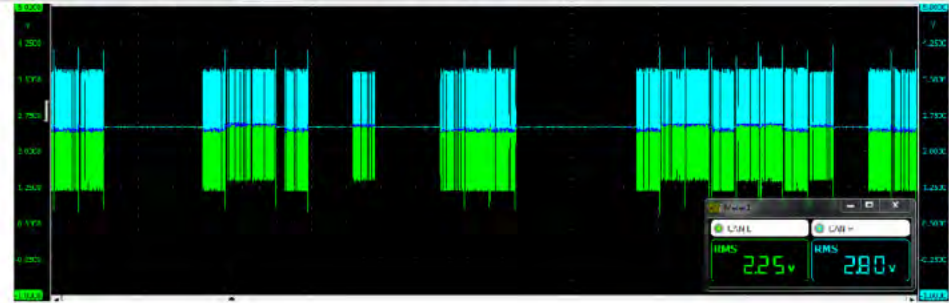

| Oscilloscope | Red probe | Black probe |
|--------------|-----------|--------------|
| Channel 1 | CAN L * | Ground point |
| Channel 2 | CAN H * | Ground point |

* See schematics for connector pins

3711-08-03-03 Data Links, Fault Tracing with Oscilloscope

Simulation

Information >> Conditions >> Execution

Information

The button will open the program in a new window outside of Tech Tool
After the program has been opened, Tech Tool can be viewed by minimizing the window

There are 2 type of tests

- Standard: Used for active faults
- Wiggle wire: Used for intermittent faults

Note: A battery charger can create measurement disturbances. Turn off the battery charger during the test

For best measurement results do not have the external power supply adapter connected to the PC
A snapshot can be taken of the measurement by selecting the pause button in the Oscilloscope window

When finished with the program below, it can be exited by closing the window

Tech tip

Action

Select one of the following alternatives

- Standard CAN 250 - 500 Kbits (J1939 or J2284)
- Wiggle wire CAN 250 - 500 Kbits (J1939 or J2284)
- Standard 10 Kbits (J1587)
- Wiggle wire 10 Kbits (J1587)

Press the button below to open the program



Evaluation

- Standard CAN
- Wiggle wire CAN
- Standard J1587
- Wiggle wire J1587

Test result

Select one of the following alternatives

- OK
- Not OK

Continue

ISO 14229 BB2(DL2)

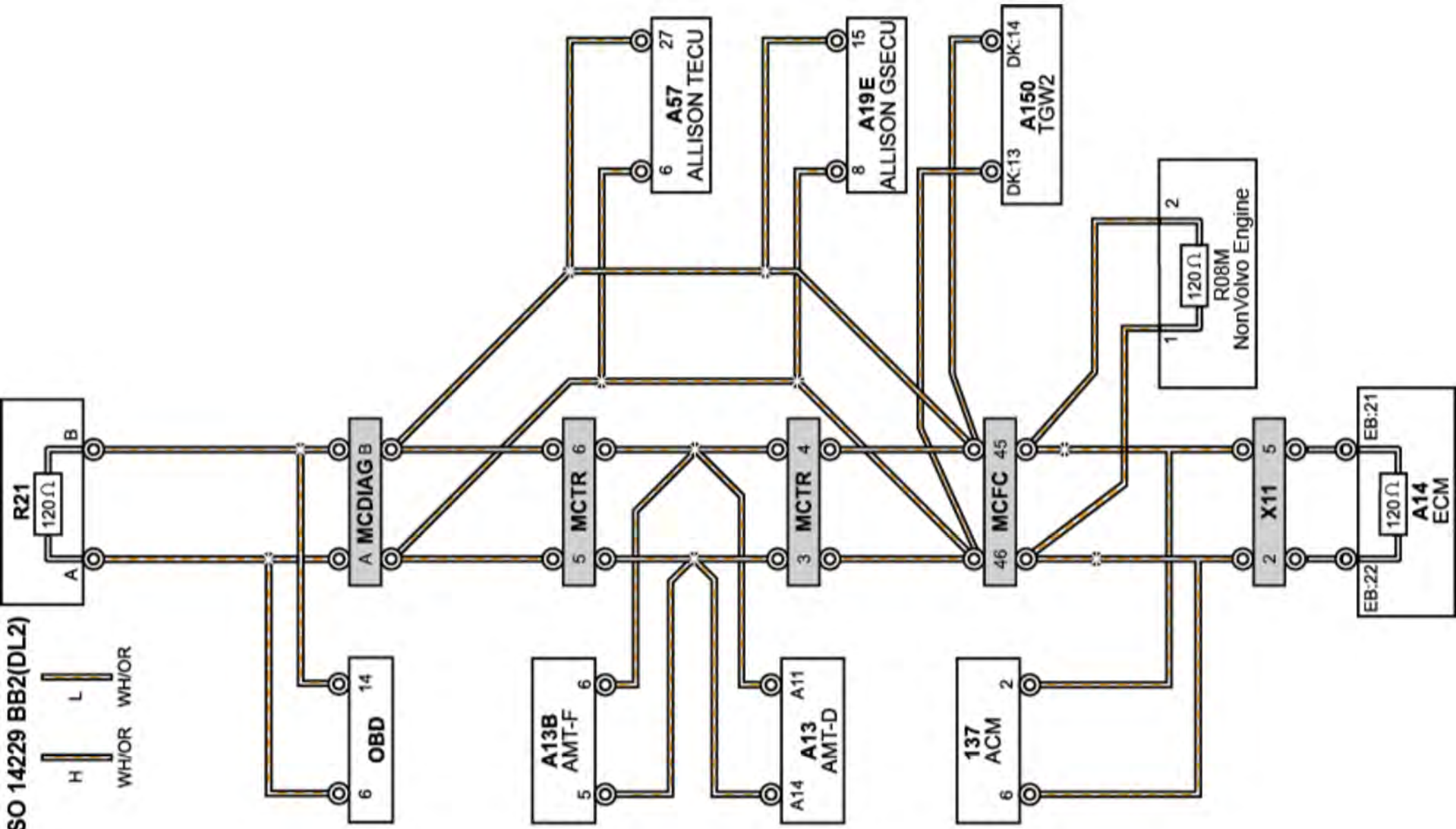

SAE J1587 DL4

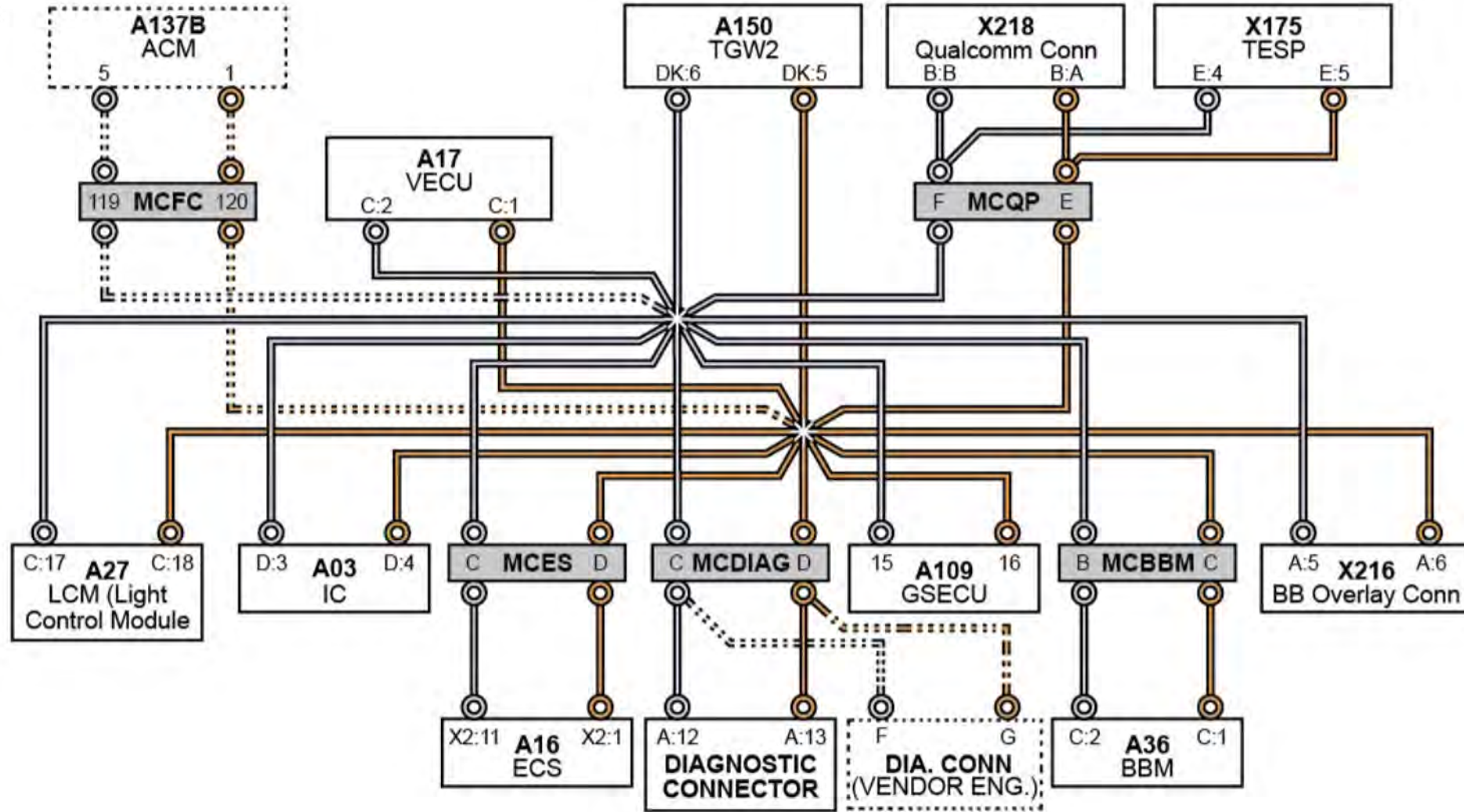

Engine Subnet (DL7)

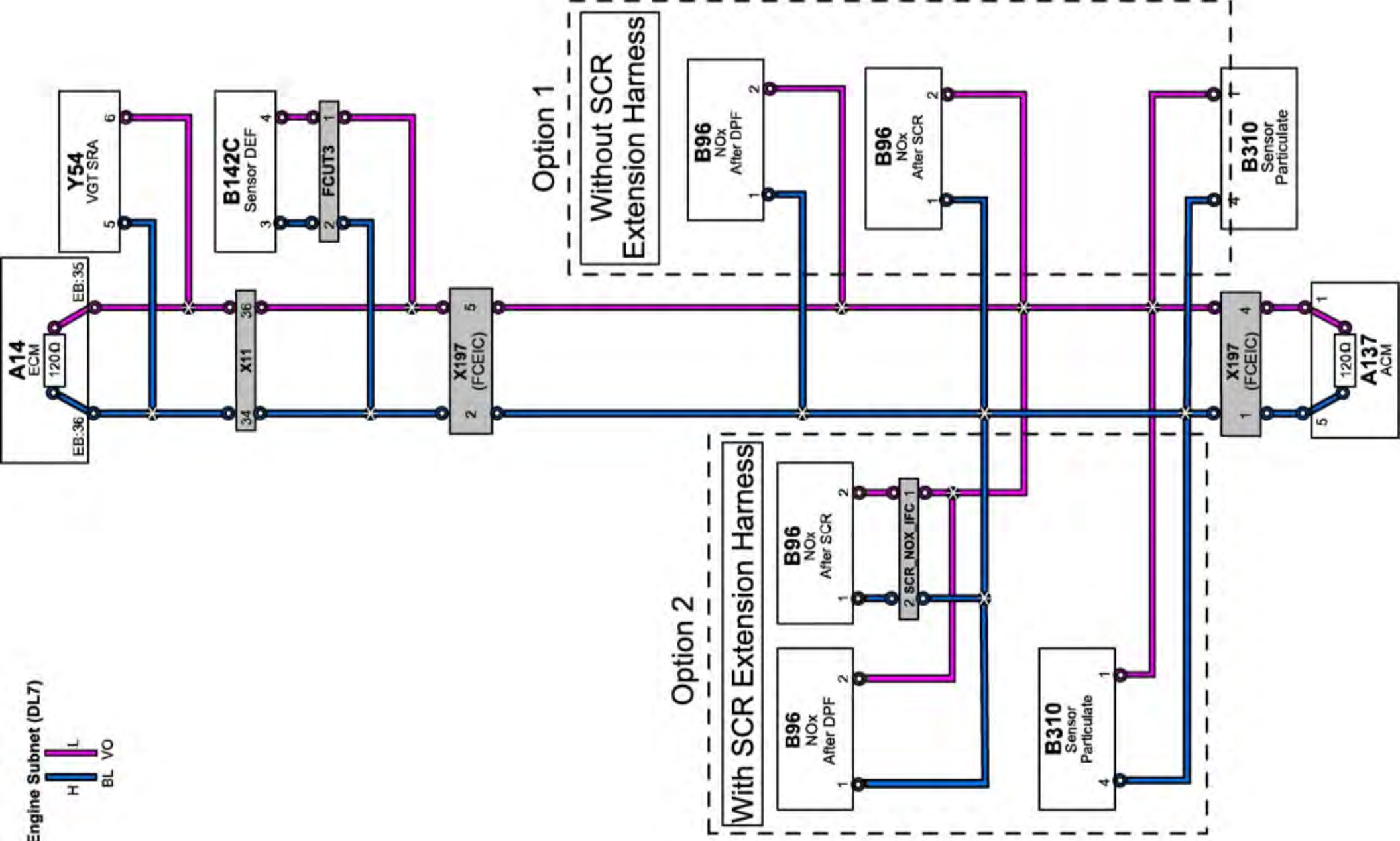
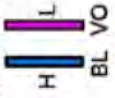

Powertrain Net (DL9)

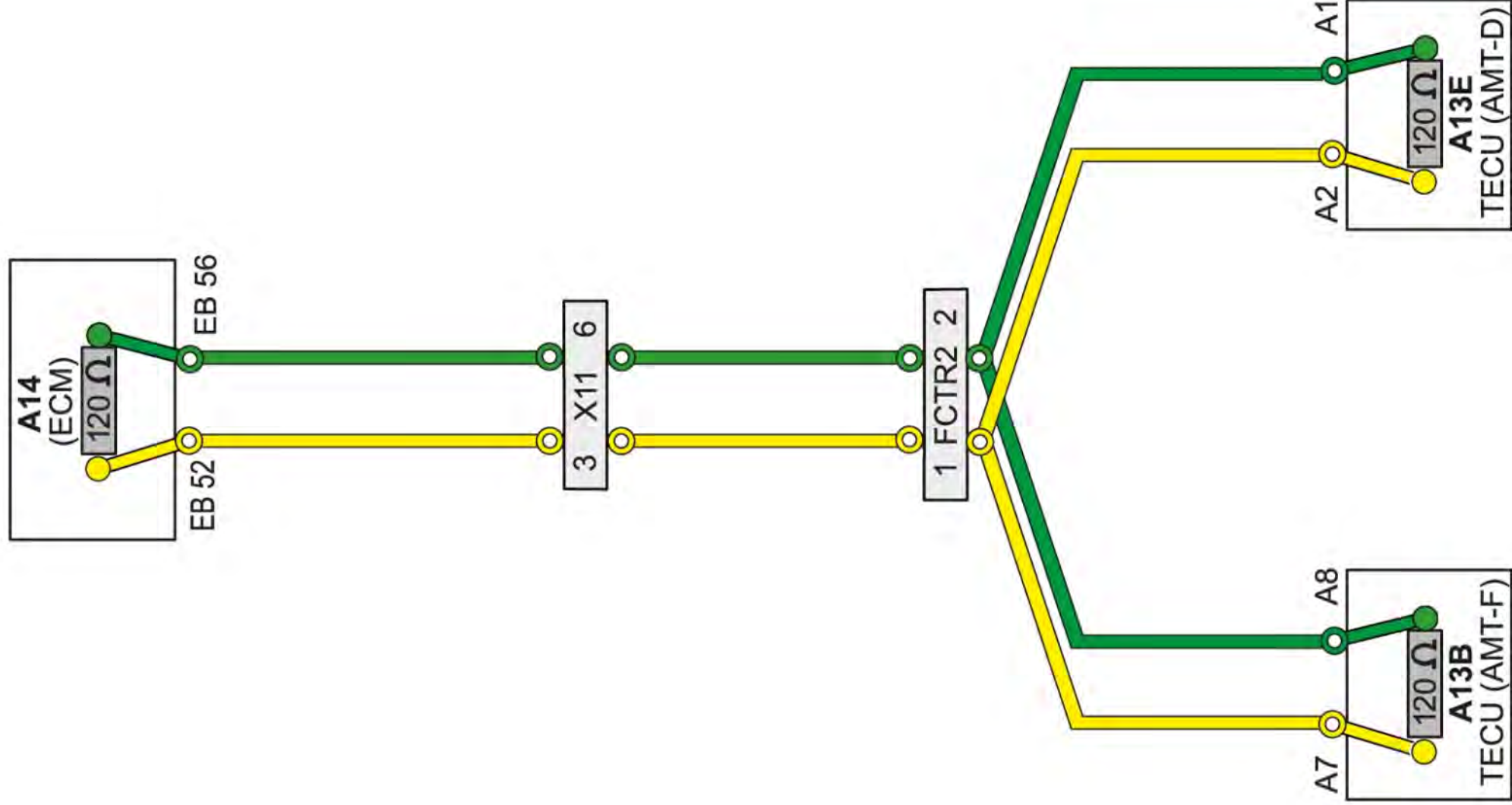

Data Link Analysis

DL7

J1939 Powertrain Sub-network
Engine Subnet

Data link ID Cross Reference

| Schematic ID | Engineering ID | Alternate ID | Tech Tool ID |
|---------------------|--|----------------------|---------------------------|
| DL1 | J1939 Main Network | SAE J1939 (DL1) | J1939 BB1 (DL1) |
| DL2 | 500Kb ISO Network | ISO 14229 (DL2) | ISO 14229 BB2 (DL2) |
| DL3 | J1939 Infotainment Sub network | J1939-3 (DL3) | J1939 Infotainment (DL3) |
| DL4 | J 1708/J1587 Network | SAE J1708/1587 (DL4) | SAE J1587 (DL4) |
| DL5 | VECU Bodybuilder buffered data Subnetwork | | VECU Bodybuilder (DL5) |
| DL6 | J1939 HVAC Subnetwork | | J1939 HVAC Sub (DL6) |
| DL7 | J1939 Powertrain Sub-network | | Engine Subnet (DL7) |
| DL8 | Allison/Eaton Transmission Subnetwork DL9 | | Vendor Trans (DL8) |
| DL9 | iShift Powertrain Subnetwork | ISO-2 (DL9) | Powertrain Subnet (DL9) |
| DL10 | J1939 500Kb Network (Cummins OBD Diagnostics 2016) | | J1939 Cummins 500K (DL10) |
| DL11 | IC Data link radio | | IC (DL11) |

NOx, Good reading , Teal/Green Trace = NOx, pins 1 & 2, Red/Blue Trace = ACM, pins 1 & 5

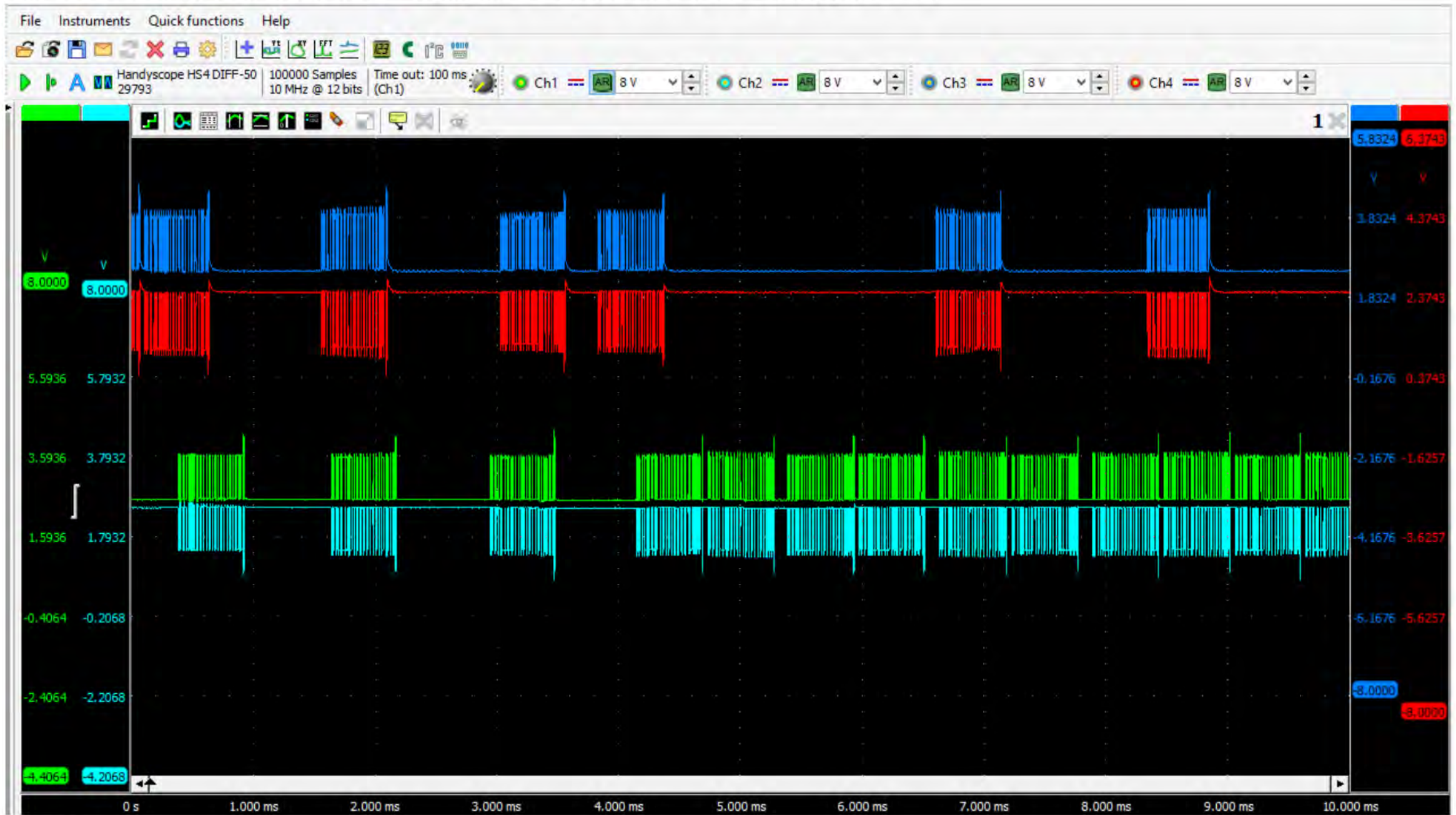

NOx Offline, Circuit fuse removed, Teal/Green Trace = NOx, pins 1 & 2, Red/Blue Trace = ACM, pins 1 & 5

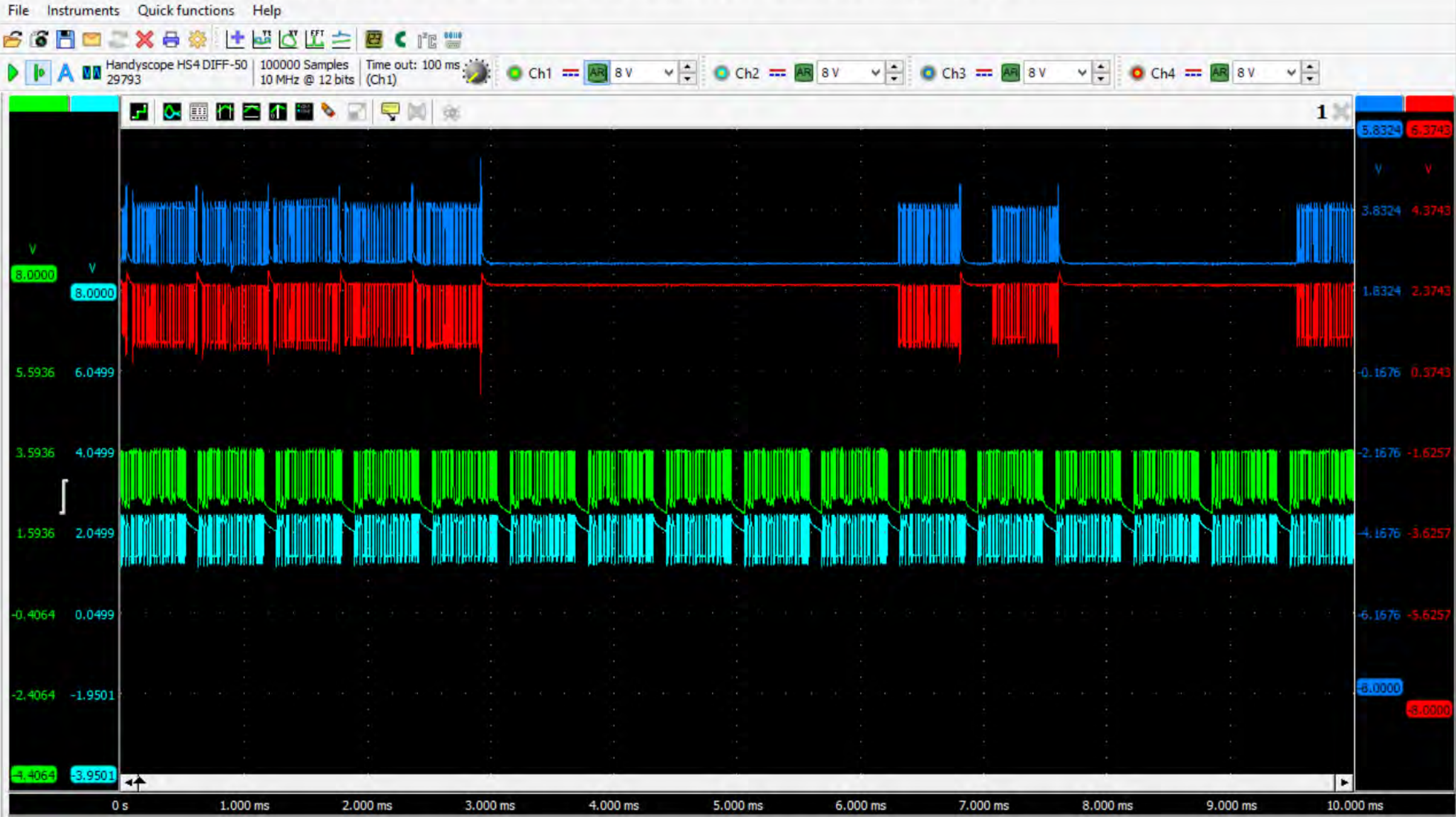

NOx 1939H Short to Ground, Teal/Green Trace = NOx, pins 1 & 2, Red/Blue Trace = ACM, pins 1 & 5

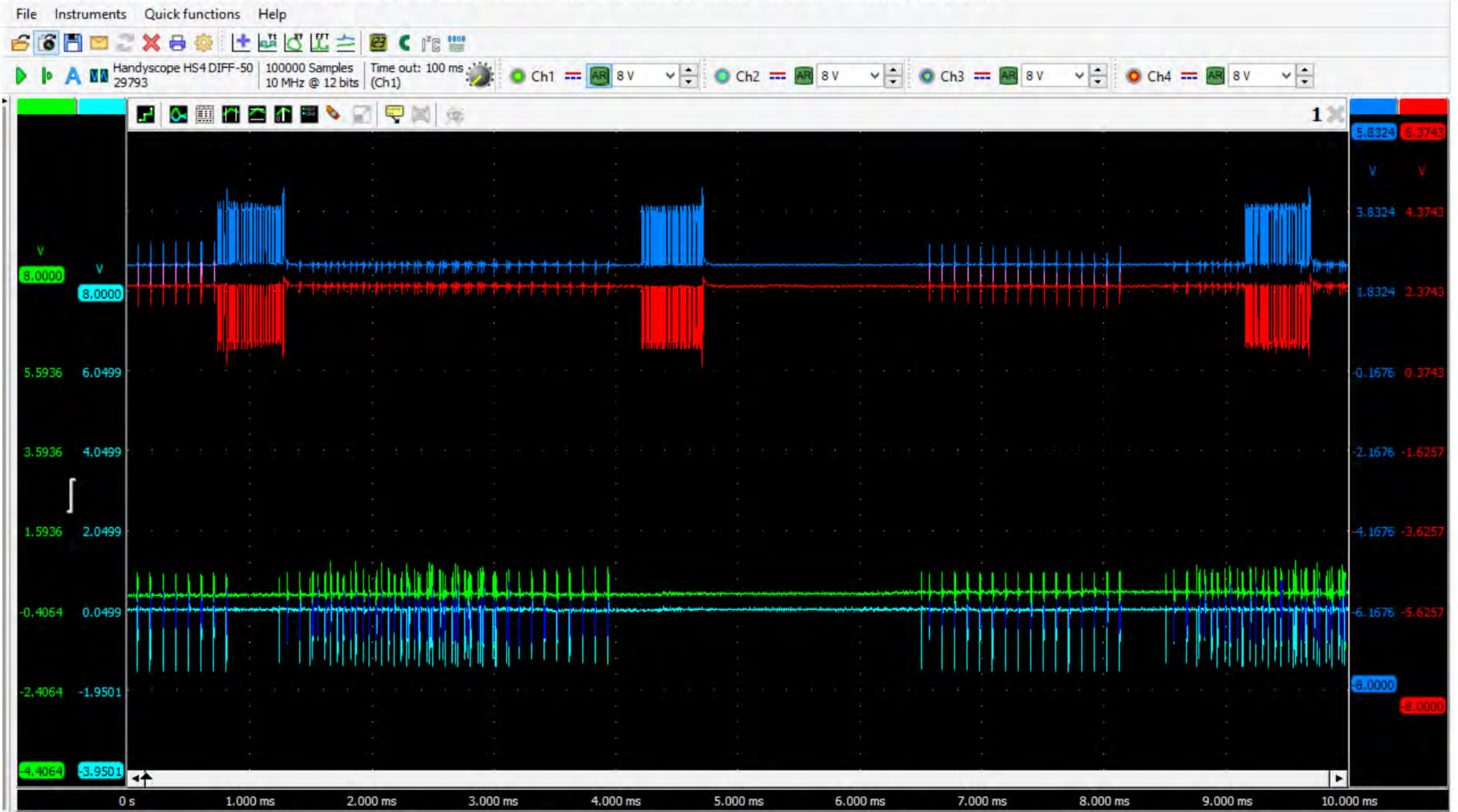

NOx 1939L Short to Ground, Teal/Green Trace = NOx, pins 1 & 2, Red/Blue Trace = ACM, pins 1 & 5

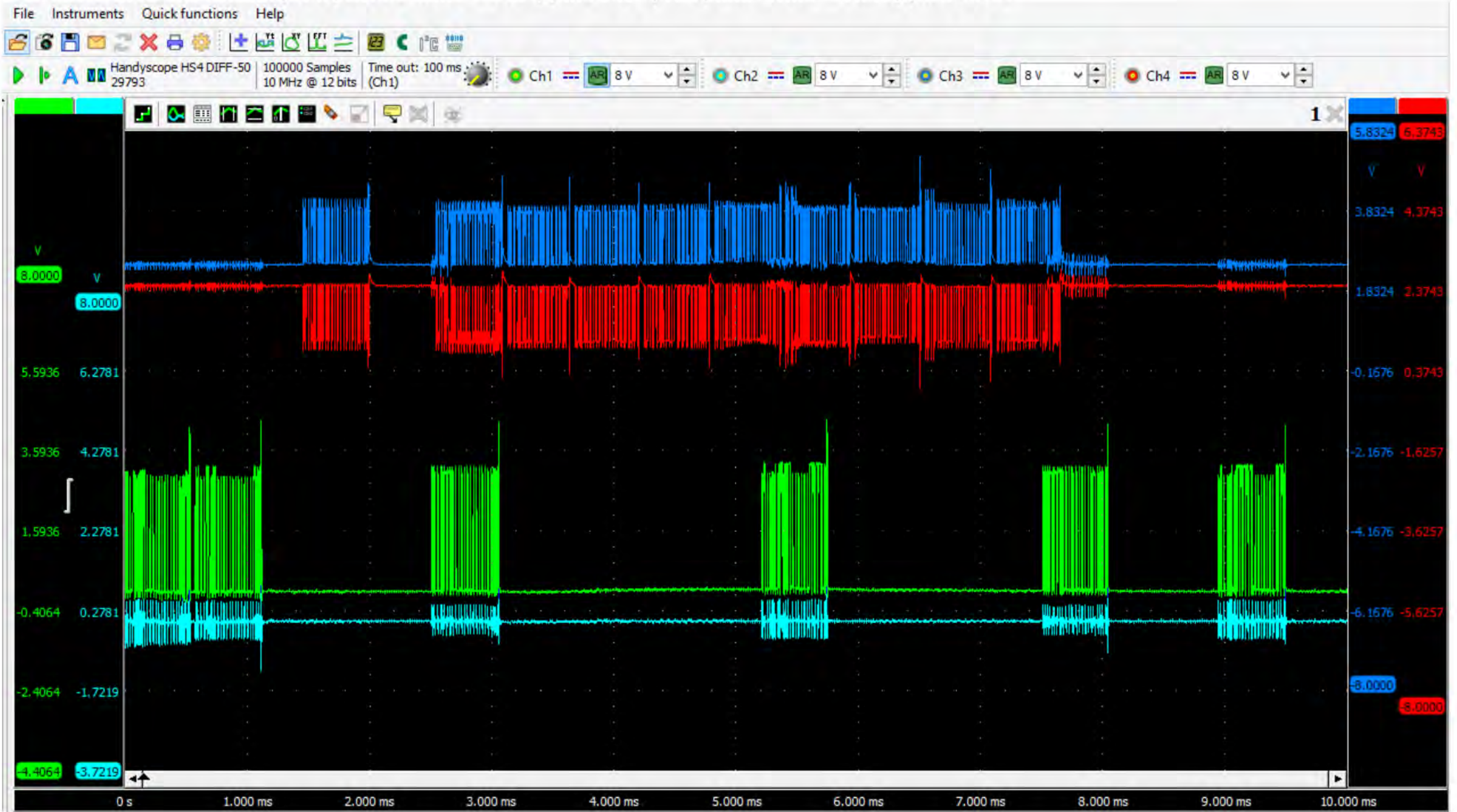

PM Sensor, Good Reading , Teal/Green Trace = PM Sensor, pins 1 & 4, Red/Blue Trace = ACM, pins 1 & 5

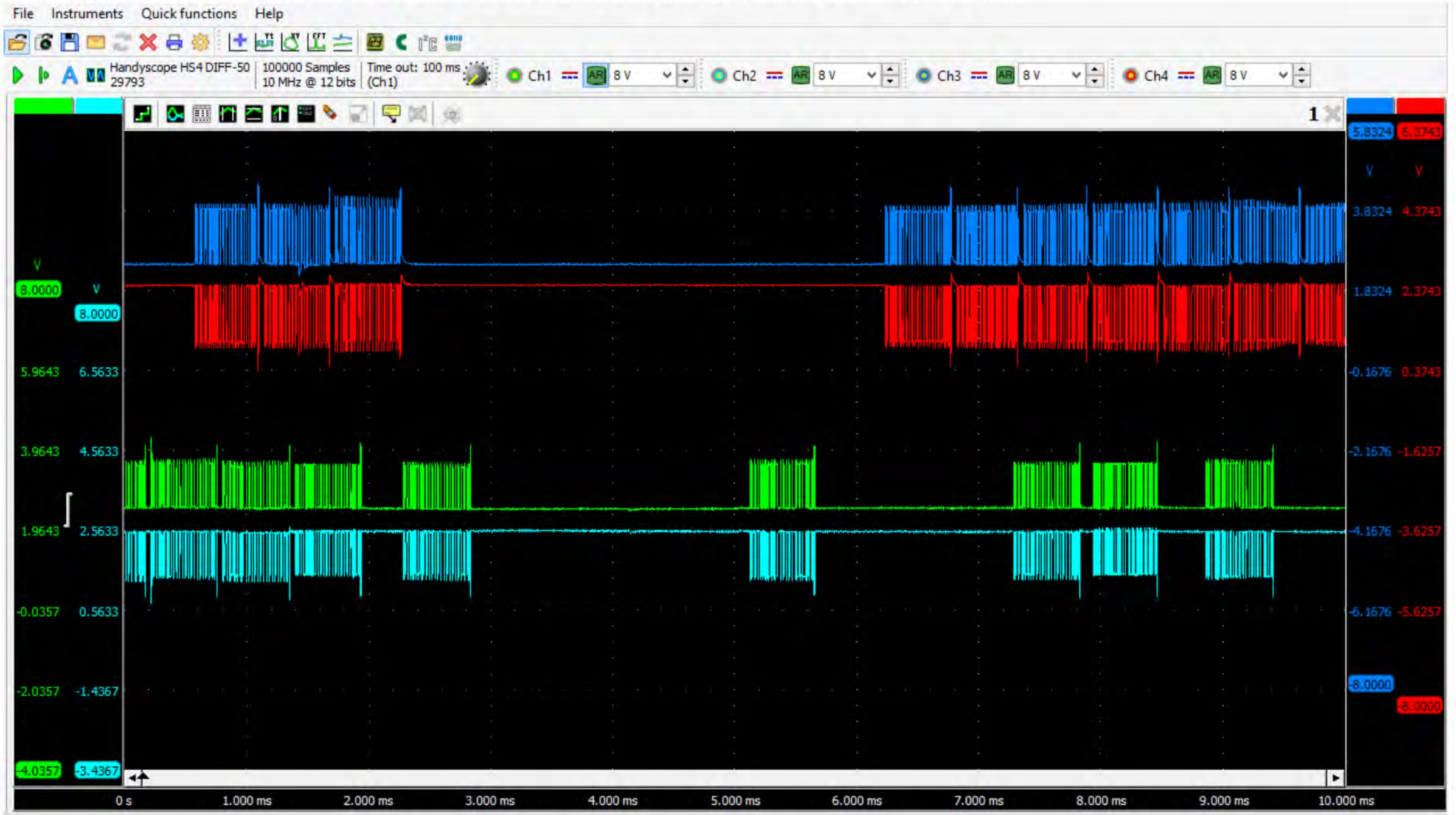

PM Sensor Offline, Teal/Green Trace = PM Sensor, pins 1 & 4, Red/Blue Trace = ACM, pins 1 & 5

File Instruments Quick functions Help



HandyScope HS4 DIFF-50 100000 Samples Time out: 100 ms (Ch1) 10 MHz @ 12 bits

Ch1 8 V Ch2 8 V Ch3 8 V Ch4 8 V

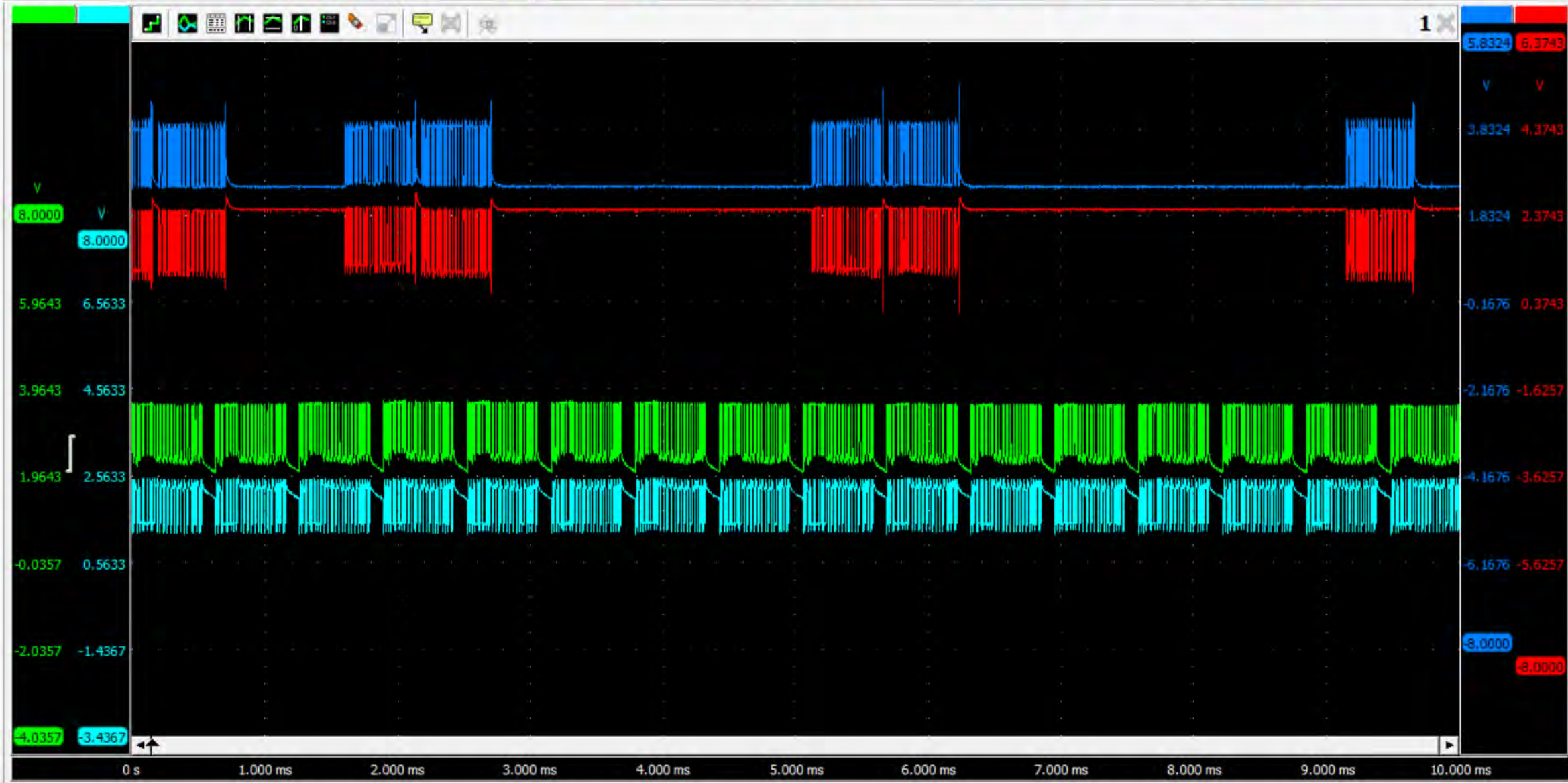

PM Sensor 1939H Short to Ground, Teal/Green Trace = PM Sensor, pins 1 & 4, Red/Blue Trace = ACM, pins 1 & 5

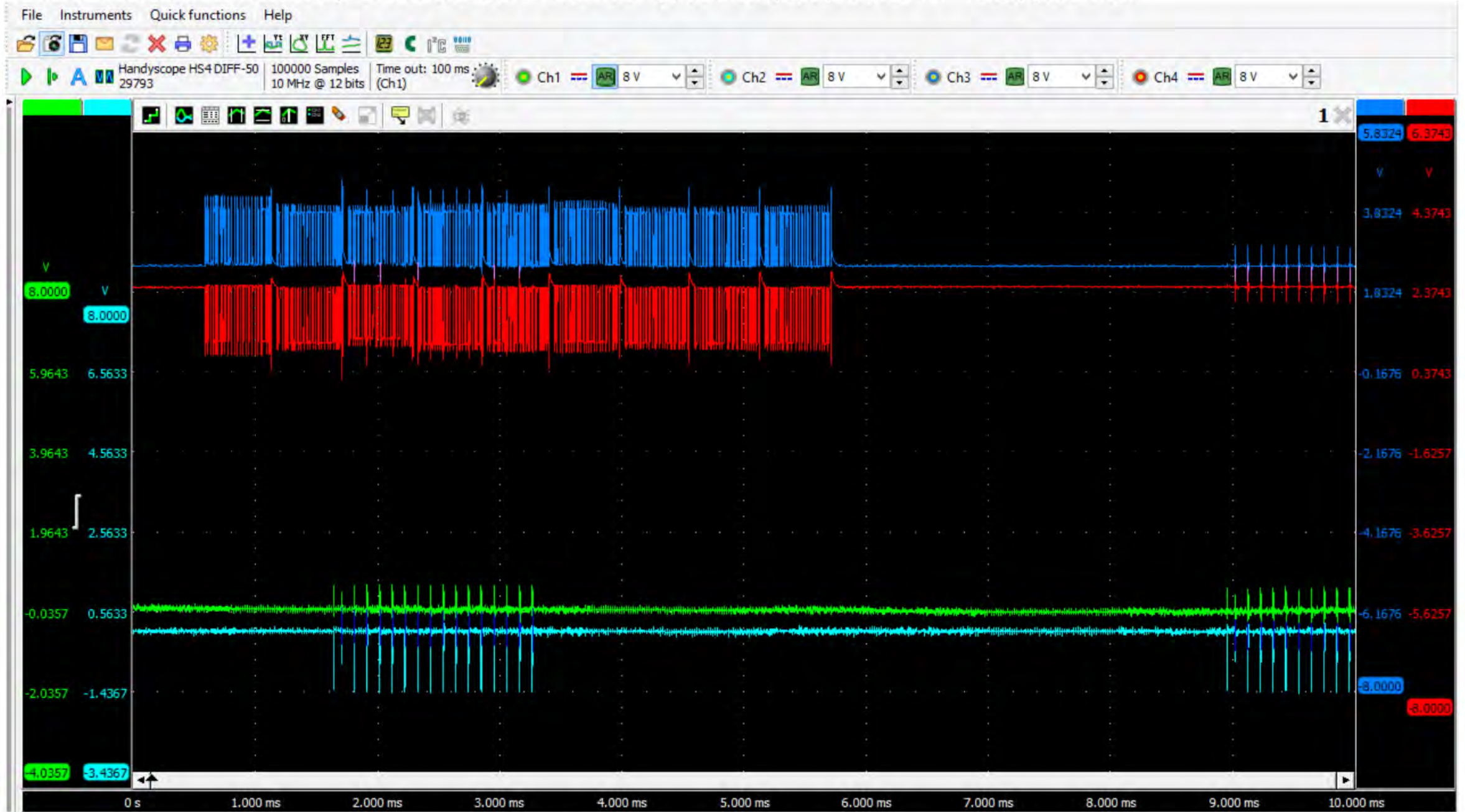

PM Sensor 1939L Short to Ground, Teal/Green Trace = PM Sensor, pins 1 & 4, Red/Blue Trace = ACM, pins 1 & 5

