

Drum flange bolt torque specification inspection

Date: May 03, 2022
Bulletin Name: MXR-TSIB-035
Model: Bridgemaster (93) and Standard (90) Mixer
Model Year: 2021 and 2022
Units Affected: Units delivered to customer between 03/01/2021 and 02/28/2022

Purpose:

Inspection and possible rework required on drum flange bolt torquing specifications on certain Rear Discharge Mixer vehicles.

Notice:

- This bulletin should be read and understood in its entirety before performing this procedure.
- All procedures outlined in the bulletin must be performed by skilled service personnel. Refer to the product service manual for descriptions of maintenance procedures.

SAFETY NOTICE

Perform your company's Lockout/Tagout procedure. If your company does not have a Lockout/Tagout procedure, follow OSHA 1910.147 and 1910.146 Confined Space as appropriate.

SAFETY NOTICE

Use appropriate Personal Protective Equipment (PPE) as required by your company.

Tools and Equipment Required:

Customer to supply:

- Torque wrench (capability up to 212 ft.-lbs.)
- Tamper-proof indicator paste (such as Torque Seal®), paint pen, or permanent marker

Parts Required:

Item	PN	Description	Qty.
1	0100565	WASH,FLT .62X1.31X.12 ZY HDN	18
2	1470296	SCR,HEX,.62-11X2,LOCTITE,ASSY	18

Procedure:

1. Perform your company's Lockout/Tagout procedure. If your company does not have a Lockout/Tagout procedure, follow OSHA 1910.147 and 1910.146 Confined Space as appropriate.
2. Check the torque on all 18 drum flange bolts. If a bolt turns during this check, then all bolts and washers, regardless if they do not turn, must be removed and replaced with new bolts (PN 1470296) and washers (PN 0100565).

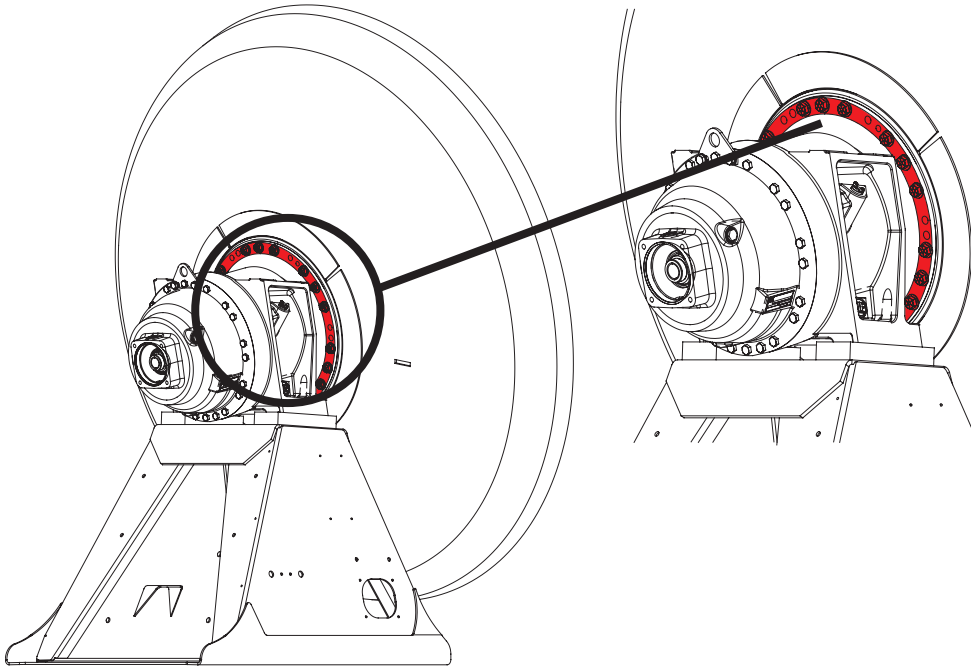

3. Clean the bolt threads.
4. Install the bolt(s) and washer(s) and tighten to 212 ft.-lbs. using a torque wrench.

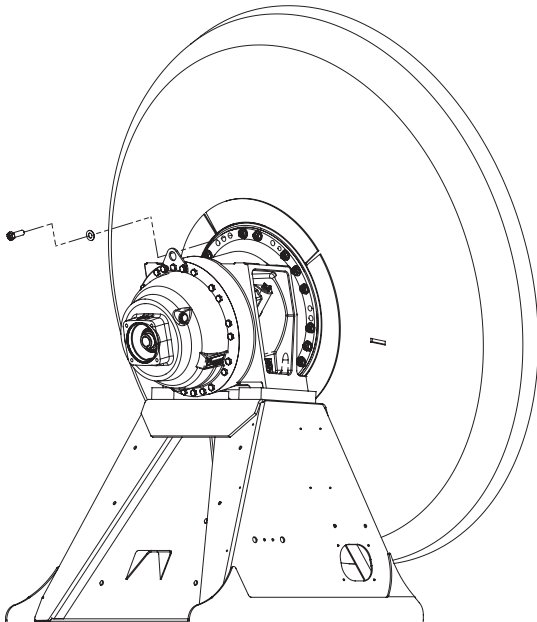

5. Mark each bolt with the marker (or paint pen or tamper-proof paste) to signify that bolt has been torqued.
6. Procedure is complete. Remove your company's Lockout/Tagout procedure. If your company does not have a Lockout/Tagout procedure, follow OSHA 1910.147 and 1910.146 Confined Space as appropriate.
7. Return truck to service.



(888) 686-7278

www.streetsmartparts.com