



# Service Bulletin

Bulletin No.: 22-NA-007

Date: May, 2022

## TECHNICAL

**Subject:** Poor Engine Performance in Extremely Cold Weather Conditions for LE2 Engines, Charge Air Cooler (CAC) Icing - Malfunction Indicator Lamp (MIL) Illuminated, DTC P0299, P0234, P0236, P2227, P00C7 Set

Brand:	Model:	Model Year:		VIN:		Engine:	Transmission:
		from	to	from	to		
Chevrolet	Cruze	2016	2019	—	—	1.4L Turbo (LE2)	—

<b>Involved Region or Country</b>	North America
<b>Condition</b>	<p>Some customers may comment that when driving short distances and/or slow speed driving cycles, their vehicle experiences one or several of the following conditions within the first 10 to 15 minutes of vehicle operation in extremely cold weather conditions (-18°C or less / 0°F or less):</p> <ul style="list-style-type: none"> <li>• Loss of power</li> <li>• Hesitation on acceleration</li> <li>• Stalling condition</li> <li>• May also notice a Malfunction Indicator Lamp illuminated</li> <li>• After driving for a period of time, the driveability issues seem to diminish.</li> </ul> <p>This condition may also cause an increase in crankcase pressure, creating oil leaks at seals and gaskets.</p> <p>Technicians may find one or more of the following DTCs set:</p> <ul style="list-style-type: none"> <li>• P0234</li> <li>• P0236</li> <li>• P0299</li> <li>• P2227</li> <li>• P00C7</li> </ul>
<b>Cause</b>	This condition may be caused by ice accumulation in the charge air cooler (CAC) or turbocharger wastegate regulator solenoid valve (TCV), causing improper boost pressures.
<b>Correction</b>	<p>If any of the above conditions are present, allow time for possible ice build up in the CAC to melt by allowing the vehicle to thaw in a warm environment.</p> <p>Follow the Service Procedure below once the vehicle has had time to thaw.</p>

**Important:** Allow time for the vehicle to thaw in a warm environment to avoid damaging or breaking parts that may be required to be re-installed.

## Service Procedure

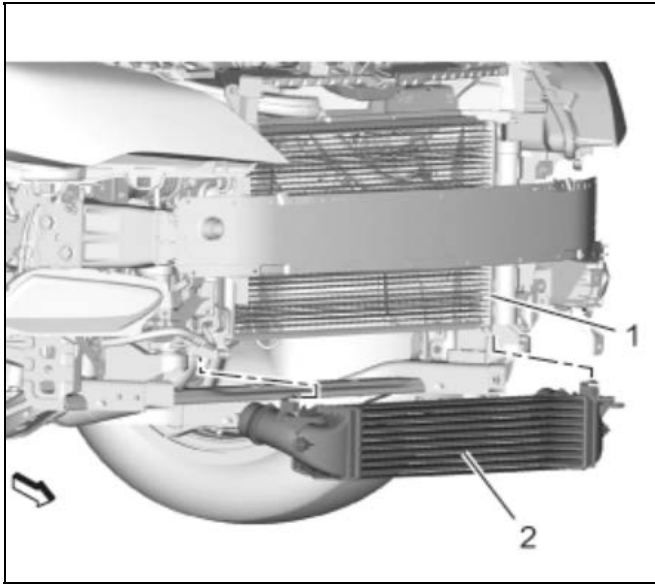

4171562

1. Remove the CAC (2) and drain any moisture built up. Refer to *Charge Air Cooler Replacement* in SI.

**Important: Do Not** perform an oil change if the oil change was recently done.

- If the oil change was recently done and no signs of moisture have been confirmed, proceed to Turbocharger Wastegate Regulator Solenoid Valve (TCV) Thermo-Wrap procedure.
  - If the oil change was not previously done or moisture has been found in the oil, proceed to step 2.
2. Perform an oil change. Refer to *Engine Oil and Oil Filter Replacement* in SI.

## Turbocharger Wastegate Regulator Solenoid Valve (TCV) Thermo-Wrap

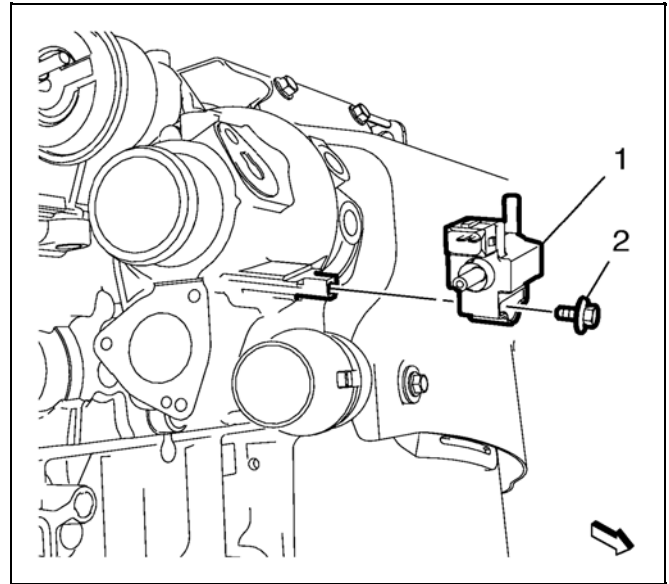

3686945

1. Remove the turbocharger wastegate regulator solenoid valve (TCV) (1). Refer to *Turbocharger Wastegate Regulator Solenoid Valve Replacement* in SI.
2. Drain the TCV by turning the valve upside down.
3. Using clean shop air regulated to 80-100 PSI, blow through all three ports (1, 2 & 3) for 5 seconds each.

**Note:** Check port #2 to assure the spring gets lifted off the seat. This will be determined by the compressed air not dead heading when applied to port #2. When applying air to this port a small amount of air should be observed at port #3 and even less air will be noticed at port #1. If this does not happen, the TCV plunger may have hardened deposits from hot operating conditions which will impede TCV plunger movement, and the turbocharger wastegate regulator solenoid valve should be replaced.

⇒ Repeat step 3 twice.



6046310

4. Prior to reinstalling the TCV, pre-position the thermal wrap. This will aid in installation of the wrap once the TCV is reinstalled.



6046314

**Note:** The end result of the wrap will surround the TCV as shown in the graphic above. Do not snap the wrap until step 6.

5. Install the TCV. Refer to *Turbocharger Wastegate Regulator Solenoid Valve Replacement* in SI.



6046334

6. Once the mounting bolt and hoses are properly installed, pull the lower portion of the wrap upward, and snap it into position.
7. Clear all DTCs using GDS and evaluate.

### **Turbocharger/Supercharger Boost Pressure Sensor Inspection**

**Important:** Only perform steps 1-5 if DTC P0299 or P0234 is set.

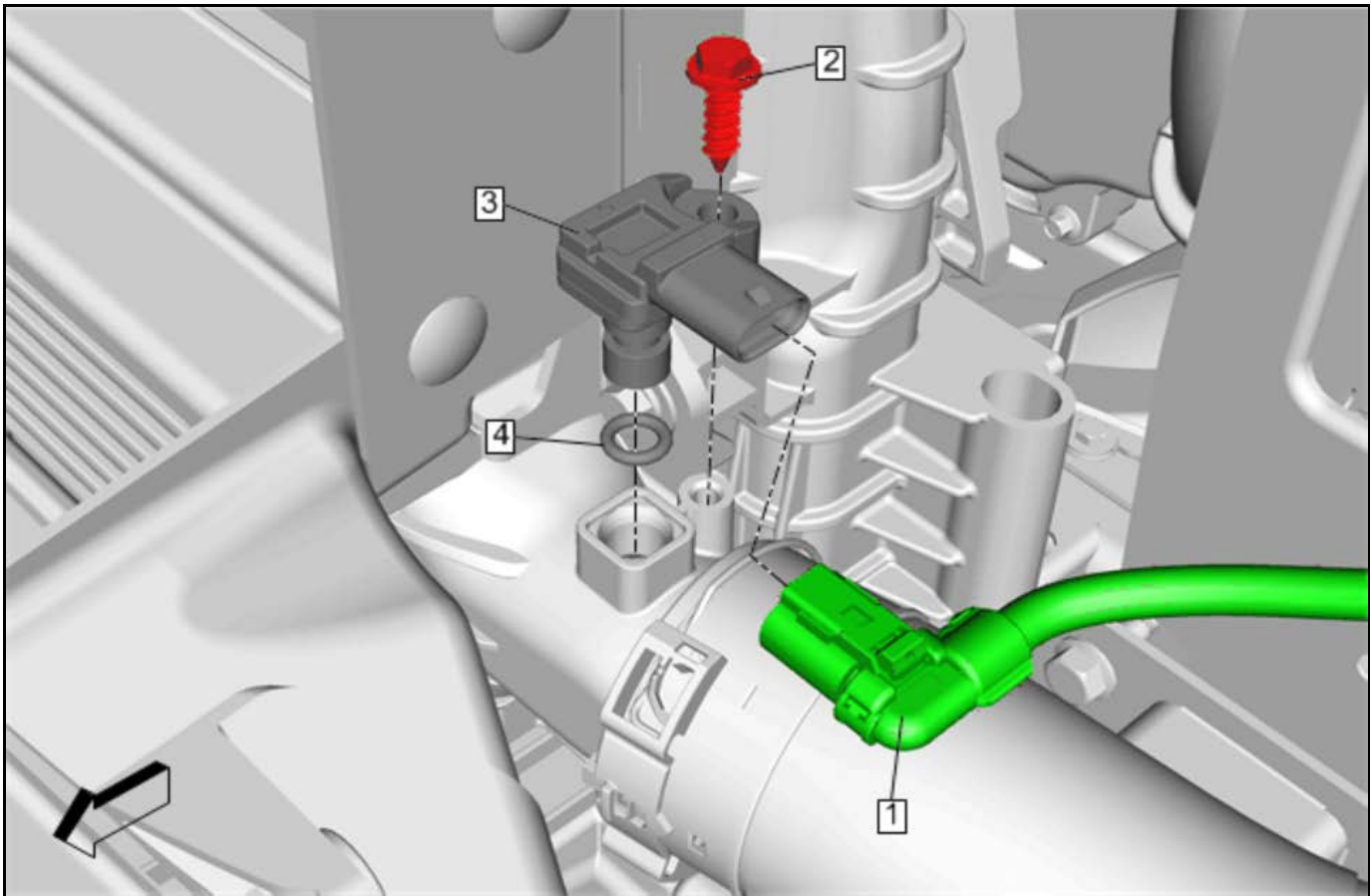

4108751

1. Remove the turbocharger Air Pressure sensor (3). Refer to *Turbocharger/Supercharger Boost Pressure Sensor Replacement* in SI.



4910683

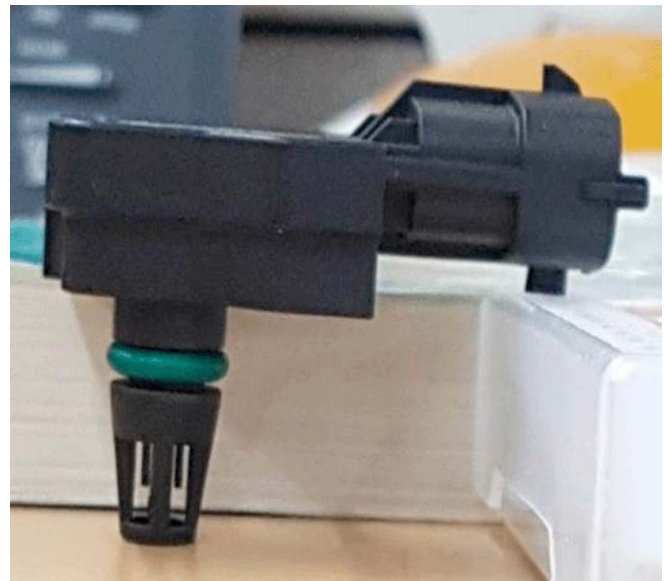

5020216

**Important:** Due to the sensitivity of the sensor, **Do Not** use any chemical cleaners including water and **Do Not** use compressed air to remove contaminants.

2. Inspect the sensor for any contaminants.

3. Allow time for any ice build-up to melt by placing the sensor port down.
4. Clean the sensor with a clean towel.
5. Install the sensor. Refer to *Turbocharger/Supercharger Boost Pressure Sensor Replacement* in SI.

## Engine Control Module Programming

**Important:** Updated Engine Control Module calibration: The updated calibration will enable a revised transmission shift pattern during cold weather operation which does not use overdrive as frequently. As a result, the customer may notice elevated engine RPMs during highway operation. This operating mode will reduce the potential for ice to build up inside the charge air cooler, and the potential for setting P0299 or P0234 diagnostic codes.

**Caution:** Before downloading the update files, be sure the computer is connected to the internet through a network cable (hardwired). DO NOT DOWNLOAD or install the files wirelessly. If there is an interruption during programming, programming failure or control module damage may occur.

- Ensure the programming tool is equipped with the latest software and is securely connected to the data link connector. If there is an interruption during programming, programming failure or control module damage may occur.
- Stable battery voltage is critical during programming. Any fluctuation, spiking, over voltage or loss of voltage will interrupt programming. Install a GM Authorized Programming Support Tool to maintain system voltage. Refer to [www.gmdesolutions.com](http://www.gmdesolutions.com) for further information. If not available, connect a fully charged 12V jumper or booster pack disconnected from the AC voltage supply. DO NOT connect a battery charger.
- Follow the on-screen prompts regarding ignition power mode, but ensure that anything that drains excessive power (exterior lights, HVAC blower motor, etc) is off.
- Please verify that the radio time and date are set correctly before inserting USB drive into vehicle for programming, **otherwise an error will result.**
- Clear DTCs after programming is complete. Clearing powertrain DTCs will set the Inspection/Maintenance (I/M) system status indicators to NO.

**Important:** The service technician always needs to verify that the VIN displayed in the TLC left side drop down menu and the top center window match the VIN plate of the vehicle to be programmed prior to using Service Programming System 2 (SPS2) for programming or reprogramming a module.

- For the TLC application, service technicians need to always ensure that the power mode (ignition) is "ON" before reading the VIN from the vehicle's VIN master module and that they do not select a VIN that is already in the TLC application memory from a previous vehicle.
- If the VIN that shows up in the TLC top center window after correctly reading the VIN from the vehicle does not match the VIN plate of the vehicle, manually type in the VIN characters from the vehicle VIN plate into the TLC top center window and use these for programming or reprogramming the subject module with the correct vehicle VIN and software and/or calibrations.

- The Engine Control Module (ECM) is the master module (for VIP vehicles) that TLC reads to determine the VIN of the vehicle. If the VIN read from the vehicle by TLC does not match the VIN plate of the vehicle, the ECM also needs to be reprogrammed with the correct VIN, software and calibrations that match the vehicle's VIN plate.
- The Body Control Module (BCM) is the master module (for GEM vehicles) that TLC reads to determine the VIN of the vehicle. If the VIN read from the vehicle by TLC does not match the VIN plate of the vehicle, the BCM also needs to be reprogrammed with the correct VIN, software and calibrations that match the vehicle's VIN plate.

**Caution:** Be sure the VIN selected in the drop down menu (1) is the same as the vehicle connected (2) before beginning programming.

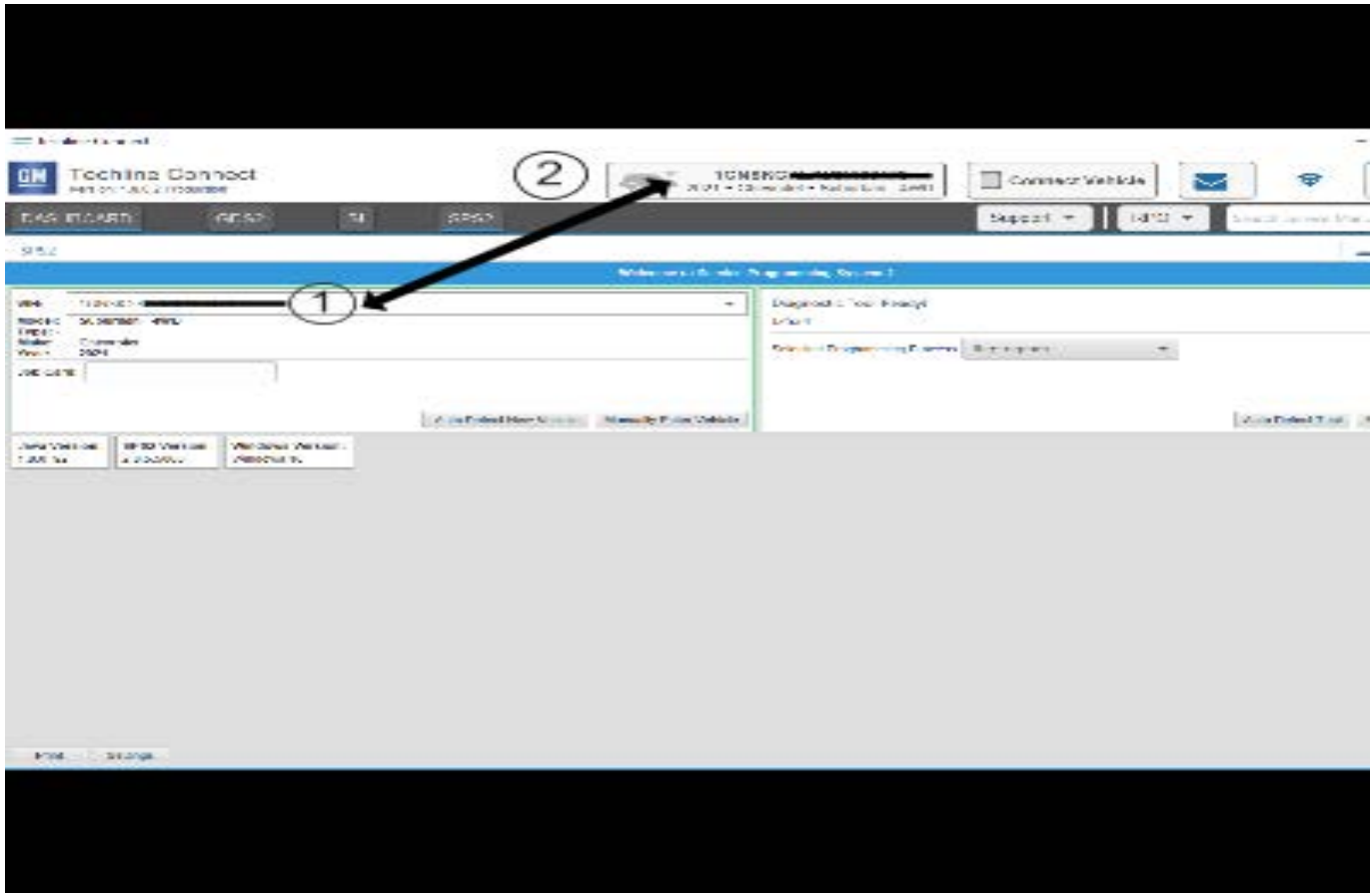

5743643

**Important:** If the vehicle VIN DOES NOT match, the message below will be shown.

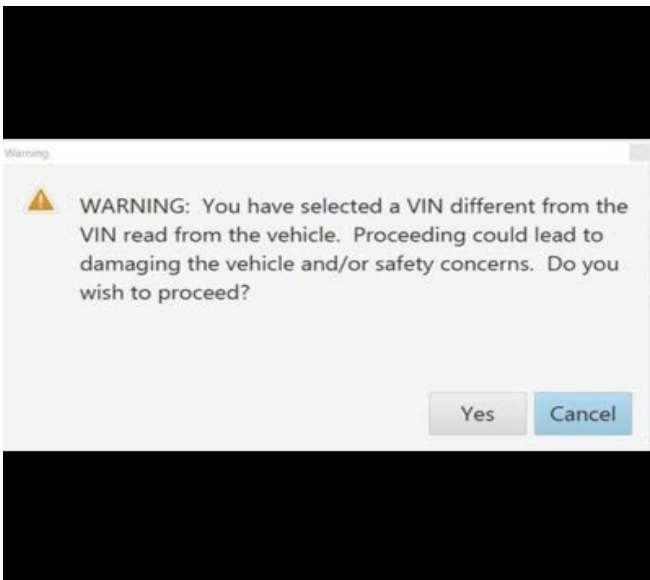

5877000





**Note:** The screenshot above is an example of module programming and may not be indicative of the specific module that is being programmed. Module selection and VIN information have been blacked out.

**Important:** To avoid warranty transaction rejections, you **MUST** record the warranty claim code provided on the Warranty Claim Code (WCC) screen shown above on the job card. Refer to callout 1 above for the location of the WCC on the screen.

2. Record the Warranty Claim Code on the job card for warranty transaction submission.

## Grille Winter Cover Installation

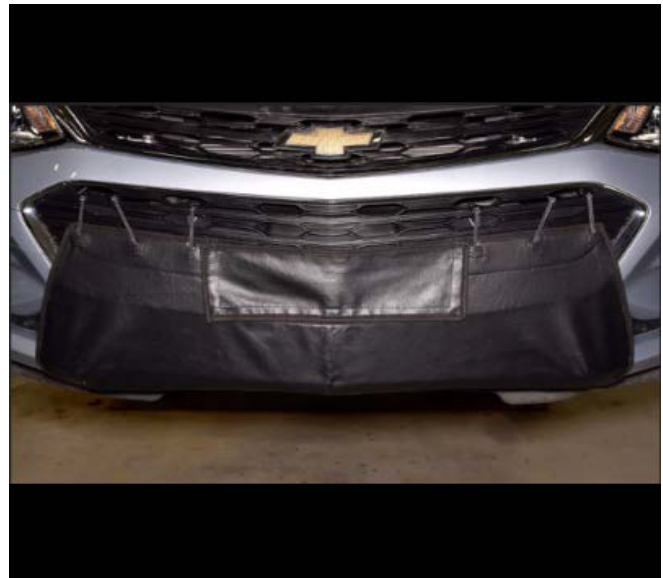

**Warning:** Remove grille cover during temperatures above 32°F/ 0°C to prevent engine and transmission overheating. Remove grille cover before towing a trailer of any size. Failure to do so will decrease transmission cooling efficiency and possibly cause damage to the drivetrain.

5644478

5946388

Install the service winter grille cover around the front bumper to prevent ice-build in the CAC. The installation instructions will be provided with the service part.

### For Vehicles Equipped with RS Package - Grille Cover Modification



6002837

1. Starting at the outer tabs of the grille cover, measure 1 inch from the inside edge of the tab as shown in the graphic above and draw a line.



6002926

2. Utilizing a cutoff tool, cut along the marks.



6002947

3. Dry fit the tabs into the lower fascia molding to ensure proper fit.
4. Proceed to install the grille cover on the vehicle as shown in the Instruction Sheet provided with the part.

### Parts Information

Causal Part	Description	Model Year	Part Number	Qty
N/A	Cover, Grille Winter	2016–2018	42819129	1
N/A		2019	42819130	1
N/A	SHIELD ASM, TCV	All	25205589	1
N/A	Filter, Oil	2016-2019	Refer to the Electronic Parts Catalog (EPC).	
N/A	Oil			

### Warranty Information

**Important:** Warranty coverage code E2 applies for this module programming event. ECM reprogramming is covered for 8 years/80,000 miles (U.S.) or 8 years/130,000 km (Canada).

For vehicles repaired under the Powertrain coverage, use the following labor operation. Reference the Applicable Warranties section of Investigate Vehicle History (IVH) for coverage information.

Labor Operation	Description	Labor Time
4088338*	Charge Air Cooler and IAPT Draining and Cleaning	1.4 hrs
Add	Winter Grille Cover Installation	0.2 hr
Add	Oil Change	0.3 hr
Add	TCV Cleaning and Wrap Install	0.1 hr
2888368**	Engine Control Module Re-programming with SPS for Cruze	0.3 hr

\*This is a unique Labor Operation for bulletin use only.

**Important:** \*\*To avoid warranty transaction rejections, carefully read and follow the instructions below:

- The Warranty Claim Code must be accurately entered in the "SPS Warranty Claim Code" field of the transaction.
- When more than one Warranty Claim Code is generated for a programming event, it is required to document all Warranty Claim Codes in the "Correction" field on the job card. Dealers must also enter one of the codes in the "SPS Warranty Claim Code" field of the transaction, otherwise the transaction will reject. It is best practice to enter the FINAL code provided by SPS/SPS2.

### Warranty Claim Code Information Retrieval

If the SPS Warranty Claim Code was not recorded on the Job Card, the code can be retrieved in the SPS system as follows:

1. Open TLC on the computer used to program the vehicle.
2. Select and start SPS2.
3. Select Settings.
4. Select the Warranty Claim Code tab.

The VIN, Warranty Claim Code and Date/Time will be listed on a roster of recent programming events. If the code is retrievable, dealers should resubmit the transaction making sure to include the code in the SPS Warranty Claim Code field.

<b>Version</b>	4
<b>Modified</b>	Released January 11, 2022 January 14, 2022 – Changed Winter Grille Cover Installation and Oil Change to Add conditions in the Warranty Information section. March 15, 2022 – Updated the Engine Control Module Programming section and added an RS Package Grille Cover Modification section. May 24, 2022 – Updated the Cause, Correction and Service Procedure sections, added Turbocharger Wastegate Regulator Solenoid Valve (TCV) Thermo-Wrap section, added P0234 to first Important under Turbocharger/Supercharger Boost Pressure Sensor Inspection section and updated Parts and Warranty Information.

