



Service Bulletin

Bulletin No.: 21-NA-230

Date: May, 2022

TECHNICAL

Subject: Whining/Whirring, Whistle, Squeaking, Groaning/Growling Noise Coming from Front Wheel/Engine Area

This bulletin replaces PIP5785. Please discard PIP5785.

Brand:	Model:	Model Year:		VIN:		Engine:	Transmission:
		from	to	from	to		
Cadillac	CT6	2016	2020	—	—	—	—

Involved Region or Country	North America
Additional Options (RPO)	CHASSIS DRIVE LINE-ALL WHEEL DRIVE (AWD)/FOUR WHEEL DRIVE (4WD) (RPO F46)
Condition	<p>Some customers may comment on one or more of the following conditions at low speeds during driving maneuvers up to 64 km/h (40 mph):</p> <ul style="list-style-type: none"> • Whining/Whirring • Whistle • Squeaking • Groaning/Growling <p>The customer might state that this noise is coming from the engine/wheel area.</p>
Cause	<p>This condition may be caused by fretting between the Front Intermediate Shaft (IDS Shaft) and the Front Intermediate Shaft Bearing/Housing (IDS bearing).</p> <p>– The fretting is the result of having a slip fit interface between the bearing and the IDS shaft, and combined with a bearing that has around 0.5 N.m of torque to rotate (TTR).</p>
Correction	<p>Perform road test to diagnose fretting noise. Identify if the noise is at the Front Intermediate Shaft Housing. Replace Both the IDS Shaft and IDS Bearing housing.</p> <ol style="list-style-type: none"> 1. Try and replicate the customers concern maneuver (generally the noise is heard while coasting and without brakes being applied). 2. Install Chassis Ears. <ul style="list-style-type: none"> – Identify if the noise is at the Front Intermediate Shaft Housing. 3. Once the noise is confirmed and isolated at the front intermediate shaft housing, replace IDS Shaft and IDS Shaft Housing. Refer to <i>Front Wheel Drive Intermediate Shaft Replacement</i> and <i>Front Wheel Drive Intermediate Shaft Housing Replacement</i> in SI.

Service Procedure

Important: Service agents must comply with all International, Federal, State, Provincial, and/or Local laws applicable to the activities it performs under this bulletin, including but not limited to handling, deploying, preparing, classifying, packaging, marking, labeling, and shipping dangerous goods. In the event of a conflict between the procedures set forth in this bulletin and the laws that apply to your dealership, you must follow those applicable laws.

Important: For proper curing, allow the vehicle to sit overnight (12 hours).

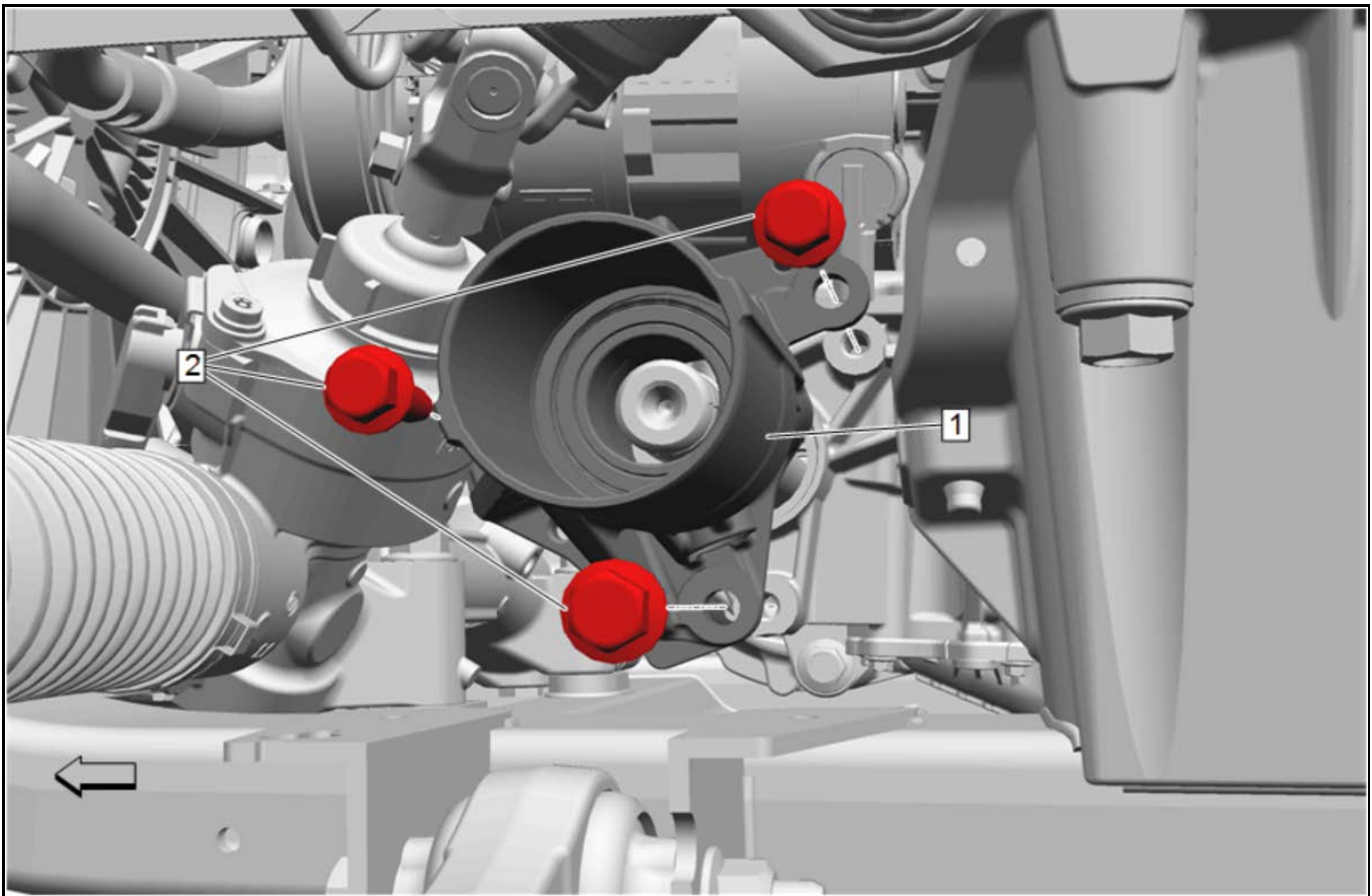

1. Remove the Front Wheel Drive Intermediate Shaft Housing (1). Refer to *Front Wheel Drive Intermediate Shaft Housing Replacement* in SI.

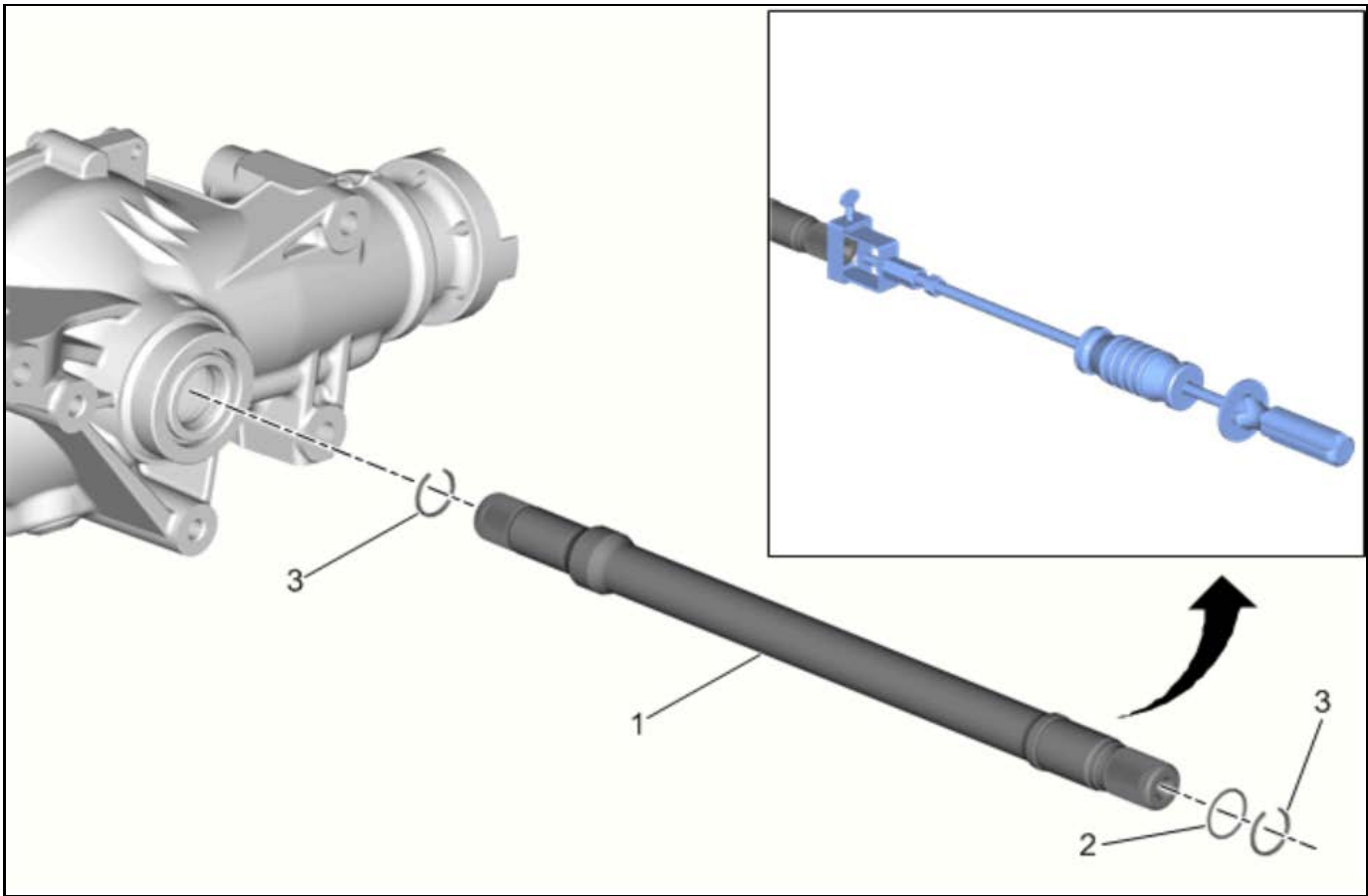

4234084

2. Attach the DT-44467 Output Shaft Assembly Remover/Installer to the shaft (1).
3. Attach the GE-6125-1B Slide Hammer to the DT-44467 Output Shaft Assembly Remover/Installer.
4. Utilizing the tool, remove the Front Wheel Drive Intermediate Shaft from the front differential carrier.

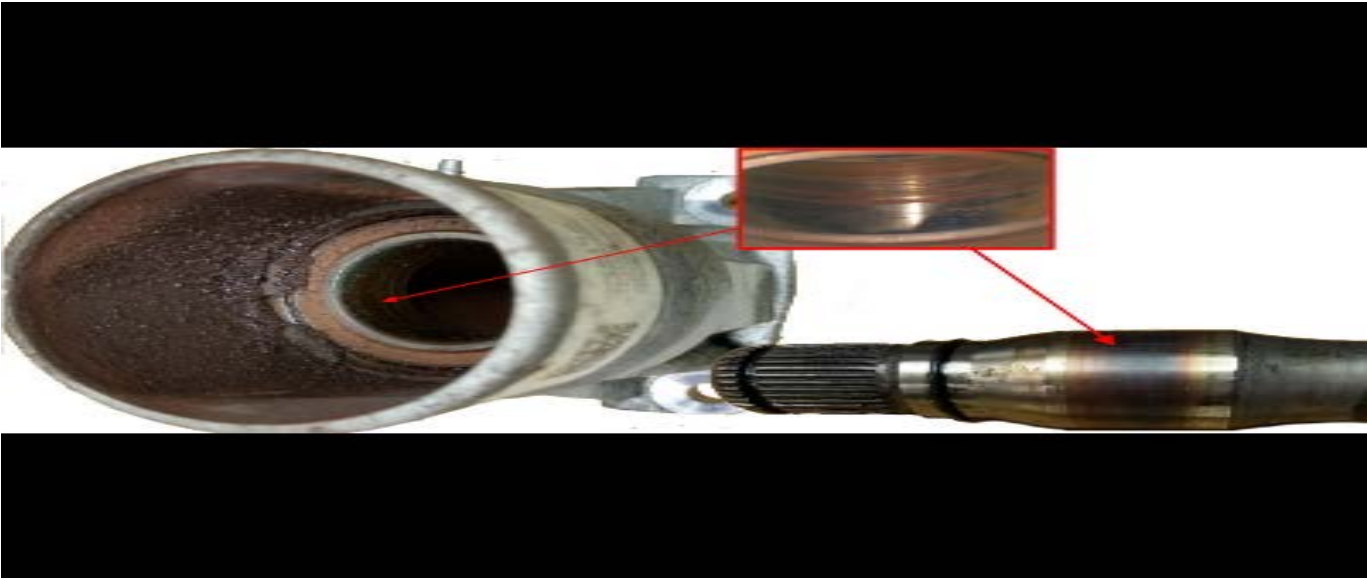

5875997

Note: Fretting worn IDS Shaft and Bracket must be discarded and replaced with new parts. Replace the housing only if damage has been verified.

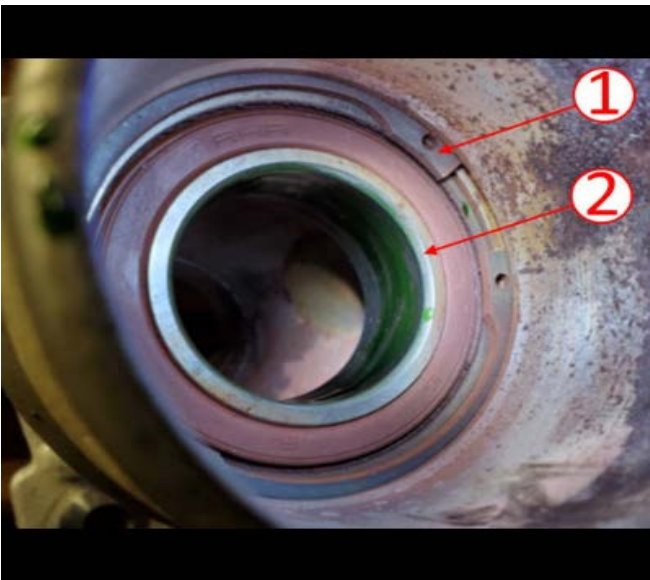

5906520

5. Remove the support bearing snap ring (1).



5906523

6. Using Bearing tool J-06133-A, press the bearing from housing/bracket.
7. Position the new bearing to the housing/bracket.
8. Using Bearing tool J-41736, press the bearing into the housing/bracket until seated.
9. Install the new snap ring.



5902626

Note: For proper curing, allow the vehicle to sit overnight (12 hours).

10. Using High Strength Slip Fit Bonding Compound (P/N 19333514), apply a thin coating to cover the new inner bearing race.

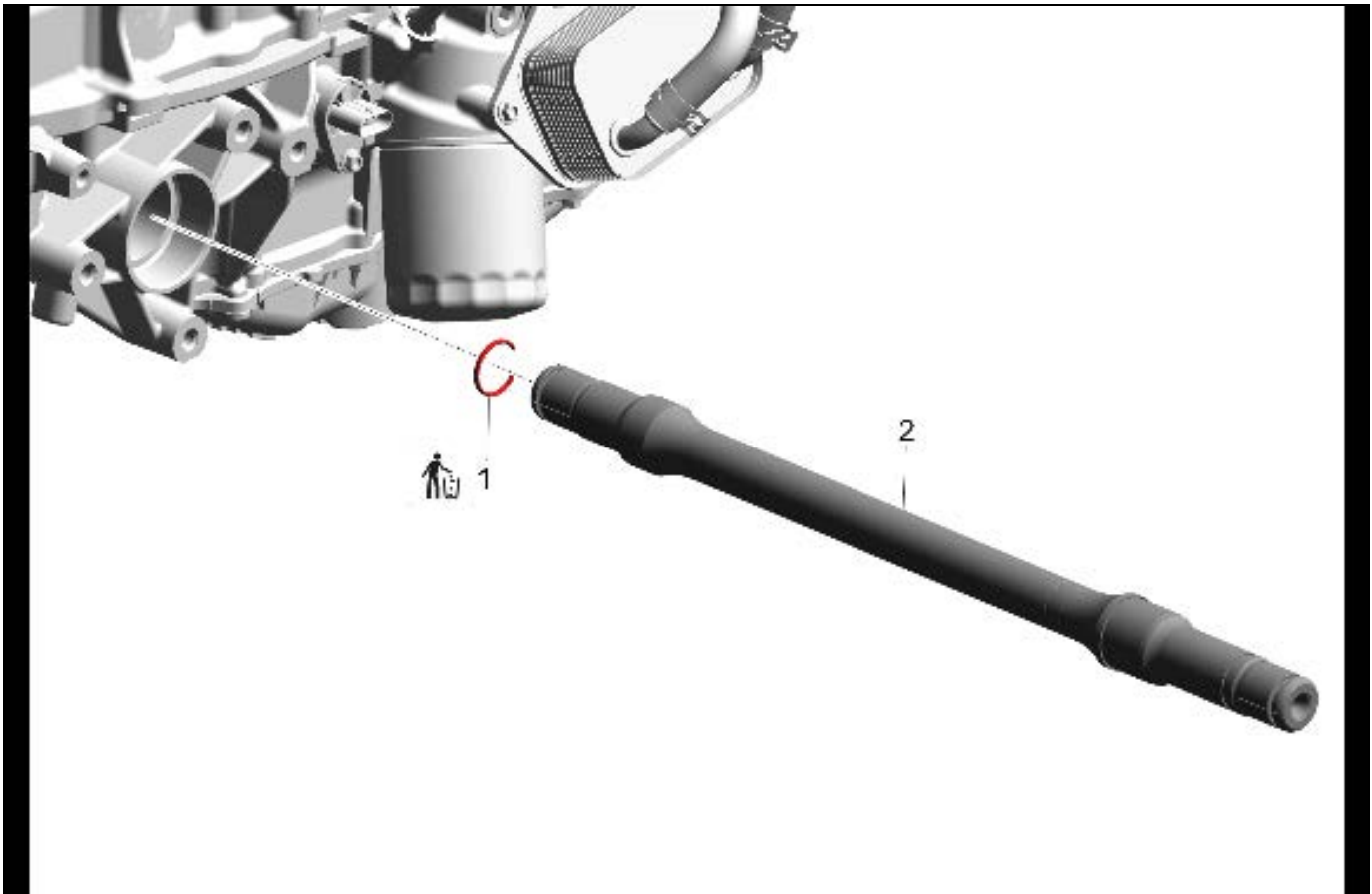

11. Install the New IDS Shaft (2). Refer to *Front Wheel Drive Half Shaft Replacement - Left Side* in SI.

5502695

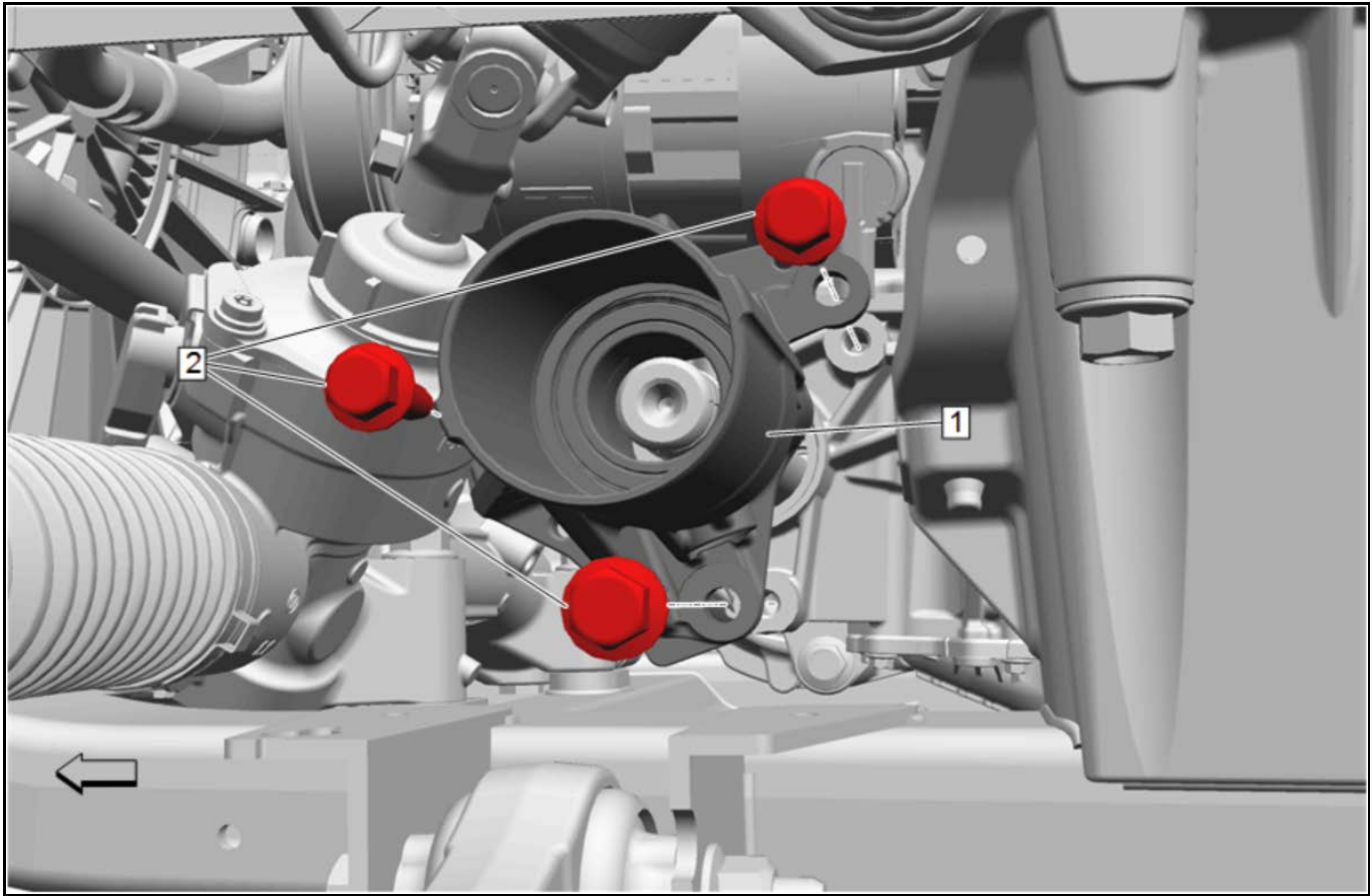

5344068

12. Install the new IDS Housing (1). Refer to *Front Wheel Drive Intermediate Shaft Housing Replacement* in SI.

Tighten

Torque the mounting bolts (2) to 58 N•m (43 lb ft).

Parts Information

Caution: This vehicle is equipped with torque-to-yield or single use fasteners. Install a NEW torque-to-yield or single use fastener when installing this component. Failure to replace the torque-to-yield or single use fastener could cause damage to the vehicle or components.

Note: If the bolts or nuts are found to be damaged or are excessively worn, DO NOT reuse. Replace with new nuts or bolts.

Note: If reusing the propeller shaft bolts, to ensure proper adhesion and fastener retention, the threads must be free of debris prior to the application of thread locker. Use an appropriate cleaner to thoroughly clean the threads and allow to dry. Apply thread locker to the propeller shaft to flange bolts. Ensure that there are no gaps in the thread locker along the length of the filled area of the bolts. Allow the thread locker to cure approximately 10 minutes before installation.

Casual	Description	Engine	Part Number	Qty
N/A	Adhesive, High Strength Slip Fit Bonding Compound	All	19333514 (U.S.) In Canada, use Vibra-Tite® 541 or Loctite® 680™ obtained locally	1
X	Front Intermediate Shaft IDS Shaft	All	23269757	1
X	BRG	All	85587252	1
X	RING, SNP	All	85587253	1

Warranty Information

For vehicles repaired under the Powertrain coverage, use the following labor operation. Reference the Applicable Warranties section of Investigate Vehicle History (IVH) for coverage information.

Labor Operation	Description	Labor Time
3087188*	Diagnostic Test and drive	0.5 hr
Add	Replace Front Wheel Drive Intermediate Shaft, Bearing , and Apply GM Adhesive (Base)	1.6 hrs
*This is a unique Labor Operation for bulletin use only.		

Version	2
Modified	Released February 01, 2022 May 25, 2022 – Added Important statement at beginning of Service Procedure and changed Adhesive, High Strength Slip Fit Bonding Compound Part Number for Canada to obtain locally.

