



TECHNICAL SERVICES INFORMATION BULLETIN

TSIB 22-04 Rev A		April 13, 2022
TO:	All Operators	
TITLE:	Front Junction Box Cover Retrofit	
APPLICABILITY:	All MCI J4500, J3500, D45CRTLE and D4520 coaches equipped with Power Distribution Panel (PDP) in front junction box	

WARNING

Read this entire procedure before beginning work.

Use Safe Shop Practices at All Times.

To avoid personal injury:

- a. Proper Personal Protective Equipment (PPE) must be worn. Safety glasses and protective gloves are required for working with DEF Fluid.*
- b. Turn the main battery disconnect switch to the OFF position.*
- c. Ensure that both the front and the rear wheels are chocked.*
- d. Position the ENGINE RUN and ENGINE START switches on the engine compartment remote control box to the OFF position.*
- e. Allow enough time for components to cool down prior to working in the engine compartment.*

1.0 Description

This TSIB is issued to address the issue of water ingress into the front junction box area from the door. Follow the steps in this TSIB to install a cover that protects the circuits on the front junction box panel from water ingress.

2.0 Material Requirements

Item	Part Number	QTY	U/M	Description
1	959749	1	EA	Cover-Front Junction Box
2	959998	1	EA	Trim Lock w/ bulb seal
3	960199	6	EA	Bracket-FJB cover
4	19-1-655	3	EA	Screw - Pan Head, 10-24 X ½
5	117202	2	FT	Tubing-Heatshrink .75BL

3.0 Special Tools

N/A

4.0 Rework Instructions

Open front junction box door.



Remove and save the three screws securing the panel on top of the front junction box area.

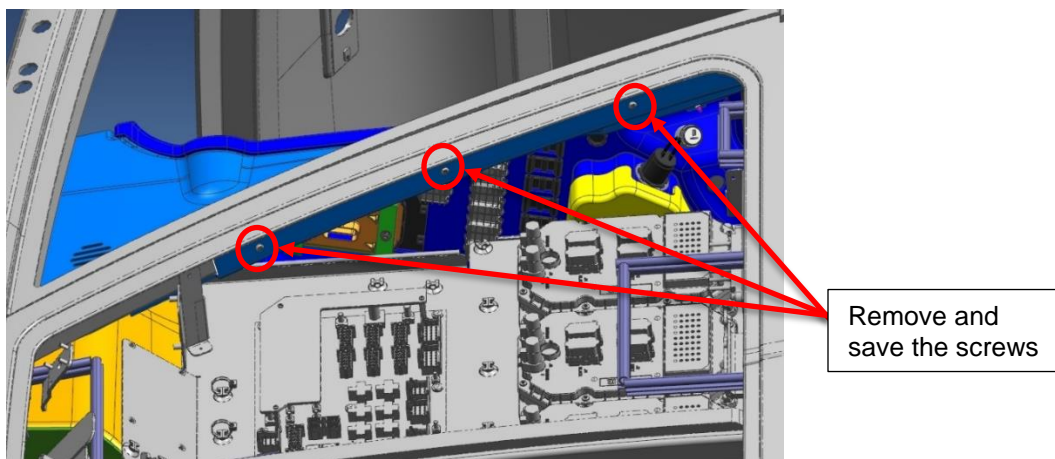

Install heat shrink, MCI P/N: 117202, on all six brackets, MCI P/N: 960199, as shown below.

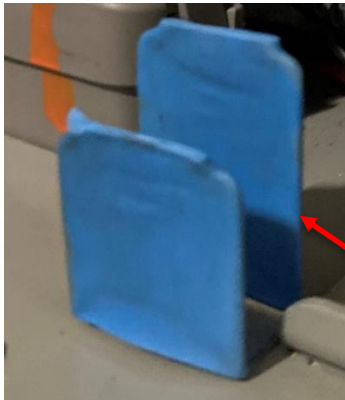

Install heat shrink on the brackets

Install three brackets, MCI P/N: 960199, at the three holes using existing screws such that the longer face of the bracket is towards the back of the front junction box.

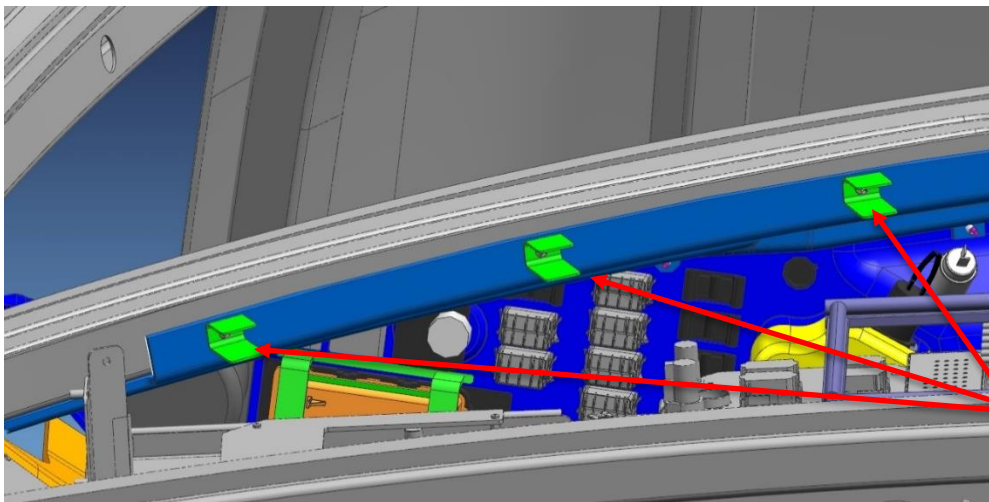

Install brackets, 960199, using existing screws

Mark three locations on the bottom of the front junction box panel at the dimensions shown below.

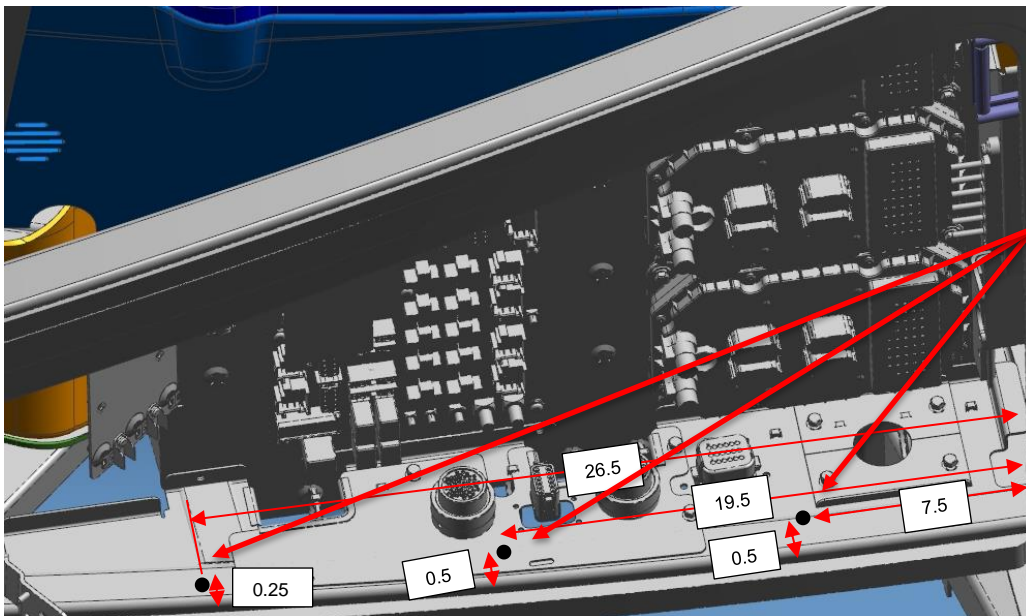

Mark three holes

Install three brackets, MCI P/N: 960199, at the three marked locations using tapping screws, MCI P/N: 19-1-655, such that the taller face of the bracket is facing towards the front junction box.



Install brackets, 960199, using 19-1-655 screws

Install bulb seal, MCI P/N: 959998, around the top, bottom and cutout edges of the cover, MCI P/N: 959749.

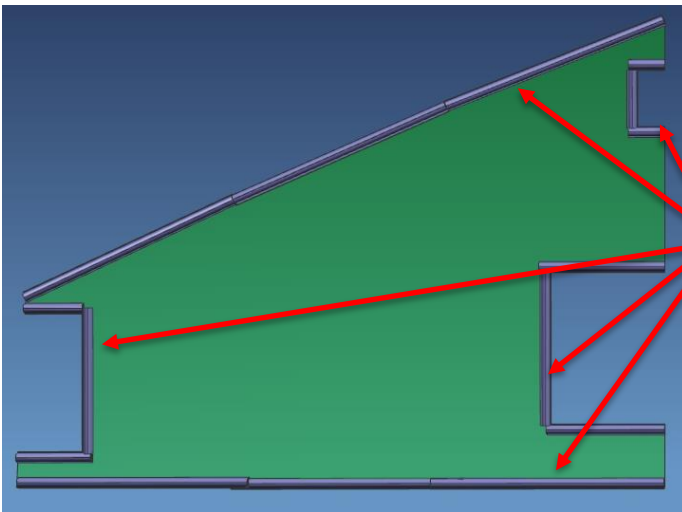

Install trimlock w/ bulb seal around the panel

Slide the modified cover into the brackets to seal the FJB.

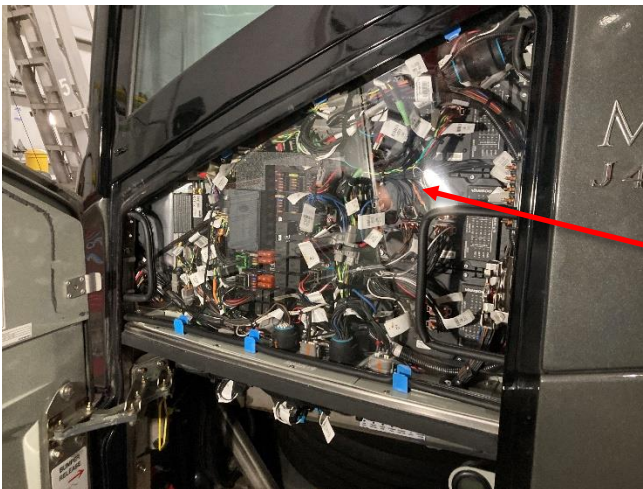

Slide the modified cover in the brackets

If you have questions or need further assistance, please contact MCI Technical Call Center @ 1-800-241-2947.