



# Service Bulletin

Bulletin No.: 20-NA-142

Date: May, 2022

## TECHNICAL

**Subject:** Shudder/Surging While Driving

**Attention:** This bulletin only applies to vehicles with 50,000 km (30,000 miles) or less. For vehicles with over 50,000 km (30,000 miles), the torque converter and transmission oil filter should be replaced following published Service Information.

Brand:	Model:	Model Year:		VIN:		Engine:	Transmission:
		from	to	from	to		
Chevrolet	Express	2015	2022				MYC, MYD
	Suburban		2018				
	Silverado	2019					
	Silverado LD		2019				
	Silverado 2500/3500	2022					
	Silverado 1500 (New Model)	2019	2021				
	Silverado 1500 - LTD (RPO J21, VIN Digit 12 = 4 or less)	2022	2022				
	Silverado 1500 - New (RPO J22, VIN Digit 12 = 5 or greater)						
	Tahoe	2015	2022				
GMC	Savana	2015	2022				
	Sierra		2018				
	Sierra Limited	2019	2019				
	Sierra 2500/3500		2022				
	Sierra 1500 (New Model)	2019	2021				
	Sierra 1500 - Limited (RPO J21, VIN Digit 12 = 4 or less)	2022	2022				
	Sierra 1500 - New (RPO J22, VIN Digit 12 = 5 or greater)						
	Yukon	2015	2022				

<b>Involved Region or Country</b>	North America, Russia, Middle East, Israel, Palestine, Chile, Columbia, Ecuador, Paraguay, Peru and Thailand.
<b>Condition</b>	Some customers may comment that a surging condition is felt when driving. Some technicians may find while performing Torque Converter Diagnosis per Service Information, may identify the surging as a torque converter shudder condition.
<b>Cause</b>	This condition may be caused by additives in the transmission fluid may have been depleted during vehicle operation. – Some of these additives assisted with regulating a consistent slip rate of the clutches.

## Correction

**Note:** This bulletin should only be used on vehicles with 50,000 km (30,000 miles) or less. For vehicles with over 50,000 km (30,000 miles) the torque converter and transmission oil filter should be replaced following published Service Information.

1. Raise the vehicle.
2. Remove the transmission pan.



5360216

- If metallic debris is present (similar to graphic above), remove transmission and replace the torque converter and replace the transmission filter. Refer to *Torque Converter Replacement in SI*.
  - If metallic debris is not present drain and clean the oil pan and reinstall transmission oil pan.
3. Fill the transmission with 6 quarts of DEXRON VI Transmission Fluid following published Service Information.
  4. Lower the vehicle to a safe level on the hoist and operate the transmission through all 6 gear forward ranges, reverse and neutral.
  5. Remove transmission oil pan and drain, reinstall the oil pan.
  6. Fill the transmission with 6 quarts of DEXRON VI Transmission Fluid following published Service Information.
  7. Lower the vehicle to a safe level on the hoist and operate the transmission through all 6 gear forward ranges, reverse and neutral.
  8. Remove transmission oil pan and drain, clean pan and replace the transmission filter.
  9. Fill the transmission with 6 quarts of DEXRON VI Transmission Fluid.
  10. Set the fluid level following published Service Information.

## Service Procedure

### Vehicles Equipped with a Fluid Fill Tube

**Note:** Refer to TSB 21-NA-199 to verify in the Thermal Bypass Valve (TBV) requires updating.

1. Remove the transmission Thermal Bypass Valve (TBV) and or cooler lines.
2. Install DT-53040 Adapter, Trans Flushing Tool to the cooler line ports on the transmission reusing the existing cooler line seal.
3. Place the drain hose from DT-53040 into GE-47716-2 Graduated Bucket.
4. Lower the vehicle.
5. Through the transmission fluid fill tube add 6 quarts of DEX VI Transmission fluid.
6. Start the engine and drain 4 quarts of transmission fluid into the GE-47716-2 Graduated Bucket then shut the engine off immediately.
7. Through the transmission fluid fill tube add 4 quarts of DEX VI Transmission fluid.
8. Start the engine and drain 4 quarts of transmission fluid into GE-47716-2 Graduated Bucket then shut the engine off immediately.
9. Through the transmission fluid fill tube add 4 quarts of DEX VI Transmission fluid
10. Raise the vehicle, remove the DT-53040 and reinstall the Thermal Bypass Valve (TBV) and or cooler lines installing a new Cooler Line Seal.
11. Tighten the bolt (2) to 22 nm (16 lb ft).

12. Lower the vehicle.
13. Set the fluid level to the proper level following Service Information.

### Initial TransFlow Flush Machine Shop

**Important:** The prepping procedure only needs to be completed if the DT-45096 supply reservoir does not have DEX VI fluid in it.

1. Connect the TransFlow adapter DT-45096-31 to the supply line of the DT-45096 TransFlow machine.



5180884

2. Switch the DT-45096 TransFlow to Idle.
3. Connect power leads to the vehicle 12-volt DC supply.
4. Turn the TransFlow main switch ON.
5. Connect air supply to the DT-45096.
6. Place the TransFlow supply hose with adapter DT-45096-31 into a waste reservoir using care not to spill the expelled fluid.
7. Switch the DT-45096 TransFlow to Flow and allow all the fluid in the supply reservoir to be removed and placed in the waste reservoir.
8. Switch the control switch back to idle.

### Fluid Exchange Procedure

1. Fill the DT-45096 with 17 quarts of DEX VI fluid.
2. Raise the vehicle on a hoist.

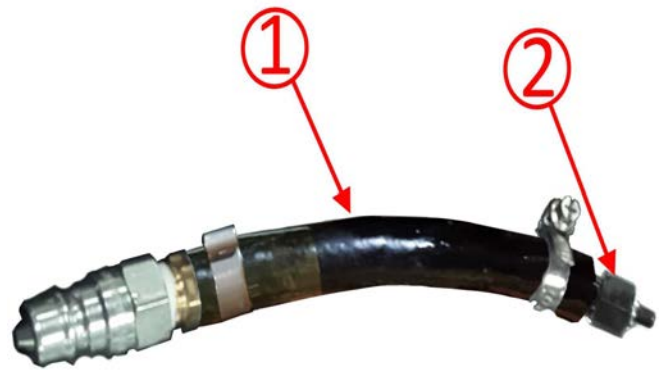

5182541

3. Install the DT-45096-31 TransFlow adapter (1) to the DT-51190 fluid fill adapter (2).
4. Remove the transmission oil thermal bypass valve/cooler pipe assembly from the transmission.
5. Install the DT-53040 Adapter Block Assembly to the transmission, reusing the seal from the transmission oil cooler pipe assembly.
6. Tighten the bolt (2) to 22 nm (16 lb ft).



5181401

7. Place the hose in the GE-47716-2 Graduated Measuring Bucket, utilizing a Spring Clamp to retain the hose.
8. Remove the level set plug from the transmission.

**Important: DO NOT** over tighten the DT-51190 as it can be damaged by excessive torque. **DO NOT** exceed 9 Y (80 lb in).

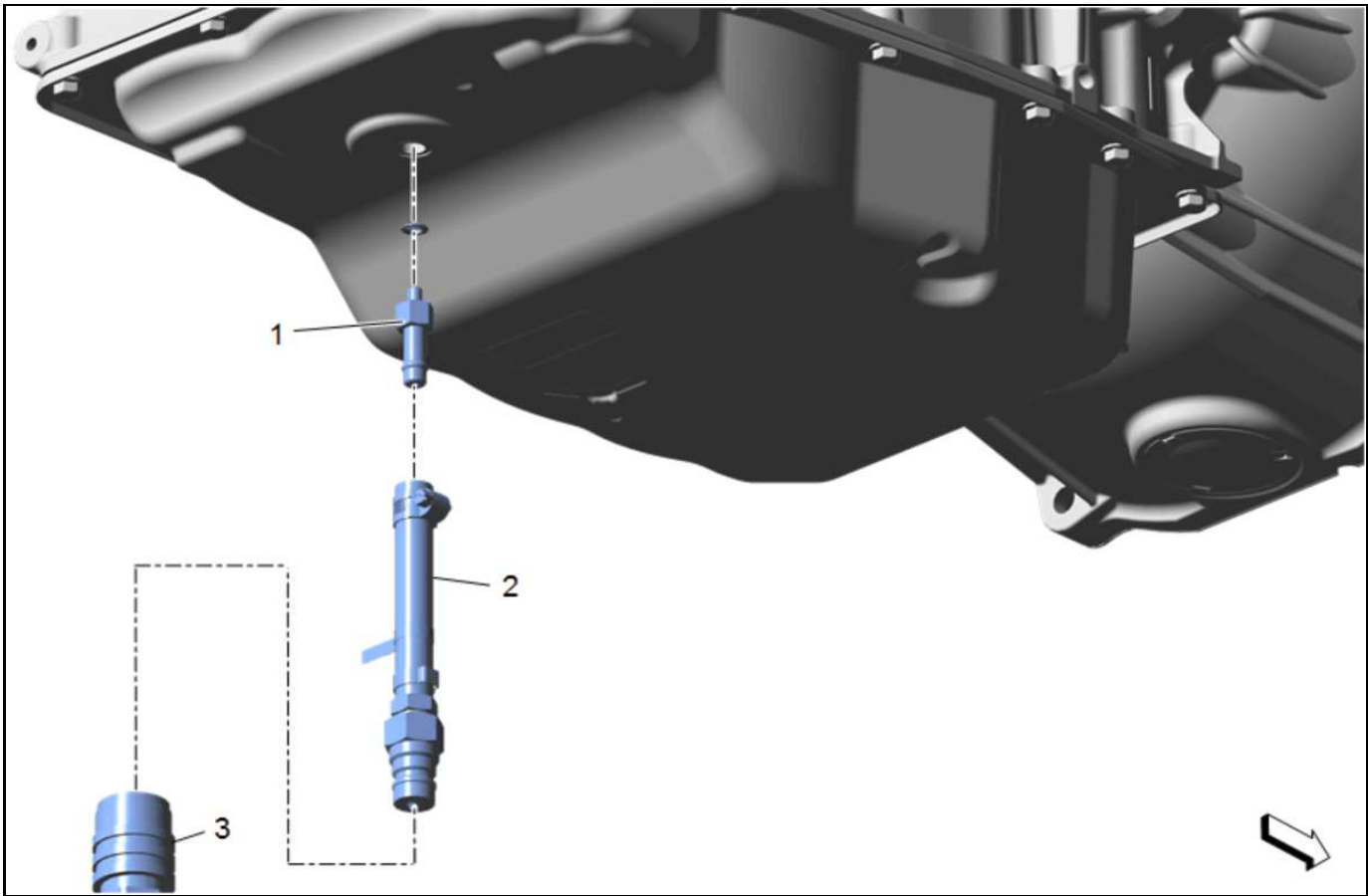

9. Install the DT-51190/DT-45096-31 assembly and hand tighten as shown in the graphic above.
10. Connect the TransFlow fluid feed (supply) line (3) to the DT-45096-31 adapter.
11. Lower the vehicle.
12. Connect the DT-45096 to the vehicle battery 12 volts and connect shop air to the air connection.

5122324

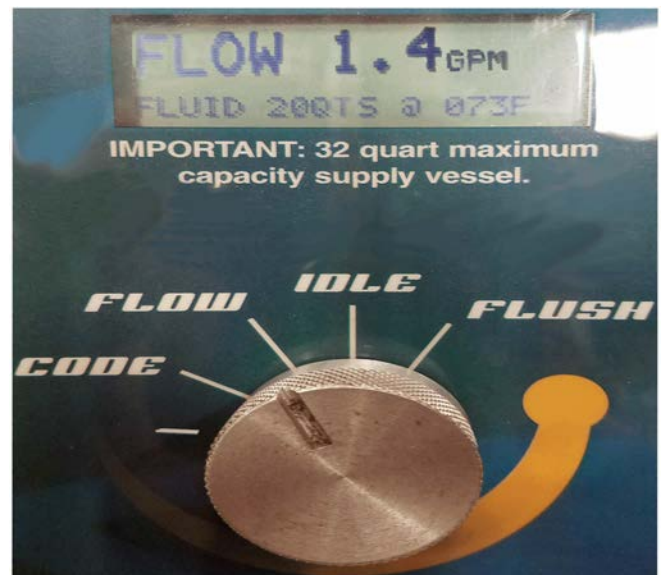

5181027

13. Switch the DT-45096 TransFlow to Flow and add 6 quarts of DEX VI to the transmission. (Reducing fluid level in the TransFlow from 17–11).
14. Switch the TransFlow to Idle.

15. Utilizing the graduated bucket, start the engine and run 30- 45 seconds until 4 quarts of fluid is expelled.
  16. Shut the engine off immediately.
  17. Switch the DT-45096 TransFlow to Flow and add 4 quarts of HP to the transmission (Reducing fluid level in the TransFlow from 11–7).
  18. Switch the DT-45096 TransFlow to Idle.
  19. Utilizing the graduated bucket, start the engine and run 30- 45 seconds until 4 quarts of fluid is expelled.
  20. Switch the DT-45096 TransFlow to Flow (Reducing fluid level in the TransFlow from 7–2).
  21. Shut the engine off.
  22. Raise the vehicle.
  23. Disconnect the DT-45096 TransFlow feed (supply) line from the DT-45096-31.
  24. Using care, remove DT-45096-31/DT-51190 as an assembly.
  26. Tighten the bolt (2) to 22 nm (16 lb ft).
- Note:** Review TSB 21-NA-199 to see the Thermal Bypass Valve (TBV) needs to be updated.
27. Install the level set plug. Tighten the plug to 9 nm (80 lb in).
  28. Remove the DT-53040 Adapter and install the Thermal Bypass Valve/Cooler Line Set using a new seal.
  29. Lower the vehicle leaving the wheels off the ground. Start and run the engine through all forward gears and reverse.

30. Set the fluid level following published Service Information procedures.

### Parts Information

Causal Part	Description	Part Number	Qty
N/A	Drum, 55 Gallon (U.S.)	19293024/ 19420008 (Available through local GM Oil Distributor)	As Required
N/A	Drum, 208 Liter (Canada)	19420144	
N/A	3 - 4.73 Liter Containers (Canada)	19420143	
N/A	6 - 1 Liter Containers (Canada)	19420142	
N/A	1 Qt (U.S.)	88864060/ 19421240 (Available through local GM Oil Distributor), 88865601 (GM CCA Stock Order)	
N/A	Kit, Filter	24236933	
N/A	Seal, Trans Fluid Cooler Piper Fitting	23135703	1

### Warranty Information

For vehicles repaired under the Powertrain coverage, use the following labor operation. Reference the Applicable Warranties section of Investigate Vehicle History (IVH) for coverage information.

Labor Operation	Description	Labor Time
8481018*	Automatic Transmission Fluid, Fluid Pan and/or Filter Replacement	1.2 hr
Add	Fluid Exchange Procedure for Vehicles Equipped with a Fluid Fill Tube	0.6 hr
Add	2019 – 2022 Silverado 1500/Sierra 1500 (New Body Style T1XX) Pan Removal, Inspection and Filter Replacement	1.5 hr
Add	Fluid Exchange Procedure for 2019 – 2022 Silverado 1500/ Sierra 1500 (Not Equipped with a Fluid Fill Tube)	1.0 hr

\*This is a unique Labor Operation for Bulletin use only.

Version	9
Modified	<p>Released July 06, 2020</p> <p>Revised July 20, 2020 - Update Parts Information Section.</p> <p>Revised September 08, 2020 - Removed the 1 gallon p/n 88865765 from the Parts Information section.</p> <p>Revised October 15, 2020 - Added 2020 to Model Year.</p> <p>Revised November 19, 2020 - Added Tahoe to Models section, changed 2 part #'s and added regions.</p> <p>Revised January 11, 2021 - Update U.S. part numbers in the Parts Information section.</p> <p>Revised February 09, 2021 - Updated Procedure in Correction section, Removed Service Procedure section and Updated Labor Operation Time.</p> <p>Revised September 13, 2021 - Added Attention statement, Note to Correction section and Removed Reference to PIP5504F from Condition section.</p> <p>Revised May 18, 2022 - Added 2021–2022 to Model Years, Added Service Procedure section, Added Pipe Seal to Parts section and Updated Warranty Information section.</p>

