



RECALL ACTION

Global Recall Action
Number: N685

Subject: Front Impact Sensor Torque Check	Publication No.: N685
	Model: Range Rover (LK)
	Model Year: 2022
	Date of Issue: 20 May 2022

To:	Jaguar Land Rover (JLR) North America, LLC - USA only
For the Attention of:	The approved JLR retailer/authorized repairer
Related Information:	NOTE: The information in this campaign is intended for use by trained, professional technicians with the knowledge, tools, and equipment required to do the job properly and safely. It informs these technicians of conditions that may occur on some vehicles or provides information that could assist in proper vehicle service. The procedures should not be performed by 'do-it-yourselfers'. If you are not a JLR retailer/authorized repairer, do not assume that a condition described affects your vehicle. Contact an authorized JLR retailer/authorized repairer to determine if this campaign applies to a specific vehicle

DESCRIPTION OF ISSUE AND THE EFFECT ON VEHICLE OPERATION

2022 model year New Range Rover vehicles

A potential concern has been identified on specific vehicles within the above vehicle range.

A concern has been identified on certain 2022 model year New Range Rover vehicles where the front crash sensor fixings may not have been installed to the specified level of torque. There is a risk that the front crash sensors may become loose resulting in incorrect operation of the active restraints system. This could lead to increased occupant injury or, in the case of inadvertent frontal airbag deployment, loss of vehicle control increasing the risk of a crash.

REGULATORY INFORMATION

JLR North America, LLC have informed the National Highway Traffic Safety Administration (NHTSA) of their intent to perform a Safety Recall on certain 2022 model year New Range Rover vehicles imported into the United States. Information relating to this Safety Recall will be posted on the NHTSA website. United States Federal regulations require that retailers/authorized repairers must be notified within a reasonable time after the manufacturer decides that a defect that relates to motor vehicle safety or a non-compliance exists. United States Federal Law requires retailers/authorized repairers to complete any outstanding Safety Recall before a new vehicle is delivered to the buyer or lessee. Violation of this requirement by a retailer/authorized repairer could result in a maximum civil penalty of up to \$22,992.00 USD per violation and up to \$114,954,525.00 USD for a related series of violations. This Safety Recall serves as notification to all retailers/authorized repairers in the United States and Federalized Territories that any affected new vehicles may not be sold and delivered for customer use until the Safety Recall is completed.

JLR North America, LLC recommends that affected sales demonstrator and loaner vehicles are repaired before use, and that used vehicles are repaired before sale. Retailers/authorized repairers who choose to proceed against this recommendation, where legally permitted, must clearly and conspicuously disclose the open Safety Recall notice to the applicable customers.

This Safety Recall notice serves as notification to all JLR retailers/authorized repairers that any affected new vehicles may not be sold and delivered for customer use until the Safety Recall repair is completed.

ACTION TO BE TAKEN

JLR has taken the decision to recall affected vehicles to repair the vehicle.

Visit the British Brands Sales Suite (BBSS) website for a list of affected vehicles at your retailer/authorized repairer.

Following procedures appropriate to your market and as required by local legislation, owners of affected vehicles should be contacted requesting that the owner contact their nearest retailer/authorized repairer as soon as possible to arrange for the repair to be completed. The National Sales Companies (NSCs), Importer, Regional Office or Government agency will contact the customers. If you have any questions about this process, please contact your NSC/Importer or Regional Office for more information.

An owner may indicate that a repair has already been completed for this concern, in which case the full cost of the repair should be reimbursed. Refer to the warranty section of this Safety Recall for details of the reimbursement process. At the time of confirming a booking for a vehicle repair, make sure you check the JLR claims submission system and that all other outstanding campaigns are identified to make sure the correct parts are available and adequate workshop time is allocated for repairs to be completed in one visit.

Check the JLR Warranty Portal to make sure affected vehicles are correctly identified prior to starting this campaign. The Warranty Portal will be updated to reflect only those vehicles affected.

For information purposes, a Technical Question and Answer document is attached.

5/20/22, 9:08 AM

Front Impact Sensor Torque Check

Yours faithfully

Simon Barnes

Global Customer Service Quality Director

SERVICE INSTRUCTION - N685



NOTE: The information in this campaign is intended for use by trained, professional technicians with the knowledge, tools, and equipment required to do the job properly and safely. It informs these technicians of conditions that may occur on some vehicles or provides information that could assist in proper vehicle service. The procedures should not be performed by 'do-it-yourselfers'. If you are not a Jaguar Land Rover (JLR) retailer/authorized repairer, do not assume that a condition described affects your vehicle. Contact an authorized [JLR](#) retailer/authorized repairer to determine if this campaign applies to a specific vehicle.

SROs

Description	SRO	Time
Front impact sensors - Apply torque	05.10.10	0.1
Drive in/drive out	02.02.02	0.2



NOTE: Repair procedures are under constant review, and therefore times are subject to change; those quoted here must be taken as guidance only. Always refer to TOPIx to obtain the latest repair time.

Warranty Information

Warranty claims should be submitted quoting program code N685 with the relevant option code from the table below. As option codes are used there is no requirement for you to enter SROs or parts, these are included for information only.

Program Code	Option	Description	SRO	Time
N685	A	Front impact sensors - Apply torque	05.10.10	0.1
N685	B	Front impact sensors - Apply torque Drive in/drive out	05.10.10 02.02.02	0.1 0.2



NOTE: The option that contains the drive in/drive out allowance may only be claimed when the vehicle has been brought back into the workshop for this action alone to be undertaken.

Warranty claims should be submitted in accordance with the current [JLR](#) Global Warranty Manual, and its amendments, unless stated otherwise in this bulletin.

Customer Reimbursement and Related Damage Process



NOTE: If there is a requirement to claim for related/consequential damage or customer reimbursement, refer to the related instruction that can be found in TOPIx (in the Search box search for 'Related Damage Claim' and open the related bulletin link).

SERVICE INSTRUCTION

NOTES:



Some components are shown removed from the vehicle, to provide extra clarity.



Some variation in illustrations may occur, but the essential information is always correct.



3.0L AJ20-D6 shown, 3.0L AJ20-P6 and 4.4L NC10 are similar.

1. Open the hood.

2. Locate and torque the 2 impact sensor bolts.

- Torque: **10 Nm**

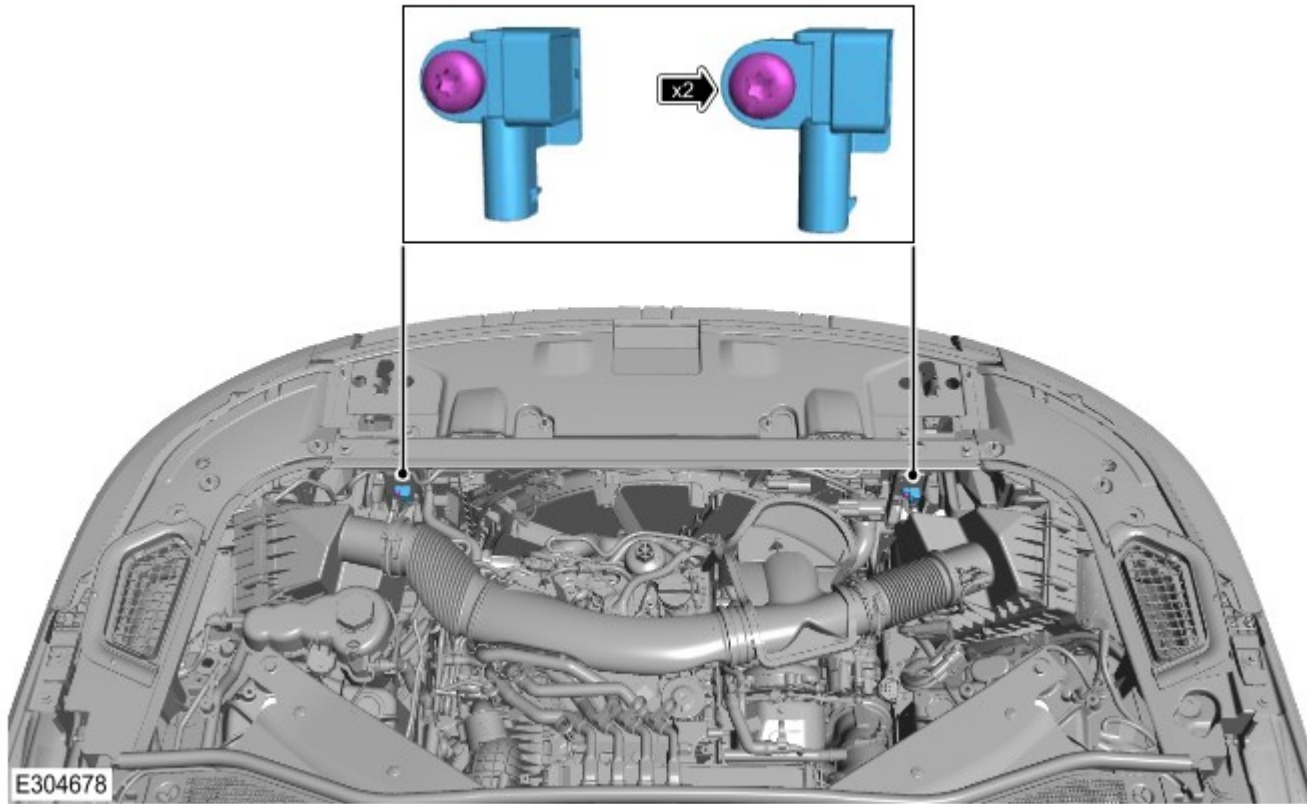

3. Close the hood.

SAMPLE CUSTOMER LETTER - FOR INFORMATION ONLY

Name
Address line 1
Address line 2
Address line 3
Post Code

Vehicle Identification Number (VIN):
Registration Number:
Program Number: N685

Date: month/year

SAFETY RELATED RECALL - New Range Rover vehicles - Front Impact Sensor Torque Check

Dear

Jaguar Land Rover Limited would like to advise you that during ongoing quality assessment of our product it has been identified that a possible safety related problem may occur on certain 2022 model year New Range Rover vehicles. Please read the information below, this will explain the actions that we intend to take and what you will need to do. Please read the information below, this will explain the actions that we intend to take and what you will need to do.

Why are we contacting you?

We have found that the front crash sensor fixings on your vehicle may not have been installed to the specified level of torque. There is a risk that the front crash sensors may become loose resulting in incorrect operation of the active restraints system. This could lead to increased occupant injury or, in the case of inadvertent frontal airbag deployment, loss of vehicle control increasing the risk of a crash.

What will your Land Rover retailer/authorized repairer do?

We will tighten the front crash sensor fastener to the specified level of torque.

How long will it take?

The work on your vehicle will be completed as quickly and efficiently as possible in order to minimize inconvenience to you. Your retailer/authorized repairer will be able to advise how long your vehicle will be required for when a booking is made.

What we are asking you to do

Please contact your preferred Land Rover retailer/authorized repairer without delay. To book your vehicle in for this action you will need to provide the retailer/authorized repairer with the following which are detailed at the beginning of this letter:

- The VIN for your vehicle
- Vehicle registration number of your vehicle.
- The program code for the action.

If you do not have a retailer/authorized repairer, please access www.landrover.co.uk or www.landrover.com for contact details.

If you no longer own the vehicle could you please complete the 'Change of Ownership' slip attached to this letter, returning the slip to Jaguar Land Rover Limited immediately in the enclosed 'Freepost' envelope. This will enable us to make contact with the new owner.

If you have concerns

If you experience any concerns relating to this Recall, contact the Service Manager at the retailer/authorized repairer for assistance or contact the JLR Limited Customer Experience Centre on 0345 303 2303 or (enter phone number).

This bulletin is being issued in accordance with the legislative or industry requirements concerning vehicle defects. The authorities will closely monitor the response rate of this bulletin.

Please treat this matter with the urgency it requires, JLR Limited apologize for any inconvenience this bulletin may cause and thank you, in advance, for your co-operation.

Yours sincerely

Head of Business

Technical Questions And Answers	
FOR USE ON ENQUIRY	
Jaguar Land Rover Safety Recall N685	
Certain 2022 model year New Range Rover vehicles, Inadequate fixing torque of the front crash sensors	

A concern has been identified on certain 2022 model year New Range Rover vehicles where the front crash sensor fixings may not have been installed to the specified level of torque. There is a risk that the front crash sensors may become loose resulting in incorrect operation of the supplementary restraints system.

Question 1

Who do I contact if a member of the press contacts me about this recall?

Answer

Make sure that any press enquiries are referred to the Jaguar Land Rover (JLR) Corporate Affairs office.

Question 2

Why is JLR Limited recalling these vehicles?

Answer

Should the crash sensors be incorrectly installed where the fixings are not torqued to the specification required, they may become loose resulting in incorrect operation of the active restraints system. This could lead to increased occupant injury or, in the case of inadvertent frontal airbag deployment, loss of vehicle control increasing the risk of a crash.

Question 3

Can you tell me more about what is wrong with the vehicles?

Answer

The investigation conducted revealed a manual error was made during the assembly of some vehicles where the fixings were only partially fixed (by hand only) and the manufacturing operation was not completed. The error was found to be human error.

Question 4

How would the customer become aware of their vehicle potentially having this concern?

Answer

It is unlikely there will be any indication of a problem.

Question 5

Does this concern affect vehicle safety?

Answer

Yes. This could lead to increased occupant injury or, in the case of inadvertent frontal airbag deployment, loss of vehicle control increasing the risk of a crash.

Question 6

Has JLR received many complaints?

Answer

No. This matter was found through internal vehicle quality assessments.

Question 7

Have there been any accidents or injuries or fires?

Answer

There are no accidents, injuries or fires known to be related to this issue.

Question 8

How was the concern discovered?

Answer

Part of the routine vehicle inspections completed as part of new model introduction found this issue.

Question 9

How long has JLR known about this concern?

Answer

The issue was recognized on 5th April 2022.

Question 10

Is the defect leading you to any concerns regarding the reliability of a system, which is supposed to be designed and engineered for the passengers' safety? What type of measures are you planning to take?

Answer

JLR has no concerns with the overall reliability of the vehicle. JLR carefully monitors field data to make sure that any matters relating to safety and compliance are rigorously investigated.

Question 11

What has JLR done in production?

Answer

The production processes involved have been reviewed to make sure that these fixings are installed correctly.

Question 12

What will retailer/authorized repairers do to the vehicles?

Answer

Owners will be notified and instructed to take their vehicle to a Land Rover approved retailer/repairer, who will make sure that the fixings are correctly torqued. There will be no charge to owners for this repair.

Question 13

Which vehicles are affected by this recall?

Answer

New Range Rover 2022 model year

Manufactured from February 2nd 2022 to February 22nd 2022.

Question 14

Are other JLR models affected by this concern?

Answer

No, no other vehicles are affected by this concern.

Question 15

Is the repair available to rework vehicles?

Answer

Yes.

Question 16

How much will the recall cost JLR?

Answer

Cost was not a factor in deciding to recall these vehicles.

Question 17

How do I know if my vehicle is affected?

Answer

Where possible, owners of potentially affected vehicles will shortly receive a letter inviting them to contact a retailer/authorized repairer for the work to be completed.

Question 18

How long does it take for the vehicle to be repaired?

Answer

The work will be completed as quickly and efficiently as possible in order to minimize inconvenience to customers. The actual repair takes approximately 18 minutes.

Question 19

Can I safely continue to drive my vehicle until it has been repaired?

Answer

Customers are advised to contact a retailer/authorized repairer should they have any concerns regarding their vehicles.

Note:

Please make sure that any press enquiries are referred to the JLR Corporate Affairs office.