



## SIB 64 05 21

2022-04-19

## RATTLING NOISE PERCEPTIBLE IN VEHICLE INTERIOR WITH AC ACTIVATED

This Service Information Bulletin (Revision 1) replaces SI B64 05 21 **dated June 2021**.

**What's New** (Specific text highlighted):

- Cause / Correction / Procedure / Parts / Warranty -Updated repair procedure
- Situation / Cause - Video attachments added

**MODEL**

E-Series	Model Description	Production Date
G20	3 Series Sedan	Start of Production up to May 30 2025

**SITUATION**

A rattling noise is heard in the vehicle interior when the air conditioning (AC) is activated.

See attached video: [BV64 01 22\\_G20 Drone noise while driving](#)

**MODEL**

E-Series	Model Description	Production Date
G20	3 Series Sedan	From Start of Production

**SITUATION**

A rattling noise is heard in the vehicle interior when the air conditioning is activated.

**CAUSE**

The refrigerant line double pipe and a clamp on the return line of the internal heat exchanger are in line with each other (in the direction of travel, on the left (driver) side of the engine compartment below/behind the DME).and are making contact.

See attached video: [BV64 02 22\\_G20 Drone noise source](#)

**CORRECTION**

Insert a spacer between the coolant hoses underhood, and strips of felt tape in the area of contact between lines below the instrument panel.

**PROCEDURE**

For the situation described above, proceed as follows.

	The hoses are contacting here (arrow).
--	--



Mount a spacer (part number 11 53 7 537 923) in the engine compartment between the coolant hose feed and coolant hose return. The coolant hoses have to be turned about 10 to 15 degrees in the direction of the bulkhead.

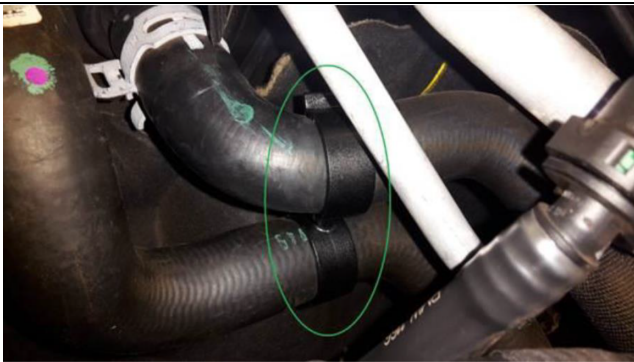

Close up view of spacer installed.

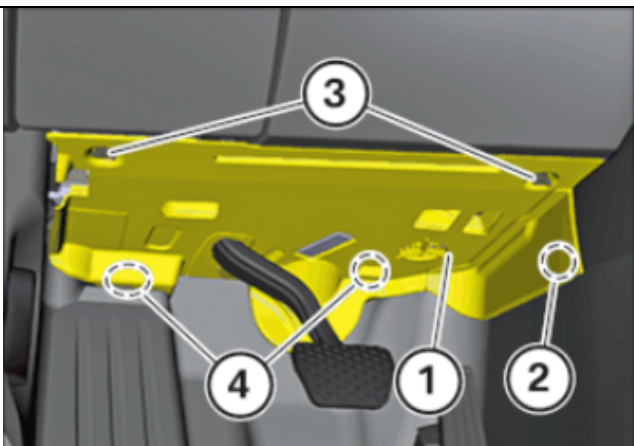

If the complaint still occurs after installing the spacer, the following must also be done: Remove the trim panel for pedal mechanism. See repair instructions REP 5145186



Tape the two heat exchanger lines with a felt strip (part number: 51 45 2 353 024) 4-5 inches (10-12 cm) long around each of the lines. Secure the lines together using a worm-type hose clamp (part number 07 12 9 952 117).

This prevents the lines moving in the aperture grommet.

See attached video:

[BV64 02 22\\_G20 Drone noise source](#)

Then remount the trim panel for pedal mechanism and reassess the vehicle.

## **PARTS INFORMATION**

Obtain and confirm the part numbers for your specific vehicle by entering the chassis number in either ETK or AIR which takes into account specific equipment and/or options.

Part Number	Description	Quantity
51 45 2 353 024	Felt tape	25cm max
07 12 9 952 117	Hose Clamp	1
11 53 7 537 923	Spacer (originally for E83 vehicles)	1

## **WARRANTY INFORMATION**

Covered under the terms of the BMW New Vehicle Limited Warranty for Passenger Cars and Light Trucks.

<b>Defect Code:</b>	<b>6453003900</b>	<b>Refrigerant line of Air conditioning Unpleasant noises</b>
---------------------	-------------------	---

Refer to AIR for the FRU allowances.

Labor Operation	Description	Labor Allowance
12 90 150	Remove and install control unit box (For access) (Main work)	Refer to AIR
Or:		
12 90 650	Remove and install control unit box (For access) (Plus work)	Refer to AIR
And:		
64 99 000	Work time to install the clamp and felt strip	2 FRU
And, if necessary:		
51 45 684	Removing and installing trim panel for pedal assembly	Refer to AIR
And:		
64 99 000	Work time to tape the two heat exchanger lines with a felt strip (includes the 2 FRU above to install the clamp and felt strip)	4 FRU

If you are using a Main labor code for another repair, use the Plus code labor operation 12 90 650 instead of 12 90 150.

For the above, only claim Work time labor operation code 64 99 000, one time, for either 2 FRU or 4 FRU as applicable for the repair that as performed.

Or, if the engine compartment repair was performed prior to the March 2022 Bulletin update.

Labor Operation	Description	Labor Allowance
51 45 184	Removing and installing trim panel for pedal assembly (Main work)	Refer to AIR
Or:		
51 45 684	Removing and installing trim panel for pedal assembly (Plus work)	Refer to AIR
And:		
64 99 000	Work time to tape the two heat exchanger lines with a felt strip	2 FRU

If you are using a Main labor code for another repair, use the Plus code labor operation 51 45 684 instead of 51 45 184.

And, as needed:

#### Sublet – Bulk Materials (RO and Claim Comments Required)

<b>Sublet Code 4</b>	See the sublet reimbursement calculations below	Reimbursement for the repair-related bulk material (Do not use the BMW part number for claim submission)
----------------------	---	--

Sublet reimbursement calculation for claiming the applicable repair-related bulk material (BMW part numbers) is at the dealer net price amount for the quantity used plus your center's handling.

Enter this material cost in sublet and itemize the amount on the repair order and in claim comment section

Based on which one applies to your center, please refer to **SI B01 01 20** or **B01 07 20** for the applicable procedure for documenting, claiming, and explaining, on the RO and in the claim comments, your diagnosis work time (WT), job/repair work time (WT), and the vehicle repairs your center performed, unless otherwise required by State law.

### QUESTIONS REGARDING THIS BULLETIN

Technical inquiries	Submit feedback at the top of this bulletin
Warranty inquiries	Please contact the Warranty department by either using the Live Chat that's available in the Warranty Documentation Portal or through IDS by selecting Coverage, Policy, Coding Questions and Mileage Corrections
Parts inquiries	Submit an IDS ticket to the Parts Department

#### Supporting Materials

##### Videos

[64 01 22](#)

[64 02 22](#)