

Classification:  
AN20-026DReference:  
ITB20-021DDate:  
March 21, 2022

## SOFTWARE UPDATE FOR INFOTAINMENT ISSUES

This bulletin has been amended. See AMENDMENT HISTORY on the last page.  
Please discard previous versions of this bulletin.

**APPLIED VEHICLES:** 2020-2021 Q50 (V37)  
2020-2021 Q60 (CV37)  
2020-2021 QX50 (J55)  
2020-2021 QX80 (Z62)

### SERVICE INFORMATION

When diagnosing an infotainment issue, always confirm that the latest software is installed in the AV control unit before starting the diagnosis.

The update-software in the following **SERVICE PROCEDURE** is for the items below:

- Stability improvements and "bug" fixes

Refer to steps 1 - 4 to confirm that this bulletin applies.

**NOTE:** Download infotainment update-software "PVI002" if this bulletin applies.

Infiniti Bulletins are intended for use by qualified technicians, not 'do-it-yourselfers'. Qualified technicians are properly trained individuals who have the equipment, tools, safety instruction, and know-how to do a job properly and safely. **NOTE:** If you believe that a described condition may apply to a particular vehicle, DO NOT assume that it does. See your Infiniti retailer to determine if this applies to your vehicle.

## REQUIRED SPECIAL TOOL

- One special tool, USB drive J-52727-1, has been previously shipped to each retailer (Figure 1).
- Do not use any other USB drive to perform the procedure in this bulletin.
- Additional USB drives may be purchased from Tech•Mate: [infinitechmate.com](http://infinitechmate.com) or 1-800-662-2001. Part number: J-52727-1.

### HINT:

- The update-software only needs to be downloaded once and can then be used continuously on multiple **APPLIED VEHICLES**.
- The update-software must be the only file on the USB drive.



Figure 1

## SERVICE PROCEDURE

### Check Software Version

1. Press and hold the **AUDIO** button, and at the same time rotate the volume knob left and right until the **System Diagnostic Menu** displays (Figure 2 and Figure 3).



Figure 2

2. Select **Confirmation/Adjustment**.

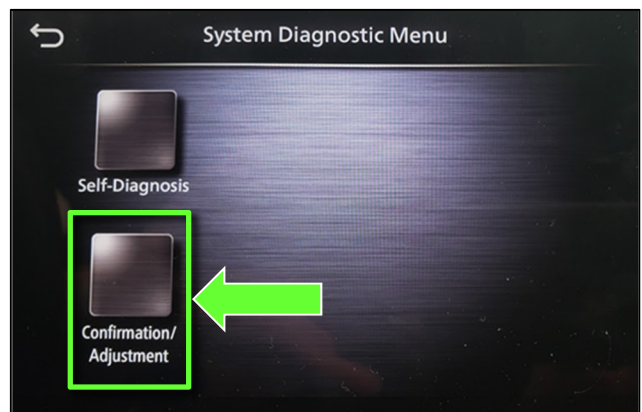

Figure 3

3. Scroll down and select **Version Information**.

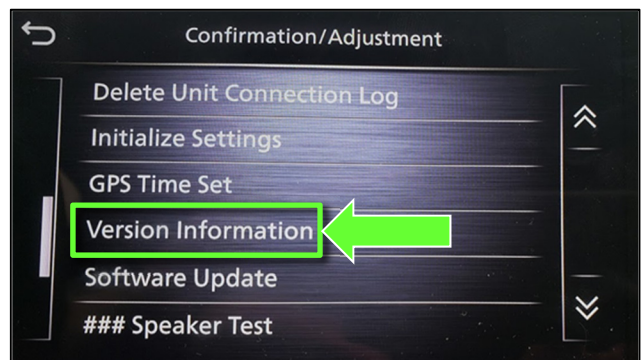

Figure 4

4. Confirm the **Software Version** number (Figure 5).

- If the Software Version (digits 6-9 as shown in Figure 5) is **lower** than xxxxx**2992**x, select the back button and continue to step 5 on the next page.
- If the Software Version is xxxxx**2992**x or higher (digits 6-9), select the back button; this bulletin does not apply. Refer to ASIST for further diagnostic information.

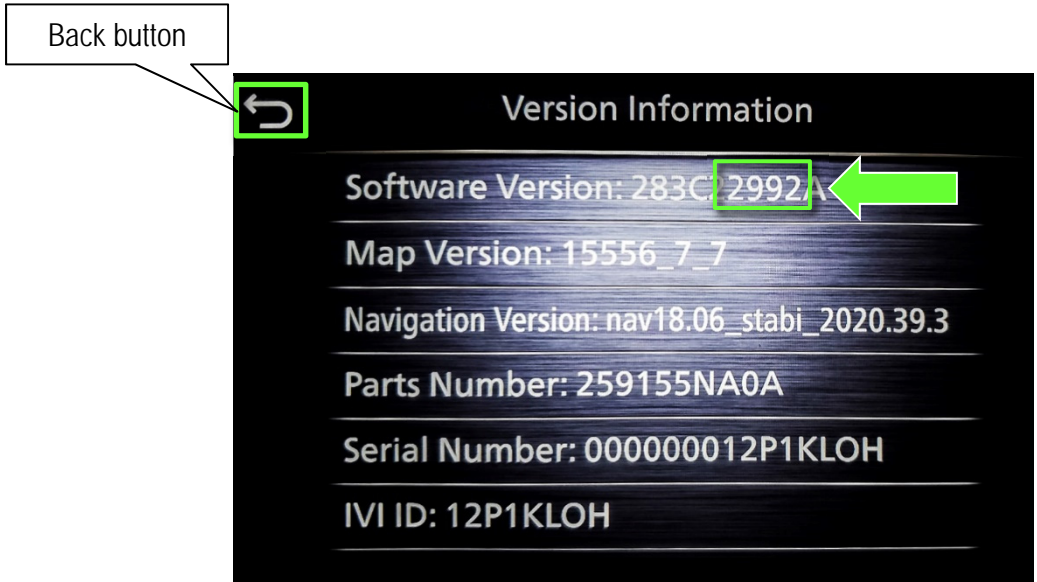

Figure 5

## Update AV Control Unit

**IMPORTANT:** Before starting, make sure:

- ASIST is connected to the internet.
- ASIST has been synchronized (updated) to the current date.

**NOTE:** In the following steps, if more than one CONSULT PC is available and the “PVI002” infotainment update-software has already been downloaded through ASIST to one of them, use the CONSULT PC with the pre-existing download.

5. Insert special tool USB drive J-52727 into a CONSULT PC.

- If the infotainment update-software has already been downloaded onto special tool USB drive J-52727 from a prior service procedure, skip to step 14 on page 7.

**HINT:**

- Special tool USB drive J-52727 is the only one approved for use with this procedure.
- The initial download of the update-software to the CONSULT PC and file transfer to the USB drive is estimated to take **6 hours**. After the initial download of the update-software, file transfer to the USB drive is estimated to take 1 hour.
- The update-software only needs to be downloaded once and can then be used continuously on multiple **APPLIED VEHICLES**.
  - The update-software must be the only file on the USB drive.

6. Open ASIST.

7. Select **Specialty Tools**, and then select **Infotainment Software Updates**.

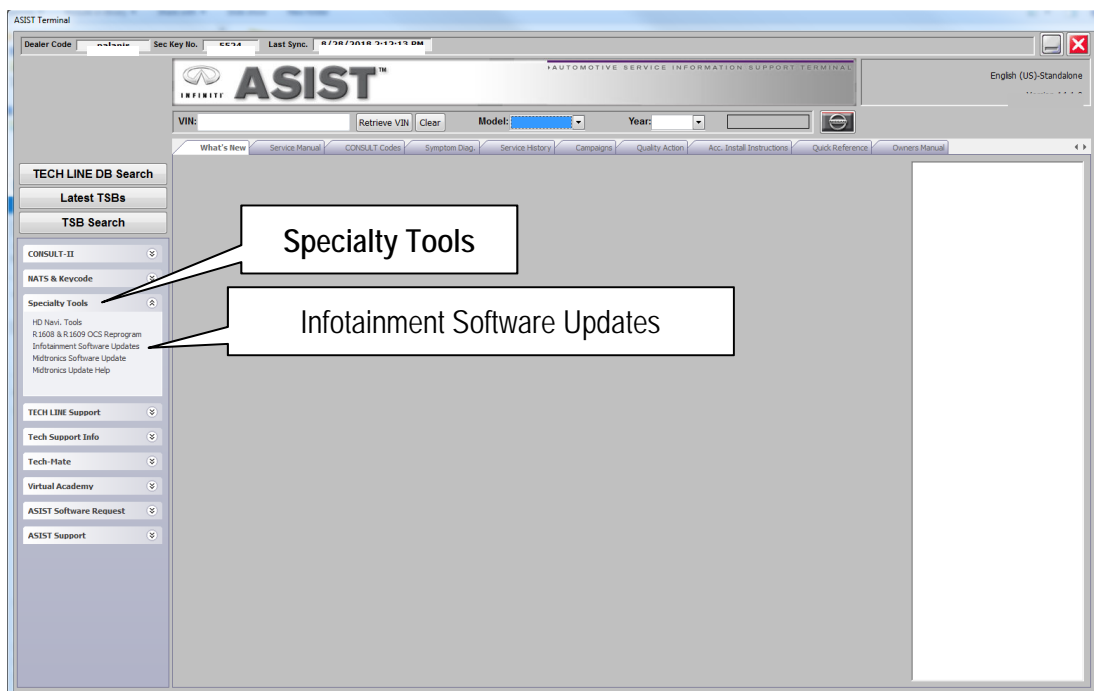

Figure 6

8. Select the check box next to the "PVI002" infotainment update-software (refer to Figure 7 below).
  - If the "PVI002" infotainment update-software has already been downloaded, "Transfer" will be displayed instead of "Download" when the infotainment software update box is checked.
9. Use the drop-down menu to select the location of the USB drive that was inserted in step 5 on page 5.

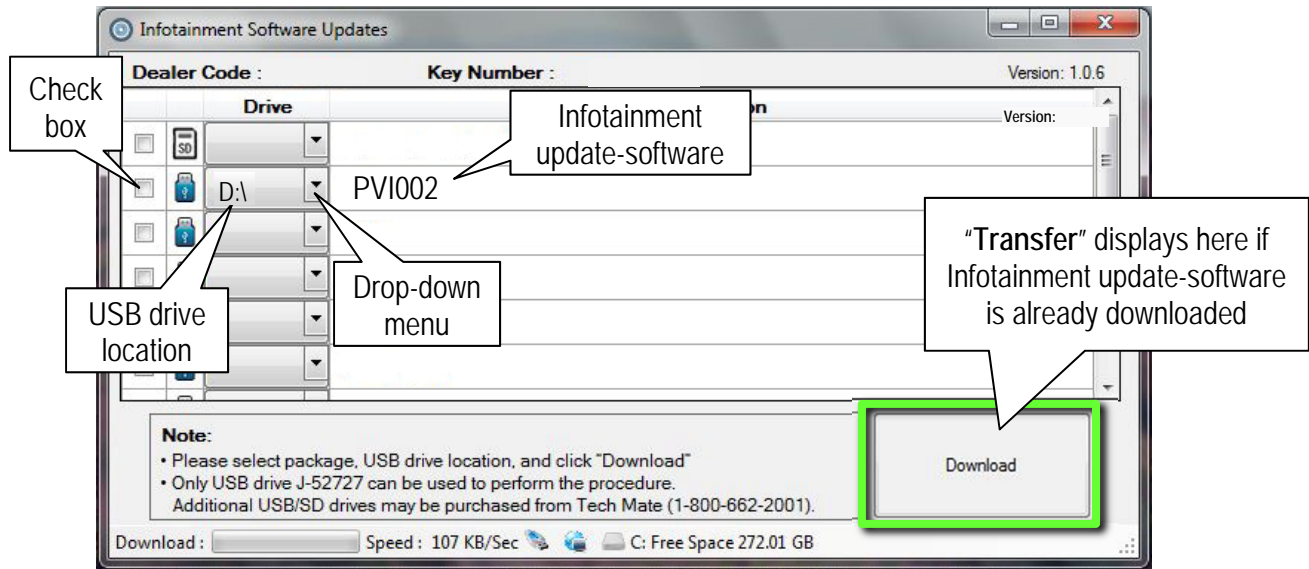

Figure 7

10. Select **Download**, and then wait for the download to complete.

**HINT:**

- The initial download of the update-software to the CONSULT PC and file transfer to the USB drive is estimated to take **6 hours**. After the initial download of the update-software, file transfer to the USB drive is estimated to take 1 hour.
- If while attempting to download the update-software to the CONSULT PC, you receive the message shown in Figure 8:
  - a. First attempt to clear space on the CONSULT PC hard drive (40 GB required).
  - b. If space cannot be cleared and a second CONSULT PC is available with space, use it and start over from step 5.



Figure 8

11. Select **OK**.

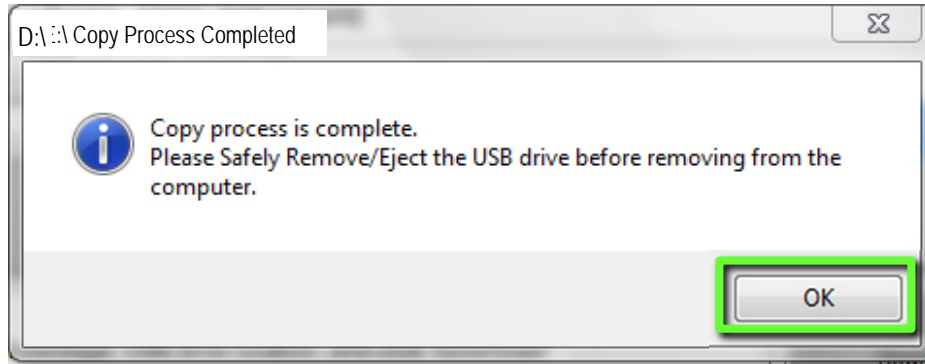

Figure 9

12. Once the transfer is complete, safely remove the USB drive from the CONSULT PC.

- a. From the PC toolbar, select the **Safely Remove Hardware** icon.
  - o The icon is on the toolbar, or can be found after selecting the arrow.
- b. Select the USB drive to be removed, and then remove the USB drive from the CONSULT PC.

**NOTICE**

Follow the steps to safely remove the USB drive. If not followed, the USB drive may corrupt the infotainment update-software.

- o If you are not familiar with the process of safe USB drive removal, ask for assistance at your retailer.

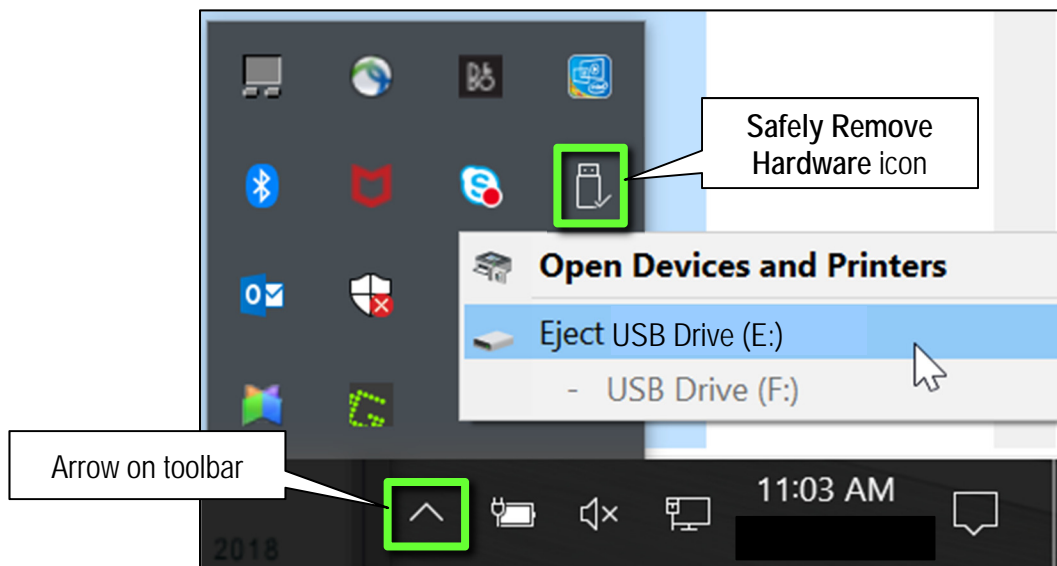

Figure 10

13. Close all ASIST **Infotainment Software Update** screens.

14. Set the parking brake.

15. Start the engine, and then wait 60 seconds for the system to load.

**HINT:** The engine needs to idle for the duration of the update to retain battery charge.

16. Insert the USB drive with infotainment update-software into the vehicle's USB media port (Figure 11).
- Do not remove the USB drive during the update to the vehicle until instructed.

**HINT:** Charging ports are marked in the vehicle with a "lightning bolt" symbol.

**NOTICE**

Do not insert the USB drive into a charging port. If used, the update-software and/or USB drive may become damaged. Only insert the USB drive in a USB media port.

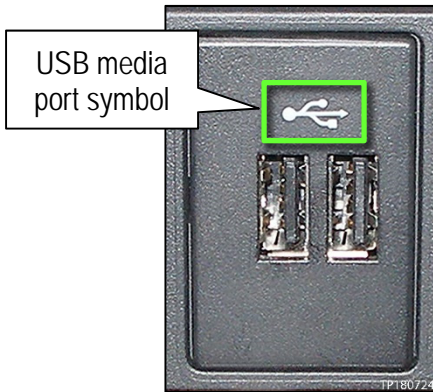

Figure 11

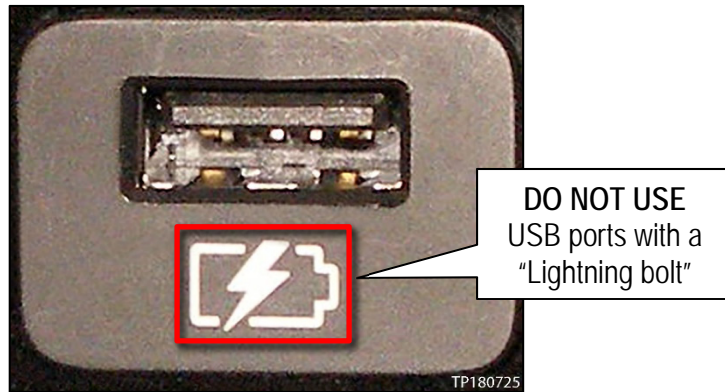

Figure 12

17. Wait for the update to complete.
- Follow the on-screen instructions while waiting.

**HINT:** The update lasts 15-25 minutes.

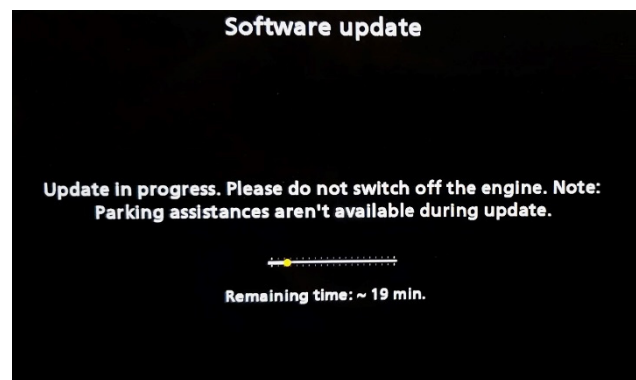

Figure 13

18. Once the update is complete (Figure 14), remove the USB drive; the system will reboot (restart).  
**HINT:** The system will not reboot until the USB drive is removed.

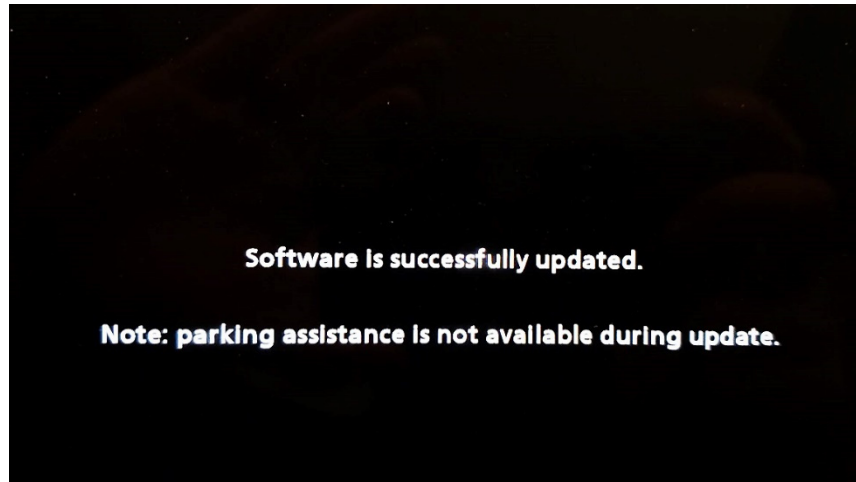

Figure 14



Figure 15

## NOTICE

Steps 19-26 must be completed. If they are not completed, the update may become corrupt.

19. Allow the reboot to complete (approximately 30 seconds).
  - The Infiniti logo will be displayed during the reboot.
20. Turn the ignition OFF.



Figure 16

The steps below will fully reboot the infotainment system twice.

21. Open and close the driver door and ensure that all doors are closed.
22. Wait 5 minutes.

## NOTICE

Ensure that all doors remain closed during the 5-minute wait period. If a door is opened during the 5-minute wait period, the update may not complete and the AV control unit may become inoperable.

**HINT:** The engine does not need to be running for the next steps.

23. Turn the ignition ON (engine OFF) and wait for the Infiniti logo to appear (Figure 16).
  - If the Infiniti logo does not appear (this might take up to 30 seconds), start over from step 20.

24. After the Infiniti logo appears, wait about 1 minute.
  - The MENU (Home) screen in Figure 17 will be displayed.



Figure 17

26. Repeat steps 21-25 one more time, for a total of two (2) times.
27. For QX80 vehicles only, proceed to **Additional Procedure for QX80 Vehicles** on the next page.

## Additional Procedure for QX80 Vehicles

28. Using a suitable tool, detach the Upper Ventilator Grille but do not remove it.

29. Disconnect the Sunload Sensor harness.

### **NOTICE**

To avoid damage to the Sunload Sensor harness, it must be disconnected before performing the next steps. If not disconnected, damage to Sunload Sensor harness may occur.

30. Remove the Upper Ventilator Grille.

### **NOTICE**

To avoid damage to the Instrument Panel and/or Center Speaker, the Upper Ventilator Grille must be completely removed before performing the next steps. If not removed, damage to the Instrument Panel and/or Center Speaker may occur.

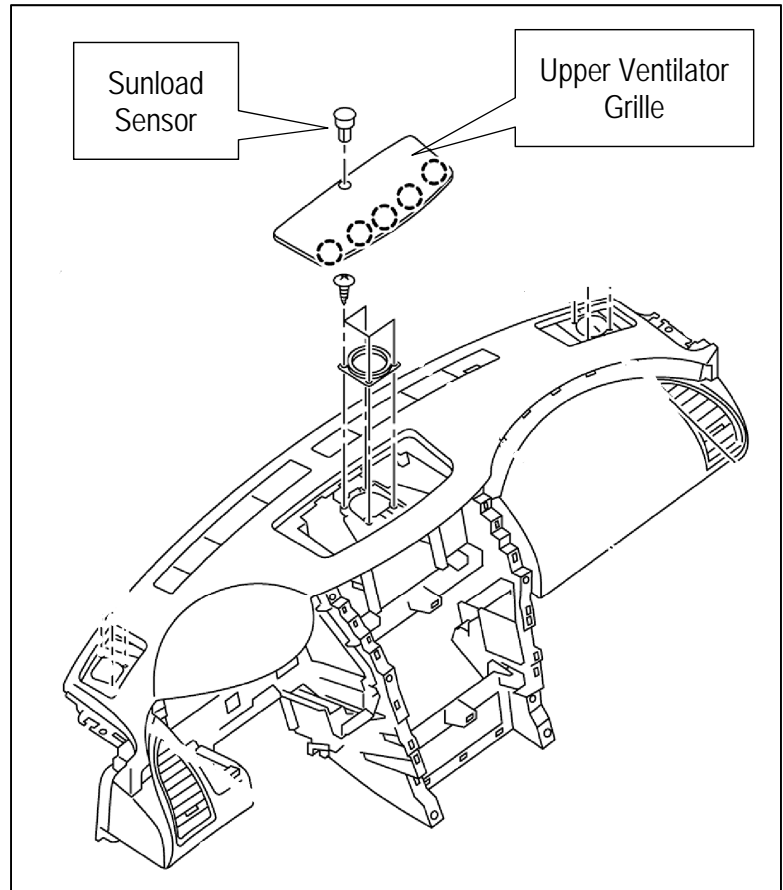

Figure 18

31. Turn the headlamps ON.

32. Drive the vehicle 3-6 miles AND for a minimum of 10 minutes.

33. Turn the engine OFF, and wait 5 minutes before proceeding to the next step.

**NOTE:** The ignition must also be OFF during this time.

34. Drive the vehicle a short distance (approximately ¼ mile).

35. Confirm the navigation system is displaying the correct location.

- If the correct location is not displayed, perform steps 32-35 again.

36. Turn the headlamps OFF.

37. Reattach the Sunload Sensor harness and the Upper Ventilator Grille.

## CLAIMS INFORMATION

Submit a Primary Operation (PO) type line claim using the following claims coding:

DESCRIPTION	OP CODE	SYM	DIA	FRT
Perform Software Check	RX9KAA	ZE	32	0.2

OR

Submit a Primary Operation (PO) type line claim using the following claims coding:

DESCRIPTION	OP CODE	SYM	DIA	FRT
Perform Software Check and Update	RX9JAA	ZE	32	0.3

Additional Claims Information for QX80 Only, submit on a separate line

Submit a Primary Operation (PO) type line claim using the following claims coding:

DESCRIPTION	OP CODE	SYM	DIA	FRT
Perform QX80 Vent Grille Procedure	RXA8AA	ZE	32	0.5

## AMENDMENT HISTORY

PUBLISHED DATE	REFERENCE	DESCRIPTION
August 31, 2020	ITB20-021	Original bulletin published
February 3, 2021	ITB20-021A	Classification number updated
March 15, 2021	ITB20-021B	APPLIED VEHICLES revised, changes made on pages 2, 4-6 and 8-10, and a NOTE added to page 1
February 25, 2022	ITB20-021C	QX80 removed from <b>APPLIED VEHICLES</b> , Bosch contact information removed, and infotainment update-software name revised on pages 1, 5, and 6
March 21, 2022	ITB20-021D	QX80 added to <b>APPLIED VEHICLES</b> , infotainment update-software name revised on pages 1, 5, and 6, <b>HINT</b> on pages 5 and 6 revised, <b>Additional Procedure for QX80 Vehicles</b> added, and <b>CLAIMS INFORMATION</b> revised