

Technical Service Bulletin

Mazda North American Operations
Irvine, CA 92618-2922



Subject: SQUEAK NOISE FROM REAR BRAKES DURING LIGHT BRAKING	Bulletin No.: 04-002/22
	Last Issued : 04/19/2022

BULLETIN NOTES

This bulletin supersedes the previously issued bulletin(s) listed below. The changes are noted in Red text.

Previous TSBs:	Date(s) Issued:
04-005/20	12/10/20
04-005/20	03/06/19
04-004/19	09/16/19

APPLICABLE MODEL(S)/VINS

US Spec.:

2016-2021 CX-5

Mexico Spec.:

2017-2021 CX-5

DESCRIPTION

Some vehicles may exhibit a squeak noise from the rear brakes while braking lightly. The squeak noise may occur more frequently when driving at slow speeds. The noise is caused by poor contact between the guide plate and the mounting support.

Customers having this concern should have their vehicle repaired using the following repair procedure.

CONSUMER NOTICE: The information and instructions in this bulletin are intended for use by skilled technicians. Mazda technicians utilize the proper tools/ equipment and take training to correctly and safely maintain Mazda vehicles. These instructions should not be performed by "do-it-yourselfers." Customers should not assume this bulletin applies to their vehicle or that their vehicle will develop the described concern. To determine if the information applies, customers should contact their nearest authorized Mazda dealership. Mazda North American Operations reserves the right to alter the specifications and contents of this bulletin without obligation or advance notice. All rights reserved. No part of this bulletin may be reproduced in any form or by any means, electronic or mechanical---including photocopying and recording and the use of any kind of information storage and retrieval system ---without permission in writing.

REPAIR PROCEDURE

1. Verify the customer's concern.
2. Remove the rear brake pads according to the instructions on MGSS online (REAR BRAKE DISC PAD REMOVAL/ INSTALLATION).

NOTE: If the brake pads are worn, replace them at customer expense.

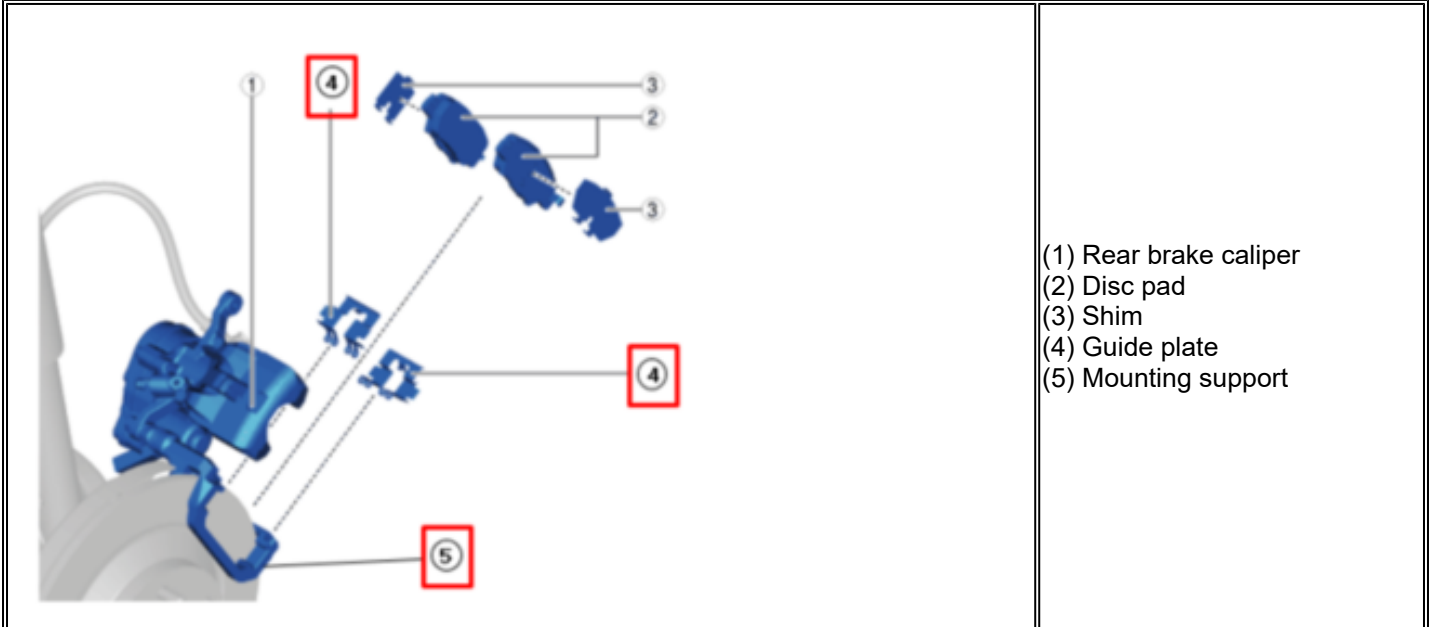

3. Degrease and clean the **contact surfaces of both mounting supports with brake cleaner.**

Mounting Support

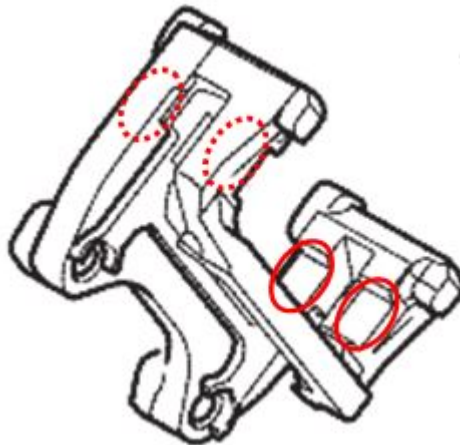

CONSUMER NOTICE: The information and instructions in this bulletin are intended for use by skilled technicians. Mazda technicians utilize the proper tools/ equipment and take training to correctly and safely maintain Mazda vehicles. These instructions should not be performed by "do-it-yourselfers." Customers should not assume this bulletin applies to their vehicle or that their vehicle will develop the described concern. To determine if the information applies, customers should contact their nearest authorized Mazda dealership. Mazda North American Operations reserves the right to alter the specifications and contents of this bulletin without obligation or advance notice. All rights reserved. No part of this bulletin may be reproduced in any form or by any means, electronic or mechanical---including photocopying and recording and the use of any kind of information storage and retrieval system ---without permission in writing.

4. Verify if the tape is installed to both guide plates (some kits do not have the tape installed and is packaged separately).

- If the tape is not applied to the guide plates, peel off the red release film (1) and the dual adhesive tape (2) from the release paper (3) and apply the dual adhesive tape to the contact surfaces of the guide plates as shown below.

NOTE: DO NOT touch the sticky surface of the dual adhesive tape.

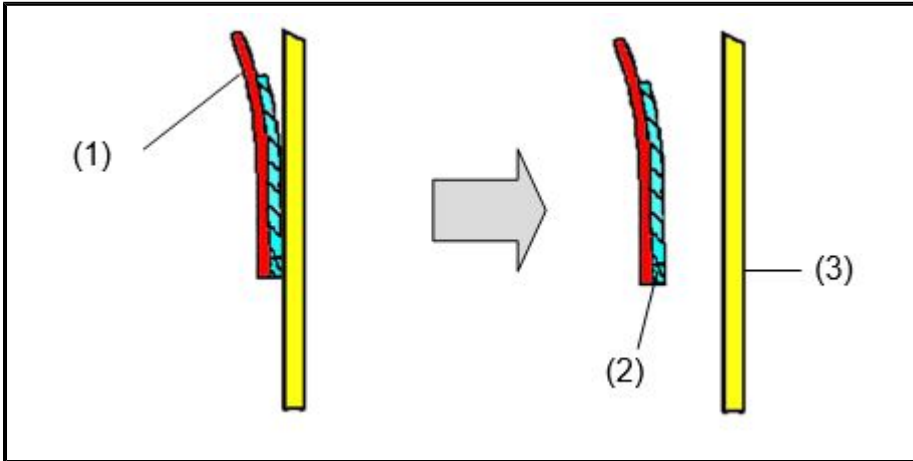

NOTE: DO NOT apply the dual adhesive tape beyond the contact surfaces of the guide plates.

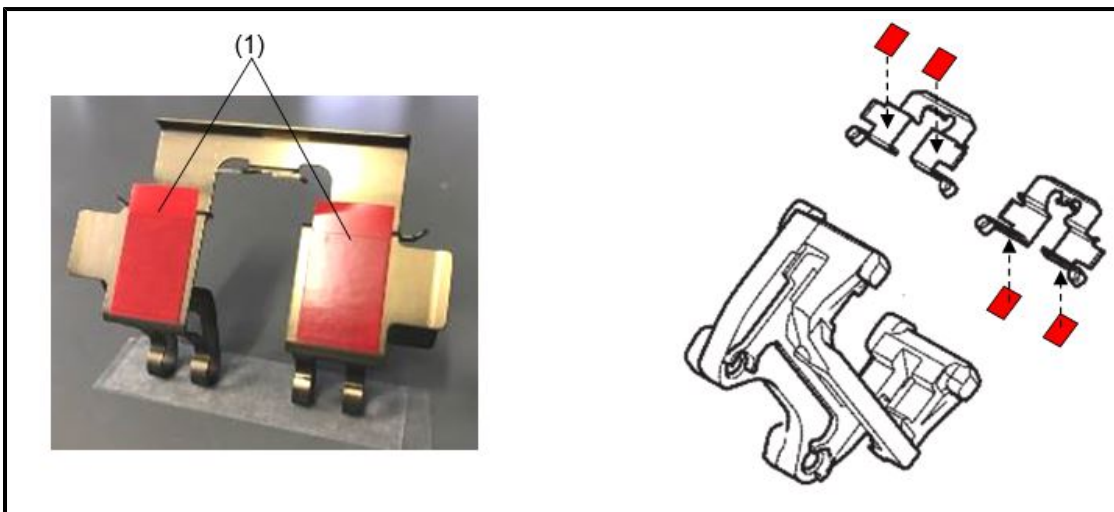

CONSUMER NOTICE: The information and instructions in this bulletin are intended for use by skilled technicians. Mazda technicians utilize the proper tools/ equipment and take training to correctly and safely maintain Mazda vehicles. These instructions should not be performed by "do-it-yourselfers." Customers should not assume this bulletin applies to their vehicle or that their vehicle will develop the described concern. To determine if the information applies, customers should contact their nearest authorized Mazda dealership. Mazda North American Operations reserves the right to alter the specifications and contents of this bulletin without obligation or advance notice. All rights reserved. No part of this bulletin may be reproduced in any form or by any means, electronic or mechanical--including photocopying and recording and the use of any kind of information storage and retrieval system ---without permission in writing.

5. Peel off the red release film from the dual adhesive tape.

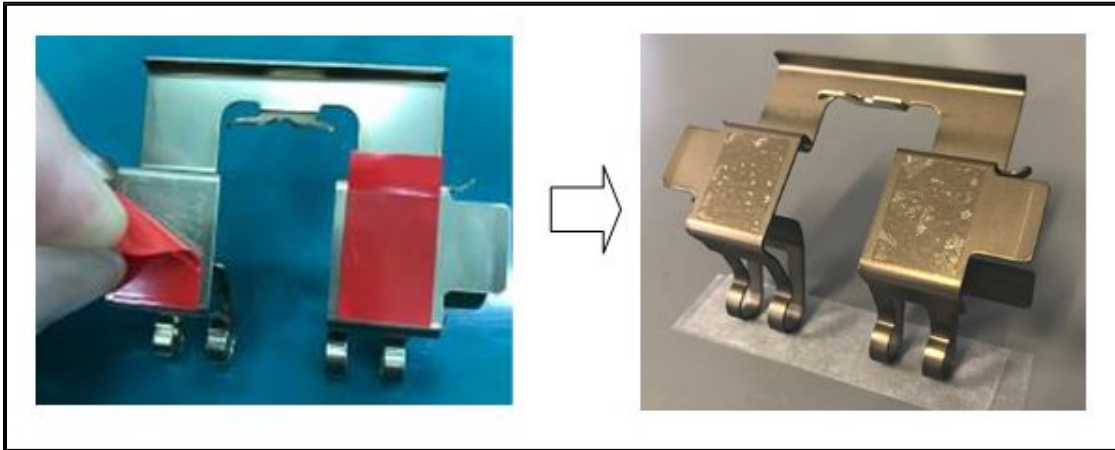

NOTE: When reinstalling the guide plates, do not allow a gap between the guide plate and mounting support.

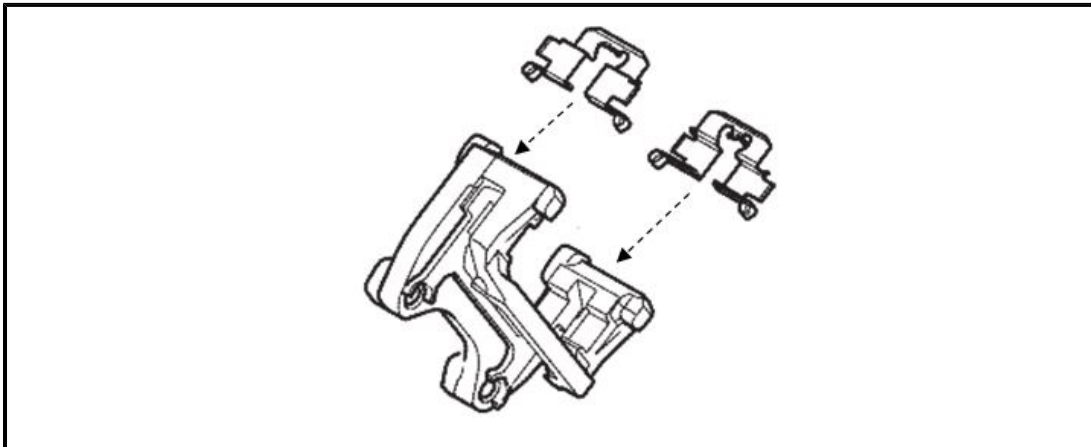

6. Reinstall the rear brake pads according to the instructions on MGSS online (REAR BRAKE DISC PAD REMOVAL/ INSTALLATION).

7. Step on the brake pedal several times to verify the brakes operate properly before moving the vehicle.

8. Verify the repair.

CONSUMER NOTICE: The information and instructions in this bulletin are intended for use by skilled technicians. Mazda technicians utilize the proper tools/ equipment and take training to correctly and safely maintain Mazda vehicles. These instructions should not be performed by "do-it-yourselfers." Customers should not assume this bulletin applies to their vehicle or that their vehicle will develop the described concern. To determine if the information applies, customers should contact their nearest authorized Mazda dealership. Mazda North American Operations reserves the right to alter the specifications and contents of this bulletin without obligation or advance notice. All rights reserved. No part of this bulletin may be reproduced in any form or by any means, electronic or mechanical---including photocopying and recording and the use of any kind of information storage and retrieval system ---without permission in writing.

PARTS INFORMATION

Part Number	Description	Qty.	Note
KBY6-26-49Z	Attachment, Pad Rear	1	<p>Also known as Guide Plate (This is the only part covered by Warranty)</p> <ul style="list-style-type: none"> If vehicle needs brake pads, order KBY6-26-43Z (Pad Set, RR Caliper) which includes Attachment with Pad Sub Set.

WARRANTY INFORMATION**NOTE:**

- This warranty information applies only to verified customer complaints on vehicles eligible for warranty repair.
- This repair will be covered under Mazda's New Vehicle Limited Warranty term.
- Additional diagnostic time cannot be claimed for this repair.
- This TSB does not apply if rear brake pads are worn and need to be replaced using KBY6-26-43Z (Pad Set, RR Caliper) which includes attachment (guide plate). Replace brake pads at customer expense.

Warranty Type	A
Symptom Code	35
Damage Code	97
Part Number Main Cause	KBY6-26-49Z (Attachment, Pad Rear (Guide Plate))
Quantity	1
Operation Number / Labor Hours:	XXR8GARX / 0.3 Hr.

CONSUMER NOTICE: The information and instructions in this bulletin are intended for use by skilled technicians. Mazda technicians utilize the proper tools/ equipment and take training to correctly and safely maintain Mazda vehicles. These instructions should not be performed by "do-it-yourselfers." Customers should not assume this bulletin applies to their vehicle or that their vehicle will develop the described concern. To determine if the information applies, customers should contact their nearest authorized Mazda dealership. Mazda North American Operations reserves the right to alter the specifications and contents of this bulletin without obligation or advance notice. All rights reserved. No part of this bulletin may be reproduced in any form or by any means, electronic or mechanical---including photocopying and recording and the use of any kind of information storage and retrieval system ---without permission in writing.