

GLOBAL SAFETY FIELD INVESTIGATIONS
DCS6130
URGENT - DISTRIBUTE IMMEDIATELY

Date: April 14, 2022

Subject: N212351811 - Customer Satisfaction Program
Poor Hem Flange and Shy Sealer in Rear Wheelhouses

Models: 2021 Buick Enclave

To: All General Motors Dealers

General Motors is releasing Customer Satisfaction Program N212351811 today. The total number of U.S. vehicles involved is approximately 604. Please see the attached bulletin for details.

Customer Letter Mailing

The customer letter mailing will begin on April 28, 2022.

Global Warranty Management (GWM)

The Required Field Action section on the Investigate Vehicle History (IVH) screen will be updated April 14, 2022. Please hold all warranty transactions until IVH has been updated.

END OF MESSAGE
GLOBAL SAFETY FIELD INVESTIGATIONS

Customer Satisfaction Program

N212351811 Poor Hem Flange and Shy Sealer in Rear Wheelhouses



Release Date: April 2022

Revision: 00

Attention: This program is in effect until May 31, 2024.

Make	Model	Model Year		RPO	Description
		From	To		
Buick	Enclave	2021	2021		

Involved vehicles are marked "open" on the Investigate Vehicle History screen in GM Global Warranty Management system. This site should always be checked to confirm vehicle involvement prior to beginning any required inspections and/or repairs.

Condition	Certain 2021 model year Buick Enclave vehicles may have a condition where both rear wheelhouse and the driver side hem flange have missing sealer.
Correction	Dealers are to apply the missing sealer.

Parts

Quantity	Part Name	Part No.
1	Kent Automotive High-Tech Seam Sealer-Clear *	P10200

* Contact Kent Automotive at 1-888-937-5368 (USA), 1-800-563-1717 (Canada), or www.kent-automotive.com. Dealers that do not have a Kent Automotive account or representative must advise the Customer Service Representative that the part(s) is being used for this GM bulletin to obtain special bulletin pricing. **Do not order from GMCCA.**

Warranty Information

Labor Operation	Description	Labor Time	Trans. Type	Net Item
9106279	Reseal Left and Right Rear Wheelhouses and Left Rear Hem Flange	1.0	ZFAT	*

* The amount identified in "Net Item" should represent the actual sum total of the current GMCC&A Dealer net price for Kent Automotive High-Tech Seam Sealer-Clear needed to perform the required repairs, not to exceed \$1.75 USD (\$2.25 CAD). One Tube of Kent Automotive High-Tech Seam Sealer-Clear will service 10 vehicles.

Service Procedure

1. Raise the vehicle on a hoist. Refer to *Lifting and Jacking* in SI.
2. Partially remove the left and right rear wheelhouse liners, it is only necessary to remove the 4 front fasteners and the air deflector. Carefully fold the wheelhouse liners allowing access to the work area. Refer to *Rear Wheelhouse Liner Replacement* in SI.



6043068

Customer Satisfaction Program

N212351811 Poor Hem Flange and Shy Sealer in Rear Wheelhouses



3. Locate the skip in the sealer on the left and right-side inner wheelhouse. See the graphic for the area to be sealed.

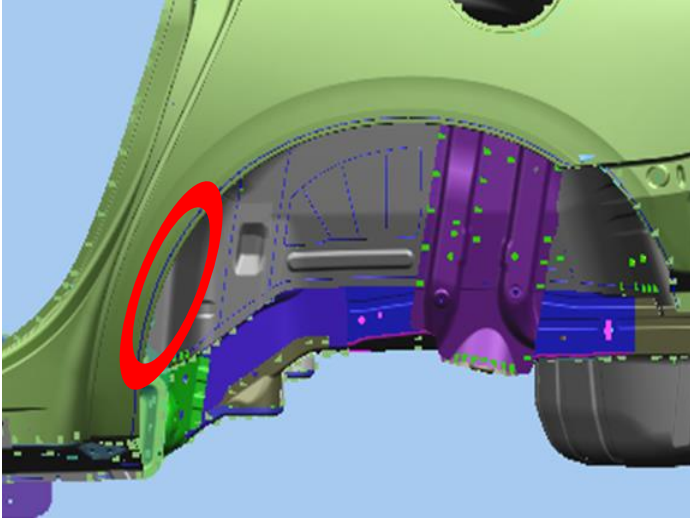

6041878

4. Locate the out of position seam sealer between the outer wheel well and the outer panel hem flange. See the above graphics for the sealing location. The actual sealing area is on the inside of this area.
5. Clean the sealing areas with a general-purpose adhesive remover.



6041800

Customer Satisfaction Program

N212351811 Poor Hem Flange and Shy Sealer in Rear Wheelhouses



6043067

6. Using Kent Automotive High-Tech Seam Sealer-Clear, seal the left and right wheelhouse joints and left side hem flange area identified in the graphics above. Ensure the complete area is sealed. Smooth the sealer with a small brush to ensure coverage. Note that **only the left side hem flange requires sealing**.
7. To avoid contaminating the wheelhouse liner material, allow the seam sealer to cure per the manufacturer's instructions.
8. Reinstall the wheelhouse liners and fasteners as required. Refer to *Rear Wheelhouse Liner Replacement* in SI.

Dealer Responsibility

All new, used, GM Certified Used, courtesy transportation vehicles, dealer shuttle vehicles, etc. in dealers' possession and subject to this program must be held and inspected/repared per the service procedure of this bulletin before customers take possession of these vehicles. Involved vehicles must be held and not delivered to customers, dealer-traded, released to auction, used for demonstration, or any other purpose.

All GM Certified Used vehicles currently in the dealers' inventory within the Certified Pre-Owned Inventory System (CPOIS) will be de-certified and must be held and remedied per the service procedure in this bulletin. Upon submitting an accepted/paid warranty transaction in the Global Warranty Management (GWM) system, the vehicle can be re-certified for sale within the CPOIS system, or once again be used in the CTP program.

Dealers are to service all vehicles subject to this program at no charge to customers, regardless of mileage, age of vehicle, or ownership, through May 31, 2024. Customers who have recently purchased vehicles sold from your vehicle inventory, and for which there is no customer information indicated on the involved vehicle listing, are to be contacted by the dealer. Arrangements are to be made to make the required correction according to the instructions contained in this bulletin. A copy of the customer letter is provided in this bulletin for your use in contacting customers. Program follow-up cards should not be used for this purpose, since the customer may not as yet have received the notification letter.

In summary, whenever a vehicle subject to this program enters your vehicle inventory or is in your facility for service through May 31, 2024, you must take the steps necessary to be sure the program correction has been made before selling or releasing the vehicle.

Dealer Reports – For USA

For dealers with involved vehicles, a listing has been prepared and will be available through GM GlobalConnect Maxis Field Action Reports or sent directly to export dealers. The Inventory tab of the dealer reports will contain VINs that apply to this field action. This information is intended to assist dealers with the **PROMPT COMPLETION** of these vehicles. The Customer In-Service tab will contain customer names and addresses from Motor Vehicle Registration Records. The use of such motor vehicle registration data for any purpose other than follow-up necessary to complete this field action may be a violation of law in several states.

Customer Satisfaction Program

N212351811 Poor Hem Flange and Shy Sealer in Rear Wheelhouses



Courtesy Transportation – For USA & Canada

Courtesy transportation is available for customers whose vehicles are involved in a product program and still within the warranty coverage period. See General Motors Service Policies and Procedures Manual for courtesy transportation program details.

Customer Notification

USA & Canada - General Motors will notify customers of this program on their vehicle (see copy of customer letter included with this bulletin).

GM bulletins are intended for use by professional technicians, NOT a "do-it-yourselfer". They are written to inform these technicians of conditions that may occur on some vehicles, or to provide information that could assist in the proper service of a vehicle. Properly trained technicians have the tools, equipment, safety instructions, and know-how to do a job properly and safely. If a condition is described, DO NOT assume that the bulletin applies to your vehicle, or that your vehicle will have that condition. See your dealer for information on whether your vehicle may benefit from the information.



**We Support
Voluntary Technician
Certification**

Customer Satisfaction Program

N212351811 Poor Hem Flange and Shy Sealer in Rear Wheelhouses



April 2022

This notice applies to your vehicle, **VIN:** _____

Dear General Motors Customer:

We have learned that your 2021 model year Buick Enclave may have a condition where both rear wheelhouse and the driver side hem flange have missing sealer.

Your satisfaction with your Buick Enclave is very important to us, so we are announcing a program to correct this condition.

What We Will Do: Your GM dealer will apply the missing sealer. This service will be performed for you at **no charge until May 31, 2024**. After that, any applicable warranty will apply.

What You Should Do: To limit any possible inconvenience, we recommend that you contact your dealer as soon as possible to schedule an appointment for this repair. By scheduling an appointment, your dealer can ensure that the necessary parts will be available on your scheduled appointment date.

If you have any questions or concerns that your dealer is unable to resolve, please contact the appropriate Customer Assistance Center at the number listed below.

For the hearing or speech impaired, please contact our Customer Assistance Center using the Telecommunication Relay Service by dialing 711 then providing the appropriate Customer Assistance Center number for your vehicle.

Division	Number	Text Telephones (TTY)
Buick	1-800-521-7300	711 / 1-800-833-2438
Puerto Rico – English	1-866-467-9700	
Puerto Rico – Español	1-866-467-9700	
Virgin Islands	1-866-467-9700	

We truly appreciate you taking the time to remedy your vehicle as we know your time is valuable. We want you to know that we will do our best, throughout your ownership experience, to ensure that your Buick Enclave provides you many miles of enjoyable driving.

Neelie O'Connor
Global Executive Director
Customer Experience Operations

N212351811