



Customer Outreach  
PO Box 8338  
Saint Joseph, MO 64508

[product.safety@altec.com](mailto:product.safety@altec.com)  
[connect.altec.com/login](https://connect.altec.com/login)

Phone 1-877-GO ALTEC  
Facsimile 1-877-659-9929

**This notice applies to your vehicle. Refer to the provided list.**

Original Equipment Manufacturer Customer Satisfaction Campaign benefiting Altec installed equipment and products distributed by Altec.

Dear Altec Owner,

Altec Industries, Inc. has been notified that an update exists based upon a notification from the Original Equipment Manufacturer (OEM) of the vehicle. This relates to the operation or customer satisfaction of the unit.

Refer to attached documentation that follows this letter. If you have additional questions, please contact your Altec Account Manager. You may also contact the OEM using the contact information in the attached notice.

If you have sold or retired the unit, update the records through Altec Connect or email [product.safety@altec.com](mailto:product.safety@altec.com). If you have leased this equipment to another person or company, you are required by Federal Law to forward a copy of this notice to the lessee by first class mail within ten (10) days of the receipt of this notice.

We appreciate your assistance in following this action in the interest of your safety and continued satisfaction with Altec products and products distributed by Altec.

Thank you for your immediate attention on this important matter.



Effer Safety Screw Inspection (Hiab Circular Letter N° 110/2021)

Units Affected: Certain Effer models with a safety screw at the extension cylinder. Verify your unit is affected by reviewing the attached list or accessing Altec Connect.

Background: Altec is committed to providing our customers reliable products from initial delivery throughout the useful life of the machine.

Hiab has updated the inspection procedure for the safety screw found at the extension cylinder.

Customer Action: Complete the inspection procedure as indicated in the updated information from Hiab. Add the supplemental pages to your unit's manual. Refer to the included communication from Hiab for additional information.

Completion and Warranty: This work is not covered under the Altec Warranty Policy.

Altec Contact Info:

Altec Connect: connect.altec.com/login



Phone: 1-877-GO ALTEC (1-877-462-5832) | Options: 1 - Parts; 2 - Shop Service; 3 - Mobile Service; 4 - Technical Support; 5 - Global Rental Service Request; 6 - Chassis Repair

Table with 2 columns: Description, Value. Rows include Inspection labor (0 hr), Repair labor (0 hr), Account # (NA), Travel (Not included), NHTSA code (NA), Prime fail P/N (NA), Doc ref (NA).

Table with 4 columns: Description, Part No., Qty, Warranty. Row includes NA, NA, NA, NA.



Minerbio,  
09-09-2021

## **CIRCULAR LETTER N° 110/2021**

Subject: **Safety Screw Extensions Cylinders**

### **Information**

We hereby inform you that part of regular maintenance is to perform a check on the safety screw on extensions cylinders. It will be duty of the operator to make a visual check once per week. It will be on Service Point to make a visual check. In case the screw is not in the proper position it is necessary to unscrew it completely, apply some loctite (type 222) and re-tighten it. Then mark it with a touch of paint, to allow the next visual check. Attached a picture to show you how it looks.

We remain at your disposal for further information.

**EFFER s.r.l.**  
**Società con socio unico soggetta**  
**a Direzione e Coordinamento**  
**di Cargotec Oyj**  
via IV Novembre, 12  
40061 Minerbio, (BO) - Italia  
Tel +390514181211  
e-mail: [contact@effer.com](mailto:contact@effer.com)

**[effer.com](http://effer.com)**

CCIAA di Bologna 452179  
VAT/C.F./P.IVA/Reg. Imp. BO (IT) 01943080224  
Fully Paid Up Capital € 1.600.000



**EFFER s.r.l.**  
**Società con socio unico soggetta**  
**a Direzione e Coordinamento**  
**di Cargotec Oyj**  
via IV Novembre, 12  
40061 Minerbio, (BO) - Italia  
Tel +390514181211  
e-mail: [contact@efffer.com](mailto:contact@efffer.com)  
**efffer.com**

CCIAA di Bologna 452179  
VAT/C.F./P.IVA/Reg. Imp. BO (IT) 01943080224  
Fully Paid Up Capital € 1.600.000

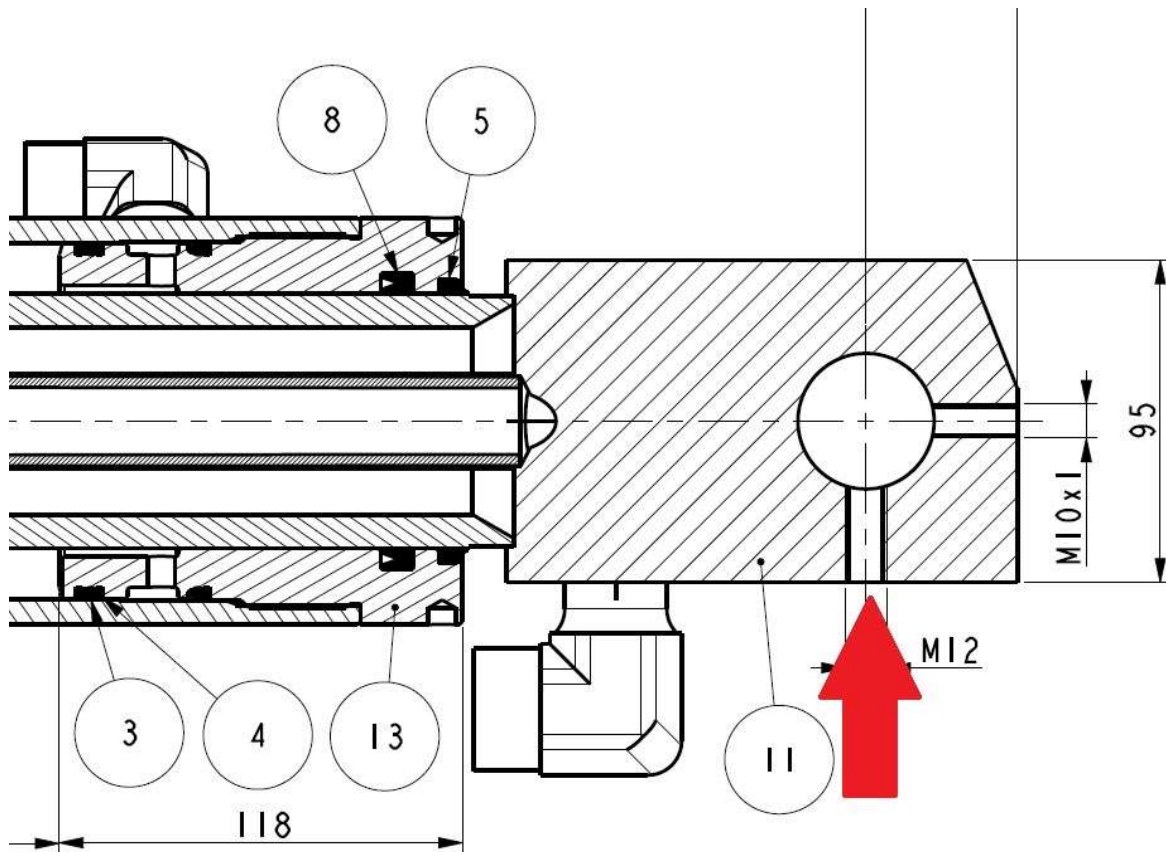

Technical Support  
Hiab Loader Cranes

**EFFER s.r.l.**  
 Società con socio unico soggetta  
 a Direzione e Coordinamento  
 di Cargotec Oyj  
 via IV Novembre, 12  
 40061 Minerbio, (BO) - Italia  
 Tel +390514181211  
 e-mail: contact@effer.com  
 effer.com

CCIAA di Bologna 452179  
 VAT/C.F./P.IVA/Reg. Imp. BO (IT) 01943080224  
 Fully Paid Up Capital € 1.600.000

# **Maintenance schedule**









## **Supplement to Chapter 9**

### **"Maintenance"**

#### **of the Operator's Manual**



























 **Maintenance schedule**

## LIST OF OPERATORS' PROFILES AVAILABLE FOR INSTALLATION, USE, MAINTENANCE AND INSPECTION OF THE CRANES

Pictogram	Tab. W
<b>A</b>	OWNER / EMPLOYER
<b>B</b> 	INSTALLER person / company responsible of the set up and installation of the crane on vehicle / unit / fixed base, in accordance with the instructions provided by Effer and according to the rules and laws in force in the country in which the equipment will be used.
<b>C</b> 	EFFER SERVICE CENTER person / company that received instructions training, resources by Effer to perform properly check interventions, testing, service and repairs on the crane. (*)
<b>QO</b> 	OPERATOR QUALIFIED TO CRANE USE: A person so designated by the employer who has appropriate training and adequate experience in the use of the crane.
<b>MQO</b> 	OPERATOR QUALIFIED TO BASIC CRANE SERVICE: A person so designated by the employer who has appropriate training and adequate experience in the use of the crane and in the simple maintenance of the crane.
<b>MQM</b> 	MECHANICAL OPERATOR QUALIFIED TO COMPLEX CRANE MAINTENANCE: Skilled person, like defined by standard ISO 12480-1-1997, trained to be authorized to carry out complex maintenance mechanical operations and, when provided, to update and to sign the inspection register. The personnel in charge of maintenance operations of Effer service centers covers this qualification.
<b>MQE</b> 	ELECTRICAL / ELECTRONIC QUALIFIED OPERATOR: Skilled person, like defined by standard ISO 12480-1997, trained to and authorized to perform maintenance operations, of electrical / electronic complexity and, when provided, to update and to sign the inspection register. The personnel in charge of maintenance operations of Effer service centers covers this qualification.
<b>IQ</b> 	QUALIFIED INSPECTOR (ISO 23814-2009 - Categories d): Experienced person with the necessary knowledge and well-known experience, so as to carry out such inspections to the crane. He/she should have practical skills that can facilitate the inspection procedures. Such capabilities can be derived by a combination of various experiences in the field. Moreover, he/she will have to update knowledge and skills as required by product innovation, and he/she will be free from any commercial, financial and other contractual interest that can influence his/her inspection job.
<b>IE</b> 	EXPERT ENGINEER (ISO 9927-1-2009 - TAB. A1): An engineer with experience in crane design, building, maintenance with adequate knowledge of regulations, standards and equipment necessary to carry out inspections. The experienced engineer must be also able to judge the safety status of the crane and to decide on measures that must be taken in order to ensure the correct safe operation; moreover, he/she must be free from any commercial, financial interest that could affect his investigative work.

(\*) The updated list of Effer service centers, can be found on the site [www.effer.com](http://www.effer.com)

 Maintenance schedule

<b>DAILY CHECKS (by the operator)</b>			
<b>Before each job</b>			
	<b>Element</b>	<b>Job</b>	
	Luminous/audible warning functions		
	Crane safety device efficiency		
	Winch safety device efficiency (when mounted)		
	Emergency push buttons efficiency		
	Stabiliser safety mechanical stop efficiency		
	Efficiency of distributor control leverst		
	Efficiency radio-remote control (when mounted)		
	Hydraulic oil level		
	Hook, hook safety, safety in general		
	Winch rope (when mounted)		
	Lifting accessories		
	Structural functionality and safety, wear, play, deformations, misalignments		
	Grub screws on rod head of extension cylinders		

**Note** *The work hours indicated in the tables are understood as time units for crane operation, the sum of the lift cycle times and the pause times according to the expected intermittent use (see previous chapters). In the event of heavier use in which the crane is operated / moved with brief pause periods and with heavier use than expected, the operation hours indicated in the tables must be decreased proportionally.*

























**Note** *The greasing intervals shown are referring to the use of high performing greases (see recommended greases).*

**Note** *Extraordinary maintenance jobs are to be carried out once a year at least, by authorised workshops.*





























## FIRST SERVICE

After initial 50 hours of work (it is advisable to have the first service done by an authorised workshop)





Element	Job	Operator profile
Macchina nel suo insieme (struttura e impianti)	  	
Oil Filter	  	
Winch screws (when mounted)	 	
Slewing tube, slewing ring, gear motor screws (depending on the model)	 	
Fixing kit screws	 	
Gear motor and winch oil level (when mounted)	 	
Tubi idraulici rigidi e flessibili, raccordi idraulici	 	
Structural functionality and safety, wear, play, deformations, misalignments		





















## ROUTINE MAINTENANCE

Every 20-30 hours of work or once a week.

Element	Job	Operator profile
Safety locking devices		
Column and rack/ slewing ring (depending on the model)	 	
Telescopic parts-crane extensions -stabilizers (if noises are heard or there is decreased performance)	 	
Pins		
Distributor control levers (when mounted)		
Hydraulic oil level		
Winch /pulleys (when mounted)		
Winch rope (when mounted)	 	
Hook and lifting accessories	  	
Stem surfaces cleaning of the exposed cylinders. Oil if the machine has not been running for more than 1 month.		
Structural functionality and safety, wear, play, deformations, misalignments		

 **Maintenance schedule**

ROUTINE MAINTENANCE		
Every 250 work hours or at least every 3 months		
Element	Job	Operator profile
Winch cable and chains (where applicable)(according to attachment VI LD 81/08		
Structural functionality and safety, wear, play, deformations, misalignments		

ROUTINE MAINTENANCE		
Every 500 work hours or every 6 months		
Element	Job	Operator profile
Screws/nuts/Seeger rings/pins		
Winch screws		
Rotation hydraulic cylinders shank screws/reducer screws		
Swivel ring screws	 	
Fixing kit screws		
Winch and reducers oil level		
Carpentry and plumbing inspection		
Luminous/audible/visual warnings		
Safety devices functionality control		
Electric cables and connections integrity control		

**◀ Maintenance schedule**

**EXTRAORDINARY MAINTENANCE \***

For operating instructions see the SERVICE MANUAL























Every 1000 hours of work or at least once a year



\* If, during an emergency situation, the crane has been subjected to overloads, or any by-passes, or the operator detects the need for an extraordinary maintenance operation in order to keep the equipment safe, immediately contact an authorized repair shop.

CRANE						
ITEMS TO CHECK	TYPE OF CHECK	TEST RESULTS			Lubrication replacement	Notes
		S	N	R		
Machine as a whole (structure and equipment)	- General visual inspections	<input type="checkbox"/>	<input type="checkbox"/>	<input type="checkbox"/>	<input type="checkbox"/>	
Signals, pictograms, posters, signs, notices	- Presence, readability, wear	<input type="checkbox"/>	<input type="checkbox"/>	<input type="checkbox"/>	<input type="checkbox"/>	
Counterframe	- Structural integrity, efficiency, structural functionality (*) - Wear, play, deformation, disalignment - Tie rods / screws / ring nuts tightening	<input type="checkbox"/>	<input type="checkbox"/>	<input type="checkbox"/>	<input type="checkbox"/>	
Stabilizers / feet / plates 	- Structural integrity, efficiency, structural functionality (*) - Wear, play, deformation - Tie rods / screws / ring nuts tightening - Lubrication - Adjustments	<input type="checkbox"/>	<input type="checkbox"/>	<input type="checkbox"/>	<input type="checkbox"/>	
Basement 	- Structural integrity, efficiency, structural functionality (*) - Wear, play, deformation - Tie rods / screws / ring nuts tightening - Lubrication - Adjustments	<input type="checkbox"/>	<input type="checkbox"/>	<input type="checkbox"/>	<input type="checkbox"/>	
Fifth wheel / gear / teeth 	- Structural integrity - Wear, play, - Screw tightening - Lubrication - Leaks	<input type="checkbox"/>	<input type="checkbox"/>	<input type="checkbox"/>	<input type="checkbox"/>	

## CRANE

ITEMS TO CHECK	TYPE OF CHECK	TEST RESULTS			Lubrication replacement	Notes
		S	N	R		
Column   	<ul style="list-style-type: none"> <li>- Structural integrity, efficiency, structural functionality (*)</li> <li>- Wear, play, deformation</li> <li>- Tie rods / screws / ring nuts tightening</li> <li>- Lubrication</li> <li>- Adjustments</li> </ul>	<input type="checkbox"/>	<input type="checkbox"/>	<input type="checkbox"/>	<input type="checkbox"/>	
1st Boom   	<ul style="list-style-type: none"> <li>- Structural integrity, efficiency, structural functionality (*)</li> <li>- Wear, play, deformation</li> <li>- Tie rods / screws / ring nuts tightening</li> <li>- Lubrication</li> </ul>	<input type="checkbox"/>	<input type="checkbox"/>	<input type="checkbox"/>	<input type="checkbox"/>	
Connecting rods   	<ul style="list-style-type: none"> <li>- Structural integrity, efficiency, structural functionality (*)</li> <li>- Wear, play, deformation</li> <li>- Tie rods / screws / ring nuts tightening</li> <li>- Lubrication</li> </ul>	<input type="checkbox"/>	<input type="checkbox"/>	<input type="checkbox"/>	<input type="checkbox"/>	
Pins and Bushings    	<ul style="list-style-type: none"> <li>- Structural integrity, efficiency, structural functionality (*)</li> <li>- Wear, play, deformation</li> <li>- Tie rods / screws / ring nuts tightening</li> <li>- Lubrication</li> </ul>	<input type="checkbox"/>	<input type="checkbox"/>	<input type="checkbox"/>	<input type="checkbox"/>	
2nd boom    	<ul style="list-style-type: none"> <li>- Structural integrity, efficiency, structural functionality (*)</li> <li>- Wear, play, deformation</li> <li>- Tie rods / screws / ring nuts tightening</li> <li>- Lubrication</li> <li>- Adjustments</li> </ul>	<input type="checkbox"/>	<input type="checkbox"/>	<input type="checkbox"/>	<input type="checkbox"/>	
Extensions booms / pads    	<ul style="list-style-type: none"> <li>- Structural integrity, efficiency, functionality</li> <li>- Wear, play, deformation</li> <li>- Tie rods / screws / ring nuts tightening</li> <li>- Lubrication</li> <li>- Grub screws on rod head of extension cylinder</li> </ul>	<input type="checkbox"/>	<input type="checkbox"/>	<input type="checkbox"/>	<input type="checkbox"/>	

(\*) Wear / play: eg. between metal parts, bushings, pads.































Structural integrity: verify the presence of cracks, deformation, breaks, pins functionality, cotter pins, See-ger, screws, etc..



















**Key:**

S: Yeah, ok, all operations were performed successfully according to crane instruction manual;

N: no, one or more operations were not performed successfully;









R: repaired, and recovery of the safety conditions.

JIB						
ITEMS TO CHECK	TYPE OF CHECK	TEST RESULTS			Lubrication replacement	Notes
		S	N	R		
Boom / coupling   	- Structural integrity, efficiency, structural functionality (*) - Wear, play, deformation, misalignement - Tie rods / screws / ring nuts tightening - Lubrication	<input type="checkbox"/>	<input type="checkbox"/>	<input type="checkbox"/>	<input type="checkbox"/>	
Connecting rods   	- Structural integrity, efficiency, structural functionality (*) - Wear, play, deformation, misalignement - Tie rods / screws / ring nuts tightening - Lubrication	<input type="checkbox"/>	<input type="checkbox"/>	<input type="checkbox"/>	<input type="checkbox"/>	
Pins and Bushings   	- Structural integrity, efficiency, structural functionality (*) - Wear, play, deformation, misalignement - Tie rods / screws / ring nuts tightening - Lubrication	<input type="checkbox"/>	<input type="checkbox"/>	<input type="checkbox"/>	<input type="checkbox"/>	
2nd boom / coupling    	- Structural integrity, efficiency, structural functionality (*) - Wear, play, deformation, misalignement - Tie rods / screws / ring nuts tightening - Lubrication - Adjustments	<input type="checkbox"/>	<input type="checkbox"/>	<input type="checkbox"/>	<input type="checkbox"/>	
Booms extensions / pads    	- Structural integrity, efficiency, structural functionality (*) - Wear, play, deformation, misalignement - Tie rods / screws / ring nuts tightening - Lubrication - Grub screws on rod head of extension cylinder	<input type="checkbox"/>	<input type="checkbox"/>	<input type="checkbox"/>	<input type="checkbox"/>	
ACCESSORIES						
ITEMS TO CHECK	TYPE OF CHECK	TEST RESULTS			Lubrication replacement	Notes
		S	N	R		
Winch / pulleys / cable / wire terminals    	- Structural integrity - Wear, play, deformation - Tie rods / screws / ring nuts tightening - Leaks - Lubrication	<input type="checkbox"/>	<input type="checkbox"/>	<input type="checkbox"/>	<input type="checkbox"/>	
Manual extensions	- Structural integrity - Wear, play, deformation - Marking integrity	<input type="checkbox"/>	<input type="checkbox"/>	<input type="checkbox"/>	<input type="checkbox"/>	
Lifting accessories (hooks, shackles, pins / cotter pins)     	- Structural integrity - Wear, play, deformation - Lubrication - Marking integrity	<input type="checkbox"/>	<input type="checkbox"/>	<input type="checkbox"/>	<input type="checkbox"/>	
Additional tools (buckets, rotors, baskets, etc.)     	- Structural integrity, efficiency, functionality - Wear, play, deformation - Tie rods / screws / ring nuts tightening	<input type="checkbox"/>	<input type="checkbox"/>	<input type="checkbox"/>	<input type="checkbox"/>	















HYDRAULIC SYSTEM						
ITEMS TO CHECK	TYPE OF CHECK	TEST RESULTS			Lubrication replacement	Notes
		S	N	R		
Hydraulic cylinders valves / hoses / bushes)   	<ul style="list-style-type: none"> <li>- Structural integrity, efficiency, functionality</li> <li>- Wear, play, deformation</li> <li>- Tie rods / screws / ring nuts tightening</li> <li>- Leaks</li> <li>- Functionality</li> <li>- Leaks</li> <li>- Leakage</li> <li>- Lubrication</li> </ul>	<input type="checkbox"/>	<input type="checkbox"/>	<input type="checkbox"/>	<input type="checkbox"/>	
Hydraulic motors   	<ul style="list-style-type: none"> <li>- Structural integrity, efficiency, functionality</li> <li>- Wear, play, deformation</li> <li>- Tie rods / screws / ring nuts tightening</li> <li>- Leaks</li> <li>- Leakage</li> <li>- Lubrication</li> </ul>	<input type="checkbox"/>	<input type="checkbox"/>	<input type="checkbox"/>	<input type="checkbox"/>	
PTO / pump   	<ul style="list-style-type: none"> <li>- Structural integrity, efficiency, functionality</li> <li>- Wear, play, deformation</li> <li>- Tie rods / screws / ring nuts tightening</li> <li>- Leaks</li> <li>- Leakage</li> <li>- Adjustments (check pressure and speed)</li> </ul>	<input type="checkbox"/>	<input type="checkbox"/>	<input type="checkbox"/>	<input type="checkbox"/>	
Valves Solenoid valves Controlbanks Hoses / pipes Delivery filters   	<ul style="list-style-type: none"> <li>- Structural integrity, efficiency, functionality</li> <li>- Wear, play, deformation</li> <li>- Tie rods / screws / ring nuts tightening</li> <li>- Functionality</li> <li>- Leaks</li> <li>- Leakage</li> <li>- Adjustments (check pressure and speed)</li> <li>- Sealing</li> <li>- Tamper Evident</li> <li>- Replacement of filter cartridges</li> <li>- Replacement of damaged flex hoses</li> </ul>	<input type="checkbox"/>	<input type="checkbox"/>	<input type="checkbox"/>	<input type="checkbox"/>	
Tank Oil / air filters   	<ul style="list-style-type: none"> <li>- Structural integrity, efficiency, functionality</li> <li>- Wear, play, deformation</li> <li>- Tie rods / screws / ring nuts tightening</li> <li>- Leaks</li> <li>- Oil replacement</li> <li>- Replacement of oil/air filter cartridges (**)</li> </ul>	<input type="checkbox"/>	<input type="checkbox"/>	<input type="checkbox"/>	<input type="checkbox"/>	
Flex hose reel   	<ul style="list-style-type: none"> <li>- Structural integrity, efficiency, functionality</li> <li>- Wear, play, deformation</li> <li>- Tie rods / screws / ring nuts tightening</li> <li>- Functionality</li> <li>- Leaks</li> <li>- Replacement of damaged flex hoses</li> <li>- Lubrication</li> </ul>	<input type="checkbox"/>	<input type="checkbox"/>	<input type="checkbox"/>	<input type="checkbox"/>	

(\*\*) Replace the air filter on the tank after 1000 working hours, in case of clogging signalled by the indicators (if any). To work in very dusty areas, replace every 500 hours











## ELECTRIC SYSTEM







ITEMS TO CHECK	TYPE OF CHECK	TEST RESULTS			Lubrication replacement	Notes
		S	N	R		
Emergency pump (if present)	   <ul style="list-style-type: none"> <li>- Structural integrity, efficiency, functionality</li> <li>- Wear, play, deformation</li> <li>- Tie rods / screws / ring nuts tightening</li> </ul>	<input type="checkbox"/>	<input type="checkbox"/>	<input type="checkbox"/>	<input type="checkbox"/>	
Electrical boxes Wiring Connectors	  <ul style="list-style-type: none"> <li>- Structural integrity, efficiency, functionality</li> <li>- Wear, play, deformation</li> <li>- Tie rods / screws / ring nuts tightening</li> <li>- Waterproof</li> <li>- Cleaning</li> <li>- Sealing</li> <li>- Tamper Evident</li> </ul>	<input type="checkbox"/>	<input type="checkbox"/>	<input type="checkbox"/>	<input type="checkbox"/>	
Sensors, electrical / electronic	  <ul style="list-style-type: none"> <li>- Structural integrity, efficiency, functionality</li> <li>- Wear, play, deformation</li> <li>- Tie rods / screws / ring nuts tightening</li> <li>- Calibration setting</li> <li>- Sealing</li> <li>- Tamper Evident</li> </ul>	<input type="checkbox"/>	<input type="checkbox"/>	<input type="checkbox"/>	<input type="checkbox"/>	
Audible and visual warnings	  <ul style="list-style-type: none"> <li>- Structural integrity, efficiency, functionality</li> <li>- Wear, play, deformation</li> <li>- Tie rods / screws / ring nuts tightening</li> </ul>	<input type="checkbox"/>	<input type="checkbox"/>	<input type="checkbox"/>	<input type="checkbox"/>	









## COMANDI

ITEMS TO CHECK	TYPE OF CHECK	TEST RESULTS			Lubrication replacement	Notes
		S	N	R		
Manual controls	    <ul style="list-style-type: none"> <li>- Structural integrity, efficiency, functionality</li> <li>- Wear, play, deformation</li> <li>- Tie rods / screws / ring nuts tightening</li> <li>- Lubrication</li> <li>- Sealing (limit switch)</li> <li>- Test</li> </ul>	<input type="checkbox"/>	<input type="checkbox"/>	<input type="checkbox"/>	<input type="checkbox"/>	
Emergency controls	    <ul style="list-style-type: none"> <li>- Structural integrity, efficiency, functionality</li> <li>- Wear, play, deformation</li> <li>- Tie rods / screws / ring nuts tightening</li> <li>- Lubrication</li> <li>- No Control levers fitted</li> <li>- Emergency levers fitted (when provided)</li> </ul>	<input type="checkbox"/>	<input type="checkbox"/>	<input type="checkbox"/>	<input type="checkbox"/>	
Seat / platform / entrances	    <ul style="list-style-type: none"> <li>- Structural integrity, efficiency, functionality</li> <li>- Wear, play, deformation</li> <li>- Tie rods / screws / ring nuts tightening</li> </ul>	<input type="checkbox"/>	<input type="checkbox"/>	<input type="checkbox"/>	<input type="checkbox"/>	
Remote control	  <ul style="list-style-type: none"> <li>- Structural integrity, efficiency, functionality</li> <li>- Wear, play, deformation</li> <li>- Tie rods / screws / ring nuts tightening</li> <li>- Waterproof</li> <li>- Cleaning</li> <li>- Test</li> </ul>	<input type="checkbox"/>	<input type="checkbox"/>	<input type="checkbox"/>	<input type="checkbox"/>	

## SAFETY DEVICES

ITEMS TO CHECK	TYPE OF CHECK	TEST RESULTS			Lubrication replacement	Notes
		S	N	R		
Parking brake / chocks (wheel lock wedges)	 <ul style="list-style-type: none"> <li>- Structural integrity, efficiency, functionality</li> <li>- Wear, play, deformation</li> <li>- Tie rods / screws / ring nuts tightening</li> </ul>	<input type="checkbox"/>	<input type="checkbox"/>	<input type="checkbox"/>	<input type="checkbox"/>	
Pins / safety pins	 <ul style="list-style-type: none"> <li>- Structural integrity, efficiency, functionality</li> <li>- Wear, play, deformation</li> <li>- Tie rods / screws / ring nuts tightening</li> </ul>	<input type="checkbox"/>	<input type="checkbox"/>	<input type="checkbox"/>	<input type="checkbox"/>	
Cylinders safety valves (general)	 <ul style="list-style-type: none"> <li>- Structural integrity, efficiency, functionality</li> <li>- Wear, play, deformation</li> <li>- Tie rods / screws / ring nuts tightening</li> </ul>	<input type="checkbox"/>	<input type="checkbox"/>	<input type="checkbox"/>	<input type="checkbox"/>	
Control systems (video cameras, mirrors, etc.)	 <ul style="list-style-type: none"> <li>- Structural integrity, efficiency, functionality</li> <li>- Wear, play, deformation</li> <li>- Tie rods / screws / ring nuts tightening</li> </ul>	<input type="checkbox"/>	<input type="checkbox"/>	<input type="checkbox"/>	<input type="checkbox"/>	
Transport safety devices (outriggers position, 1st boom, etc..)	 <ul style="list-style-type: none"> <li>- Structural integrity, efficiency, functionality</li> <li>- Wear, play, deformation</li> <li>- Tie rods / screws / ring nuts tightening</li> </ul>	<input type="checkbox"/>	<input type="checkbox"/>	<input type="checkbox"/>	<input type="checkbox"/>	
Controls and protections for interlocks	 <ul style="list-style-type: none"> <li>- Structural integrity, efficiency, functionality</li> <li>- Wear, play, deformation</li> <li>- Tie rods / screws / ring nuts tightening</li> </ul>	<input type="checkbox"/>	<input type="checkbox"/>	<input type="checkbox"/>	<input type="checkbox"/>	
Indicators of clogged oil / air filters	 <ul style="list-style-type: none"> <li>- Structural integrity, efficiency, functionality</li> <li>- Wear, play, deformation</li> <li>- Tie rods / screws / ring nuts tightening</li> </ul>	<input type="checkbox"/>	<input type="checkbox"/>	<input type="checkbox"/>	<input type="checkbox"/>	
Luminous acoustic signals (general)	 <ul style="list-style-type: none"> <li>- Structural integrity, efficiency, functionality</li> <li>- Wear, play, deformation</li> <li>- Tie rods / screws / ring nuts tightening</li> </ul>	<input type="checkbox"/>	<input type="checkbox"/>	<input type="checkbox"/>	<input type="checkbox"/>	
Stop button and / or emergency	 <ul style="list-style-type: none"> <li>- Structural integrity, efficiency, functionality</li> <li>- Wear, play, deformation</li> <li>- Tie rods / screws / ring nuts tightening</li> </ul>	<input type="checkbox"/>	<input type="checkbox"/>	<input type="checkbox"/>	<input type="checkbox"/>	
Tamper-proof devices, (seals, mechanical seals, adhesives, paint, electronic recordings)	 <ul style="list-style-type: none"> <li>- Structural integrity, efficiency, functionality</li> <li>- Wear, play, deformation</li> </ul>	<input type="checkbox"/>	<input type="checkbox"/>	<input type="checkbox"/>	<input type="checkbox"/>	

Crane moment limiter		Operational test	<input type="checkbox"/>	<input type="checkbox"/>	<input type="checkbox"/>	<input type="checkbox"/>	
Crane position limiter		Operational test	<input type="checkbox"/>	<input type="checkbox"/>	<input type="checkbox"/>	<input type="checkbox"/>	
Crane load indicator		Operational test	<input type="checkbox"/>	<input type="checkbox"/>	<input type="checkbox"/>	<input type="checkbox"/>	
Crane stability control device		Operational test	<input type="checkbox"/>	<input type="checkbox"/>	<input type="checkbox"/>	<input type="checkbox"/>	
Winch load limiters		Operational test	<input type="checkbox"/>	<input type="checkbox"/>	<input type="checkbox"/>	<input type="checkbox"/>	
Winch limit up		Operational test	<input type="checkbox"/>	<input type="checkbox"/>	<input type="checkbox"/>	<input type="checkbox"/>	
Winch limit down		Operational test	<input type="checkbox"/>	<input type="checkbox"/>	<input type="checkbox"/>	<input type="checkbox"/>	
Basket devices			<input type="checkbox"/>	<input type="checkbox"/>	<input type="checkbox"/>	<input type="checkbox"/>	

ITEMS TO CHECK	TYPE OF CHECK	TEST RESULTS			Lubrication replacement	Notes
		S	N	R		
General lubrication   	- According to user manual	<input type="checkbox"/>	<input type="checkbox"/>	<input type="checkbox"/>	<input type="checkbox"/>	
Operation testing on vacuum 	- Test	<input type="checkbox"/>	<input type="checkbox"/>	<input type="checkbox"/>	<input type="checkbox"/>	
Operation tests with load diagram 	- Test	<input type="checkbox"/>	<input type="checkbox"/>	<input type="checkbox"/>	<input type="checkbox"/>	
Checking the documentation (operator's manual, control register) 	- Accuracy of the documentation	<input type="checkbox"/>	<input type="checkbox"/>	<input type="checkbox"/>	<input type="checkbox"/>	
Checking the conditions of use of the crane (condition - SWP) 	- Analysis by calculating residual SWP (CL%)	<input type="checkbox"/>	<input type="checkbox"/>	<input type="checkbox"/>	<input type="checkbox"/>	
Place Date 	Stamp and signature	<input type="checkbox"/>	<input type="checkbox"/>	<input type="checkbox"/>	<input type="checkbox"/>	