



# HYUNDAI Technical Service Bulletin

GROUP <b>CAMPAIGN</b>	NUMBER <b>22-01-016H-1</b>
DATE <b>MARCH, 2022</b>	MODEL(S) <b>PALISADE (LX2)</b>

**SUBJECT:** FRONT DOOR LOWER GARNISH REPAIR PROCEDURES  
(SERVICE CAMPAIGN 975)

This TSB supersedes 22-01-016H by adding Abyss Black (A2B) to the paint touch up pen list.

**\* IMPORTANT**

**\*\*\* Dealer Stock and Retail Vehicles \*\*\***

Dealers must perform this Service Campaign on all affected vehicles prior to customer retail delivery and whenever an affected vehicle is in the shop for any maintenance or repair.

When a vehicle arrives at the Service Department, access the "Vehicle Information" screen via WEBDCS to identify open Campaigns.

**Description:** Certain 2020 – 2022MY Palisade (LX2) vehicles may have been produced with a rough edge on the front door lower garnishes during manufacturing. This bulletin describes the procedure to repair the condition.



**Applicable Vehicles:** Certain 2020 – 2022MY Palisade (LX2) vehicles built between 4/10/2019 – 12/29/2021.

**Parts Information:**

PART NAME	EXTERIOR COLOR NAME	EXTERIOR COLOR CODE	PART NUMBER
Paint Touch Up Pen	Becketts Black	RB5	00F05-AU000-RB5
	Hyper White	WC9	00F05-AU000-WC9
	Lagoon Silver	S7S	00F05-AU000-S7S
	Steel Graphite	P7V	00F05-AU000-P7V
	Sierra Burgundy	W7B	00F05-AU000-W7B
	Moonlight Cloud	UB7	00F05-AU000-UB7
	Rainforest	R2F	00F05-AU000-R2F
	Typhoon Silver	T2X	00F05-AU000-T2X
	Abyss Black	A2B	00F05-AU000-A2B

**NOTE 1:** Paint touch up pens are only required for Limited and Calligraphy trims, which have painted body colored lower garnishes.

**NOTE 2:** One paint touch up pen can be used for 5 vehicles.

Circulate To: General Manager, Service Manager, Parts Manager, Warranty Manager, Service Advisors, Technicians, Body Shop Manager, Fleet Repair

**Warranty Information:**

MODEL	OP CODE	OPERATION	OP TIME	CAUSAL PART	NATURE CODE	CAUSE CODE
Palisade (LX2)	10D219R0	FRONT DOOR LOWER GARNISH EDGE PART CUTTING AND GRINDING	0.3 M/H	82250-S8000	A36	ZZ2
	10D219R2	FRONT DOOR LOWER GARNISH EDGE PART CUTTING AND GRINDING - PAINT TOUCH UP				

**NOTE 1:** Submit claim on Campaign Claim Entry Screen,

**NOTE 2:** If a part that is not covered by this Service Campaign is in need of replacement while performing this Service Campaign, and the affected part is still under warranty, please submit a separate claim using the same repair order. If the part is out of warranty, submit a prior approval request for goodwill consideration prior to performing the work.

**NOTE 3:** Use of touch up paint in the amount of \$4.00 will be reimbursed in sublet under labor operation 10D219R2.

**Service Procedure:**

1. Open the vehicle's front door.

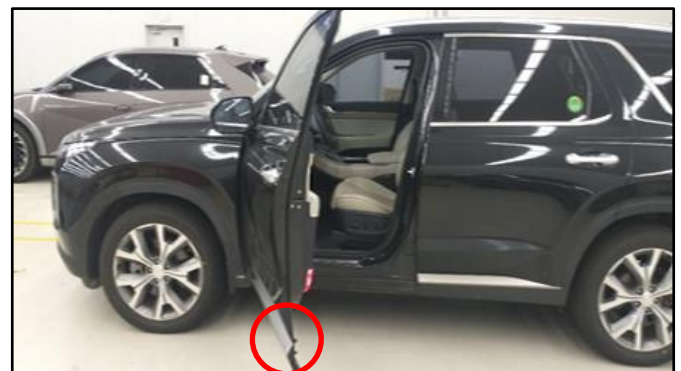

2. Inspect the lower corner where the door garnish and door garnish bracket (A) meet.

**NOTICE**

The part to be corrected is the door garnish, not the door garnish bracket.

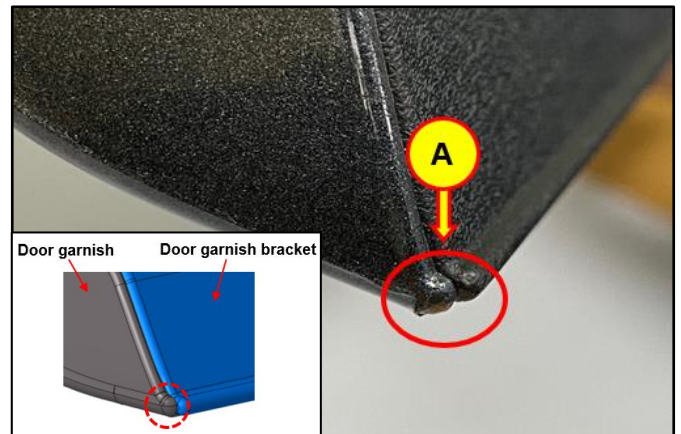

3. Using a razor blade, cut the door garnish (B) along the lower garnish line.

**NOTICE**

Cut approximately 1/16 in (2 mm) from the garnish end.

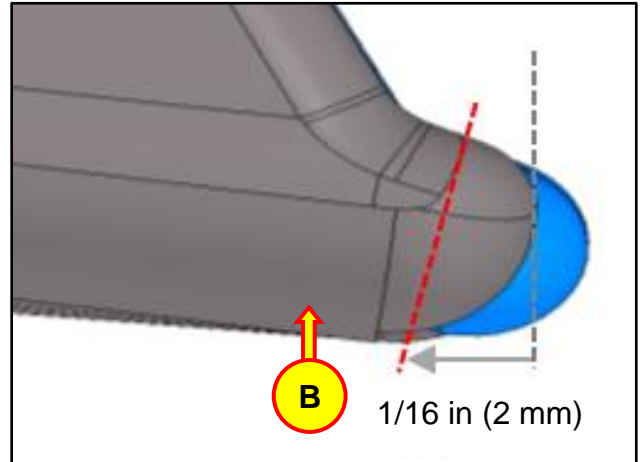

**NOTICE**

Do not cut too deep on the door garnish. Damage to the door garnish bracket may occur.



**NOTICE**

Inspect the area with your fingertips after cutting to be sure there are no sharp edges.

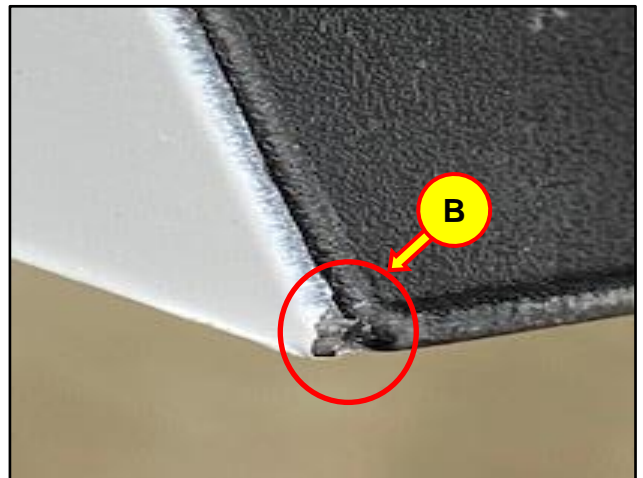

4. Use 600 grit sandpaper to smooth out the door garnish area that was cut.



5. Inspect the area with your fingertips to ensure there are no sharp edges after sanding.



6. If necessary, apply touch up paint to the lower garnish with a touch up paint pen.

**NOTICE**

Paint touch up is not necessary for non-painted garnishes. Painted garnishes are applied only on Limited and Calligraphy trims and are body colored.



7. Use a heat gun to apply heat in a sweeping motion for approximately 1-2 minutes to assist with drying the touch up paint.

**NOTICE**

**Do not apply heat too close to the garnish as it may cause damage.**



8. The service procedure is complete.