

March 30, 2022

Version 1

Warranty Extension: Engine Does Not Auto Restart After Entering Auto Idle Stop

AFFECTED VEHICLES

Year	Model	Trim Level	VIN Range
2015–20	TLX	V6 (SH-AWD)	Check the iN VIN status for eligibility

BACKGROUND

Under certain circumstances, after coming to a stop and engaging idle stop the vehicle may not restart automatically due to excessive cylinder pressure and/or low cranking torque. Typically, the client can immediately restart the vehicle by selecting Park and pressing the ENGINE START/STOP button.

Acura is extending the warranty coverage for valve adjustment and starter replacement related to this condition to 10 years from the original date of purchase with no mileage limitation.

CLIENT NOTIFICATION

Owners of the affected vehicles will be sent a notification of this campaign.

Do an iN VIN status inquiry to make sure the vehicle is shown as eligible.

CORRECTIVE ACTION

Replace the starter assembly, stator relays and adjust the valves.

PARTS INFORMATION

Part Name	Part Number	Quantity
Starter Motor Assy	31200-5J2-A53	1
Relay Assy, Power	39794-T5A-J01	2
Bolt, Flange	90051-5J4-000	1
Gasket Throttle Body	16176-RYE-A10	1
Gasket, Intake Manifold Cover	17112-5G0-A01	1
Gasket, Intake Manifold	17105-R9P-A01	1

NOTE: If 22-008 *Product Update: 2015-20 TLX PGM-FI Idle Stop Software Update* is applicable to the VIN, the PGM-FI software must be updated first before the warranty extension applies. Any Warranty Extension claims submitted prior to an approved Product Update, will be debited.

CLIENT INFORMATION: The information in this bulletin is intended for use only by skilled technicians who have the proper tools, equipment, and training to correctly and safely maintain your vehicle. These procedures should not be attempted by “do-it-yourselfers,” and you should not assume this bulletin applies to your vehicle, or that your vehicle has the condition described. To determine whether this information applies, contact an authorized Acura automobile dealer.

REQUIRED MATERIALS

Part Name	Part Number	Quantity
Hondabond (one tube repairs 4 vehicles)	08718-0004	1

TOOL INFORMATION

Tool Name	Tool Number	Quantity
Relay Puller	07AAC-000A2A1	1

WARRANTY CLAIM INFORMATION

Operation Number	Description	Flat Rate Time	Defect Code	Symptom Code	Template ID	Failed Part Number
1181FF	Replace the Starter, Starter Relays and Adjust Valves	2.8 hr	6T600	GC900	B22009A	31200-5J2-A52

Skill Level: Repair Technician

INSPECTION PROCEDURE

Does 22-008 *Product Update: 2015-20 TLX PGM-FI Idle Stop Software Update* apply to the VIN?

Yes – Confirm 22-008 *Product Update: 2015-20 TLX PGM-FI Idle Stop Software Update* is closed by checking VIN inquiry.

- If closed, verify the symptom, if present, proceed to the repair procedure.
- If open, perform 22-008 *Product Update: 2015-20 TLX PGM-FI Idle Stop Software Update*. **Repair is complete.**

No – Verify the symptom, if present, proceed to the repair procedure.

REPAIR PROCEDURE

Starter Removal and installation.

1. Disconnect the 12 volt battery.
2. Remove the 12 volt battery setting plate and the 12 volt battery.

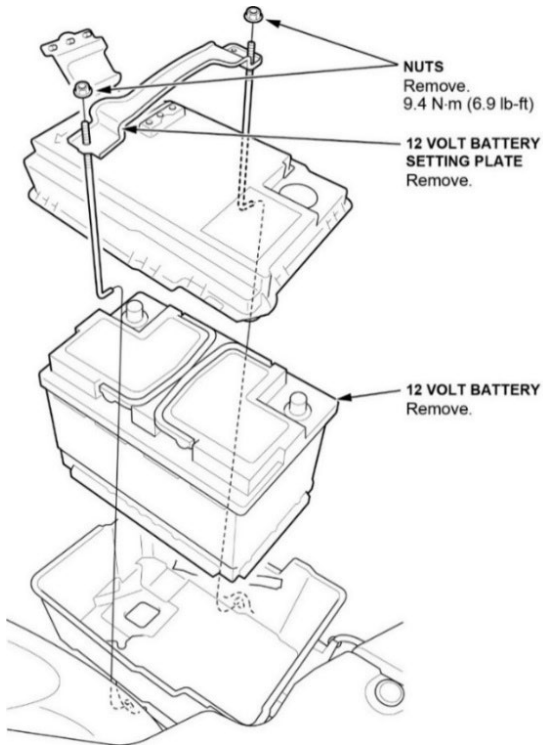

3. Disconnect the connector from the air cleaner, then remove the harness clamps and remove the air cleaner assembly.

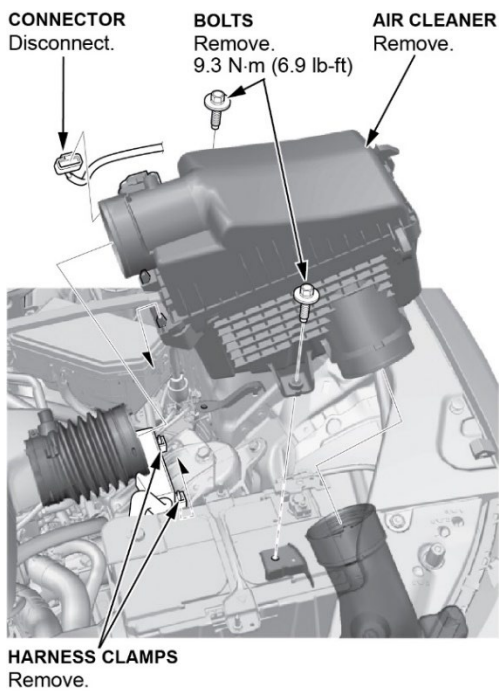

4. Remove the harness holder from the starter.

5. Disconnect the positive starter cable and the connector, then remove the starter.

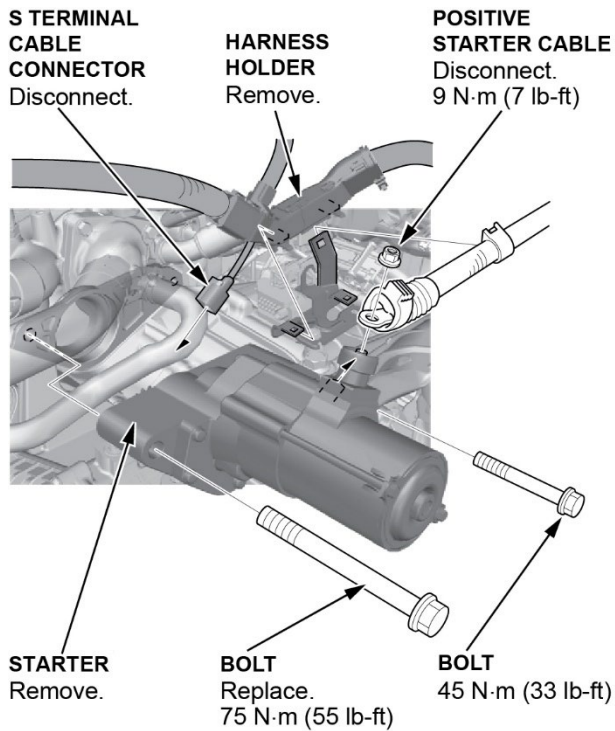

6. Reinstall the parts in the reverse order of removal.
7. Replace start cut relay 1 and starter cut relay 2.
8. Connect the HDS to the DLC.
9. Turn the vehicle to the ON mode.
10. Make sure the HDS communicates with the vehicle, then select **Idle Stop Starter Counter Clear** in the **ADJUSTMENT MENU** with the HDS.

Valve Clearance Adjustment

1. Disconnecting the breather pipe and remove the intake air duct.

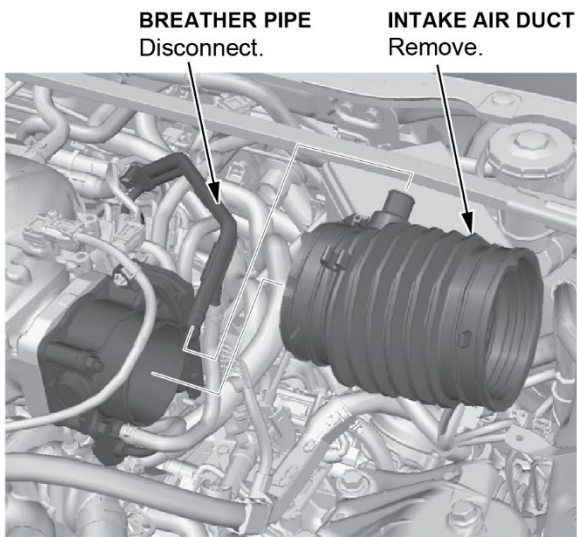

2. Disconnect the connectors and EVAP purge hose. Remove the throttle body without disconnecting the water bypass hoses.

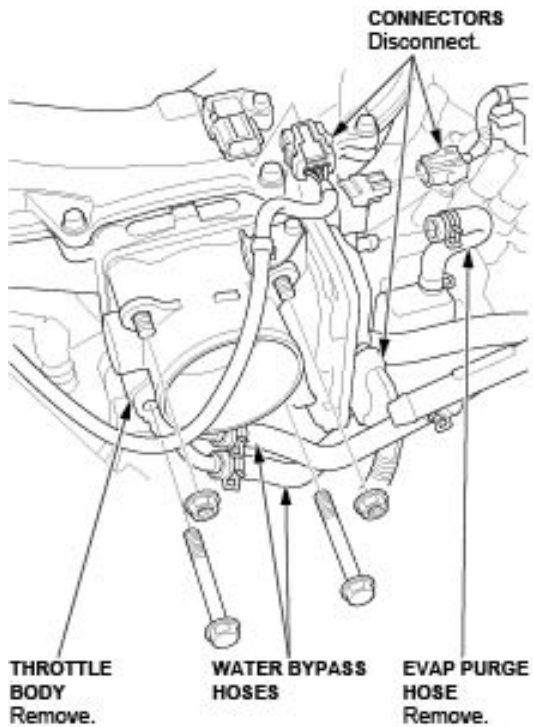

3. Disconnect the PCV hose and the brake booster vacuum hose.

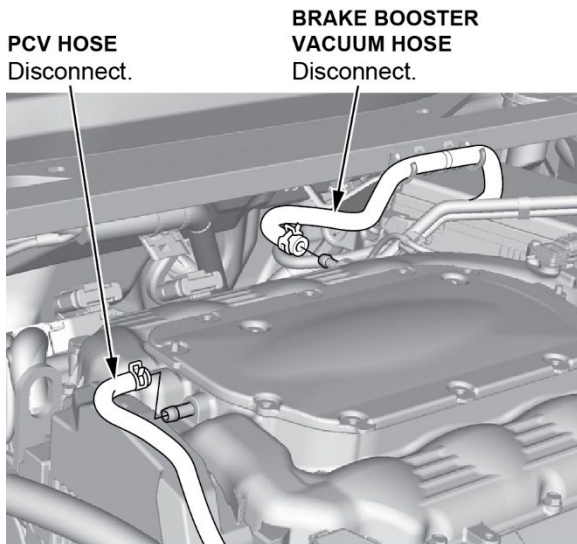

4. Remove the upper cover mounting bolts and nuts sequentially in three steps. Remove the upper cover.

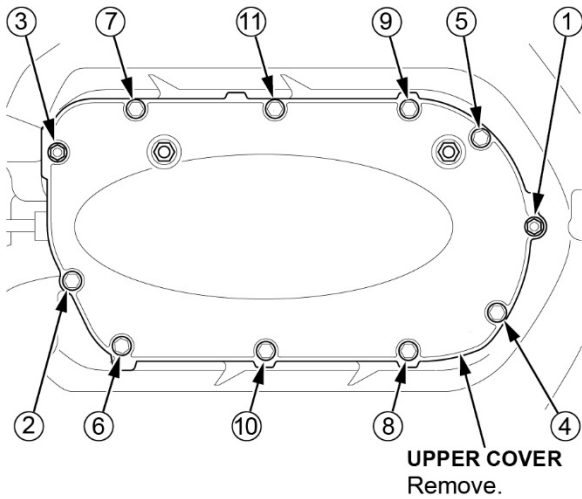

5. Remove the intake manifold mounting bolts and nuts sequentially in three steps. Remove the intake manifold.

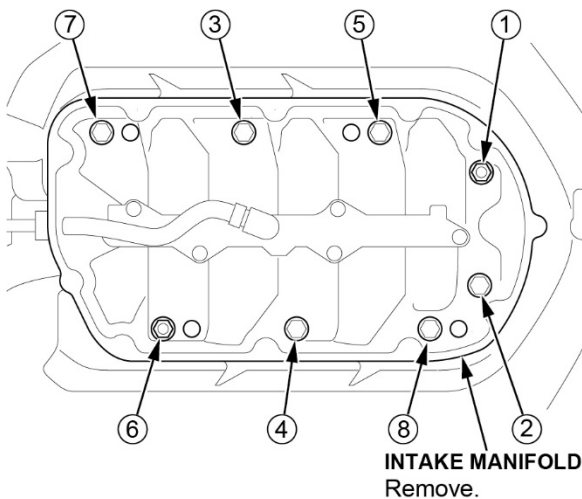

6. Remove the ignition coils, positive alternator cable, and harness holders on both cylinder heads.

7. Remove cylinder head covers.

NOTE: Connect the HDS to the DLC and monitor ECT SENSOR 1. When the engine has cooled down and the coolant temperature is less than 100°F (38°C), adjust the valve clearance.

8. Set the No. 1 piston at top dead center (TDC). Align the pointer on the front upper cover with the No. 1 piston TDC mark on the front camshaft pulley.

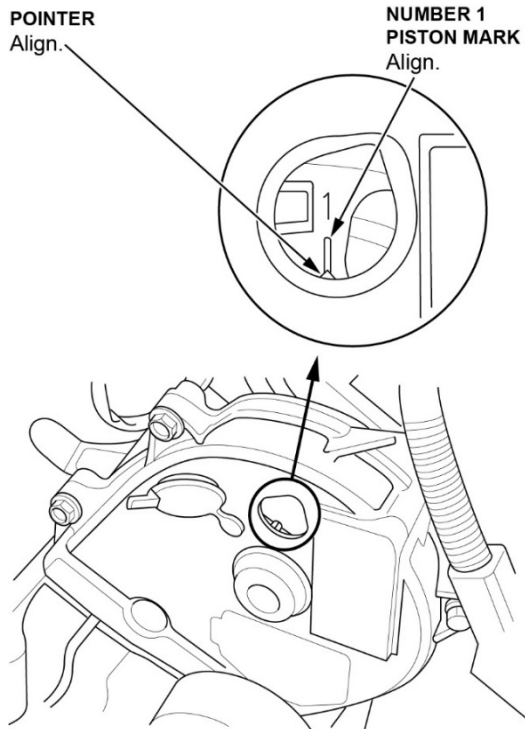

9. Select the correct feeler gauge for the valve clearance you are going to check.

Valve Clearance Spec:

- Intake: 0.20–0.24 mm (0.008–0.009 in)
- Exhaust: 0.28–0.32 mm (0.011–0.012 in)

For this repair, you'll set the valve clearance to these specs:

- **Intake .22 mm**
- **Exhaust .30 mm**

REAR

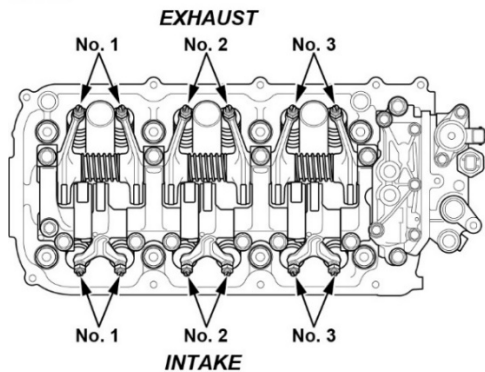

FRONT

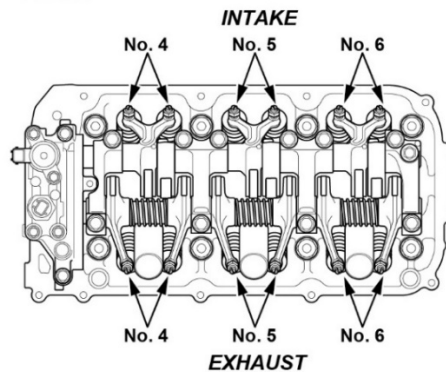

10. Insert the feeler gauge between the adjusting screw and the end of the valve stem on the No. 1 cylinder and slide it back and forth; you should feel a slight amount of drag.

INTAKE

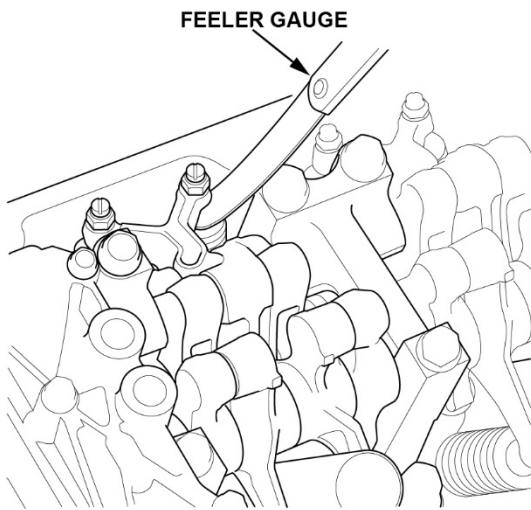

EXHAUST

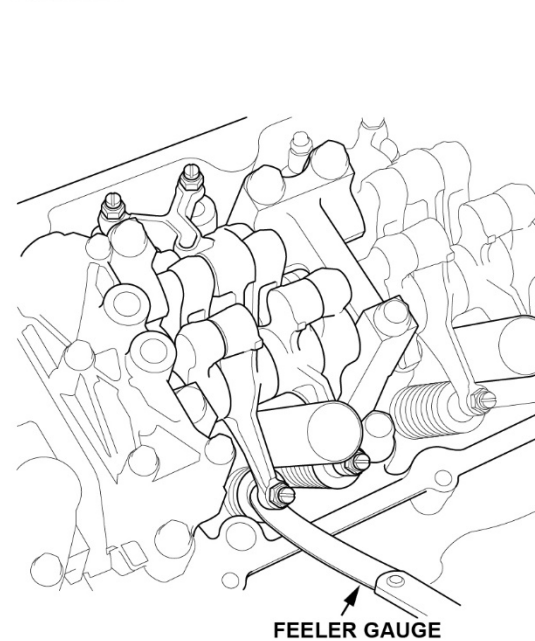

11. If you feel too much or too little drag, loosen the locknut, then turn the adjusting screw until the drag on the feeler gauge is correct.
12. While holding the adjusting screw with the screwdriver, tighten the locknut, then recheck the clearance. Repeat the adjustment, if necessary.

Specified Torque

Intake: 20 N·m (15 lbf·ft)

Exhaust: 20 N·m (15 lbf·ft)

Apply new engine oil to the nut threads.

INTAKE

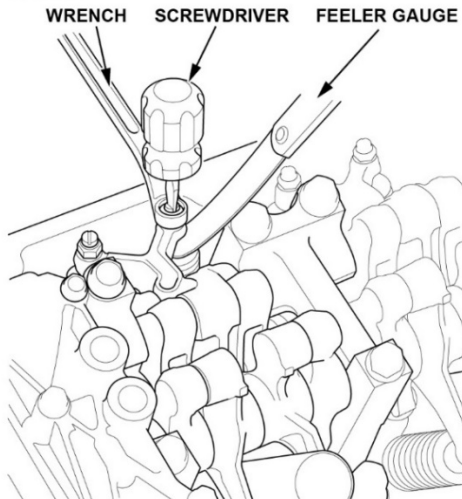

EXHAUST

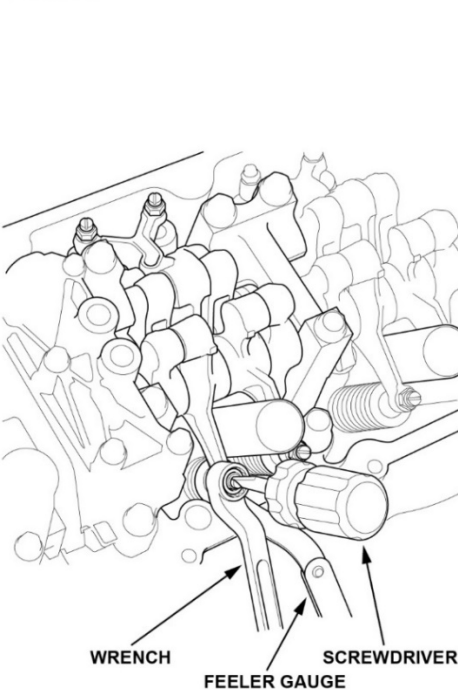

13. Rotate the crankshaft clockwise. Align the pointer on the front upper cover with the No. 4 piston TDC mark on the front camshaft pulley.
14. Check, and if necessary, adjust the valve clearance on the No. 4 cylinder.

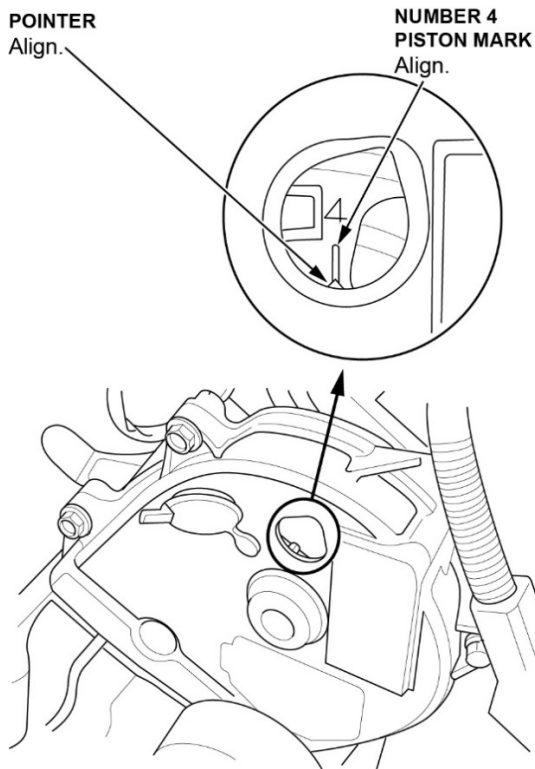

15. Rotate the crankshaft clockwise. Align the pointer on the front upper cover with the No. 2 piston TDC mark on the front camshaft pulley.
16. Check, and if necessary, adjust the valve clearance on the No. 2 cylinder.

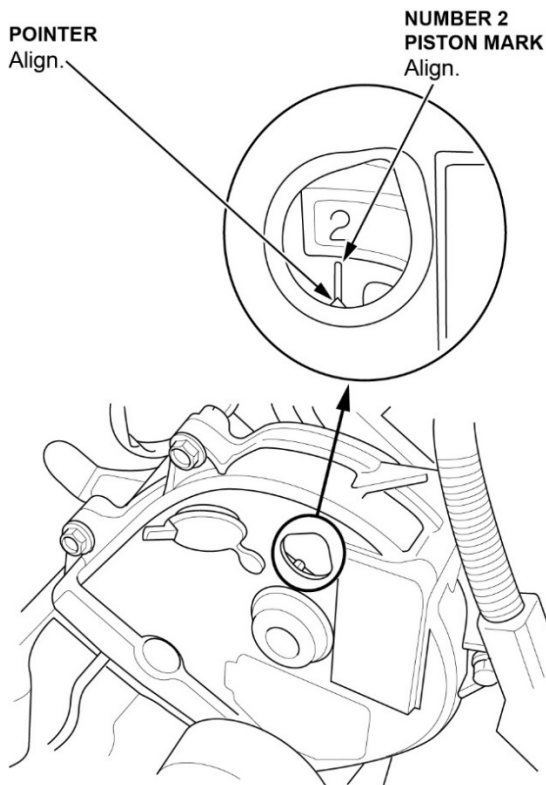

17. Rotate the crankshaft clockwise. Align the pointer on the front upper cover with the No. 5 piston TDC mark on the front camshaft pulley.
18. Check, and if necessary, adjust the valve clearance on the No. 5 cylinder.

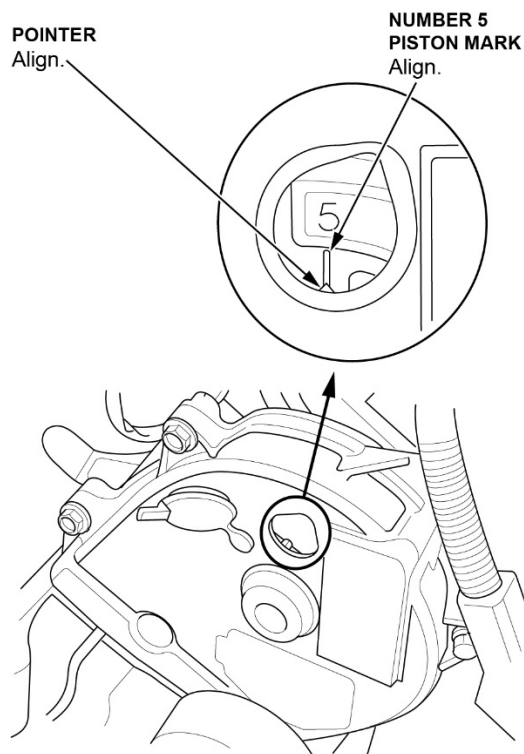

19. Rotate the crankshaft clockwise. Align the pointer on the front upper cover with the No. 3 piston TDC mark on the front camshaft pulley.
20. Check, and if necessary, adjust the valve clearance on the No. 3 cylinder.

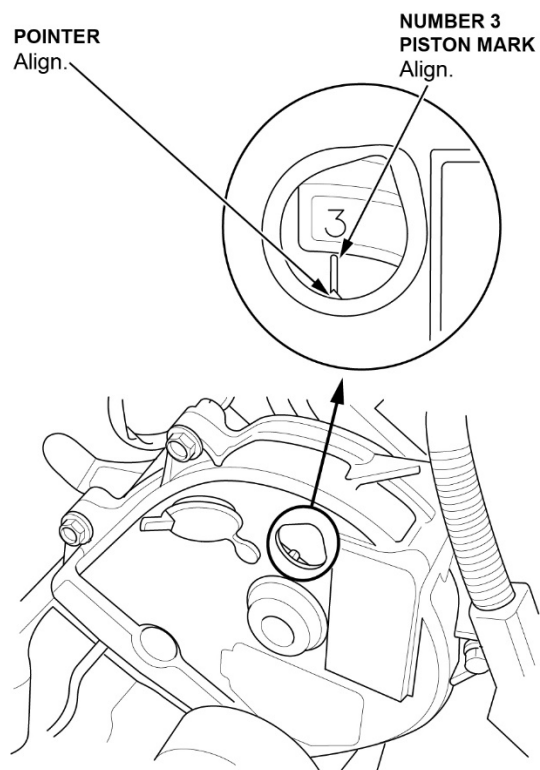

21. Rotate the crankshaft clockwise. Align the pointer on the front upper cover with the No. 6 piston TDC mark on the front camshaft pulley.
22. Check, and if necessary, adjust the valve clearance on the No. 6 cylinder.

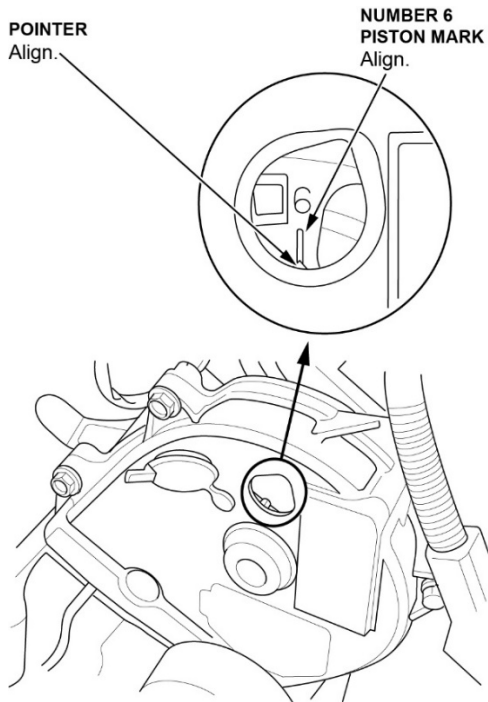

23. Check the spark plug seals for damage. If any seals are damaged, replace it.
24. Thoroughly clean the head cover gasket and the groove of the cylinder head cover.
NOTE: Check and if necessary, replace the head cover gasket.
25. Install the head cover gasket in the groove of the cylinder head cover. Make sure the head cover gasket is seated securely.
26. Apply liquid gasket to the front and rear rocker arm oil control valve mating surfaces.

FRONT ROCKER ARM OIL CONTROL VALVE

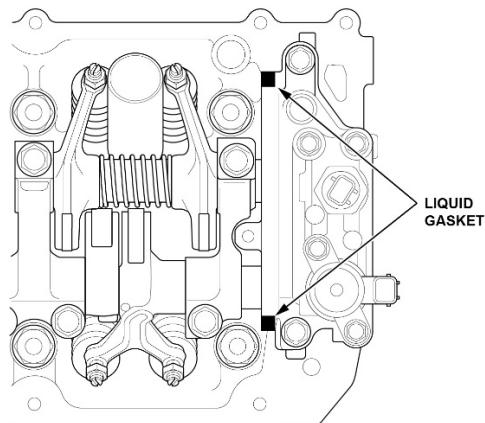

REAR ROCKER ARM OIL CONTROL VALVE

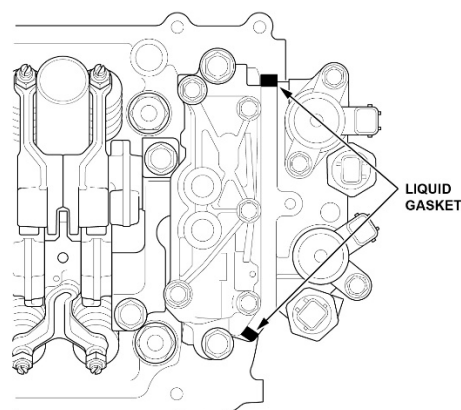

27. Set the spark plug seals on the spark plug tubes and install the front and rear cylinder head cover.
28. Inspect the spark plug seals for damage.
29. Tighten the bolts in three steps, in the final step torque the bolts, in sequence, **12 N·m (9 lbf·ft)**.
30. Reinstall the remaining parts in the reverse order.

END